



10N50

Preliminary

Power MOSFET

10 Amps, 500 Volts N-CHANNEL POWER MOSFET

DESCRIPTION

The UTC **10N50** is an N-channel mode power MOSFET using UTC's advanced technology to provide customers with planar stripe and DMOS technology. This technology allows a minimum on-state resistance and superior switching performance. It also can withstand high energy pulse in the avalanche and commutation mode.

The UTC **10N50** is generally applied in high efficiency switch mode power supplies, active power factor correction and electronic lamp ballasts based on half bridge topology.

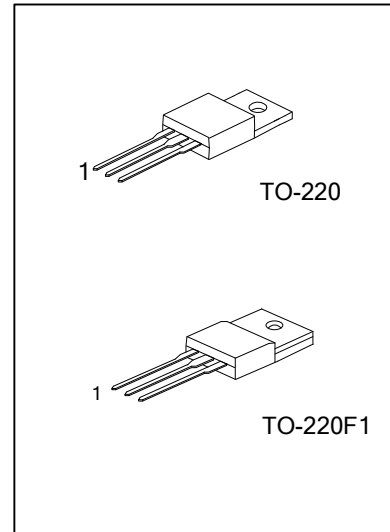

FEATURES

- * 10A, 500V, $R_{DS(ON)}=0.61\Omega @ V_{GS}=10V$
- * High Switching Speed
- * 100% Avalanche Tested

SYMBOL

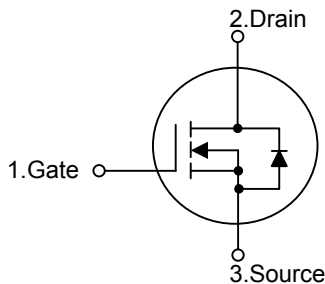

ORDERING INFORMATION

Ordering Number		Package	Pin Assignment			Packing
Lead Free	Halogen Free		1	2	3	
10N50L-TA3-T	10N50G-TA3-T	TO-220	G	D	S	Tube
10N50L-TF1-T	10N50G-TF1-T	TO-220F1	G	D	S	Tube

Note: Pin Assignment: G: Gate D: Drain S: Source

10N50L-TA3-T	(1)Packing Type	(1) T: Tube
	(2)Package Type	(2) TA3: TO-220 ,TF1: TO-220F1
	(3)Lead Free	(3) G: Halogen Free, L: Lead Free

www.DataSheet4U.com

■ ABSOLUTE MAXIMUM RATINGS ($T_C=25^\circ\text{C}$, unless otherwise specified)

PARAMETER		SYMBOL	RATINGS	UNIT
Drain-Source Voltage		V_{DSS}	500	V
Gate-Source Voltage		V_{GSS}	± 30	V
Drain Current	Continuous ($T_C=25^\circ\text{C}$)	I_D	10 (Note 2)	A
	Pulsed (Note 3)	I_{DM}	40 (Note 2)	A
Avalanche Current (Note 3)		I_{AR}	10	A
Avalanche Energy	Single Pulsed (Note 4)	E_{AS}	388	mJ
	Repetitive (Note 5)	E_{AR}	14.3	mJ
Peak Diode Recovery dv/dt (Note 5)		dv/dt	4.5	V/ns
Power Dissipation	$T_C=25^\circ\text{C}$	TO-220	143	W
		TO-220F1	48	
	Derate above 25°C	TO-220	1.14	$\text{W}/^\circ\text{C}$
		TO-220F1	0.38	
Junction Temperature		T_J	+150	$^\circ\text{C}$
Storage Temperature		T_{STG}	-55~+150	$^\circ\text{C}$

Note: 1. Absolute maximum ratings are those values beyond which the device could be permanently damaged.

Absolute maximum ratings are stress ratings only and functional device operation is not implied.

2. Drain current limited by maximum junction temperature
3. Repetitive Rating: Pulse width limited by maximum junction temperature
4. $L = 7\text{mH}$, $I_{AS} = 10\text{A}$, $V_{DD} = 50\text{V}$, $R_G = 25\Omega$, Starting $T_J = 25^\circ\text{C}$
5. $I_{SD} \leq 10\text{A}$, $di/dt \leq 200\text{A}/\mu\text{s}$, $V_{DD} \leq BV_{DSS}$, Starting $T_J = 25^\circ\text{C}$

■ THERMAL DATA

PARAMETER		SYMBOL	RATINGS	UNIT
Junction to Ambient	TO-220	θ_{JA}	62.5	$^\circ\text{C}/\text{W}$
	TO-220F1		62.5	
Junction to Case	TO-220	θ_{JC}	0.87	$^\circ\text{C}/\text{W}$
	TO-220F1		2.58	

■ ELECTRICAL CHARACTERISTICS ($T_c=25^\circ\text{C}$, unless otherwise specified)

PARAMETER	SYMBOL	TEST CONDITIONS	MIN	TYP	MAX	UNIT	
OFF CHARACTERISTICS							
Drain-Source Breakdown Voltage	BV_{DSS}	$I_D=250\mu\text{A}$, $V_{GS}=0\text{V}$	500			V	
Drain-Source Leakage Current	I_{DSS}	$V_{DS}=500\text{V}$, $V_{GS}=0\text{V}$			1	μA	
Gate- Source Leakage Current	Forward	I_{GSS}			+100	nA	
	Reverse				-100	nA	
ON CHARACTERISTICS							
Gate Threshold Voltage	$V_{GS(TH)}$	$V_{DS}=V_{GS}$, $I_D=250\mu\text{A}$	2.0		4.0	V	
Static Drain-Source On-State Resistance	$R_{DS(ON)}$	$V_{GS}=10\text{V}$, $I_D=5\text{A}$		0.5	0.61	Ω	
DYNAMIC PARAMETERS							
Input Capacitance	C_{ISS}	$V_{GS}=0\text{V}$, $V_{DS}=25\text{V}$, $f=1.0\text{MHz}$		1610	2096	pF	
Output Capacitance	C_{OSS}				177	230	pF
Reverse Transfer Capacitance	C_{RSS}				16	24	pF
SWITCHING PARAMETERS							
Total Gate Charge	Q_G	$V_{GS}=10\text{V}$, $V_{DS}=400\text{V}$, $I_D=10\text{A}$ (Note 6, 7)		43	56	nC	
Gate to Source Charge	Q_{GS}			7.5		nC	
Gate to Drain Charge	Q_{GD}			18.5		nC	
Turn-ON Delay Time	$t_{D(ON)}$	$V_{DD}=250\text{V}$, $I_D=10\text{A}$, $R_G=25\Omega$ (Note 6, 7)		29	67	ns	
Rise Time	t_R			80	170	ns	
Turn-OFF Delay Time	$t_{D(OFF)}$			141	290	ns	
Fall-Time	t_F			80	165	ns	
SOURCE- DRAIN DIODE RATINGS AND CHARACTERISTICS							
Maximum Body-Diode Continuous Current	I_S				10	A	
Maximum Body-Diode Pulsed Current	I_{SM}				40	A	
Drain-Source Diode Forward Voltage	V_{SD}	$I_S=10\text{A}$, $V_{GS}=0\text{V}$			1.4	V	
Body Diode Reverse Recovery Time	t_{RR}	$I_S=10\text{A}$, $V_{GS}=0\text{V}$, $di_F/dt=100\text{A}/\mu\text{s}$ (Note 6)		50		ns	
Body Diode Reverse Recovery Charge	Q_{RR}				0.1		μC

Notes: 6. Pulse Test: Pulse width $\leq 300\mu\text{s}$, Duty cycle $\leq 2\%$

7. Essentially independent of operating temperature

■ TEST CIRCUITS AND WAVEFORMS

Gate Charge Test Circuit

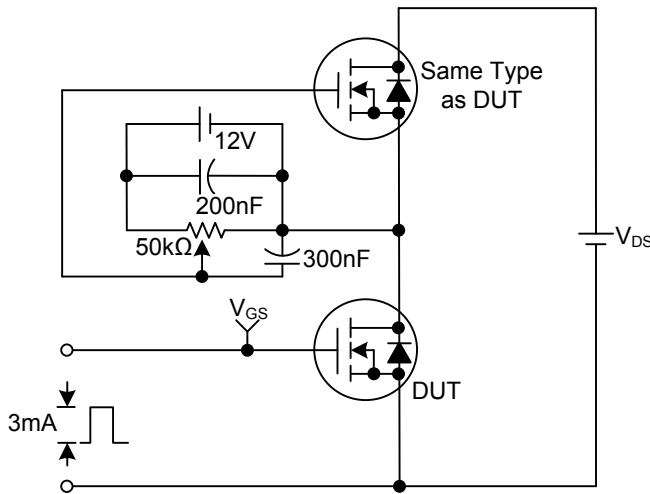

Gate Charge Waveforms

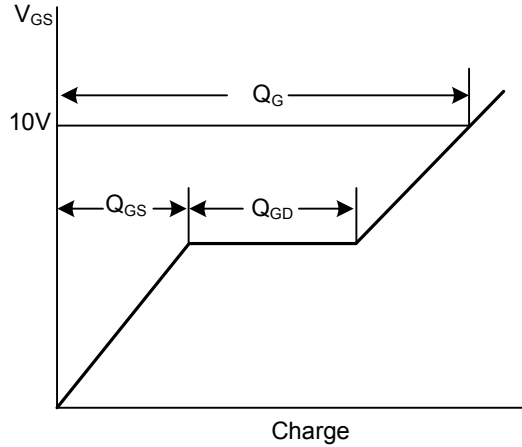

Resistive Switching Test Circuit

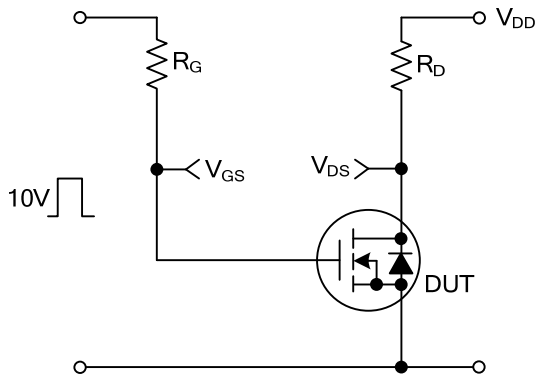

Resistive Switching Waveforms

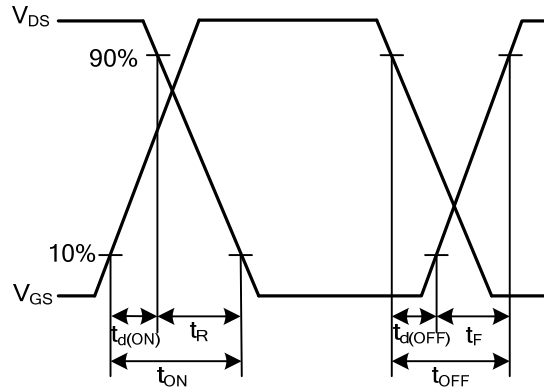

Unclamped Inductive Switching Test Circuit

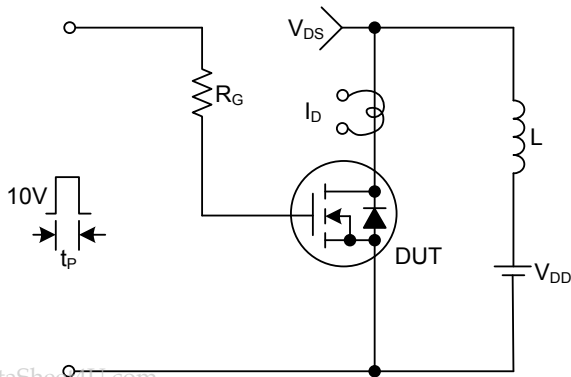

Unclamped Inductive Switching Waveforms

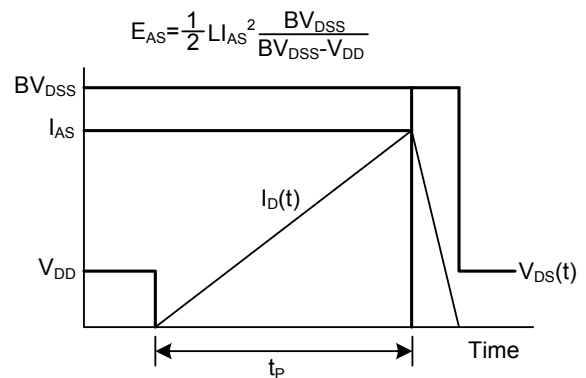

www.DataSheet4U.com

■ TEST CIRCUITS AND WAVEFORMS(Cont.)

Peak Diode Recovery dv/dt Test Circuit & Waveforms

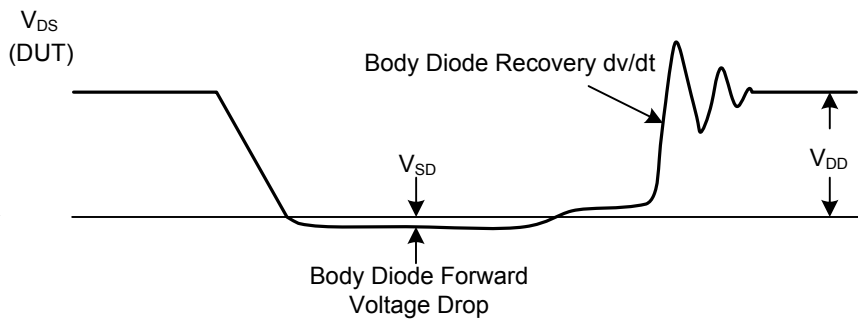
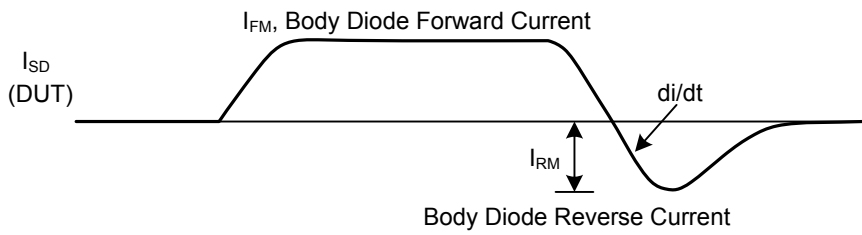
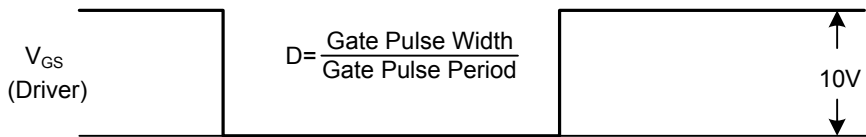
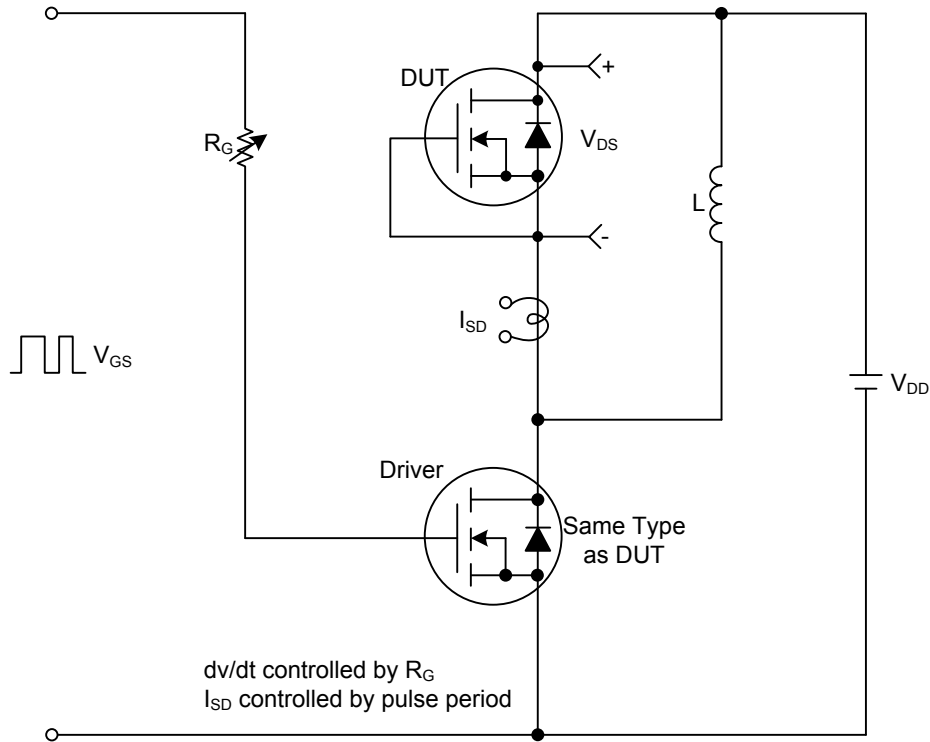

www.DataSheet4U.com

UTC assumes no responsibility for equipment failures that result from using products at values that exceed, even momentarily, rated values (such as maximum ratings, operating condition ranges, or other parameters) listed in products specifications of any and all UTC products described or contained herein. UTC products are not designed for use in life support appliances, devices or systems where malfunction of these products can be reasonably expected to result in personal injury. Reproduction in whole or in part is prohibited without the prior written consent of the copyright owner. The information presented in this document does not form part of any quotation or contract, is believed to be accurate and reliable and may be changed without notice.