

EVALUATION OF THE NEW HIGH VOLTAGE MDmesh™ VERSUS STANDARD MOSFETs

F. DiGiovanni - M. Laudani - M. Saggio - R. Scollo

1. ABSTRACT

The Multiple Drain Mesh, better known as MDmesh™, is a revolutionary technology as well as a “conceptual” breakthrough in the high voltage power MOSFET area. It is named after the combination of a new vertical drain structure with STMicroelectronics’ well established Mesh Overlay™ layout.

Figure 1: MDmesh™ Structure

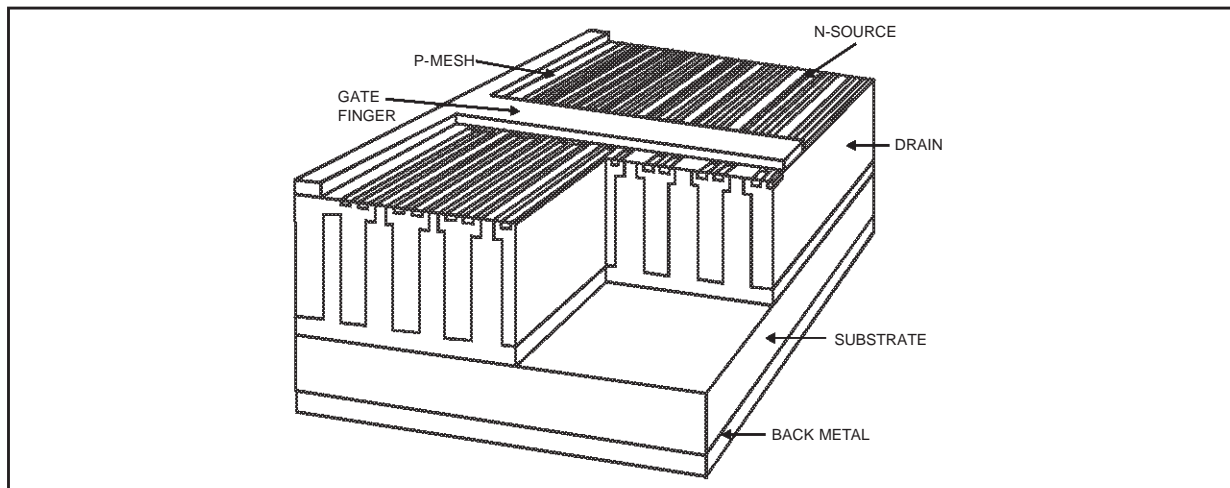

The process has a vertical p-stripe structure, made with an array of sections, that permits an increase of more than two times that of the average voltage breakdown. As a result, it is possible to cut the on-resistance within the range of 3 to 4, depending on the voltage rating. In fact, the new approach substantially reduces the resistance of a conventional lightly doped drain. This vertical structure achieves a very good charge balance in the drift region. Due to this a P-I-N diode is formed that accounts for the device’s voltage blocking capability. A MDmesh™ MOSFET designed to withstand 500V now exhibits the same drain resistance and lower thickness than those of a conventional 200V MOSFET with a much lower on-resistance. The new drain structure has been coupled to the STMicroelectronics’ Mesh Overlay™ horizontal layout which has enabled ST designers to maintain a perfect control of the internal gate resistance, in addition to substantially reducing gate charge. Another advantage over standard products stands in the law of the on-resistance variation as a function of temperature. As can be seen in figure 2, the thermal coefficient is just 1.7 at 125°C as opposed to greater than 2 in conventional high voltage MOSFETs. The final result is reduced power dissipation which makes improved system efficiency whereas the lower gate charge implies using smaller and more economic gate drives.

2. APPLICATION FIELDS.

The MDmesh™ used in the following application can be used in medium power SMPS applications such as those encountered in servers and high-end desktops. Other areas such as portable welding equipment can also benefit from the features of the new device. Advantages brought to the end user are maximized when all system implications are seen and not just the device itself. Switching losses are reduced because of lower intrinsic capacitance, shorter crossover time and much smaller gate charge (one-third of that of the conventional devices of similar on-resistance), whereas on-losses are decreased essentially because of $R_{DS(on)}$.

Figure 2: MDmesh™ $R_{DS(on)}$ versus Temperature

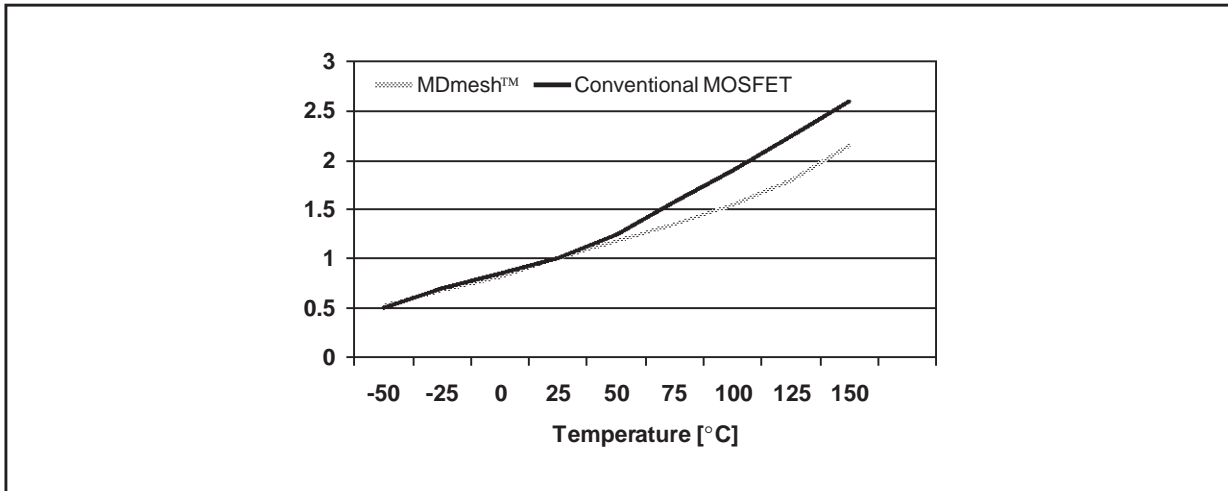

3. INTRODUCTION.

The purpose of the following analysis is to compare the electrical and thermal performance of the STW15NB50 standard MOSFET (500V, 0.36Ohm max, TO-247) with the new MDmesh™ (500V, 0.4Ohm max, TO-220) in a 360W power supply. The STW15NB50 already shows a better on-resistance than most similar 0.4Ohm industry products with its 0.36Ohm max. So it is expected that any performance gap between the MDmesh™ and similar competitors' devices can be wider than it is in our case. Also, in this analysis one can see how the new technology opens up new challenging opportunities to power conversion designers.

In the tests, the two MOSFETs were mounted in positions marked Q1 and Q2, as shown in figure 3 and under maximum nominal working operation. Our attention was focused on electrical and thermal parameters such as V_{gs} , V_{ds} , I_d , switching characteristics, operating frequency, duty-cycle, switching energy and steady state heatsink temperature. Based on the measurement results, some conclusions were drawn in order to evaluate all performance improvements and energy saving with the new MDmesh™ technology.

Figure 3: Circuit Configuration

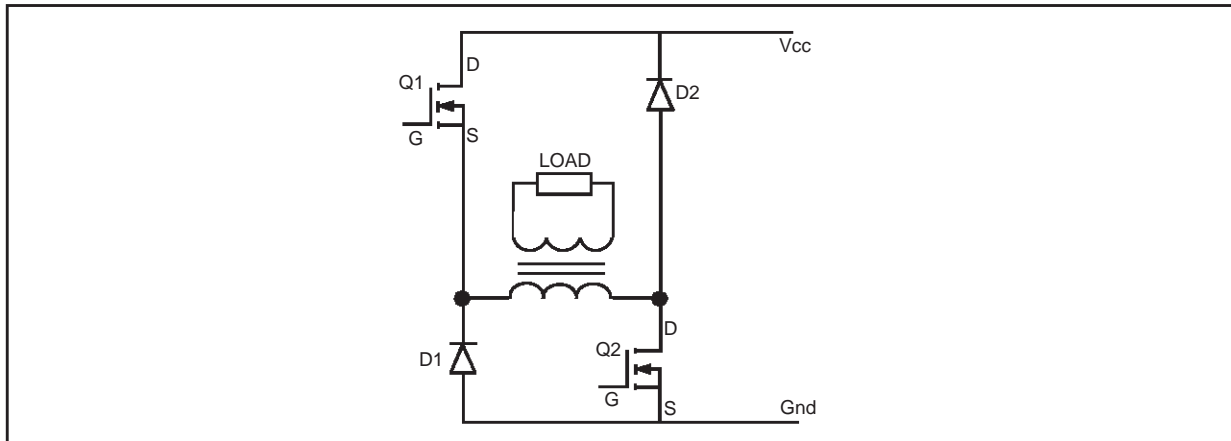

4. STATIC CHARACTERISTICS AND CIRCUIT CONFIGURATION

In the circuit, the devices are connected in an asymmetrical full bridge configuration (figure 3), where the load is the primary winding of a transformer.

The main static characteristics of the two devices under test are summarized in the below table.

Table 1: Main Electrical Characteristics

	V_{dss} [V]	$R_{DS(on)}$ @ 25°C [Ohm]	C_{iss} [pF]	C_{oss} [pF]	C_{rss} [pF]	Package
STW15NB30	>500	0.35	2,600	330	40	TO-247
MDmesh™	>500	0.37	930	160	25	TO-220

5. TEST DESCRIPTION AND OPERATION

The unit was supplied from 220VAC. Then, the +5V output was loaded with 0.084Ohm and the +12V output with 3Ohm, so that the total output power was 348W, very close to the maximum nominal output power. The normal operation of Q1 of both MOSFETs is shown in figure 2 when loaded as mentioned above.

The duty-cycle and frequency were not constant, as thought, but variable due to the voltage ripple from the PFC section. The duty-cycle ranged between 37% and 43% and the frequency between 110kHz and 120kHz.

Figures 4 and 5 show the turn-off of both devices. The MDmesh™, due to its lower capacitance, switched faster than the STW15NB50 (see table1).

Figure 4: MDmesh™ Turn-off

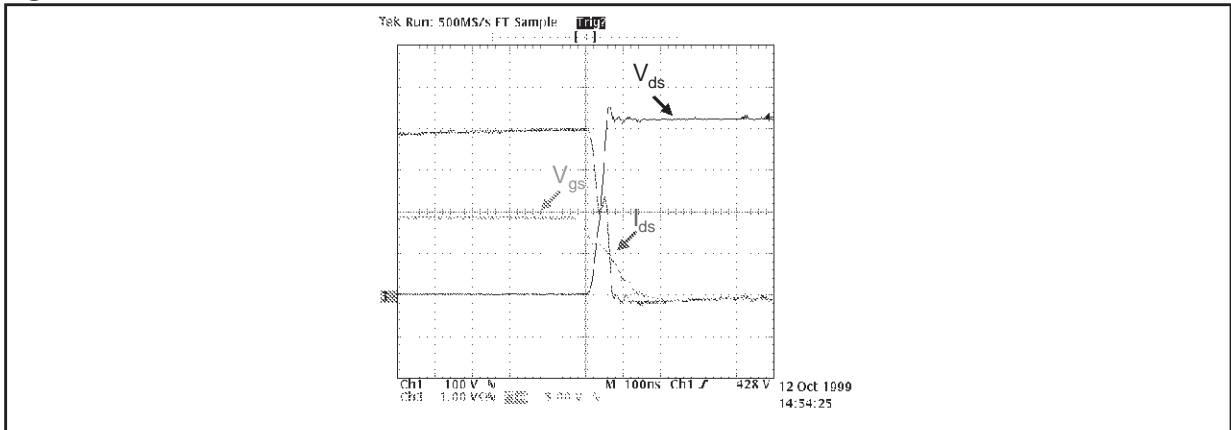
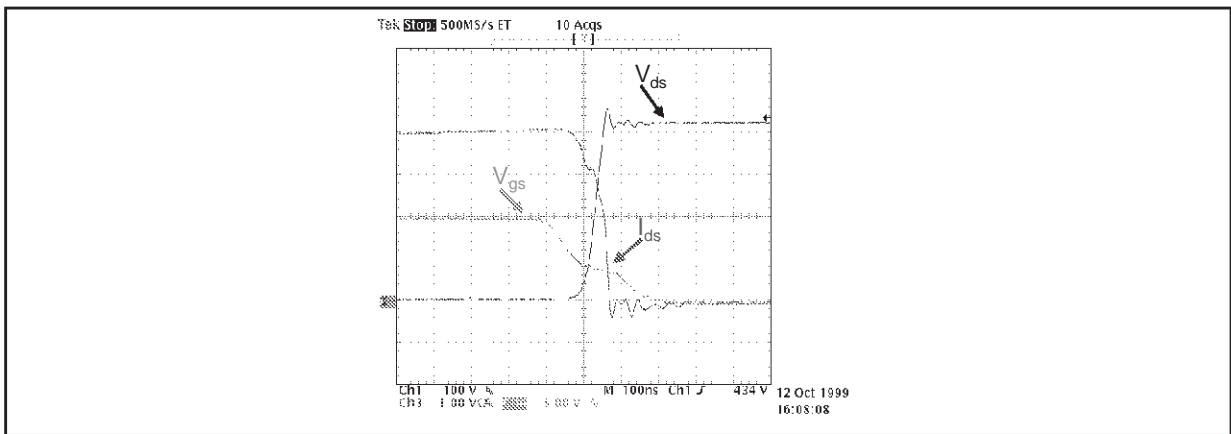

Figure 5: STW15NB50 Turn-off



In figure 6 and figure 7 the turn-on of both of the MOSFETs is compared and again the MDmesh™ is faster. In fact the gate-to-source voltage, V_{gs} , of the MDmesh™ takes about 100ns less to reach its maximum value (about 12V) compared to the STW15NB50.

Figure 6: MDmesh™ Turn-on

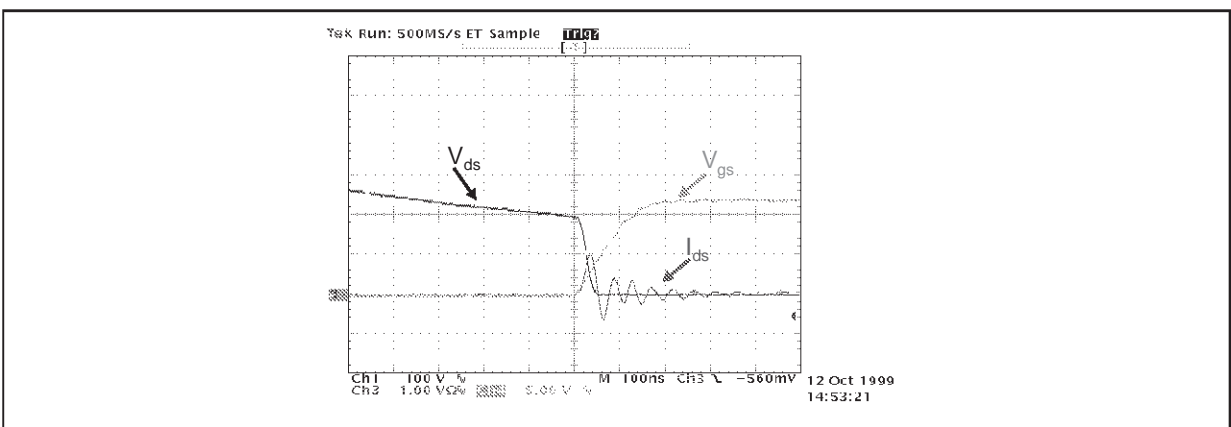
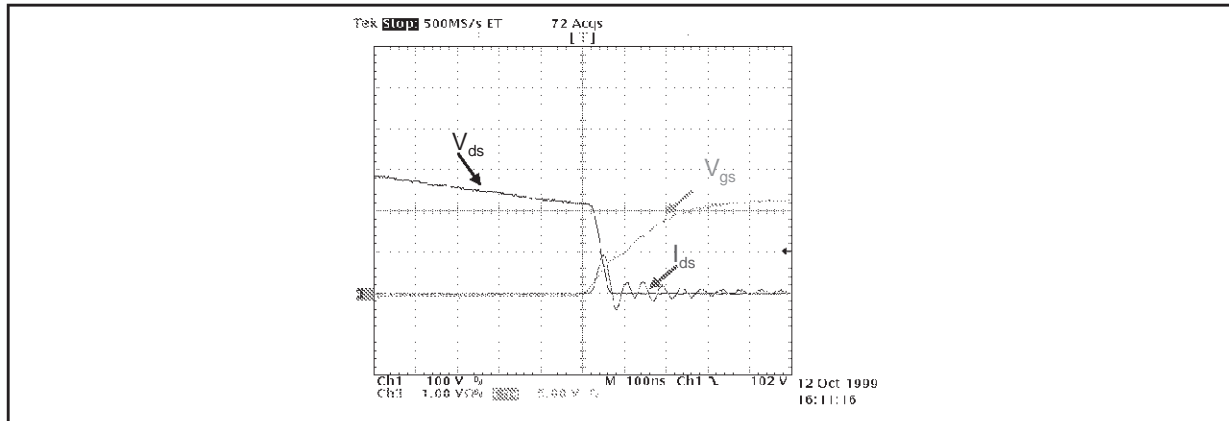

Figure 7: STW15NB50 Turn-on



6. TEMPERATURE MEASUREMENTS.

In order to perform a thermal comparison between the MDmesh™ and the STW15NB50 Q1 was mounted on a 11°C/W heatsink while Q2 was left on its original heatsink. Then the power supply was powered and loaded as mentioned before. Under these conditions, the steady state temperature was measured in a hole made in the heatsink underneath the device package. In table 2 the temperature measurements performed on the devices while the ambient temperature was around 25°C are summarized.

Table 2: Temperature Measurements

	Steady State Temperature
STW15NB50	102°C
MDmesh™	91°C

7. THERMAL CONSIDERATION.

Since the MDmesh™ temperature has been found to be 11°C lower than that of the STW15NB50, in the next step some consideration will be done in order to highlight the reasons behind the power saving and what is the predominant part (on-state or switching) allowing the MDmesh™ to operate more efficiently when compared to conventional technologies.

In spite of the voltage and current across them, the power MOSFETs are easily measurable. In this power supply their fast rate of change does not allow us to calculate the average power dissipation in steady state conditions. For this reason the power MOSFETs were mounted on the same heatsink (about 11°C/W of thermal resistance) used for the previous temperature measurement and biased with a DC voltage, giving the equivalent power needed to reach the same temperature measured in the application. In such a way the total power dissipation, P_{tot} , that in the actual application is the sum of two terms difficult to determine (switching and conduction), was found by just measuring two equivalent continuous parameters (current and voltage on the MOSFET).

8. TEST RESULTS.

Table 3: Test Results

	V _{ds} [V]	I _{ds} [A]	P _{diss} = V _{ds} * I _{ds} [W]	R _{DS(on)} @ oper. temp [mOhm]
STW15NB50	2.2	3.17	7	694
MDmesh™	1.95	2.98	5.8	653

From the previous test the R_{DS(on)} of the devices at their related temperatures were obtained.

Using the results of these measurements we can calculate the power saved by the new MDmesh™ technology compared to the standard one.

Knowing R_{DS(on)} for both devices, we can calculate the on-state losses in the application:

$$P_{on} = R_{DS(on)} \cdot I^2$$

And since the current is equal in both devices, we can also calculate the ratio between the on-state power losses:

$$\frac{P_{on}(STW15NB50)}{P_{on}(MDmesh)} = \frac{R_{DS(on)}(STW15NB50)}{R_{DS(on)}(MDmesh)} = 1.062$$

Basically the last equation proves that in on-state the STW15NB50 dissipates 6.2% more than the MDmesh™.

Furthermore, from the switching energy measurements we can calculate the ratio between both switching energies:

$$\frac{P_{sw}(STW15NB50)}{P_{sw}(MDmesh)} = \frac{31.3}{22.6} = 1.384$$

Switching losses of the STW15NB50 are also bigger in this case.

We still have extra information from the total power measurements performed with continuous parameters and more specifically we know:

$$P_{sw}(STW15NB50) + P_{on}(STW15NB50) = 7W$$

and

$$P_{sw}(MDmesh) + P_{on}(MDmesh) = 5.8W$$

Solving the equations (2) through (5) we can find the values of power loss in both the on-state and switching condition for both devices and these values are summarized in table 4.

Table 4: Switching and Conduction Losses

	Switching Losses [W]	Conduction Losses [W]
STW15NB50	3.6	3.4
MDmesh™	2.6	3.2

Now we can calculate the power saving allowed by the new MDmesh™ versus the standard MOSFET.

$$PS_{\text{switching}} = 3.6 - 2.6 = 1W$$

and

$$PS_{\text{switching}} = 3.4 - 3.2 = 0.2W$$

From the last two equations it turns out that most of the power is saved thanks to the improved switching characteristics of the new technology, while the conduction offers a big advantage in view of the difference in die size of the two devices.

The next step will be to estimate the junction temperature based on the $R_{DS(on)}$ measurements.

$R_{DS(on)}(T_j)=0.653\text{Ohm}$ and $R_{DS(on)}(25^\circ\text{C})=0.373\text{Ohm}$ are from the measurements performed on the MDmesh™. As the ratio is equal to 1.75, it is possible to read the junction temperature from the normalized on-resistance versus temperature curve. The junction temperature is about 105°C .

In the same way, knowing $R_{DS(on)}(T_j)=0.694\text{Ohm}$ and $R_{DS(on)}(25^\circ\text{C})=0.355\text{Ohm}$ for the STW15NB50 it is possible to find that its junction temperature is 111°C .

Now the junction temperatures found will be verified to be consistent with the values obtained by using a different approach. Since the total power loss is known as well as the thermal resistance of the two parts, keeping in mind that the MDmesh™ package is a TO-220 while the STW15NB50 is housed in TO-247, it is possible to write:

$$T_j = T_{\text{heat sink}} + (R_{\text{th-j-c}} + R_{\text{th-c-ins}} + R_{\text{th-ins}} + R_{\text{th-ins-heat sink}}) \cdot P_{\text{losses}}$$

where $R_{\text{th-c-ins}}$, $R_{\text{th-ins}}$, and $R_{\text{th-ins-heat sink}}$ represent the case-to-insulation, insulation layer, and insulation-to-heat sink thermal resistances.

Making the substitution in the last equation for both devices we have the following results:

$$T_{j-\text{MDmesh}} = 91 + (1 + 0.5 + 0.4 + 0.5) \cdot 5.8 = 104^\circ\text{C}$$

and

$$T_{j-\text{STW15NB50}} = 102 + (0.65 + 0.24 + 0.2 + 0.24) \cdot 7 = 111.3^\circ\text{C}$$

As seen, these two values are pretty much equal to the ones calculated using the dependence of $R_{DS(on)}$ from temperature.

9. CONCLUSION

The main advantage of using the new MDmesh™ technology is the remarkable reduction in the power loss which, in turn, allows a lower operating junction temperature even with smaller packages. A significant contribution to this power saving is achieved through a drastic improvement in its switching characteristics. In fact, a smaller die size and, above all, the optimized layout realized using ST unique technology, leads to devices with reduced intrinsic capacitances and gate charge. This means that the device can be operated at higher frequencies. In this case at 115kHz there is a reduced power consumption of about 28%.

The other contribution to the power saving is the conduction loss. That is, the higher the junction temperature the more pronounced the overall reduction in on-loss. For instance, with two devices exhibiting the same $R_{DS(on)}$ at 25°C, one with standard technology and the other in MDmesh™ version, it is possible to have a saving due to the contribution of $R_{DS(on)}$ of around 13%.

Information furnished is believed to be accurate and reliable. However, STMicroelectronics assumes no responsibility for the consequences of use of such information nor for any infringement of patents or other rights of third parties which may result from its use. No license is granted by implication or otherwise under any patent or patent rights of STMicroelectronics. Specification mentioned in this publication are subject to change without notice. This publication supersedes and replaces all information previously supplied. STMicroelectronics products are not authorized for use as critical components in life support devices or systems without express written approval of STMicroelectronics.

The ST logo is a registered trademark of STMicroelectronics

© 2001 STMicroelectronics - Printed in Italy - All rights reserved

STMicroelectronics GROUP OF COMPANIES

Australia - Brazil - China - Finland - France - Germany - Hong Kong - India - Italy - Japan - Malaysia - Malta - Morocco - Singapore - Spain - Sweden - Switzerland - United Kingdom - U.S.A.

<http://www.st.com>