

**Specification Status: Released**

**ABSOLUTE MAXIMUM RATINGS (Note 1)**

Parameter	Symbol	Value	Units
Max supply voltage	V <sub>IN</sub>	+8	V
Fault flag voltage	V <sub>FLG</sub>	+8	V
Fault flag current	I <sub>FLG</sub>	50	μA
Output voltage	V <sub>OUT</sub>	+8	V
Output current	I <sub>OUT</sub>	Internally limited	A
Control input	V <sub>EN</sub>	- 0.3 to +12.0	V
Storage temperature	T <sub>S</sub>	- 65 to +150	°C
Max lead temperature during soldering (5 sec.)		260	°C

**OPERATING RATINGS (Note 3)**

Parameter	Symbol	Value	Units
Supply voltage	V <sub>IN</sub>	+3 to +5.5	V
Continuous output current (each output)	I <sub>OUT</sub>	0.6	A
Ambient operating temperature	T <sub>A</sub>	-40 to +85	°C
Thermal resistance (DIP-8)	θ J <sub>A</sub>	120	°C/W

**ELECTRICAL CHARACTERISTICS (V<sub>IN</sub> = +5V; T<sub>A</sub> = 25°C; unless noted.)**

Power switch	Condition	Min	Typ	Max	Units
Switch Resistance	V <sub>IN</sub> = 5V, I <sub>OUT</sub> = 500mA, each switch		95	120	mΩ
	V <sub>IN</sub> = 3.3V, I <sub>OUT</sub> = 500mA, each switch		90	110	mΩ
Output Turn-On Time	R <sub>L</sub> = 10Ω each output, consists of delay+rise time		3.6	12	ms
Output Turn-Off Time	R <sub>L</sub> = 10Ω each output, consists of delay+fall time		2	40	μs

Current limit	Condition	Min	Typ	Max	Units
Short-Circuit Current Limit	Each output (enable into 0Ω load)	0.6	0.9	1.25	A
	Each output (3Ω load hot-plugged into EN device), V <sub>OUT</sub> = 4.0V	0.6	0.9	1.25	A

Enable input	Condition	Min	Typ	Max	Units
Enable Input Threshold	Low-to-high transition		1.5	2.4	V
	High-to-low transition, Note 4	0.8	1.5		V
Enable Input Current	V <sub>EN</sub> = 0V to 5.5V		0.01	1	μA
Enable Input Capacitance				5	pF

Supply current	Condition	Min	Typ	Max	Units
Supply Current	Switch off, OUT = open; Note 4		0.5	5	μA
	Switches on, OUT = open; Note 4		200	250	μA
Output Leakage Current	Each output (output disabled)			10	μA

OT, UVLO/OVLO	Condition	Min	Typ	Max	Units
Overtemperature Shutdown Threshold	T <sub>J</sub> increasing		135		C
	T <sub>J</sub> decreasing		125		C
UVLO Threshold	V <sub>IN</sub> = increasing		2.5		V
	V <sub>IN</sub> = decreasing		2.3		V
OVLO Threshold	V <sub>IN</sub> = increasing		6.4		V
	V <sub>IN</sub> = decreasing		6.1		V

Error flag	Condition	Min	Typ	Max	Units
Error Flag Output Resistance	V <sub>IN</sub> = 5V, I <sub>L</sub> = 10μA, Note 5		50	100	Ω
	V <sub>IN</sub> = 3.3V, I <sub>L</sub> = 10μA, Note 5		80	100	Ω
Error flag output delay	Fault on overcurrent, Note 6	6	9	15	ms
Error Flag Off Current	V <sub>FLAG</sub> = 5V		0.01	1	μA

**ELECTRICAL CHARACTERISTICS - NOTES**

- Note 1.** Exceeding the absolute maximum rating may damage the device.
- Note 2.** Devices are ESD sensitive. Handling precautions recommended.
- Note 3.** The device is not designed to function outside its operating rating.
- Note 4.** Off is  $\leq 0.8V$  and on is  $\geq 2.4V$  for the RYC8220-1 and RYC8220-3. Off is  $\geq 2.4V$  and on is  $\leq 0.8V$  for the RYC8220-2 and RYC8220-4. The enable input has approximately 200mV of hysteresis. Pull-down/Pull-up resistors are on chip for "-1" and "-2" configurations.
- Note 5.** Pull-up resistors are on chip.
- Note 6.** No error flag out delay on UVLO, OVLO, and thermal shut down.

**PIN CONFIGURATION:**

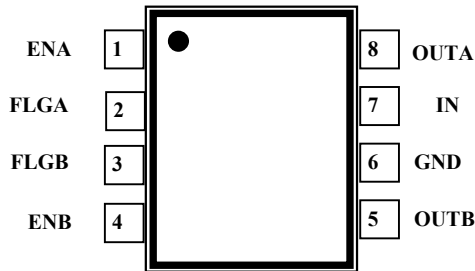

**DEVICE MARKING:**

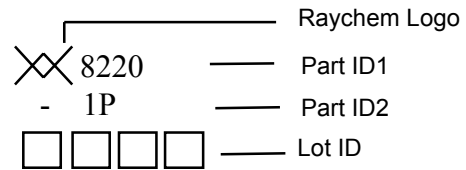

**PIN DESCRIPTIONS:**

Pin Number	Pin Name	Pin Function
1, 4	EN	Enable (Input): Logic-compatible enable input. High input > 2.4V typical. Low input < 0.8V typical (-1, -3 active high, -2, -4 active low). Do not float.
2, 3	FLG	Fault Flag (Output): Active-low open-drain output. Indicates overcurrent, UVLO, OVLO and thermal shutdown.
6	GND	Ground: Supply return
7	IN	Supply Input: Output MOSFET drain. Also supplies IC's internal circuitry. Connect to positive supply.
5 and 8	OUT	Switch Output: Output MOSFET source. Typically connect to switched side of load.

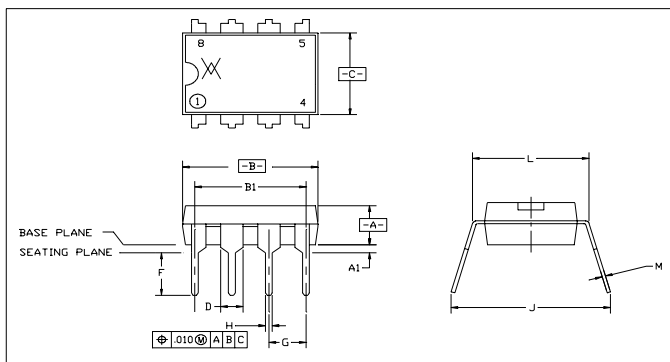

DIMENSION	MM		IN	
	MIN	MAX	MIN	MAX
A	3.05	3.81	0.120	0.150
A1	0.38	0.89	0.015	0.035
B	9.40	10.16	0.370	0.400
B1	7.62 BSC		0.300 BSC	
C	6.10	6.60	0.240	0.260
D	1.14	1.65	0.045	0.065
F	3.17	3.81	0.125	0.150
G	2.29	2.80	0.090	0.110
H	0.38	0.58	0.015	0.023
J	7.62	10.92	0.300	0.430
L	7.37	7.87	0.290	0.310
M	0.20	0.38	0.008	0.015

**MECHANICAL DIMENSIONS:**

**DIP-8 PACKAGE NOTES:**

1. Dimensions and tolerance per ANSI Y14.5M-1982.
2. Dimensions A, B, and C are datums.
3. Controlling dimensions: Inches
4. Dimensions B and C do not include mold flash. Mold flash shall not exceed 0.10 inch [0.25mm] per side.