

November 2005

Features

- DVB-C EN300429 and ITU-T J.83 annex A/C compliant QAM demodulator
- Conventional IF and low IF input supported
- QAM constellations 16, 32, 64, 128 and 256
- Symbol rates up to 9 MBaud
- Blind acquisition of all symbol rates
- Blind acquisition of QAM constellations
- Single IF filter bandwidth for all symbol rates
- Signal level, BER and SNR indicators
- Programmable IF/RF AGC take-over point
- Power down mode under software control
- Parallel and serial MPEG outputs
- External 4 or 27 MHz clock or single low-cost 10 MHz crystal
- Small package size LQFP64 7x7 mm
- Power consumption <300 mW at 6.9 MBaud
- 5 V tolerant 2-wire bus control interface
- 5 V tolerant GPIO port and AGC outputs
- RF level detect facility via a separate ADC
- Very low driver software overhead due to on-chip state-machine control.
- General purpose programmable timer

Applications

- Set-top boxes
- Digital cable ready TV applications
- Cable modems
- SMATV/MATV receivers

Ordering Information

ZL10210/GC/GP1N 64 Pin LQFP

-40°C to +85°C

Description

The ZL10210 is a DVB-C and ITU-T annex A/C QAM demodulator. This low power cable demodulator includes standard Zarlink features of auto signal acquisition, fast blind-scan capability, software/hardware power down, RF level, BER and SNR detection. The ZL10210 represents the latest in QAM demodulation for DVB cable. Together with a cable tuner, a full digital cable receiver front-end can be realized. Either conventional intermediate frequencies such as 36 or 44 MHz or low intermediate frequencies can be used - see application below. The ZL10210 requires only a single channel filter bandwidth of 8 MHz nominal for full DVB and ITU-T annex A/C performance. The low power consumption, small package form factor and integrated software/hardware power-down modes help reduce the system BoM (bill of materials) in cost sensitive applications. The device is packaged in a 7 x 7 mm 64-pin LQFP.

Functional Description

The ZL10210 accepts an analog signal from the tuner, either at low Intermediate Frequency (IF) or conventional IF up to 50 MHz, and delivers an MPEG2 compliant transport stream. It contains a single 10-bit

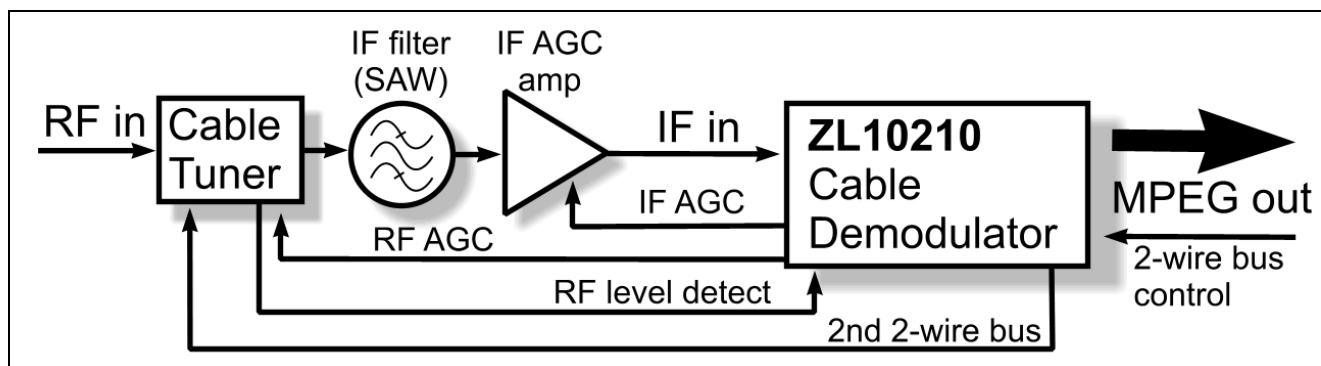

Figure 1 - System Diagram

analog-to-Digital Converter (ADC), a digital QAM demodulator and Forward Error Correcting (FEC) decoder. The QAM demodulator supports QAM constellations 16 to 256. Both the QAM demodulator and the FEC are DVB and ITU-T J.83 annex A/C compliant.

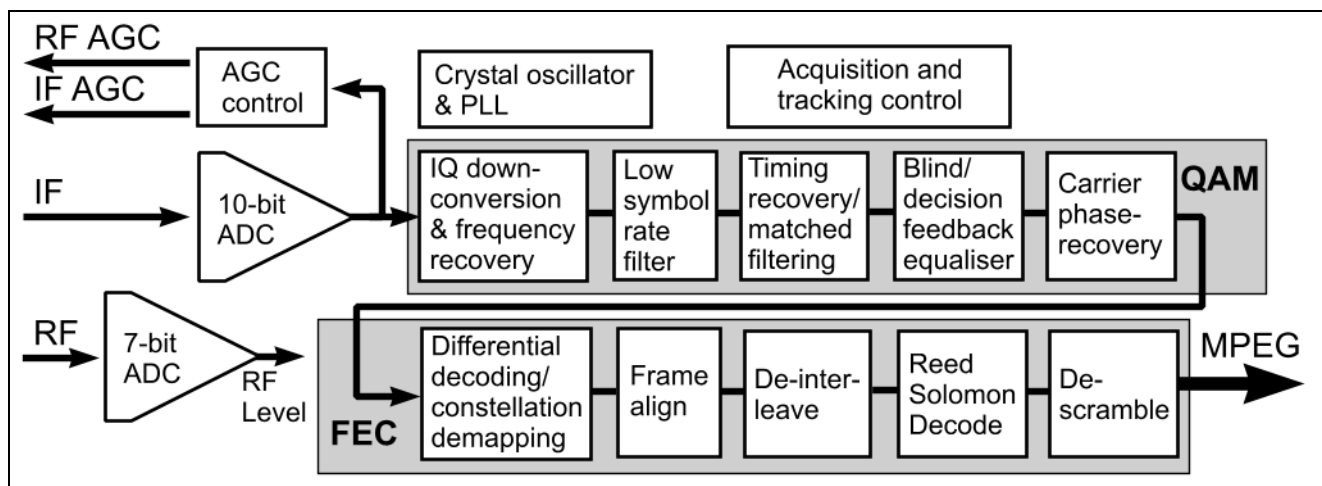

Figure 2 - ZL10210 Functional Diagram

The ADC uses a fixed sample rate greater than four times the maximum symbol rate. Hence for 1 to 9 MBaud applications, the signal has to be sampled at a frequency around 36 MHz. The spectrum of the analog signal being sampled may be located at near-zero IF (e.g. centered at 9 MHz) or it may be located at a conventional IF such as 36.2 MHz or 43.5 MHz.

First consider the case of IF sampling a 1 to 7 MBaud QAM signal centered at 36.2 MHz intermediate frequency. The sampling frequency chosen for this application is 28.9 MHz. This sampling process will fold the 36.2 MHz IF spectrum to one centered at 7.3 MHz.

Second consider the case of IF sampling a 1 to 6 MBaud QAM signal centered at 43.5 MHz IF. The sampling frequency chosen for this application is 25 MHz. This sampling process will result in a QAM spectrum centered at 6.5 MHz.

In the second case the sampling process results in spectral inversion. Even in first case the IF spectrum may be spectrally inverted. However, spectral inversion is not an issue with ZL10210 since it automatically detects and corrects for this in the digital domain.

The digital signal is first mixed down to baseband. However, as a result of tuning errors this signal will not be centered at zero frequency. ZL10210 has an automatic frequency control (AFC) loop that can track out tuning errors and hence in the tracking phase this signal will be centered at zero frequency. The AFC loop can typically compensate for +/-350 kHz frequency offsets. Larger offsets can be corrected by programming on-chip registers.

The baseband signal is filtered to reduce the effect of adjacent channels. Additional on-chip digital filtering is provided for low symbol rate applications. For example, it is possible to demodulate and decode a 1 MBaud QAM signal using only one external 8 MHz SAW filter.

ZL10210 has complete blind acquisition capability. It can automatically search and lock on to any QAM constellation in the set 16, 32, 64, 128 and 256. It can compensate for spectral inversion. It can also automatically acquire a symbol rate in the range 1 to 7 MBaud correcting for any tuning errors and adapting the filter bandwidths to signal bandwidth. All these functions are implemented using a sophisticated built-in control state machine with no software intervention.

The symbol-spaced equalizer in the ZL10210 is designed to acquire the QAM signal in blind mode, i.e., with no training sequence, and then to track the signal in the decision feedback mode. The equalizer has a feed-forward segment and a feedback segments. The tap partitioning between feed-forward and feedback is fully programmable.

The symbol timing and phase recovery functions with the ZL10210 are fully digital. The timing recovery phase locked loop has a built in timing sweep to enable the ZL10210 to lock on to unknown symbol rates. The phase recovery loop has been optimised to overcome phase noise degradation caused by typical tuners.

The ZL10210 QAM demodulator has built in control mechanisms to overcome signal degradation due to impulse noise in cable systems. The most significant bits of the demodulated I/Q symbols are differentially decoded to remove multiples of 90 degree phase ambiguity in demodulation. The QAM symbols are then demapped into a bit stream, using the constellation definitions provided by DVB and ITU-T. The number of bits per symbol is eight for QAM-256, seven for QAM-128, six for QAM-64, five for QAM-32 and four for QAM-16.

The bitstream is aligned into bytes and then into 204-byte frames by the Frame Alignment Unit. These frames are deinterleaved as defined by DVB to improve the resilience of the system to error bursts. The (204,188) Reed-Solomon decoder, which follows the deinterleaver, can correct up to eight byte-errors per frame. This also generates an uncorrectable error flag for blocks with more than eight byte-errors. In addition, the ZL10210 Reed-Solomon decoder keeps a count of the number of uncorrectable blocks and the number of bit errors corrected. The former will give an indication on the quality of the MPEG output and the latter provides the Bit Error Rate in QAM demodulation.

The decoder packets are then descrambled to reverse the energy dispersal function introduced by the transmitter. The output of the device is a stream of regularly spaced MPEG packets. The MPEG byte clock frequency is automatically adapted to be the minimum needed for a given symbol rate and QAM constellation. Alternatively the MPEG bytes can be clocked out using an externally provided byte clock. There is also an option for bit-serial output.

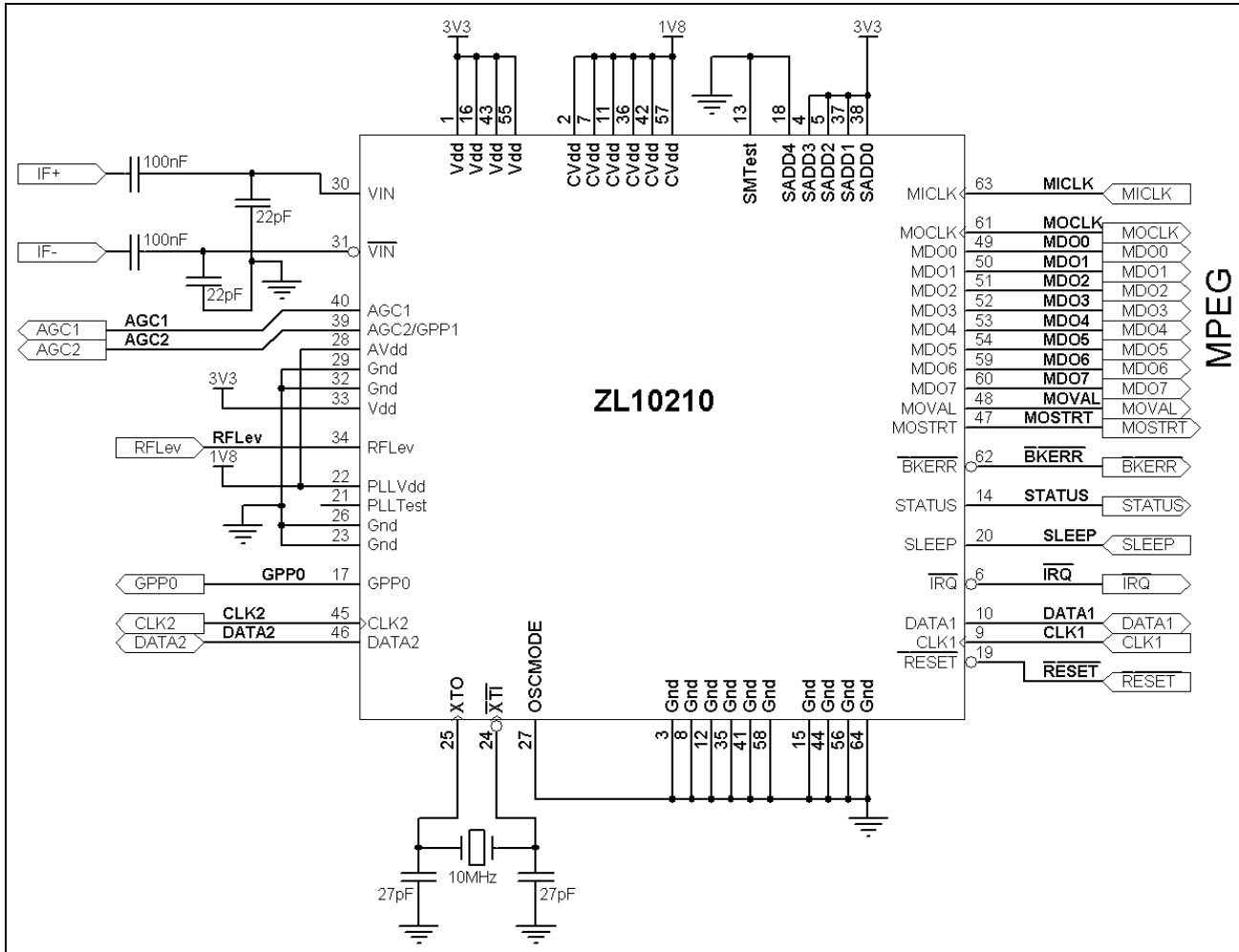

Figure 3 - Typical ZL10210 Application

1.0 Pin & Package Details

1.1 Pin Outline

Figure 4 below shows the pin functions of the ZL10210.

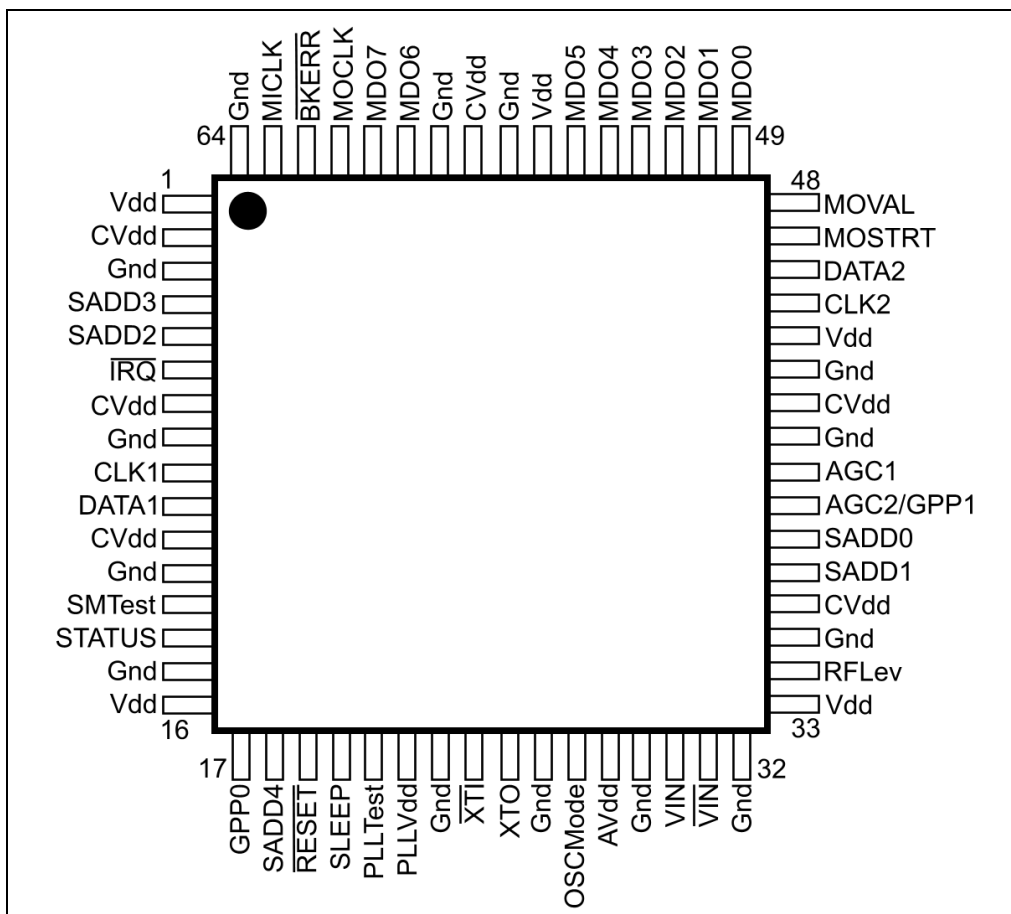

Figure 4 - Pin Outline

1.2 Pin Allocation

Pin	Function	Pin	Function	Pin	Function	Pin	Function
1	Vdd	17	GPP0	33	Vdd	49	MDO0
2	CVdd	18	SADD4	34	RFLev	50	MDO1
3	Gnd	19	$\overline{\text{RESET}}$	35	Gnd	51	MDO2
4	SADD3	20	SLEEP	36	CVdd	52	MDO3
5	SADD2	21	PLLTest	37	SADD1	53	MDO4
6	$\overline{\text{IRQ}}$	22	PLLVdd	38	SADD0	54	MDO5
7	CVdd	23	Gnd	39	AGC2/GPP1	55	Vdd
8	Gnd	24	XTI	40	AGC1	56	Gnd

Table 1 - Pin Names - numeric

Pin	Function	Pin	Function	Pin	Function	Pin	Function
9	CLK1	25	XTO	41	Gnd	57	CVdd
10	DATA1	26	Gnd	42	CVdd	58	Gnd
11	CVdd	27	OSCMODE	43	Vdd	59	MDO6
12	Gnd	28	AVdd	44	Gnd	60	MDO7
13	SMTTest	29	Gnd	45	CLK2	61	MOCLK
14	STATUS	30	VIN	46	DATA2	62	BKERR
15	Gnd	31	VIN	47	MOSTRT	63	MICLK
16	Vdd	32	Gnd	48	MOVAL	64	Gnd

Table 1 - Pin Names - numeric (continued)

Function	Pin	Function	Pin	Function	Pin	Function	Pin
AGC1	40	Gnd	12	MDO2	51	SADD1	37
AGC2/GPP1	39	Gnd	15	MDO3	52	SADD2	5
AVdd	28	Gnd	23	MDO4	53	SADD3	4
$\overline{\text{BKERR}}$	62	Gnd	26	MDO5	54	SADD4	18
CLK1	9	Gnd	29	MDO6	59	SLEEP	20
CLK2	45	Gnd	32	MDO7	60	SMTTest	13
CVdd	2	Gnd	35	MICLK	63	STATUS	14
CVdd	7	Gnd	41	MOCLK	61	Vdd	1
CVdd	11	Gnd	44	MOSTRT	47	Vdd	16
CVdd	36	Gnd	56	MOVAL	48	Vdd	33
CVdd	42	Gnd	58	OSCMODE	27	Vdd	43
CVdd	57	Gnd	64	PLLTest	21	Vdd	55
DATA1	10	GPP0	17	PLLVdd	22	VIN	30
DATA2	46	$\overline{\text{IRQ}}$	6	$\overline{\text{RESET}}$	19	$\overline{\text{VIN}}$	31
Gnd	3	MDO0	49	RFLV	34	$\overline{\text{XTI}}$	24
Gnd	8	MDO1	50	SADD0	38	XTO	25

Table 2 - Pin Names - alphabetical order

1.3 Pin Description

Pin Description Table

Pin No	Name	Pin Description	I/O	Type	V ¹	mA	
MPEG pins							
47	MOSTRT	MPEG packet start	O	CMOS Tristate	3.3	1	
48	MOVAL	MPEG data valid	O		3.3	1	
49-54, 59-60	MDO(0:5) MDO(6:7)	MPEG data outputs	O		3.3	1	
61	MOCLK	MPEG output clock	O		3.3	1	
62	$\overline{\text{BKERR}}$	Block error output	O		3.3	1	
63	MICLK	MPEG input clock	I	CMOS	3.3		
14	STATUS	Status output	O		3.3	1	
6	$\overline{\text{IRQ}}$	Interrupt output	O	Open drain	5	6	
Control pins							
9	CLK1	Serial clock	I	CMOS	5		
10	DATA1	Serial data	I/O	Open drain	5	6	
24	$\overline{\text{XTI}}$	Low phase noise crystal oscillator	I	CMOS	1.8		
25	XTO		I/O		1.8		
20	SLEEP	Device power down	I		5		
4, 5,18,37,38	SADD(4:0)	Serial address set	I		3.3		
13	SMTTest	Production test (only set low)	I		3.3		
45	CLK2	Serial clock tuner	I/O		Open drain	5	6
46	DATA2	Serial data tuner	I/O			5	6
40	AGC1	Primary AGC	O	5		6	
39	AGC2/GPP1	Secondary AGC or general I/O	I/O	5		6	
17	GPP0	General purpose I/O	I/O	5		6	
19	RESET	Device reset - active low	I	CMOS	5		

Pin Description Table (continued)

Pin No	Name	Pin Description	I/O	Type	v ¹	mA
27	OSCMODE	Crystal oscillator mode: Low = crystal oscillator High = external clock	I	CMOS	3.3	
21	PLLVDD	PLL test - do not connect	O	(tristated)		
Analog inputs						
30	VIN	ADC positive input	I	Analog input nominally ±400 mV AC coupled		
31	VIN	ADC negative input	I			
34	RFLVDD	RF level ADC input	I	Analog input nominally 3.3 V for max. level	3.3	
Supply pins						
28	AVDD	ADC analog supply ²	S		1.8	
2, 7, 11, 36, 42, 57	CVDD	Core logic power	S			
22	PLLVDD	PLL supply ²	S			
1, 16, 33, 43, 55	VDD	I/O ring power (#33 is to ADC only ²)	S		3.3	
3, 8, 12, 15, 23, 26, 29, 32, 35, 41, 44, 56, 58, 64	GND	Core, analog and I/O grounds ³	S		0	

1. This column is the nominal maximum for a given pin. Pins listed as 5 V can tolerate voltages up to 5 V (inputs have threshold voltages related to the 3V3 supply).

2. Pins #22, #28 and #33 should have separate supply lines from the digital supplies of the same voltage.

3. Decoupling capacitors should be used from every Gnd pin to its adjacent supply pin, with the capacitor as close as possible to the pins. Pin #26 is provided to allow the oscillator to be ringed.

2.0 Interfaces

2.1 2-wire Bus

2.1.1 Host

The primary 2-wire bus serial interface uses pins:

- DATA1 (pin #10) serial data, the most significant bit is sent first.
- CLK1 (pin #9) serial clock.

The 2-wire bus address is determined by applying Vdd or Gnd to the SADD[4:0] pins.

In CNIM evaluation applications, the 2-wire bus address is 0001 111 $\overline{R/W}$ with the pins connected as follows:

ADDR[7]	ADDR[6]	ADDR[5]	ADDR[4]	ADDR[3]	ADDR[2]	ADDR[1]
Not programmable		SADD[4]	SADD[3]	SADD[2]	SADD[1]	SADD[0]
Gnd	Gnd	Gnd	Vdd	Vdd	Vdd	Vdd

When the ZL10210 is powered up, the $\overline{\text{RESET}}$ pin 9 should be held low for at least 50 ms after Vdd has reached normal operation levels. As the $\overline{\text{RESET}}$ pin goes high, the logic levels on SADD[4:0] are latched as the 2-wire bus address. ADDR[0] is the R/W bit.

The circuit works as a slave transmitter with the address lsb set high or as a slave receiver with the lsb set low. In receive mode, the first data byte is written to the RADD virtual register, which forms the register address. The RADD register takes an 8-bit value that determines which of 256 possible register addresses is written to by the following byte. Not all addresses are valid and many are reserved registers that must not be changed from their default values. Multiple byte reads or writes will auto-increment the value in RADD, but care should be taken not to access the reserved registers accidentally.

Following a valid chip address, the 2-wire bus STOP command resets the RADD register to 00. If the chip address is not recognized, the ZL10210 will ignore all activity until a valid chip address is received. The 2-wire bus START command does NOT reset the RADD register to 00. This allows a combined 2-wire bus message, to point to a particular read register with a write command, followed immediately with a read data command. If required, this could next be followed with a write command to continue from the latest address. RADD would not be sent in this case. Finally, a STOP command should be sent to free the bus.

When the 2-wire bus is addressed (after a recognized STOP command) with the read bit set, the first byte read out is the contents of register 00.

2.1.2 Tuner

The ZL10210 has two GPP (general purpose port) pins which are normally configured to provide a secondary 2-wire bus, allowing the main serial bus to be connected through to the tuner only when it is necessary to communicate with the tuner.

This reduces the electrical noise seen by the tuner and improves the performance. The allocation of the pins is: pin 45 = CLK2 or GPP3; pin 46 = DATA2 or GPP2.

Pass-through mode is selected by setting register Tuner_Ctl (0x56) [b0] = '1', otherwise, if this bit is '0', then there is no connection between the two serial buses. In this same register, bit [b2] must also be set to a '1' to enable the pins for serial use rather than as general purpose port pins. See also register GPP_Ctl address 0x55 for details of using these pins as GPPs.

2.1.3 Examples of 2-wire Bus Messages:

KEY:	S	Start condition	W	Write (= 0)
	P	Stop condition	R	Read (= 1)
	A	Acknowledge	NA	NOT Acknowledge
	<i>Italics</i>	ZL10210 output	RADD	Register Address

Write operation - as a slave receiver:

S	DEVICE ADDRESS	W	A	RADD (n)	A	DATA (reg n)	A	DATA (reg n+1)	A	P
---	-------------------	---	----------	-------------	----------	-----------------	----------	-------------------	----------	---

Read operation - ZL10210 as a slave transmitter:

S	DEVICE ADDRESS	R	A	DATA (reg 0)	A	DATA (reg 1)	A	DATA (reg 2)	NA	P
---	-------------------	---	----------	------------------------	---	------------------------	---	------------------------	----	---

Write/read operation with repeated start - ZL10210 as a slave transmitter:

S	DEVICE ADDRESS	W	A	RADD (n)	A	S	DEVICE ADDRESS	R	A	DATA (reg n)	A	DATA (reg n+1)	NA	P
---	-------------------	---	----------	-------------	----------	---	-------------------	---	----------	------------------------	---	--------------------------	----	---

2.1.4 Primary 2-wire Bus Timing

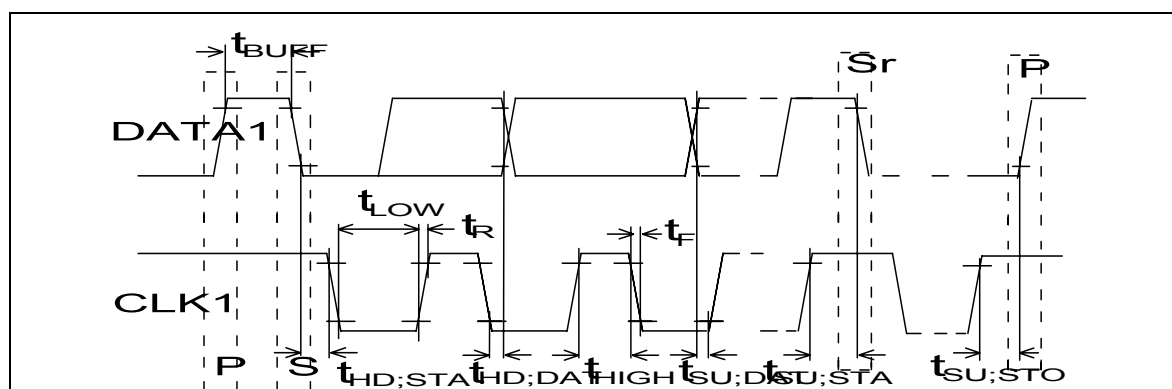

Figure 5 - Primary 2-wire Bus Timing

Where:

- S = Start
- Sr = Restart, i.e., start without stopping first
- P = Stop

Parameter	Symbol	Value		Unit
		Min.	Max.	
CLK clock frequency (Primary)	f_{CLK}	0	400 ¹	kHz
Bus free time between a STOP and START condition.	t_{BUFF}	200		ns
Hold time (repeated) START condition.	$t_{HD;STA}$	200		ns
LOW period of CLK clock.	t_{LOW}	1300		ns
HIGH period of CLK clock.	t_{HIGH}	600		ns
Set-up time for a repeated START condition.	$t_{SU;STA}$	200		ns
Data hold time (when input).	$t_{HD;DAT}$	100		ns
Data set-up time	$t_{SU;DAT}$	100		ns
Rise time of both CLK and DATA signals.	t_R		note ²	ns
Fall time of both CLK and DATA signals, (100pF to ground).	t_F	20		ns
Set-up time for a STOP condition.	$t_{SU;STO}$	200		ns

Table 3 - Timing of 2-Wire Bus

1. If operating with an external 4 MHz clock, the serial clock frequency is reduced to 100 kHz maximum.
2. The rise time depends on the external bus pull up resistor. Loading prevents full speed operation.

2.2 MPEG

2.2.1 Data Output Header Format

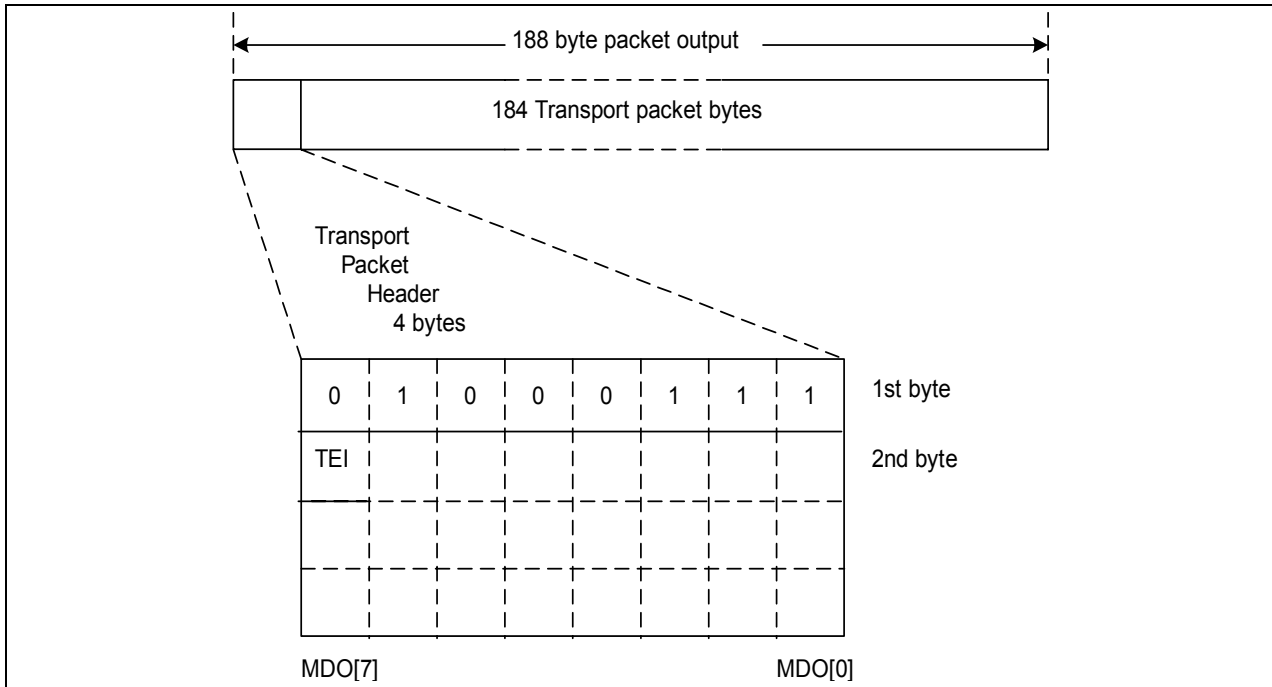

Figure 6 - DVB Transport Packet Header Byte

After decoding the 188-byte MPEG packet, it is output on the MDO pins in 188 consecutive clock cycles.

Additionally when the TEI_En bit in the MCLK_CTL register (0x77) is set high (default), the TEI bit of any uncorrectable packet will automatically be set to '1'. If TEI_En bit is low then TEI bit will not be changed (but note that if this bit is already 1, for example, due to a channel error which has not been corrected, it will remain high at output).

2.2.2 MPEG Data Output Signals

The MPEGEN bit in the CONFIG register must be set low to enable the MPEG data pins as outputs. The maximum movement in the packet synchronization byte position is limited to ± 1 output clock period. MOCLK will be a continuously running clock once symbol lock has been achieved, and is derived from the symbol clock. MOCLK is shown in Figure 7 with MOCLKINV = '1', the default state, see register 0x50.

All output data and signals (MDO[7:0], MOSTRT, MOVAL & $\overline{\text{BKERR}}$) change on the negative edge of MOCLK (MOCLKINV = 1) to present stable data and signals on the positive edge of the clock.

A complete packet is output on MDO[7:0] on 188 consecutive clocks and the MDO[7:0] pins will remain low during the inter-packet gaps. MOSTRT goes high for the first byte clock of a packet. MOVAL goes high on the first byte of a packet and remains high until the last byte has been clocked out. $\overline{\text{BKERR}}$ goes low on the first byte of a packet where uncorrectable bytes are detected and will remain low until the last byte has been clocked out.

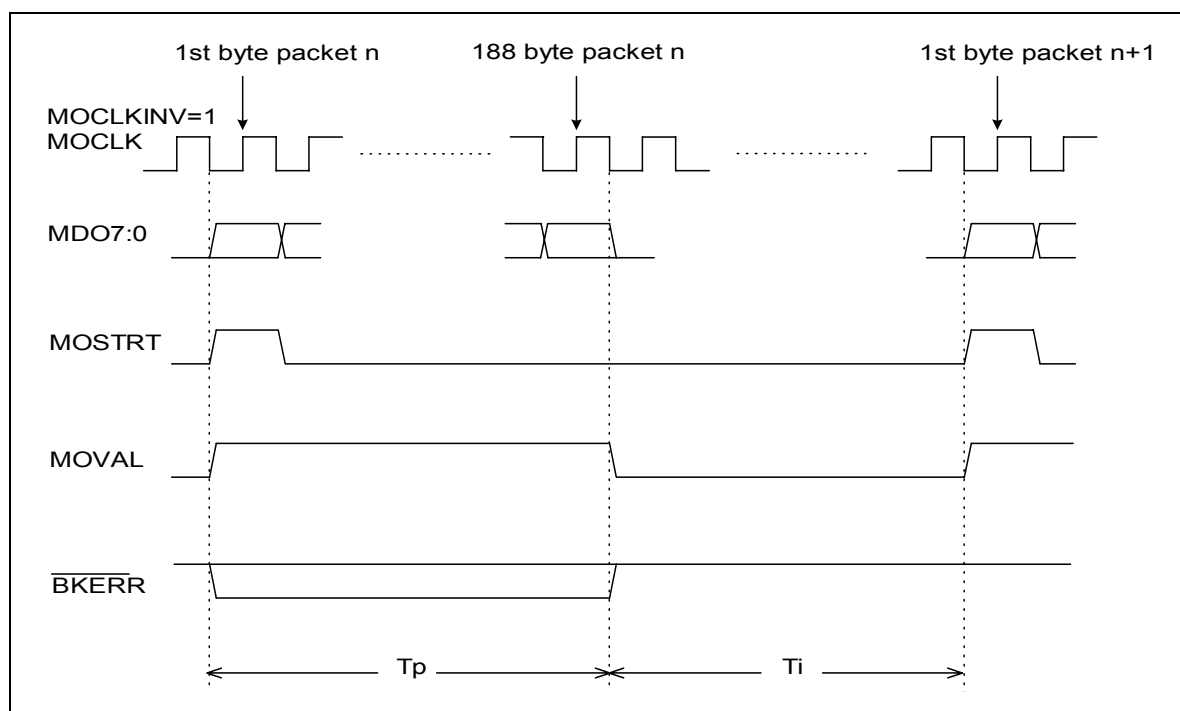

Figure 7 - MPEG Output Data Waveforms

2.2.3 MPEG Output Timing

Maximum delay conditions: $V_{dd} = 3.0\text{ V}$, $CV_{dd} = 1.62\text{ V}$, $T_{amb} = 85^\circ\text{C}$, Output load = 10 pF.

Minimum delay conditions: $V_{dd} = 3.6\text{ V}$, $CV_{dd} = 1.98\text{ V}$, $T_{amb} = -40^\circ\text{C}$, Output load = 10 pF.

MOCLK frequency = 45.06 MHz.

2.2.4 MOCLKINV = 1

Parameter	Delay Conditions		Units
	Maximum	Minimum	
Data output delay t_D	3.0	1.0	ns
Setup Time t_{SU}	7.0	10.0	
Hold Time t_H	7.0	10.0	

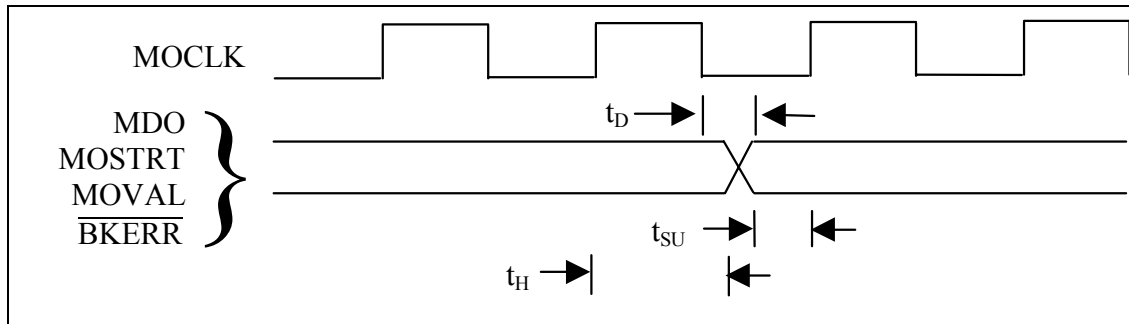

Figure 8 - MPEG Timing - MOCLKINV = 1

2.2.5 MOCLKINV = 0

MDOSWAP = 0

Parameter	Delay Conditions		Units
	Maximum	Minimum	
Data output delay t_D	3.0	1.0	ns
Setup Time t_{SU}	18.0	20.0	
Hold Time t_H	1.0	0.2	

The hold time is better when MOCLKINV = 1, therefore this should be used if possible.

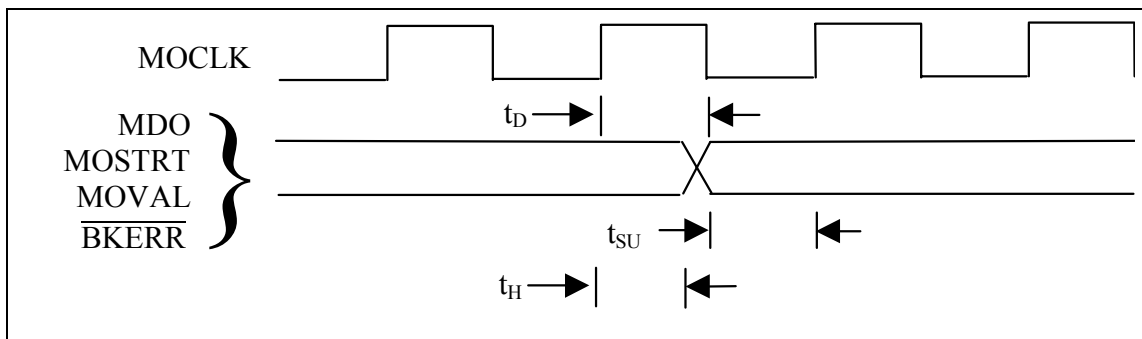

Figure 9 - MPEG Timing - MOCLKINV = 0

3.0 Electrical Characteristics

3.1 Recommended Operating Condition

Parameter	Symbol	Min.	Typ.	Max.	Units
Core power supply voltage	CVdd	1.71	1.8	1.89	V
Periphery power supply voltage	Vdd	3.13	3.3	3.47	V
Input clock frequency (note †)	Fxt1	3.99		27.01	MHz
Crystal oscillator frequency	Fxt2	9.99		16.01	MHz
CLK1 clock frequency ‡ (with 10 MHz or above)	Fclk1			400	kHz
Ambient operating temperature		-40		85	°C

†. When not using a crystal, XTI may be driven from an external source over the frequency range shown.

‡. The maximum serial clock speed on the primary 2-wire bus is related to the input clock frequency and is limited to 100 kHz with a 4.0 MHz clock.

3.2 Absolute Maximum Ratings

Maximum Operating Conditions

Parameter	Symbol	Min.	Max	Unit
Power supply	Vdd	-0.3	4.5	V
	CVdd	-0.3	2.3	
Voltage on input pins (5 V rated)	Vi	-0.3	5.5	V
Voltage on input pins (3.3 V rated)	Vi	-0.3	6.5	V
Voltage on input pins (1.8 V rated, e.g., $\overline{\text{XTI}}$)	Vi	-0.3	CVdd + 0.3	V
Voltage on output pins (5 V rated)	Vo	-0.3	5.5	V
Voltage on output pins (3.3 V rated)	Vo	-0.3	Vdd + 0.3	V
Voltage on output pins (1.8 V rated, e.g., XTO)	Vo	-0.3	CVdd + 0.3	V
Storage temperature	Tstg	-55	150	°C
Operating ambient temperature	Top	-40	85	°C
Junction temperature	Tj		125	°C
ESD protection (human body model)		4		kV

Note 1: Stresses exceeding these listed under 'Absolute Ratings' may induce failure. Exposure to absolute maximum ratings for extended periods may reduce reliability. Functionality at or above these conditions is not implied.

3.3 Crystal Specification

Parallel resonant fundamental frequency (preferred) 9.99 to 16.01 MHz.

Tolerance over operating temperature range ± 25 ppm.

Tolerance overall ± 50 ppm.

Nominal load capacitance 30 pF.

Equivalent series resistance $< 50 \Omega$

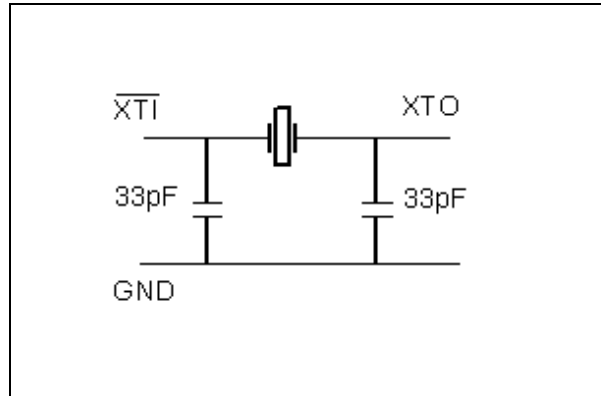

Figure 10 - Crystal Oscillator Circuit

3.3.1 Selection of External Components

The capacitor values used must ensure correct operation of the Pierce oscillator such that the total loop gain is greater than unity. Correct selection of the two capacitors is very important and the following method is recommended to obtain values for C1 and C2.

3.3.1.1 Loop Gain Equation

Although oscillation may still occur if the loop gain is just above 1, a loop gain of between 5 and 25 is optimum to ensure that oscillations will occur across all variations in temperature, process and supply voltage, and that the circuit will exhibit good start-up characteristics.

$$A = \frac{C_{out} \cdot g_m}{C_{in}} \left[\frac{C_{out} + C_{in}}{R_f \cdot C_{in}} + \frac{1}{Z_{in}} + \frac{1}{Z_o} \right]^{-1} \quad \text{- Equation 1}$$

$$Z_{in} = \frac{1}{(2 \cdot \pi \cdot f \cdot C_{out})^2 \cdot ESR} \quad \text{- Equation 2}$$

3.3.1.2 List of Equation Parameters

- A** total loop gain (between 5 and 25)
- Cin** C1 + Cpar
- Cout** C2 + Cpar
- Cpar** parasitic capacitance associated with each oscillator pin (\overline{XTI} and XTO). It consists of track capacitances, package capacitance and cell input capacitance. Normally Cpar ≈ 4 pF.
- Zo** 9.143 k Ω - output impedance of amplifier at 1.8 V operation - typical

gm	8.736mA/V - transconductance of amplifier at 1.8 V operation -typical
Rf	2.3MΩ - internal feedback resistor
ESR	maximum equivalent series resistance of crystal - given by crystal manufacturer (Ω)
f	fundamental frequency of crystal (Hz)

3.3.1.3 Calculating Crystal Power Dissipation

To calculate the power dissipated in a crystal the following equation can be used:

$$P_c = \frac{V_{pp}^2}{8 \cdot Z_{in}} \quad \text{- Equation 3}$$

Pc = power dissipated in crystal at resonant frequency (W)

Vpp = maximum peak to peak output swing of amplifier is 1.8 V for all CVdd

Zin = crystal network impedance (see Equation 2)

3.3.1.4 Capacitor Values

Using the loop gain limits ($5 \leq A \leq 25$), the maximum and minimum values for C1 and C2 can be calculated with Equation 4 below.

$$C_{in} = C_{out} = \sqrt{\left[\frac{g_m}{A} - \frac{2}{R_f} - \frac{1}{Z_o} \right] \cdot \frac{1}{(2 \cdot \pi \cdot f)^2 \cdot ESR}} \quad \text{when: } C_1 = C_2 = C_{out} - C_{par} \quad \text{- Equation 4}$$

Note: Equation 4 was derived from Equation 1 and Equation 2 using the premise that $C_1 = C_2$.

Within these limits, any value for C1 and C2 can now be selected. Normally C1 and C2 are chosen such that the resulting crystal load capacitance C_L (see Equation 5) is close to the crystal manufacturers recommended C_L (standard values for C_L are 15 pF, 20 pF and 30 pF). The crystal will then operate very near its specified frequency.

$$C_L = \frac{C_{out} \cdot C_{in}}{C_{out} + C_{in}} + C_{par12} \quad \text{- Equation 5}$$

C_{par12} = parasitic capacitance between the \overline{XTI} and XTO pins. It consists of the IC package's pin-to-pin capacitance (including any socket used) and the printed circuit board's track-to-track capacitance.

C_{par12} ≈ 2pF.

If some frequency pulling can be tolerated, a crystal load capacitance different from the crystal manufacturer's recommended C_L may be acceptable. Larger values of C_L tend to reduce the influence of circuit variations and tolerances on frequency stability. Smaller values of C_L tend to reduce startup time and crystal power dissipation. Care must however be taken that C_L does not fall outside the crystal pulling range or the circuit may fail to start up altogether. It is also possible to quote C_L to the crystal manufacturer who can then cut a crystal to order which will resonate, under the specified load conditions, at the desired frequency.

Finally the power dissipation in the crystal must be checked. If P_c is too high C1 and C2 must be reduced. If this is not feasible C2 alone may be reduced. Unbalancing C1 and C2 will, however, require checking if the loop gain condition is still satisfied. This must be done using Equation 1.

$$\text{Note: } 2 \geq \frac{C_2}{C_1} \geq 0.5$$

3.3.1.5 Oscillator/Clock Application Notes

- On the printed circuit board, the tracks to the crystal and capacitors must be made as short as possible. Other signal tracks must not be allowed to cross through this area. The component tracks should preferably be ringed by a ground track connected to the chip ground (0 V) on adjacent pins either side of the crystal pins. It is also advisable to provide a ground plane for the circuit to reduce noise.
- External clock signals, applied to \overline{XTI} and/or XTO, **must not exceed the cell supply limits (i.e., 0 V and CVdd)** and current into or out of \overline{XTI} and/or XTO must be limited to less than 10mA to avoid damaging the cell's amplitude clamping circuit.
- An external, DC coupled, single ended square wave clock signal may be applied to \overline{XTI} if OSCMODE = 0. To limit the current taken from the signal source a resistor should be placed between the clock source and \overline{XTI} . The recommended value for this series resistor is 470 Ω for a clock signal switching between 0 V and CVdd (1V8). The current the clock source needs to source/sink is then ≤ 1.9 mA. The XTO pin must be left unconnected in this configuration.
- AC coupling of a single ended external clock to \overline{XTI} , with OSCMODE = 0, is not recommended. The duty cycle of the OSCOUT signal cannot be guaranteed in such a configuration.
- AC coupling of a single ended external clock to \overline{XTI} , with OSCMODE = 1, is possible. It is recommended that the circuit shown in Figure 11 be used to correctly bias the oscillator inputs: The common-mode voltage VCM for \overline{XTI} and XTO, (set by the 15 k Ω and 22 k Ω resistors) must be $800 \text{ mV} < V_{CM} < CV_{dd}$ and the amplitude Vpp of the clock signal must be $> 400 \text{ mV}$.

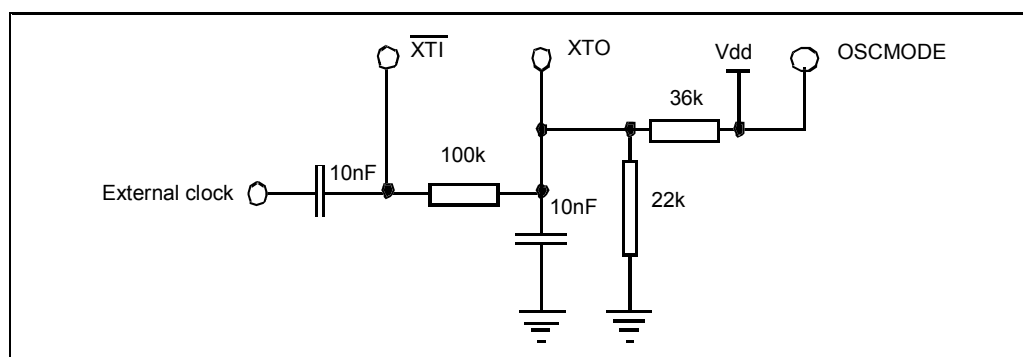

Figure 11 - External Clocking via AC Coupling

- External, differential clock signals may be applied to \overline{XTI} and XTO if OSCMODE = 1. The common-mode voltage VCM for the differential clock signals must be $800 \text{ mV} < V_{CM} < CV_{dd}$, and the peak-to-peak signal amplitude Vpp must be $> 400 \text{ mV}$. It is recommended that differential clock signals have $V_{CM} = 1.0 \text{ V}$. For $V_{pp} > 400 \text{ mV}$ a resistor of $\geq 390 \Omega$ in series with \overline{XTI} or XTO may be required to limit the current taken from or supplied to the clock sources.

3.4 Electrical Characteristics

Conditions (unless specified otherwise): $T_{amb} = 25^{\circ}\text{C}$ $C_{Vdd} = 1.8\text{ V}$ $V_{dd} = 3.3\text{ V}$

DC Electrical Characteristics

Parameter	Conditions/Pin	Symbol	Min.	Typ.	Max.	Unit
Core voltage		CVdd	1.71	1.8	1.89	V
Peripheral voltage		Vdd	3.13	3.3	3.47	V
Core current	Default settings	CIdd		120		mA
Peripheral current		Idd		2.2		mA
Total power		Ptot1		223		mW
Total power (stand-by)	ADCs powered down. MPEG outputs tri-stated	Ptot2		2.55		mW
Total power (sleep)	Pin 20 = logic '1' & ADCs powered down	Ptot3		0.10		mW
Output low level	2, 6 or 12 mA per output (see section 1.3, Pin Description)	Vol			0.4	V
Output high level	2, 6 or 12 mA per output	Voh	2.4			V
Output leakage	Tri-state when off or open-drain when high				± 1	μA
Output capacitance	All outputs except XTO, CLK1 & open-drain types. Excludes packaging contribution ($\sim 0.35\text{pF}$)			2.7		pF
	Open-drain outputs. Excludes packaging contribution ($\sim 0.35\text{pF}$)			3.3		pF
Input low level		Vil			0.8	V
Input high level		Vih	2.0			V
Input leakage	$V_{in} = 0$ or V_{dd}				± 1	μA
Input capacitance	Excludes packaging contribution ($\sim 0.35\text{pF}$)			1.5		pF

AC Electrical Characteristics

Parameter	Conditions/Pin	Min.	Typ.	Max.	Unit
ADC Full-scale input single range (single-ended or differential)	Differential source is recommended		1.6		V _{pp}
ADC analog input resistance	Per input pin		25		kΩ
ADC input common mode voltage level			0.9 [†]		V
RF ADC Full-scale input single range (single-ended)			3.3		V _{pp}
RF ADC analog input resistance			25		kΩ
RF ADC input common mode voltage			1.65 [‡]		V
System clock frequency		30.00		100	MHz
Input clock frequency (note ^{††})	See Section 3.3.1.5 for details.	3.99		27.01	MHz
Crystal oscillator frequency	See Section 3.3 for details	9.99		16.01	MHz
CLK1 clock frequency ^{‡‡} (with 10 MHz xtal or above)				400	kHz
MPEG clock input frequency	On pin #63	note ^{†††}		65 ^{‡‡‡}	MHz

[†]. Actually CV_{dd}/2

[‡]. Actually V_{dd}/2

^{††}. When not using a crystal, \overline{XTI} may be driven from an external source over the frequency range shown.

^{‡‡}. The maximum serial clock speed on the primary 2-wire bus is related to the input clock frequency and is limited to 100 kHz with a 4.0 MHz clock.

^{†††}. Must be calculated from the data input rate.

^{‡‡‡}. Must be lower than the system clock.

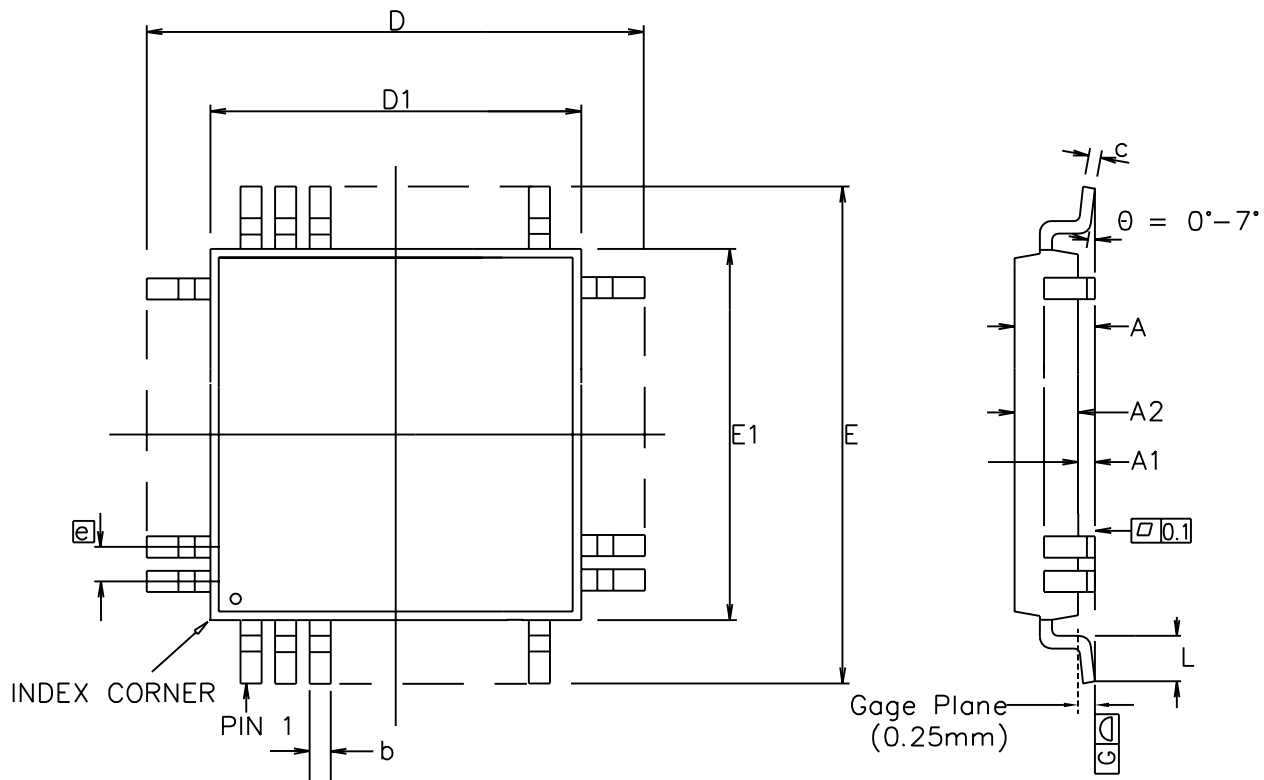

Symbol	Control Dimensions in millimetres		Altern. Dimensions in inches	
	MIN	MAX	MIN	MAX
A	---	1.60	---	0.063
A1	0.05	0.15	0.002	0.006
A2	1.35	1.45	0.053	0.057
D	9.00	BSC	0.354	BSC
D1	7.00	BSC	0.276	BSC
E	9.00	BSC	0.354	BSC
E1	7.00	BSC	0.276	BSC
L	0.45	0.75	0.018	0.030
e	0.40	BSC	0.016	BSC
b	0.13	0.23	0.005	0.009
c	0.09	0.20	0.004	0.008
Pin features				
N	64			
ND	16			
NE	16			
NOTE	SQUARE			

Conforms to JEDEC MS-026 BBD Iss. C

Notes:

1. Pin 1 indicator may be a corner chamfer, dot or both.
2. Controlling dimensions are in millimeters.
3. The top package body size may be smaller than the bottom package body size by a max. of 0.15 mm.
4. Dimension D1 and E1 do not include mould protrusion.
5. Dimension b does not include dambar protrusion.
6. Coplanarity, measured at seating plane G, to be 0.08 mm max.

This drawing supersedes 418/ED/51210/031 (Swindon)

© Zarlink Semiconductor 2002 All rights reserved.				 ZARLINK SEMICONDUCTOR	Package Code	QC
ISSUE	1	2	3		Previous package codes	Package Outline for 64 lead LQFP (7 x 7 x 1.4mm) 2mm Footprint
ACN	201370	207115	212445		GP / B	
DATE	29Oct96	9Jul99	26Mar02			
APPRD.						GPD00250



**For more information about all Zarlink products
visit our Web Site at
www.zarlink.com**

Information relating to products and services furnished herein by Zarlink Semiconductor Inc. or its subsidiaries (collectively "Zarlink") is believed to be reliable. However, Zarlink assumes no liability for errors that may appear in this publication, or for liability otherwise arising from the application or use of any such information, product or service or for any infringement of patents or other intellectual property rights owned by third parties which may result from such application or use. Neither the supply of such information or purchase of product or service conveys any license, either express or implied, under patents or other intellectual property rights owned by Zarlink or licensed from third parties by Zarlink, whatsoever. Purchasers of products are also hereby notified that the use of product in certain ways or in combination with Zarlink, or non-Zarlink furnished goods or services may infringe patents or other intellectual property rights owned by Zarlink.

This publication is issued to provide information only and (unless agreed by Zarlink in writing) may not be used, applied or reproduced for any purpose nor form part of any order or contract nor to be regarded as a representation relating to the products or services concerned. The products, their specifications, services and other information appearing in this publication are subject to change by Zarlink without notice. No warranty or guarantee express or implied is made regarding the capability, performance or suitability of any product or service. Information concerning possible methods of use is provided as a guide only and does not constitute any guarantee that such methods of use will be satisfactory in a specific piece of equipment. It is the user's responsibility to fully determine the performance and suitability of any equipment using such information and to ensure that any publication or data used is up to date and has not been superseded. Manufacturing does not necessarily include testing of all functions or parameters. These products are not suitable for use in any medical products whose failure to perform may result in significant injury or death to the user. All products and materials are sold and services provided subject to Zarlink's conditions of sale which are available on request.

Purchase of Zarlink's I²C components conveys a licence under the Philips I²C Patent rights to use these components in and I²C System, provided that the system conforms to the I²C Standard Specification as defined by Philips.

Zarlink, ZL and the Zarlink Semiconductor logo are trademarks of Zarlink Semiconductor Inc.

Copyright Zarlink Semiconductor Inc. All Rights Reserved.

TECHNICAL DOCUMENTATION - NOT FOR RESALE
