

VSC9271

10GB/s Multi-Rate Bi-directional FEC Device with Digital Wrapper and Performance Monitor



BENEFITS:

- ▶ Forward Error Correction techniques conform to industry standards
- ▶ Transparent error detection and correction for any client signal regardless of protocol or rate up to 10.3125Gb/s
- ▶ Bi-directional architecture enables independent FEC encode and decode operation
- ▶ Extensive Performance Monitoring and Regeneration Capabilities for SONET/SDH signals, GbE, and Fiber Channel
- ▶ Regenerator mode allows the device to be used as an FEC link regenerator (decode, then encode) for repeater applications

FEATURES:

- ▶ G.975 Reed-Solomon Encoding and Decoding RS(255,239) for client signals up to 10.3125Gb/s
- ▶ Digital Wrapper Support (G.709)
- ▶ Full programmability of G.709/G.975 Overhead
- ▶ Insertion/Extraction of OCh and client overhead bytes via dedicated access ports
- ▶ Bidirectional SONET/SDH Performance Monitoring for STS-192/STM-64, STS-48/STM-16, STS-12/STM-4, STS-3/STM-1 signals
- ▶ SONET/SDH Line Termination Capabilities
- ▶ B1/B2 Error Detection, Re-calculation, and Insertion
- ▶ SONET/SDH Section & Line AIS Insertion
- ▶ Bidirectional Gigabit Ethernet and Fibre Channel Performance Monitoring
- ▶ Integrated Bit Error Rate Monitors
- ▶ LOF/LOS/SD/SF/REI/RDI Alarm Generation

MARKETS:

- ▶ Metro Area Networking Products
- ▶ Long Haul Transmission Products

APPLICATIONS:

- ▶ Line cards
- ▶ Transponders
- ▶ Digital Cross Connects
- ▶ OADM
- ▶ Regenerators

BI-DIRECTIONAL FUNCTIONALITY:

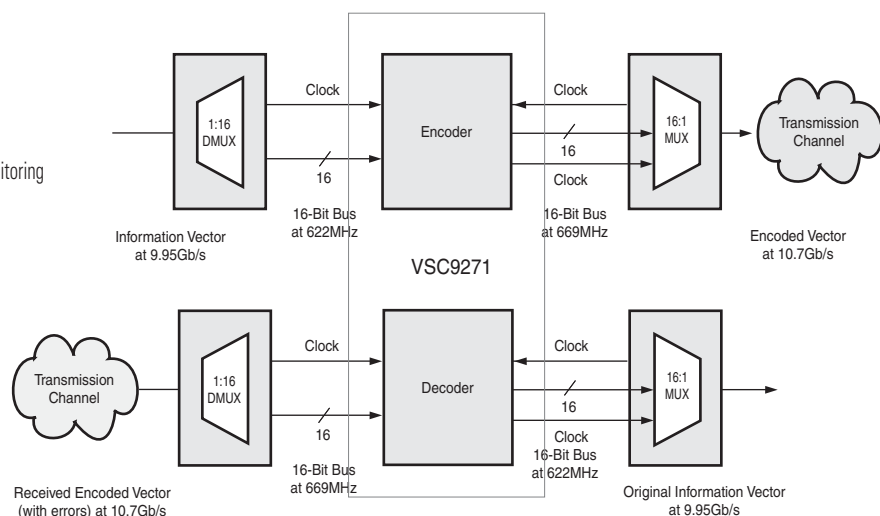

10GB/s Multi-Rate Bi-directional FEC Device with Digital Wrapper and Performance Monitor

GENERAL DESCRIPTION:



The VSC9271 is a multi-rate bidirectional Forward Error Correction Device (FEC) with Digital Wrapper and performance monitoring. The VSC9271 employs a bidirectional architecture that can be used in both transceiver (adaptation) and regenerator modes. In both cases performance monitoring at the client signal level may be performed for STS-192/STM-64, STS-48/STM-16, STS-12/STM-4, STS-3/STM-1, Gigabit Ethernet (GbE), and Fibre Channel (FC) signals. The flexible design of the VSC9271 enables the device to be used in a variety of applications with and without FEC. The VSC9271 conforms to the ITU-T G.975 standard for transparent FEC. The FEC is supported by the Optical Channel (OCh) which has its own set of performance monitoring and maintenance features defined by the ITU-T G.709 standard. These features are independent of the client signal carried, simplifying the operation of an optical network supporting various client signals. The VSC9271 offers bidirectional adaptation and regeneration capabilities for OCh signals.

An integrated multi-rate bidirectional performance monitor (PM) supports a variety of client signals. For SONET/SDH, the device monitors and modifies the transport (section and line) overhead of STS-192/STM-64, STS-48/STM-16, STS-12/STM-4, and STS 3/STM-1 client signals, which allows for support of Operations, Administration, Management, and Provisioning (OAM&P) functions. In addition to SONET/SDH, the VSC9271 supports the monitoring of GbE and FC signals, as well as a bypass mode to support any other data format.

VSC9271 BLOCK DIAGRAM:

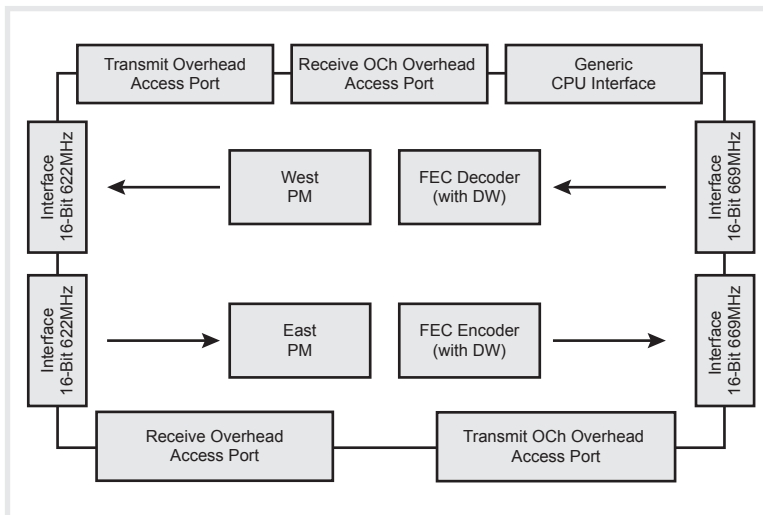

SPECIFICATIONS:

- ▶ +1.8V / +2.5 V Power Supply
- ▶ 3.5W Power Dissipation
- ▶ 10.3Gb/s maximum data rate (client side)

Your Partner for Success.

For more information on Vitesse Products visit the Vitesse web site at www.vitesse.com or contact Vitesse Sales at (800) VITESSE or sales@vitesse.com