

Dual Low-Dropout CMOS Voltage Regulator

Features

- Very Low Dropout Voltage
- Guaranteed 150mA for Each Output
- Accurate to Within 1.5% for Both Outputs
- Typical 70 μ A Quiescent Current
- Over-Temperature Shutdown
- Current Limiting
- Noise Reduction Bypass Cap
- Power-Saving Shutdown Mode
- Available in Lead Free, RoHS Compliant Packaging: 6Pin TSOT-26 & 8Pin DFN



**TSOT-26
Top View**

Applications

- Cellular Phones
- Palm / Notebook
- Battery Powered Equipment
- Handheld Devices

General Description

The SP6265 dual, low dropout, linear regulators operate up to 5.5V input and deliver up to 150mA / 150mA output current per regulator. It has a bypass pin option which allows users to decouple the bandgap reference for reducing the output noise. Low dropout voltage and low quiescent current(70 μ A typ.) make them ideal for battery powered applications. The SP6265 is available with a wide variety of standard voltage options and can be trimmed to 1.5% accuracy. For protection purposes, SP6265 has a thermal shutdown feature to prevent device failure under the "worst" operating conditions.

Typical Applications

SP6265 without Bypass

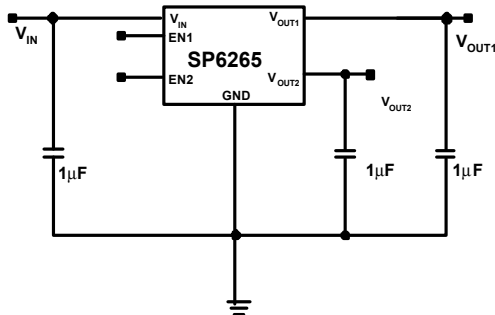

SP6265 with Bypass

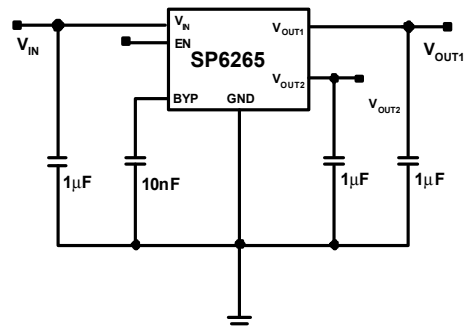

Absolute Maximum Ratings

Parameter	Maximum	Unit
Input Voltage	6	V
Output Current	$P_D / [2V_{IN} - (V_{OUT1} + V_{OUT2})]$	mA
Output Voltage	GND-0.3 to $V_{IN} + 0.3$	V
ESD Classification	C*	

Caution: Stress above the listed absolute maximum rating may cause permanent damage to the device.

* HBM C: 4000V+

Recommended Operating Conditions

Parameter	Symbol	Rating	Unit
Ambient Temperature Range	T_A	-40 to +85	°C
Junction Temperature Range	T_J	-40 to +125	°C

Thermal Information

Parameter	Package	Die Attach	Symbol	Maximum	Unit
Thermal Resistance* (Junction to Case)	TSOT-26	Conductive Epoxy	θ_{JC}	81	°C / W
	DFN-8 (3mmx3mmx0.6mm)			17	
Thermal Resistance (Junction to Ambient)	TSOT-26		θ_{JA}	260	
	DFN-8 (3mmx3mmx0.6mm)			125	
Internal Power Dissipation	TSOT-26		P_D	400	mW
	DFN-8 (3mmx3mmx0.6mm)			800	
Maximum Junction Temperature				150	°C
Solder Iron (10 Sec)**				350	°C

* Measure θ_{JC} on center of molding compound if IC has no tab.

** MIL-STD-202G 210F

Electrical Specifications

Unless specified: $T_J=25^{\circ}\text{C}$, $V_{IN}=\text{Higher } V_{OUT}+1\text{V}$, $I_{OUT1}=I_{OUT2}=1\text{mA}$, $C_{IN}=C_{OUT}=1.0\mu\text{F}$, $V_{EN1}=V_{EN2}=V_{IN}$
 Typical values are at $T_J=25^{\circ}\text{C}$

Parameter	Symbol	Test Condition	Min	Typ	Max	Units	
IN							
Input Supply Voltage	V_{IN}		Note1		5.5	V	
Quiescent Current	I_Q			70	160	μA	
OUT1, OUT2							
Output Voltage	V_O	$I_{OUT}=1\text{mA}$	-1.5	V_{OUT}	1.5	%	
		$0\text{mA}<I_{OUT}<=150\text{mA}$ $V_{OUT}+1\text{V}<V_{IN}<5.5\text{V}$	$T_J = 0^{\circ}\text{C to } +125^{\circ}\text{C}$		-2		2
Line Regulation	REG_{LINE}	$V_{OUT}+1\text{V}<V_{IN}<5.5\text{V}$ $I_{OUT}=1\text{mA}$	$T_J=25^{\circ}\text{C}$	-0.2	0.2	%/V	
			$T_J=-40^{\circ}\text{C to } +125^{\circ}\text{C}$	-0.25	0.25		
Load Regulation	REG_{LOAD}	$1\text{mA}<I_{OUT}$	$T_J = 0^{\circ}\text{C to } +125^{\circ}\text{C}$	-0.005	+0.0025	0.005	%/mA
Dropout Voltage	V_{DROP}	$I_{OUT1}=I_{OUT2}=150\text{mA}$ $V_O=V_{O(NOM)}-2\%$ $V_{O(NOM)}<2.5\text{V}$	$T_J = 0^{\circ}\text{C to } +125^{\circ}\text{C}$		350	mV	
		$I_{OUT1}=I_{OUT2}=150\text{mA}$ $V_O=V_{O(NOM)}-2\%$ $V_{O(NOM)}\geq 2.5\text{V}$			300	mV	
Current Limit	I_{LIM}		180		600	mA	
Short Circuit Current	I_{SC}	Each Channel		200	350		
Ripple Rejection	PSRR	$f=100\text{Hz}$, $C_{BYP}=10\text{nF}$, $I_{OUT}=1\text{mA}$		55		dB	
		$f=1\text{kHz}$, $C_{BYP}=10\text{nF}$, $I_{OUT}=1\text{mA}$		55			
		$f=10\text{kHz}$, $C_{BYP}=10\text{nF}$, $I_{OUT}=1\text{mA}$		48			
Output Voltage Noise	e_n	$f=1\text{kHz to } 100\text{kHz}$ $C_{BYP}=10\text{nF}$, $C_{OUT}=1\mu\text{F}$		550		μVRMS	
		$f=1\text{kHz to } 100\text{kHz}$ $C_{BYP}=10\text{nF}$, $C_{OUT}=1\mu\text{F}$		5.5		$\mu\text{V}/\sqrt{\text{Hz}}$	
EN1, EN2							
Enable Input Threshold	V_{EH}	$V_{IN}=2.4\text{V to } 5.5\text{V}$	$T_J=-40^{\circ}\text{C to } +125^{\circ}\text{C}$	2.4		V	
	V_{EL}	$V_{IN}=2.4\text{V to } 5.5\text{V}$			0.4	V	
EN Input Bias Current	I_{EL}	$V_{IN}=5.0\text{V}$	EN=0V	-1	0.5	1	
	I_{EH}		EN=5V				
Shutdown Current	I_{SHDN}	$V_{IN}=5.0\text{V}$, EN1=EN2=0V		0.3	1		
BYP							
Start-Up Rise Time		$C_{BYP}=10\text{nF}$		1.25		ms	
Over Temperature Protection							
Over Temperature Shutdown	OTS			150		$^{\circ}\text{C}$	
Over Temperature Hysteresis	OTH			20		$^{\circ}\text{C}$	

Note1: $V_{IN(\text{min})} = V_{OUT2} + V_{Dropout}$

Pin Description

SP6265A, B -- TSOT-26 package with Bypass

Pin Number	Pin Name	Description
1	V _{OUT2}	Regulator 2 Output. Sources up to 150mA continuous current. Bypass with a 1 μ F (< 0.5 Ω typ ESR) capacitor to GND.
2	GND	Ground. This pin also functions as heatsink. Solder to a large pad or the circuit-board ground plane to maximize thermal dissipation.
3	BYP	Reference Noise Bypass. Bypass with a low leakage 10nF ceramic capacitor for reduced noise at both outputs.
4	EN	Shutdown control input, active low. Tie this pin to or above 2.4V to enable the device. Tie this pin to or below 0.4V to turn off the device.
5	V _{IN}	Regulator Input. Supply voltage can range from [V _{OUT2} + 1V] to 5.5V. This input also supplies the on-chip reference. Bypass with 1 μ F to GND.
6	V _{OUT1}	Regulator 1 Output. Sources up to 150mA continuous current. Bypass with a 1 μ F (< 0.5 Ω typ ESR) capacitor to GND.

SP6265F, G, H, J, K -- TSOT-26 package without Bypass

Pin Number	Pin Name	Description
1	V _{OUT2}	Regulator 2 Output. Sources up to 150mA continuous current. Bypass with a 1 μ F (< 0.5 Ω typ ESR) capacitor to GND.
2	GND	Ground. This pin also functions as heatsink. Solder to a large pad or the circuit-board ground plane to maximize thermal dissipation.
3	EN1	Shutdown 1 control input, active low. Tie this pin to or above 2.4V to enable the device. Tie this pin to or below 0.4V to turn off the device.
4	EN2	Shutdown 2 control input, active low. Tie this pin to or above 2.4V to enable the device. Tie this pin to or below 0.4V to turn off the device.
5	V _{IN}	Regulator Input. Supply voltage can range from [V _{OUT2} + 1V] to 5.5V. This input also supplies the on-chip reference. Bypass with 1 μ F to GND.
6	V _{OUT1}	Regulator 1 Output. Sources up to 150mA continuous current. Bypass with a 1 μ F (< 0.5 Ω typ ESR) capacitor to GND.

SP6265L, M -- DFN package without Bypass

Pin Number	Pin Name	Description
1	V _{IN}	Regulator Input. Supply voltage can range from [V _{OUT2} +V _{DROPOUT}] to 5.5V. This input also supplies the on-chip reference. Bypass with 1μF to GND.
2	EN1	Shutdown 1 control input, active low. Tie this pin to or above 2.4V to enable the device. Tie this pin to or below 0.4V to turn off the device.
3	EN2	Shutdown 2 control input, active low. Tie this pin to or above 2.4V to enable the device. Tie this pin to or below 0.4V to turn off the device.
4	NC	Not Connected
5	GND	Ground. This pin also functions as heatsink. Solder to a large pad or the circuit-board ground plane to maximize thermal dissipation.
6	NC	Not Connected
7	V _{OUT2}	Regulator 2 Output. Sources up to 150mA continuous current. Bypass with a 1μF (< 0.50Ω typical ESR) capacitor to GND.
8	V _{OUT1}	Regulator 1 Output. Sources up to 150mA continuous current. Bypass with a 1μF (< 0.50Ω typical ESR) capacitor to GND.

Functional Block Diagram

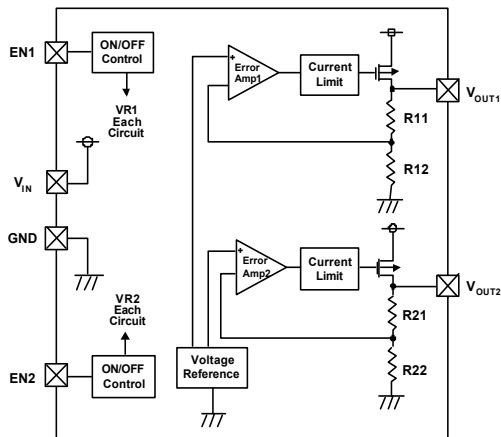

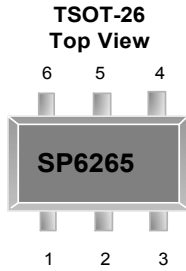

**SP6265AEK1
SP6265BEK1**

1. V_{OUT2}
2. GND
3. BYP
4. EN
5. V_{IN}
6. V_{OUT1}

*** Die Attach:
Conductive Epoxy**

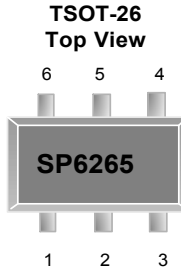

**SP6265FEK1
SP6265GEK1
SP6265HEK1
SP6265JEK1
SP6265KEK1**

1. V_{OUT2}
2. GND
3. EN1
4. EN2
5. V_{IN}
6. V_{OUT1}

*** Die Attach:
Conductive Epoxy**

**DFN-8
(3mmx3mmx0.6mm)
Top View**

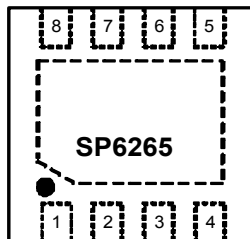

**SP6265LER1
SP6265MER1**

1. V_{IN}
2. EN1
3. EN2
4. NC
5. GND
6. NC
7. V_{OUT2}
8. V_{OUT1}

*** Die Attach:
Conductive Epoxy**

Note:

The area enclosed by dashed line represents the Exposed Pad -- connect to GND.

The SP6265 is low-dropout, low quiescent-current linear regulator designed primarily for battery-powered applications. These parts are available with preset output voltage ranging from 1.8V to 3.3V, and the parts can supply loads up to 150mA.

Shutdown

SP6265A & SP6265B

The SP6265A and SP6265B have a single shutdown control input(EN). Drive EN low to shut down both outputs, reducing supply current to 0.3 μ A. Connect EN to a logic-high, or IN, for normal operation.

SP6265F-SP6265M

The SP6265F-SP6265M have independent shutdown control inputs (EN1 and EN2). Drive EN1 low to shutdown V_{OUT1} . Drive EN2 low to shut down V_{OUT2} . Drive both EN1 and EN2 low to shut down the entire chip, reducing supply current to 0.3 μ A. Connect both EN1 and EN2 to a logic-high, or IN, for normal operation.

Internal P-Channel Pass Transistor

The SP6265 features two 1 Ω P-Channel MOSFET pass transistors. A P-Channel MOSFET provides several advantages over similar designs using PNP pass transistors, including longer battery life. It requires no base drive, which reduces quiescent current significantly. The SP6265 only consumes 70 μ A of quiescent current whether in dropout, light-load, or heavy-load applications.

Current Limit

The SP6265 contains two independent current limiters, one for each regulator, which monitor and control the pass transistor's gate voltage, limiting the guaranteed maximum output current to 180mA minimum. The output can be shorted to ground for an indefinite time without damaging the part.

Thermal-Overload Protection

Thermal -overload protection limits total power dissipation in the SP6265. When the junction temperature exceeds $T_j=150^{\circ}\text{C}$, the thermal sensor signals the shutdown logic, turning off the pass transistor and allowing the IC to cool.

Application Information

Capacitor Selection and Regulator Stability

Use a 1 μ F capacitor on the SP6265 input and a 1 μ F capacitor on the outputs. Larger input capacitor values and lower ESRs provide better supply noise rejection and line transient response.

PSRR and Operation from Sources Other than Batteries

The SP6265 is designed to deliver low dropout voltages and low quiescent current in battery powered systems. Power-supply rejection is 54dB at low frequencies. (See the PSRR vs. Frequency graph)

Quiescent Current vs Input Voltage

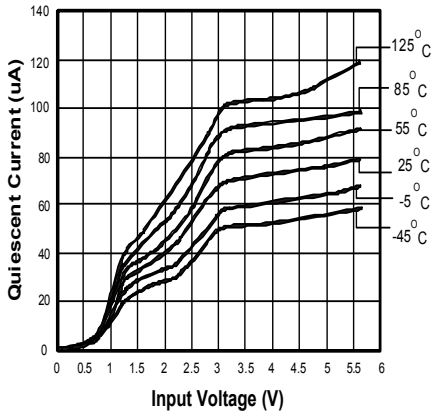

Dropout Voltage vs Load Current

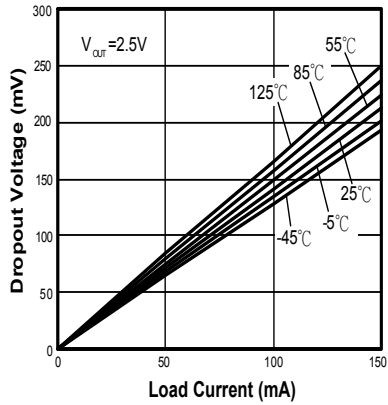

Supply Current vs. Load current

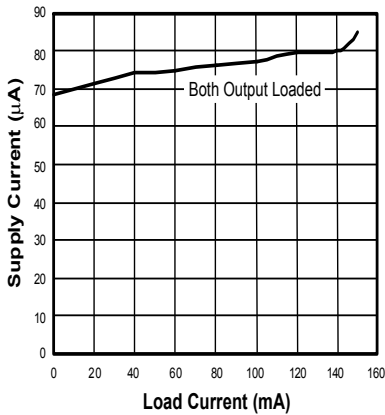

Dropout Voltage vs Output Voltage

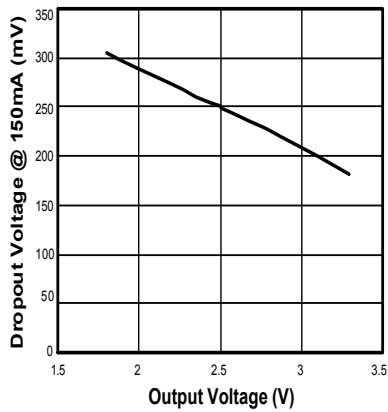

Quiescent Current vs Temperature

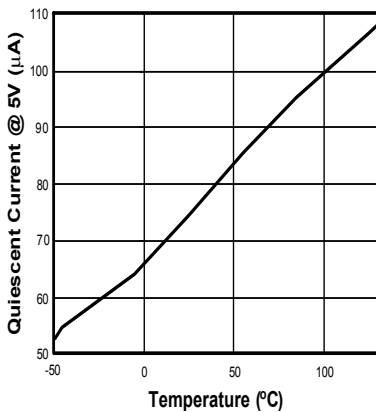

Output Voltage vs Temperature

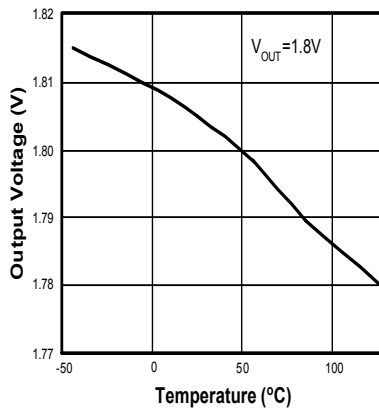

PSRR vs. Frequency

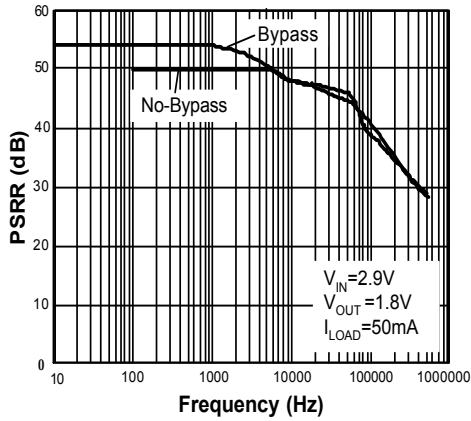

Line Transient

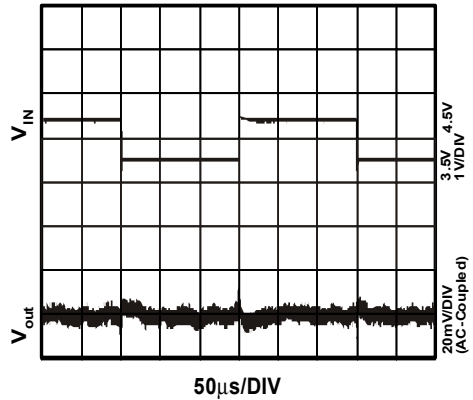

Channel-to-Channel Isolation vs Frequency

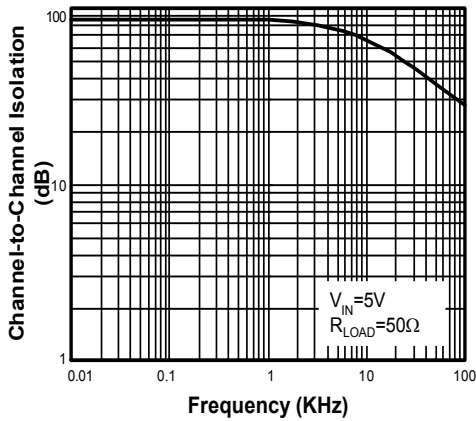

Load Transient

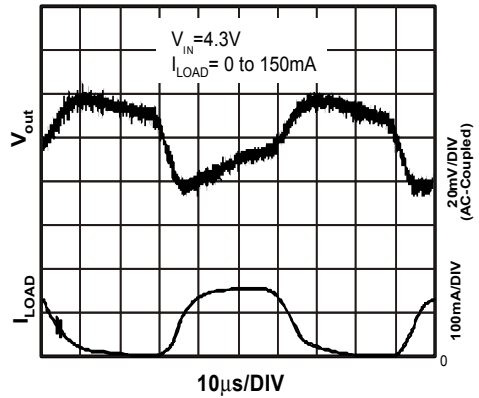

Output Noise Spectral Density

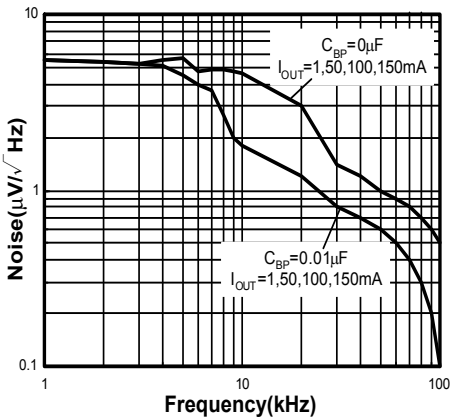

Load Transient Near Dropout

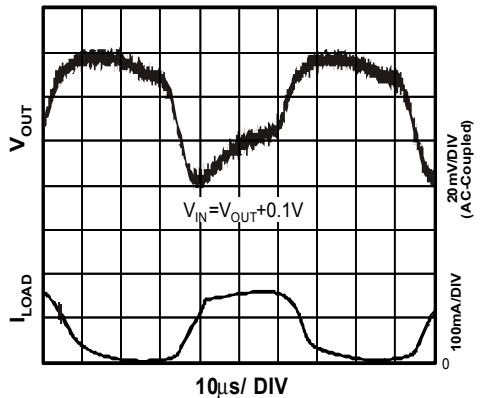

Shutdown Response

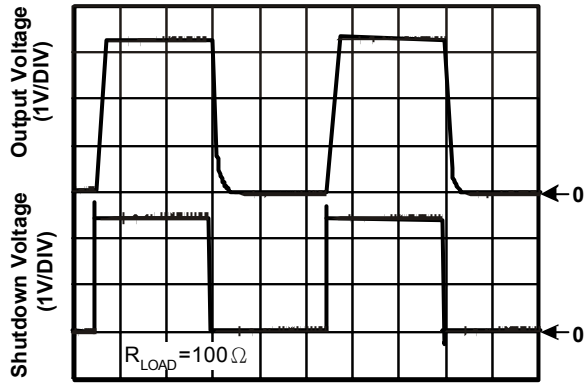

• Package Dimensions

TSOT-26

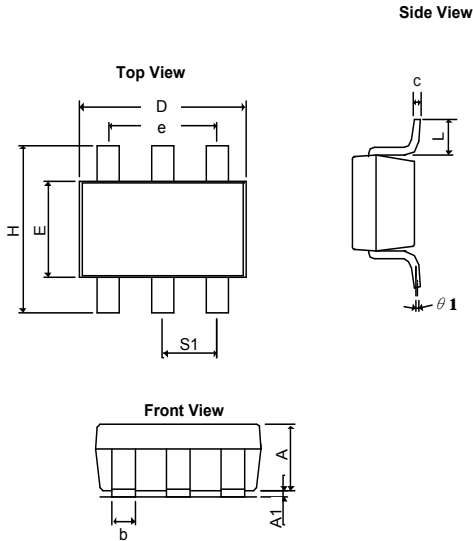

SYMBOLS	MILLIMETERS		INCHES	
	MIN	MAX	MIN	MAX
A+A₁	0.90	1.25	0.0354	0.0492
b	0.30	0.50	0.0118	0.0197
c	0.09	0.25	0.0035	0.0098
D	2.70	3.10	0.1063	0.1220
E	1.40	1.80	0.0551	0.0709
e	1.90 BSC		0.07480 BSC	
H	2.40	3.00	0.09449	0.11811
L	0.35BSC		0.0138BSC	
$\theta 1$	0°	10°	0°	10°
S₁	0.95BSC		0.0374BSC	

• Package Dimensions

DFN-8 (3mmx3mmx0.6mm)

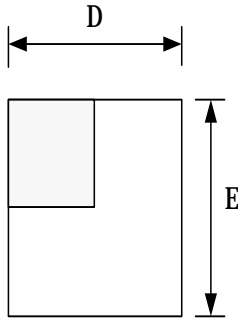

TOP VIEW

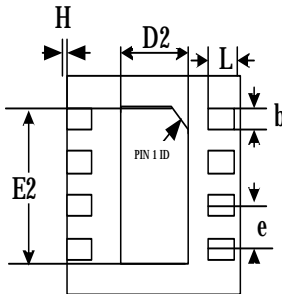

BOTTOM VIEW

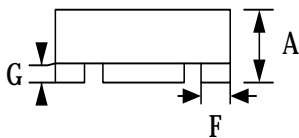

SIDE VIEW

SYMBOLS	MILLIMETERS		INCHES	
	MIN	MAX	MIN	MAX
A	0.550	0.650	0.022	0.026
D	2.900	3.100	0.114	0.122
E	2.900	3.100	0.114	0.122
F	0.550 TYP.		0.220 TYP.	
e	0.650 TYP.		0.026 TYP.	
D2	1.500 TYP.		0.059 TYP.	
E2	2.400 TYP.		0.094 TYP.	
b	0.200	0.300	0.0079	0.012
L	0.450	0.550	0.018	0.022
G	0.010	0.090	0.0004	0.004
H	0.000	0.050	0.000	0.002

Part Number	Voltage	Pin3/ Pin4 Trait	Voltage Accuracy	Operating Temperature Range	Package	Marking*	Packing Quantity
SP6265AEK1-L/TR	V1=1.8V V2=2.5V	Bypass/ Enable	1.5%	-40°C to +85°C	TSOT-26	X9WW	3,000 Tape & Reel
SP6265BEK1-L/TR	V1=1.8V V2=2.8V	Bypass/ Enable	1.5%	-40°C to +85°C	TSOT-26	Y9WW	3,000 Tape & Reel
SP6265FEK1-L/TR	V1=1.8V V2=2.5V	Dual Enable	1.5%	-40°C to +85°C	TSOT-26	DAWW	3,000 Tape & Reel
SP6265GEK1-L/TR	V1=1.8V V2=2.8V	Dual Enable	1.5%	-40°C to +85°C	TSOT-26	EAWW	3,000 Tape & Reel
SP6265HEK1-L/TR	V1=1.8V V2=3.3V	Dual Enable	1.5%	-40°C to +85°C	TSOT-26	FAWW	3,000 Tape & Reel
SP6265JEK1-L/TR	V1=2.85V V2=2.85V	Dual Enable	1.5%	-40°C to +85°C	TSOT-26	GAWW	3,000 Tape & Reel
SP6265KEK1-L/TR	V1=3.0V V2=3.0V	Dual Enable	1.5%	-40°C to +85°C	TSOT-26	HAWW	3,000 Tape & Reel
SP6265LER-L/TR	V1=1.8V V2=2.5V	Dual Enable	1.5%	-40°C to +85°C	DFN8	6265LEWWX	1,000 Tape & Reel
SP6265MER-L/TR	V1=1.8V V2=2.8V	Dual Enable	1.5%	-40°C to +85°C	DFN8	6265MEWWX	1,000 Tape & Reel

*Note: "WW" = Product Work Week, "X" = 1st Alpha of Lot Number



Sipex Corporation

**Headquarters and
Sales Office**

233 South Hillview Drive
Milpitas, CA 95035
TEL: (408) 934-7500
FAX: (408) 935-7600

Sipex Corporation reserves the right to make changes to any products described herein. Sipex does not assume any liability arising out of the application or use of any product or circuit described herein; neither does it convey any license under its patent rights nor the rights of others.