

**CONSTANT-CURRENT CHOPPER DRIVE UPS
STEPPER-MOTOR PERFORMANCE**

The most efficient and performant way to drive a stepper motor is to use a "chopper" drive circuit. This note explains some basic theory then presents practical circuits based on power ICs.

PULSE WIDTH-MODULATED DRIVE IMPROVES MOTOR TORQUE AND SPEED YET ADDS NO COMPLEXITY TO CIRCUIT

Designers opting to use a fractional-horsepower stepper motor in applications such as computer printers can improve the motor's efficiency and its torque and speed characteristics by using a constant-current pulse-width-modulated (PWM) chopper-drive circuit. What's more, for high-power drives, dedicated control chips and a constant-current chopper drive can be as simple to use as direct drive.

A basic problem for a directly driven stepper is that the motor winding's time constant (L/R) causes the current to increase slowly in the winding during each pulsed input. It may, therefore, never reach full-rated value, especially at high speed, or high pulsing rates, unless the voltage (V_s) across the terminals is

high. In the simplest stepper drive (see fig. 1a), transistor or Darlington switches sequentially activate the windings to drive the motor (see box, "Stepper motor basics").

This type of drive performs poorly because the supply voltage must be low so that the steady-state current is not excessive. As a result, the average winding current – and hence the torque – is very low at high drive motor speed.

Often, this problem is overcome by introducing a series resistance, thereby increasing the overall value by a factor of four - giving an $L/4R$ ratio - and also by increasing the supply voltage (see fig. 1b). This arrangement reduces the motor's time constant, which improves torque at high step rates. However such an approach is inefficient, because the series resistor constitutes a substantial waste of power.

Figure 1 : Common unipolar stepping drives (a) produce insufficient torque output because their supply voltage must be kept low to limit current. Adding series resistance to an $L/4R$ ratio (b) and raising the supply voltage proportionately improves torque output, especially at high step rates.

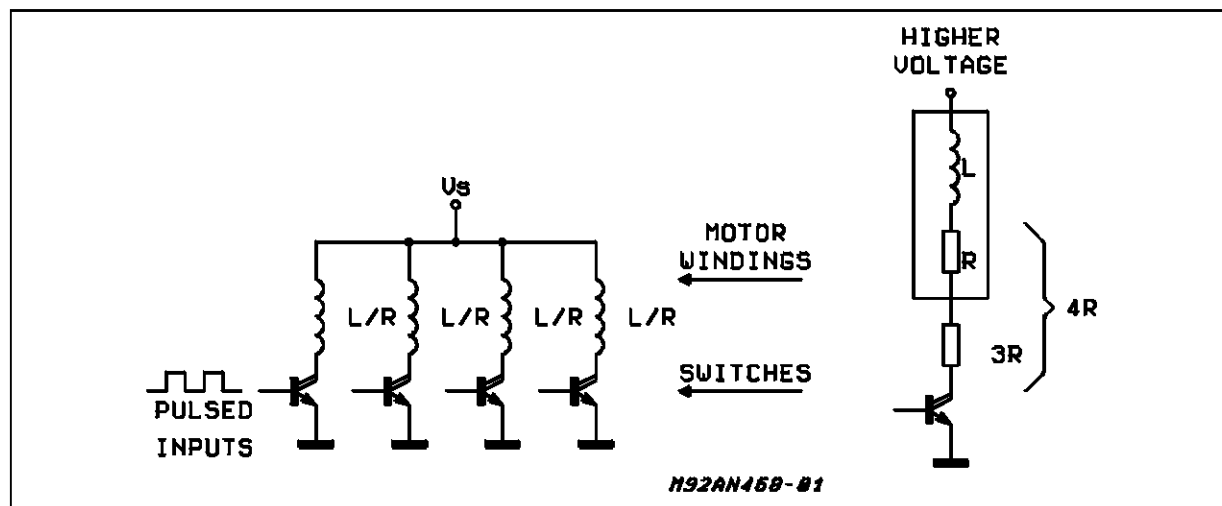

APPLICATION NOTE

Figure 2 : A Pulse-width-modulated, or chopper, drive overcomes most of the problems of the simpler direct drive or even linear constant-current drives.

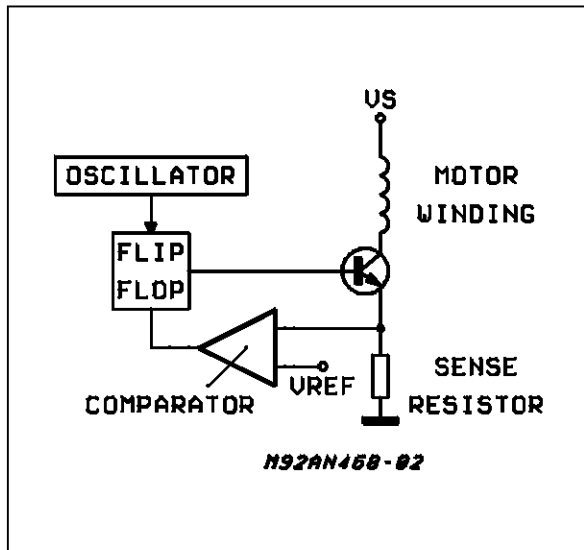

CONSTANT CURRENT IS BEST

Introducing a feedback loop to control the winding current is a better solution. Linear constant-current control is possible but is rarely used because of high power losses in the power stage. However, a pulse-width-modulation scheme – a chopper circuit – not

only solves the L/R time-constant problem but cuts power dissipation too (see fig. 2).

A four-phase bifilar/hybrid unipolar stepper motor could use a quad Darlington like the ULN2075B as a chopper driver and a chip like the L6506 as a current controller (see fig. 3).

The L6506, which contains all the chopper circuitry, is simple to use. An external RC network sets the oscillator frequency, and a voltage divider (or trimmer) sets the reference voltages, and hence the phase currents. Normally an oscillator frequency of over 20 KHz is chosen to avoid motor noise. The maximum usable frequency depends on the L/R time constant of the motor.

Control signals for the four-phase inputs can be provided by a micro-computer chip or a simple repetitive sequence from a logic circuit. Note that the L6506 contains just two independent chopper-control loops - sufficient for a four-phase unipolar stepping motor because opposing windings never energize together.

DRIVING BIPOLAR MOTORS

Bipolar stepper motors, preferred for their better torque/weight ratio, however, are normally driven by H-bridge output stages. They enable a single-polarity supply to drive each motor winding end sequentially to achieve a polarity-reversal effect on the windings.

Figure 3 : A simple chopper drive for a unipolar stepping motor, can be assembled with just two chips : a Quad Darlington output driver IC and constant-current feedback controller IC.

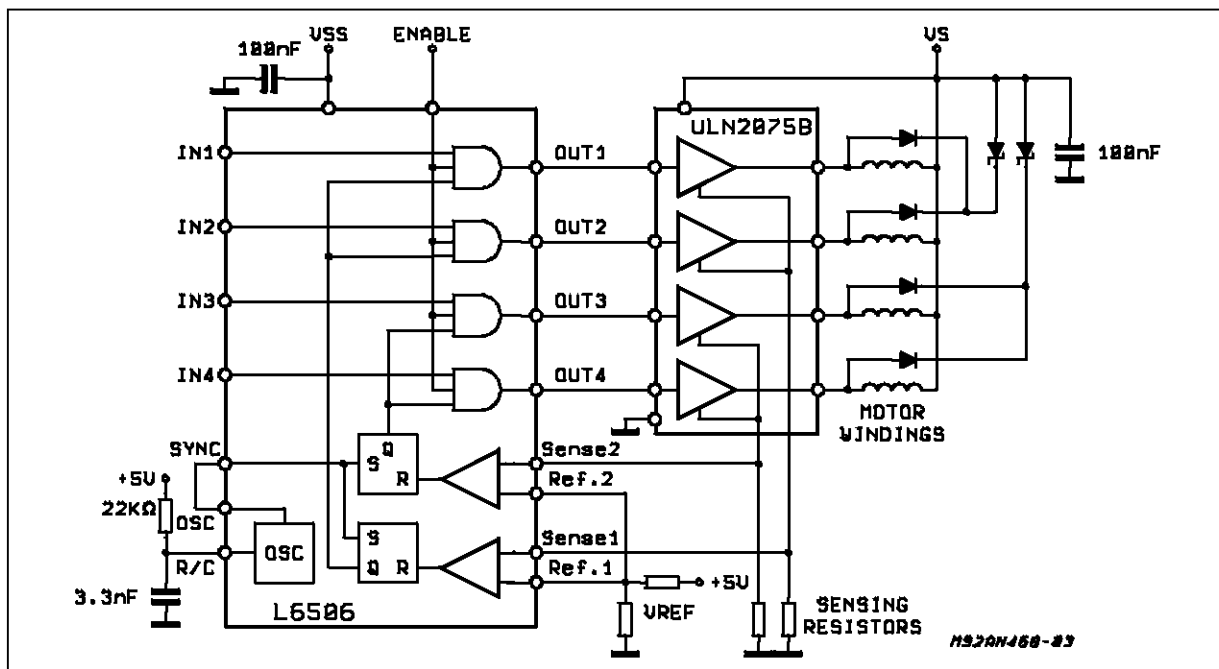

STEPPER-MOTOR BASICS

In computer-peripheral office-equipment applications, the most popular stepper motors are permanent-magnet types with two-phase bipolar windings or bifilar-wound unipolar windings. Stripped to the essentials, both types consist of a permanent-magnet rotor surrounded by stator poles carrying the windings.

A two-pole motor would have a step angle of 90°. However, most motors have multiple poles to reduce the step angle to a few degrees.

A bipolar permanent-magnet stepper motor has a single winding for each phase – and the current must be reversed to reverse the stator field. Bifilar/hybrid unipolar motors, however, have two windings wound in opposite directions for each phase, so that the field can be reversed with a single-polarity drive. Unipolar motors were once popular because the drive was simpler. But with today's dual bridge (H-bridge) ICs, it is just as easy to drive a bipolar motor.

In the most popular drive technique - two-phase-on - both phases are always energized. In another method – called the wave drive – one phase is energized at a time.

A third technique combines the two sequences and drives the motor one half-step at a time. Half-stepping is very useful because motor mechanically designed for very small step angles are much more complex – and costly – to built. It is more economical to use a 100-step motor in half steps rather than a 200-step motor in full step.

Recently designers have started microstepping, or driving the motor at one-quarter stepping rather or less. This type of operation can obtain fine step control without using mechanically complex motors with small step angles.

A two-phase bipolar motor needing up to 2A/phase can be driven by a single IC - the L298N dual bridge (see fig. 4). It contains two H-bridges with all the necessary level shifters and gates to directly interface low-level input logic signals.

As before, a complete chopper drive can be built by adding a current-controller chip and the necessary protective diodes, an RC network to define the oscillator frequency and a reference-voltage divider to set the current level. Four-phase signals to the controller are provided by a controlling microcomputer or by another dedicated controller chip - the L297 stepper-motor controller.

Figure 4 : A Dual-bridge IC provides a simple power-stage design solution for a bipolar stepper motor.

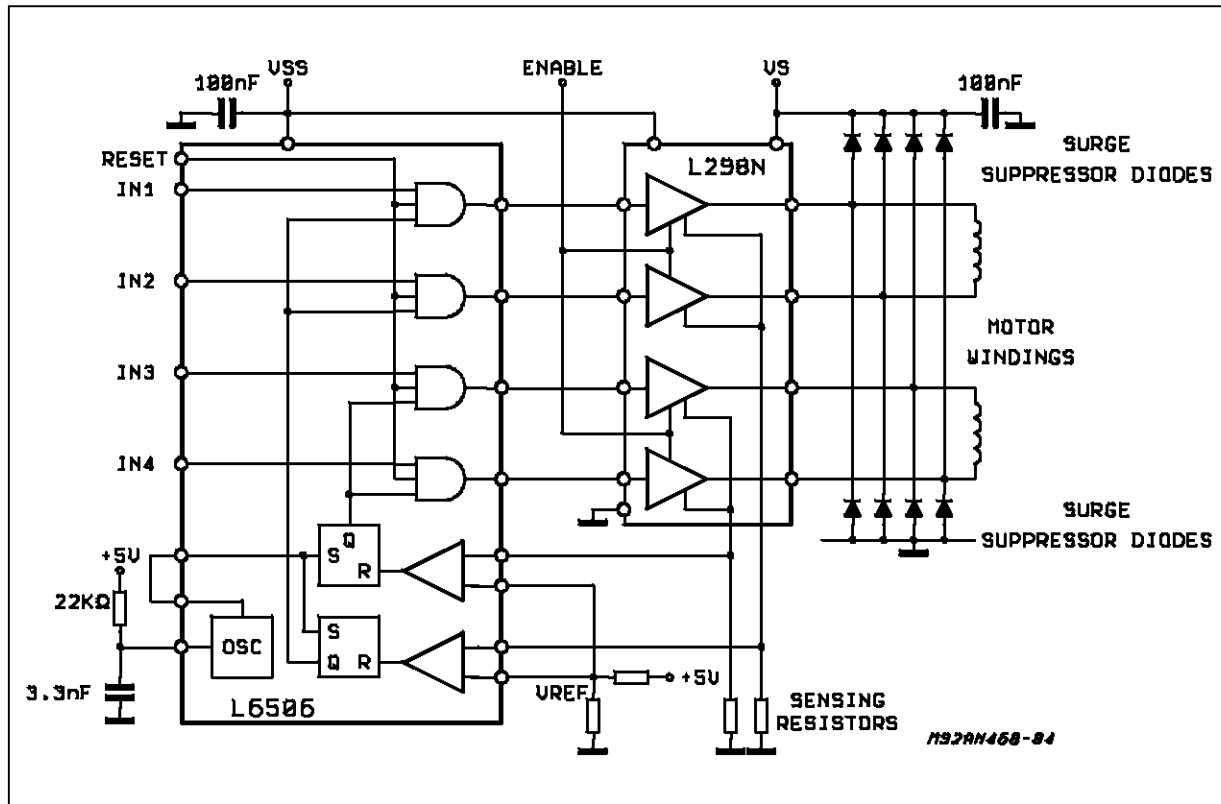

APPLICATION NOTE

Containing an internal translator circuit controlled by step-and-direction inputs, the L297 motor controller (see fig. 5) allows operation in three modes : two-phase-on, half-step and wave-drive.

The normal two-phase-on mode is selected by a low level on the half/full input when the device has been reset to start.

Half-step drive is selected by a high level on the half/full step input. To initialize the wave-drive mode, the user disables the output stage (brings enable low), resets the device, steps the translator one step, brings half/full low, and then reenables the outputs.

The L297 also lets the designer select either phase or inhibit chopping. Phase chopping provides lower

ripple and is suitable for unipolar motor, whereas inhibit chopping returns energy to the supply and is better for bipolar motors.

In applications such as printer-paperfeed, the motor is often at rest. Since the full torque is not usually necessary to hold the motor in position, designers can save power by switching the current to a lower level between runs. With an L297 or L6506 control chip, this task can be done by simply switching the reference input between two levels.

Where several chopper drives are used in the same system, they should be synchronized to prevent inter-modulation effects. This is done by connecting the sync pins to one another and omitting the oscillator RC network on all but one device.

Figure 5 : controlled by step, direction, and mode inputs, the L297 stepper-motor controller chip performs some of the functions of a controlling microcomputer.

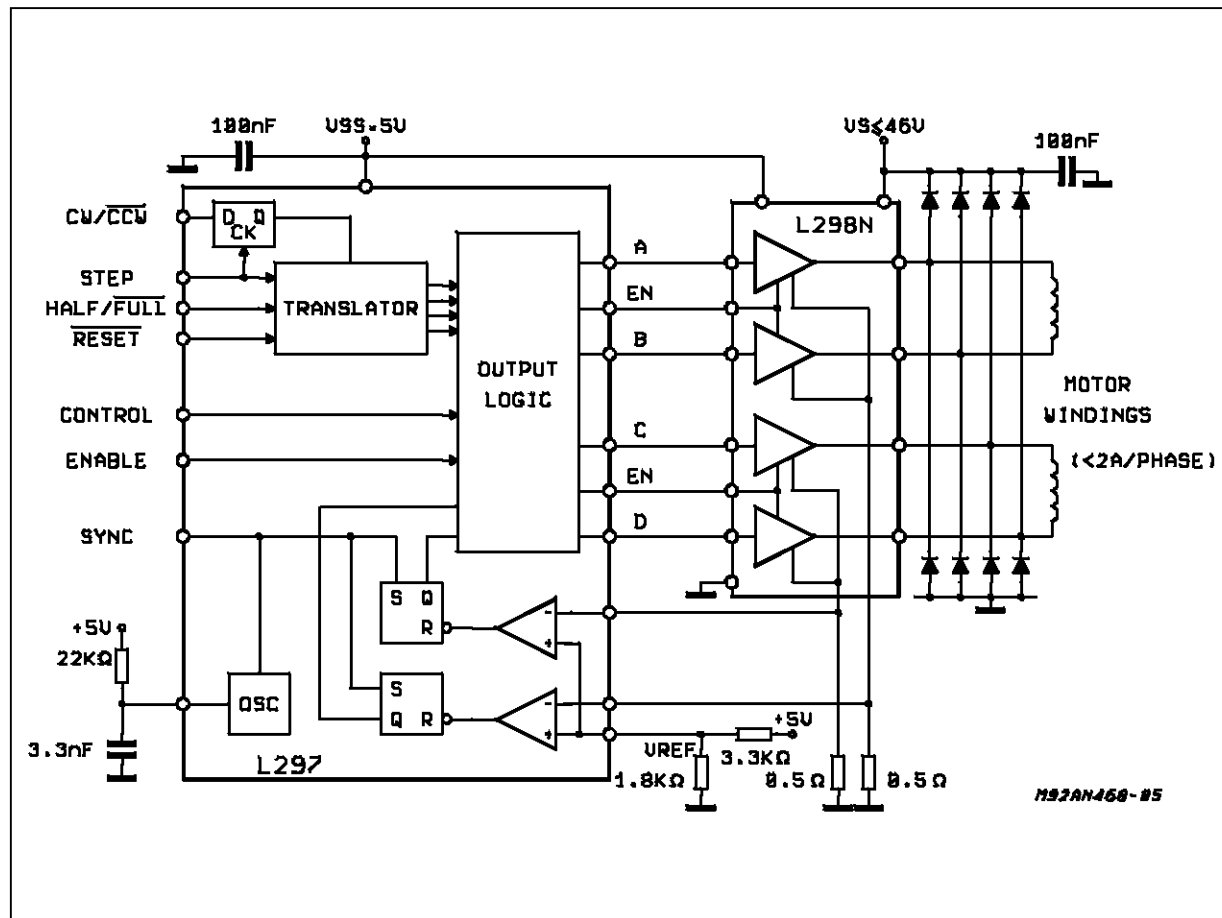

HANDLING HIGH CURRENT

For current drives greater than 2A/phase, the two bridges in an L298N IC can be paralleled by connecting inputs to the corresponding outputs. However, for a more equal distribution of the load and chip heating, driver 1 should be paralleled with driver 4, and driver 2 with driver 3. Additionally, total current should be derated by 0.5 A to allow for the maximum possible imbalance between the current in each bridge. Thus two L298s can drive motors rated at 3.5 A/phase.

A different configuration for microstepping stepper motors is employed in the PBL3717A control circuit. It contains all of the control and power circuitry for

one phase of a motor. An H-bridge output stage can drive motors rated at up to 1A/phase. Two of these devices are needed to drive a two-phase bipolar motor.

The output current level from the PBL3717A is set both by an analog-reference input and two logic inputs (I_1 and I_0), which select one of three preset current levels (the fourth combination disables the outputs stage). This feature implements the microstepping, in which several current levels are used to obtain very small step angles for even more precise control (but at the expense of a less regular torque). Unlike the L297 and L6506, the PBL3717A has a constant off-time chopper driver which is ideal for microstepping.

APPLICATION NOTE

Information furnished is believed to be accurate and reliable. However, SGS-THOMSON Microelectronics assumes no responsibility for the consequences of use of such information nor for any infringement of patents or other rights of third parties which may result from its use. No license is granted by implication or otherwise under any patent or patent rights of SGS-THOMSON Microelectronics. Specifications mentioned in this publication are subject to change without notice. This publication supersedes and replaces all information previously supplied. SGS-THOMSON Microelectronics products are not authorized for use as critical components in life support devices or systems without express written approval of SGS-THOMSON Microelectronics.

© 1995 SGS-THOMSON Microelectronics - All Rights Reserved

SGS-THOMSON Microelectronics GROUP OF COMPANIES

Australia - Brazil - France - Germany - Hong Kong - Italy - Japan - Korea - Malaysia - Malta - Morocco - The Netherlands - Singapore - Spain - Sweden - Switzerland - Taiwan - Thailand - United Kingdom - U.S.A.