

## MT2050 SINGLE-CHIP BROADBAND TUNER

## CABLE MODEM TUNER AND DIGITAL SET-TOP BOX APPLICATIONS

### APPLICATIONS

- Cable modems / voice-enabled cable modems
- Digital set-top boxes (STB)
- Home gateways

### FEATURES

- 48 MHz to 860 MHz input frequency range
- Works seamlessly with all analog and digital demodulators
- Low power dual-conversion architecture
- Minimal external components
- No manually tunable parts required
- Simple interface to external filters
- Integrated IF variable gain amplifier for direct connection to digital demodulators
- Fully compatible with NTSC, PAL, SECAM, DAVIC, DVB-C, DOCSIS 1.0, 1.1 and 2.0, EuroDOCSIS and other standards



MT2050 Tuner

The MT2050 is an advanced single-chip broadband tuner that has been optimized for high performance cable modems and digital cable STBs that require low composite distortion and noise under digital cable environments. The MT2050 includes all active circuitry required to implement total RF functionality, making it the world's first complete RF/amplifier silicon front end. It is capable of receiving frequencies in the 48 MHz to 860 MHz range and converting a selected channel to a standard intermediate frequency (IF). Supported IF frequencies include

NTSC, PAL, and digital standards including DOCSIS, EuroDOCSIS, DVB-C, and ITU J83, A, B, C.

The MT2050's low close-in phase noise allows it to be used for both digital and analog video signals including video, high speed data, and voice. Its dual-conversion architecture, with no requirement for tracking filters, yields the desirable characteristics of traditional cable television tuners: controlled input impedance across the entire input band, low in-band emissions, and outstanding image rejection.



PIN DIAGRAM

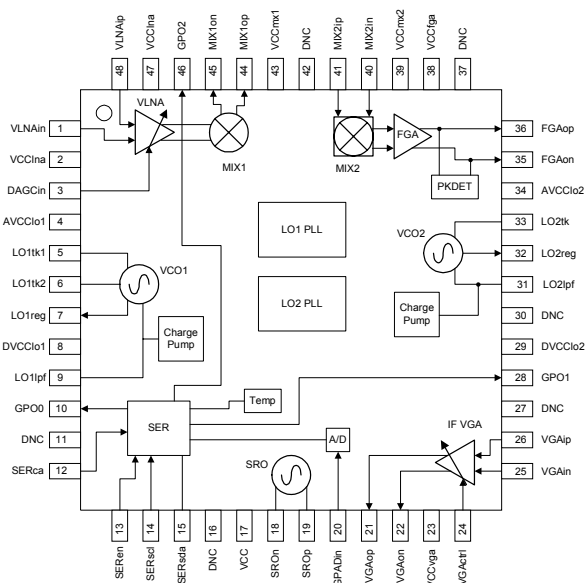

ELECTRICAL CHARACTERISTICS

PARAMETER	MIN	TYP	MAX	UNIT
<b>Power Supply</b>				
Active current		325		mA
Shut-down current		40		mA
<b>Upconversion</b>				
Input frequency range	48		860	MHz
Return loss		9.5		dB
First IF center frequency		1220		MHz
Noise figure, max gain		7		dB
Terminal voltage gain		18		dB
AGC range	30			dB
Gain variation at any frequency	-3		+3	dB
OIP3	68	72		dBmV
<b>Downconversion</b>				
Input frequency range		1220		MHz
Noise figure		10		dB
Terminal voltage gain		29		dB
Image rejection	28	33		dBc
OIP3	77	79		dBmV
<b>LO1</b>				
LO frequency	1268		2080	MHz
LO step size		1		kHz
Phase noise (10 kHz)		-86		dBc/Hz
Phase noise (100 kHz)		-109		dBc/Hz
Spurious			-60	dBc
<b>LO2</b>				
LO frequency	1160		1190	MHz
LO step size		50		kHz
Phase noise (10 kHz)		-94		dBc/Hz
Phase noise (100 kHz)		-114		dBc/Hz
Spurious			-60	dBc
<b>IF VGA</b>				
Frequency range	30		60	MHz
Output voltage		1.0		Vp-p
Terminal voltage gain	12.5		51.5	dB
Noise figure, max gain		12.5		dB
OIP3	76			dBmV
<b>Serial Interface</b>				
Serial clock frequency			400	kHz
V <sub>IH</sub>	2.3			V
V <sub>IL</sub>			1.5	V

RECOMMENDED OPERATING CONDITIONS

PARAMETER	MIN	TYP	MAX	UNIT
Input frequency range	48		860	MHz
First intermediate center frequency		1220		MHz
Second intermediate center frequency (programmable)	30		60	MHz
Supply voltage	4.75	5	5.25	V
Supply voltage ripple			15	mV
Operating junction temperature			100	°C
VGA output load impedance	300			Ω
Serial control clock			400	kHz

ABSOLUTE MAXIMUM RATINGS

PARAMETER	MIN	MAX	UNIT
Supply voltage		6	V
Storage temperature range	-40	+150	°C
Lead temperature (soldering, 4 seconds)		+245	°C
Input voltage	-0.3	VCC +0.3	V

Worldwide Headquarters • Microtune, Inc., 2201 Tenth Street, Plano, TX 75074, USA • Tel: +1-972-673-1600, Fax: +1-972-673-1602, E-mail: sales@microtune.com, Web site: [www.microtune.com](http://www.microtune.com)

For a detailed list of design centers, sales offices, and sales representatives, visit our Web site at [www.microtune.com](http://www.microtune.com).

The information in this document is believed to be accurate and reliable. Microtune assumes no responsibility for any consequences arising from the use of this information, nor from any infringement of patents or the rights of third parties which may result from its use. No license is granted by implication or otherwise under any patent or other rights of Microtune. The information in this publication replaces and supersedes all information previously supplied, and is subject to change without notice. The customer is responsible for assuring that proper design and operating safeguards are observed to minimize inherent and procedural hazards. Microtune assumes no responsibility for applications assistance or customer product design.

The devices described in this document are not authorized for use in medical, life-support equipment, or any other application involving a potential risk of severe property or environmental damage, personal injury, or death without prior express written approval of Microtune. Any such use is understood to be entirely at the user's risk.

Microtune, MicroTuner, MicroStreamer, VideoCaster, and the Microtune logo are trademarks of Microtune, Inc. All other trademarks belong to their respective companies.

Microtune's products are protected by one or more of the following U.S. patents: 5,625,325; 5,648,744; 5,717,730; 5,737,035; 5,739,730; 5,805,988; 5,847,612; 6,100,761; 6,104,242; 6,144,402; 6,163,684; 6,169,569; 6,177,964; 6,218,899 and additional patents pending or filed.

Entire contents Copyright © 2002 Microtune, Inc.

