

**Main Features**

- Ultra-miniature design, extremely light weight
- Contact capacity from 1mA to 1A
- PCB terminal layout meets 2.54 grid
- UL, CSA approvals
- Ideal for hand carrying equipment

Typical Applications

- Telecom equipment
- Computer peripherals

Ordering InformationYH507 /

--	--	--	--

1. Coil Voltage Code

Please refer to the Coil Voltage Code in Coil Data section

2. Contact Form

Z: 1 Form C

3. Version

1: Sealed

4. Contact MaterialNone : Ag
A: Au plated Ag**Coil Data**

Coil Voltage Code	Nominal Voltage (VDC)	Resistance (Ω) $\pm 10\%$	Power Consumption	Must Operate Voltage Max. (VDC)	Must Release Voltage Min. (VDC)
003	3	60	0.15W	2.4	0.3
005	5	167		4.0	0.5
006	6	240		4.8	0.6
009	9	540		7.2	0.9
012	12	960		9.6	1.2
024	24	3,840		19.2	2.4

Contact Rating

Form	1 Form C (Z)
Rated Load	0.5A, 125VAC; 1A, 24VDC
Max. Continuous Current	2A
Max. Switching Voltage	125VAC/60VDC
Max. Switching Current	1A
Max. Switching Power	62.5VA/30W
Min. Load	1mA, 5VDC

UL / CSA Rating

Form	1 Form C (Z)
Resistive	1A, 30VDC 0.3A, 60VDC
General Use	0.5A, 125VAC

Contact Data

Material	Ag; Au plated Ag	
Initial Contact Resistance	100m Ω , max. at 0.1A, 6VDC	
Service Life	Mechanical	5 x 10 ⁶ ops.
	Electrical	10 ⁵ ops.

Characteristics

Operate Time	5ms. max.
Release Time	5ms. max.
Insulation Resistance	Between coil and contacts: 1,000M Ω , at 500VDC, 50%RH Between open contacts: 1,000M Ω , at 250VDC, 50%RH
Dielectric Strength	Between coil and contacts: 1,000Vrms, 1Min. Between open contacts: 400Vrms, 1Min.
Surge Resistance	1,500V (FCC Part 68 compliant)
Shock Resistance	Functional : 10g, 11ms.; Destructive : 100g
Vibration Resistance	DA 3.3mm, 10-55 Hz
Power Consumption	0.15W
Ambient Temperature	Operating and storage : -40°C to 70°C
Weight	2.2g approx.

Overall Dimensions (mm)

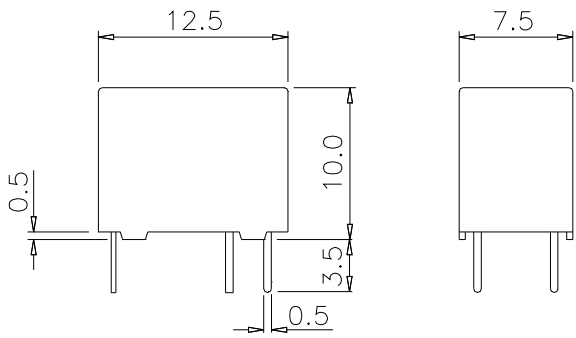

Mounting Holes (Bottom View) (mm)

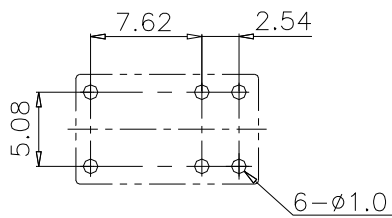

Wiring Diagram (Bottom View)

1 Form C (Z)

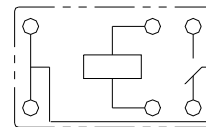

Reference Curves

Ambient Temp. vs. Max. Coil Voltage

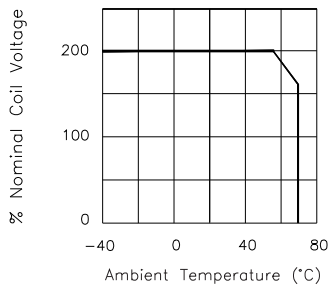

Life Expectancy

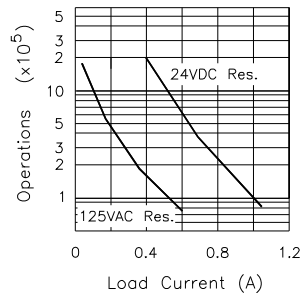

Note: 1. All parameters, unless otherwise specified, are measured at ambient temperature 23°C .