

## 16 Mbit (1Mb x16) 3V Supply FlexibleROM™ Memory

### FEATURES SUMMARY

- ONE TIME PROGRAMMABLE
- SUPPLY VOLTAGE
  - $V_{CC} = 2.7$  to  $3.6V$  for Read
  - $V_{PP} = 11.4$  to  $12.6V$  for Program
- ACCESS TIME
  - $90ns$  at  $V_{CC} = 3.0$  to  $3.6V$
  - $100, 110ns$  at  $V_{CC} = 2.7$  to  $3.6V$
- PROGRAMMING TIME
  - $9\mu s$  per Word typical
  - Multiple Word Programming Option  
( $2s$  typical Chip Program)
- SUITABLE FOR ON-BOARD PROGRAMMING
- PROGRAM CONTROLLER
  - Embedded Word Program algorithms
- ELECTRONIC SIGNATURE
  - Manufacturer Code:  $0020h$
  - Device Code :  $888Dh$

Figure 1. Packages

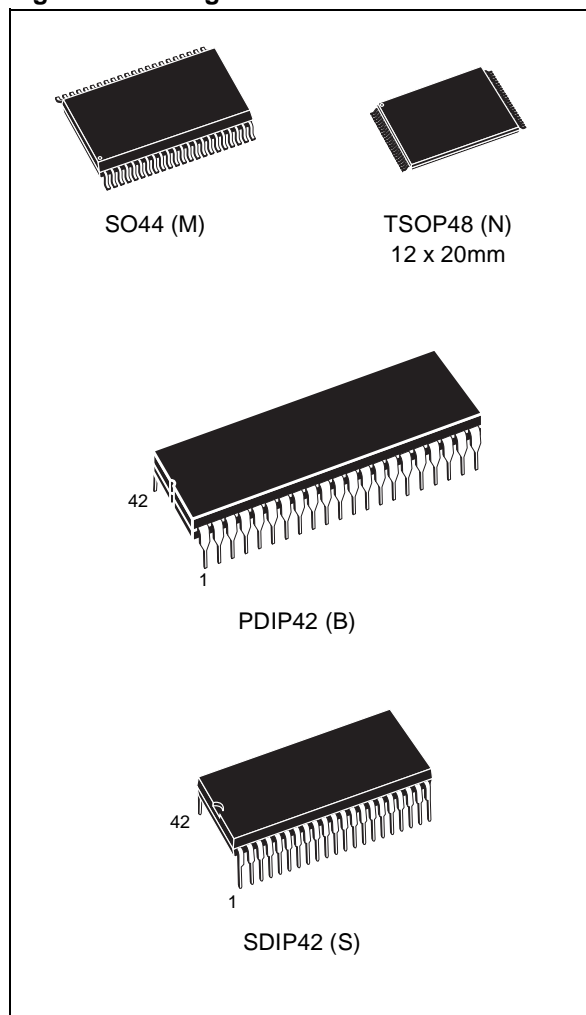

## TABLE OF CONTENTS

<b>FEATURES SUMMARY</b> .....	<b>1</b>
Figure 1. Packages .....	1
Figure 2. Logic Diagram .....	4
Table 1. Signal Names .....	4
Figure 3. PDIP Connections .....	5
Figure 4. SDIP Connections .....	5
Figure 5. SO Connections .....	6
Figure 6. TSOP Connections .....	6
<b>SIGNAL DESCRIPTIONS</b> .....	<b>7</b>
Address Inputs (A0-A19) .....	7
Data Inputs/Outputs (DQ0-DQ7) .....	7
Data Inputs/Outputs (DQ8-DQ15) .....	7
Chip Enable (E) .....	7
Output Enable (G) .....	7
V <sub>CC</sub> Supply Voltage .....	7
V <sub>PP</sub> Program Supply Voltage .....	7
V <sub>SS</sub> Ground .....	7
<b>BUS OPERATIONS</b> .....	<b>8</b>
Bus Read .....	8
Bus Write .....	8
Output Disable .....	8
Standby .....	8
Automatic Standby .....	8
Electronic Signature .....	8
Table 2. Bus Operations .....	8
<b>COMMAND INTERFACE</b> .....	<b>9</b>
Read/Reset Command .....	9
Auto Select Command .....	9
Word Program Command .....	9
Multiple Word Program Command .....	9
Setup Phase .....	9
Program Phase .....	9
Verify Phase .....	10
Exit Phase .....	10
Table 3. Standard Commands .....	11
Table 4. Multiple Word Program Command .....	11
Table 5. Program Times .....	11
Figure 7. Multiple Word Program Flowchart .....	12

<b>STATUS REGISTER</b> .....	<b>13</b>
Data Polling Bit (DQ7) .....	13
Toggle Bit (DQ6) .....	13
Error Bit (DQ5) .....	13
V <sub>PP</sub> Status Bit (DQ4) .....	13
Multiple Word Program Bit (DQ0) .....	13
Multiple Word Program Bit (DQ0) .....	13
Table 6. Status Register Bits .....	14
Figure 8. Data Polling Flowchart .....	14
Figure 9. Data Toggle Flowchart .....	14
<b>MAXIMUM RATING</b> .....	<b>15</b>
Table 7. Absolute Maximum Ratings .....	15
<b>DC and AC PARAMETERS</b> .....	<b>16</b>
Table 8. Operating and AC Measurement Conditions .....	16
Figure 10. AC Measurement I/O Waveform .....	16
Figure 11. AC Measurement Load Circuit .....	16
Table 9. Device Capacitance .....	16
Table 10. DC Characteristics .....	17
Figure 12. Read AC Waveforms .....	18
Table 11. Read AC Characteristics .....	18
Figure 13. Chip Enable Controlled, Write AC Waveforms .....	19
Table 12. Chip Enable Controlled, Write AC Characteristics .....	19
<b>PACKAGE MECHANICAL</b> .....	<b>20</b>
SO44 - 44 lead Plastic Small Outline, 500 mils body width, Package Outline .....	20
SO44 - 44 lead Plastic Small Outline, 500 mils body width, Package Mechanical Data .....	20
TSOP48 - 48 lead Plastic Thin Small Outline, 12 x 20mm, Package Outline .....	21
TSOP48 - 48 lead Plastic Thin Small Outline, 12 x 20mm, Package Mechanical Data .....	21
PDIP42 - 42 pin Plastic DIP, 600 mils width, Bottom View Package Outline .....	22
PDIP42 - 42 pin Plastic DIP, 600 mils width, Package Mechanical Data .....	22
SDIP42 - 42 pin Shrink Plastic DIP, 600 mils width, Package Outline .....	23
SDIP42 - 42 pin Shrink Plastic DIP, 600 mils width, Package Mechanical Data .....	23
<b>PART NUMBERING</b> .....	<b>24</b>
Table 17. Ordering Information Scheme .....	24
<b>REVISION HISTORY</b> .....	<b>25</b>
Table 18. Document Revision History .....	25

**SUMMARY DESCRIPTION**

The M27W016 is a 16 Mbit (2Mb x16) non-volatile, One Time Programmable (OTP), FlexibleROM™ Memory. Read operations can be performed using a single low voltage (2.7 to 3.6V) supply. Program operations require an additional V<sub>PP</sub> (11.4 to 12.6V) power supply. On power-up the memory defaults to Read mode where it can be read in the same way as a ROM or EPROM.

Program commands are written to the Command Interface of the memory. An on-chip Program Controller (PC) simplifies the process of programming the memory by taking care of all of the special operations that are required to update the memory contents.

The M27W016 features an innovative command, Multiple Word Program, used to program large streams of data. It greatly reduces the total pro-

gramming time when a large number of Words are written to the memory at any one time. Using this command the entire memory can be programmed in 2s, compared to 9s using the standard Word Program.

The end of a program operation can be detected and any error conditions identified. The command set required to control the memory is consistent with JEDEC standards.

Chip Enable and Output Enable signals control the bus operation of the memory. They allow simple connection to most microprocessors, often without additional logic.

The memory is offered in SO44, TSOP48 (12 x 20mm), PDIP42 and SDIP42 packages. The memory is supplied with all the bits set to '1'.

**Figure 2. Logic Diagram**

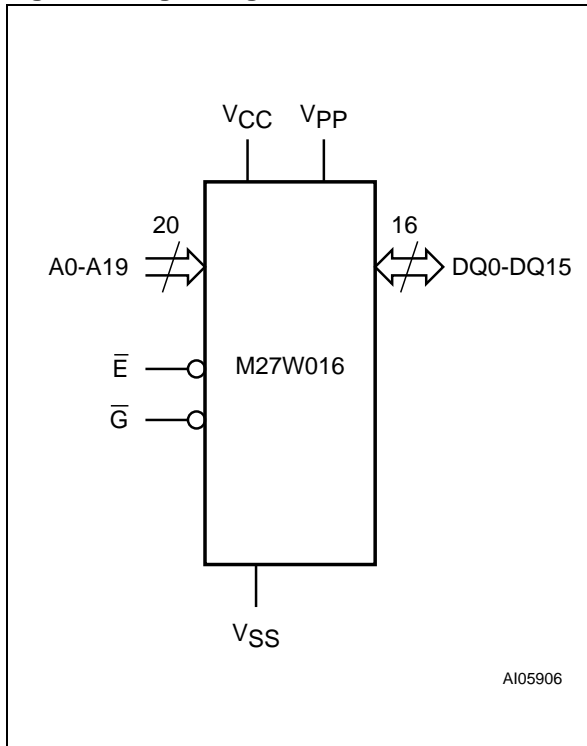

**Table 1. Signal Names**

A0-A19	Address Inputs
DQ0-DQ15	Data Inputs/Outputs
$\bar{E}$	Chip Enable
$\bar{G}$	Output Enable
V <sub>CC</sub>	Supply Voltage read
V <sub>PP</sub>	Supply Voltage program
V <sub>SS</sub>	Ground
NC	Not Connected Internally

Figure 3. PDIP Connections

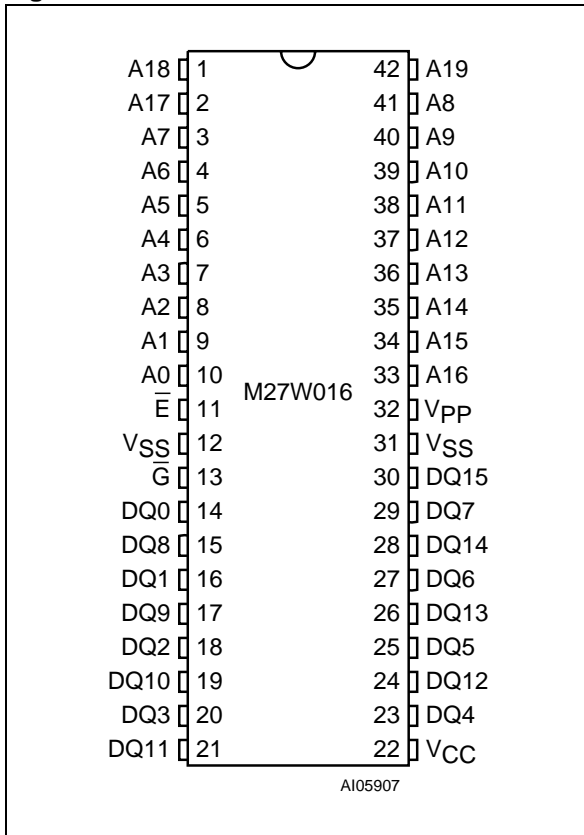

Figure 4. SDIP Connections

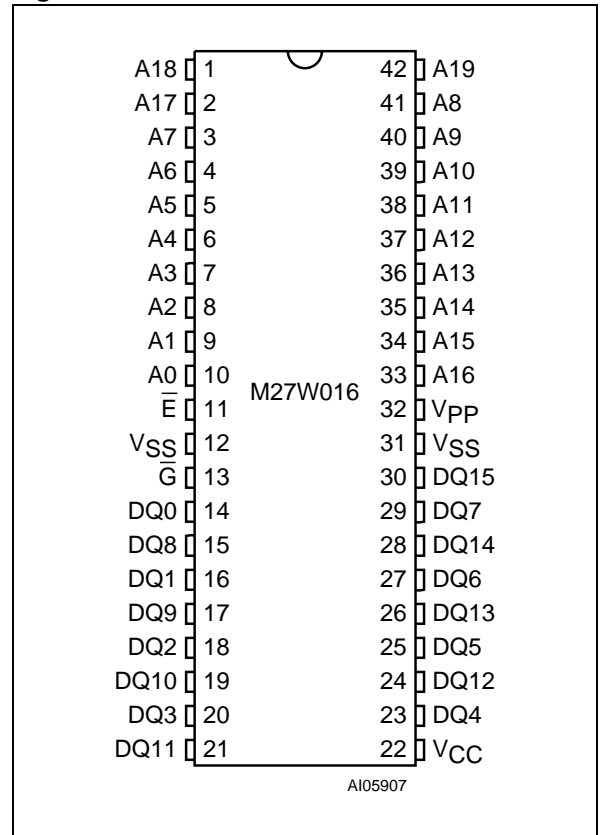

Figure 5. SO Connections

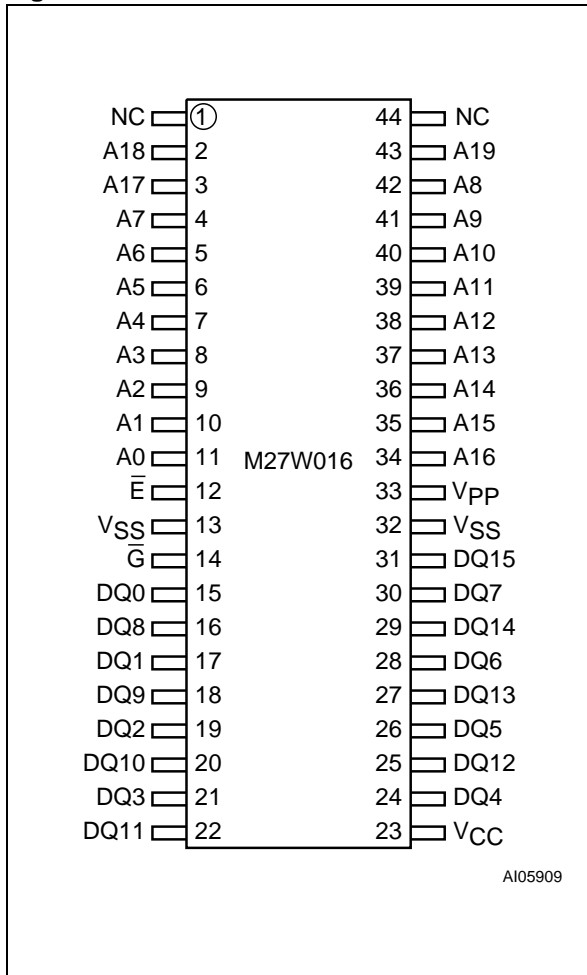
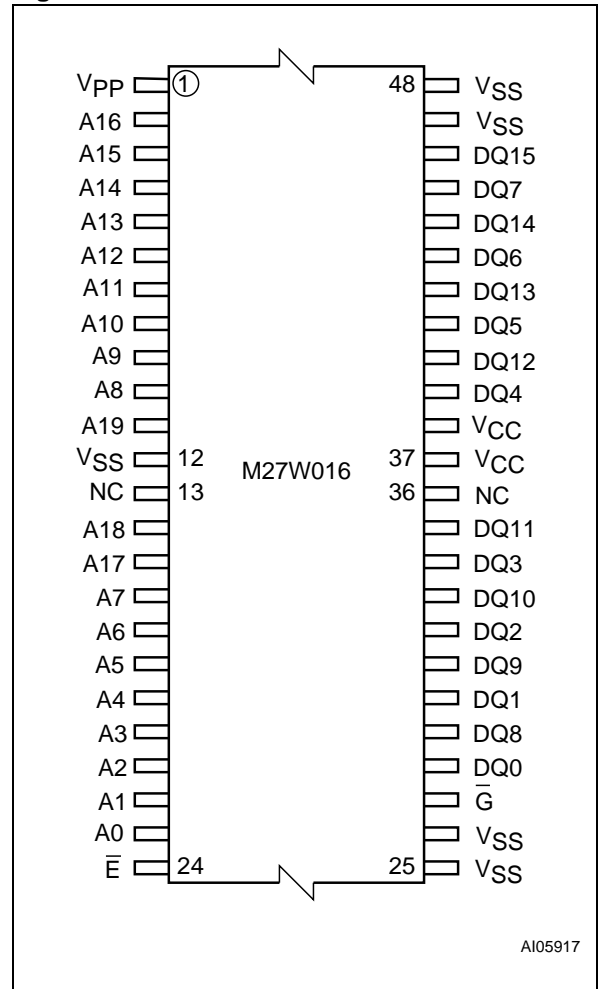

Figure 6. TSOP Connections



## SIGNAL DESCRIPTIONS

See Figure 2, Logic Diagram, and Table 1, Signal Names, for a brief overview of the signals connected to this device.

**Address Inputs (A0-A19).** The Address Inputs select the cells in the memory array to access during Bus Read operations. During Bus Write operations they control the commands sent to the Command Interface of the Program Controller.

**Data Inputs/Outputs (DQ0-DQ7).** The Data Inputs/Outputs output the data stored at the selected address during a Bus Read operation. During Bus Write operations they represent the command sent to the Command Interface of the Program Controller. When reading the Status Register they report the status of the ongoing algorithm.

**Data Inputs/Outputs (DQ8-DQ15).** The Data Inputs/Outputs output the data stored at the selected address during a Bus Read operation. During Bus Write operations the Command Interface does not use these bits. When reading the Status Register these bits should be ignored.

**Chip Enable ( $\bar{E}$ ).** The Chip Enable,  $\bar{E}$ , activates the memory, allowing Bus Read operations to be performed. It also controls the Bus Write operations, when  $V_{PP}$  is in the  $V_{HH}$  range.

**Output Enable ( $\bar{G}$ ).** The Output Enable,  $\bar{G}$ , controls the Bus Read operations of the memory. It

also allows Bus Write operations, when  $V_{PP}$  is in the  $V_{HH}$  range.

**V<sub>CC</sub> Supply Voltage.** The  $V_{CC}$  Supply Voltage supplies the power for Read operations.

A 0.1 $\mu$ F capacitor should be connected between the  $V_{CC}$  Supply Voltage pin and the  $V_{SS}$  Ground pin to decouple the current surges from the power supply. The PCB track widths must be sufficient to carry the currents required during program operations,  $I_{CC3}$ .

**V<sub>PP</sub> Program Supply Voltage.**  $V_{PP}$  is both a power supply and Write Protect pin. The two functions are selected by the voltage range applied to the pin.

When the  $V_{PP}$  is in the  $V_{HH}$  range (see Table 10, DC Characteristic, for the relevant values) the Program operation is enabled. During such operations the  $V_{PP}$  must be stable in the  $V_{HH}$  range.

If the  $V_{PP}$  is kept under the  $V_{HH}$  range, particularly in the voltage range 0 to 3.6V, any Program operation is disabled or stopped.

Note that  $V_{PP}$  must not be left floating or unconnected as the device may become unreliable.

**V<sub>SS</sub> Ground.** The  $V_{SS}$  Ground is the reference for all voltage measurements.

## BUS OPERATIONS

There are six standard bus operations that control the device. These are Bus Read, Bus Write, Output Disable, Standby, Automatic Standby and Electronic Signature. See Tables 2, Bus Operations, for a summary. Typically glitches of less than 5ns on Chip Enable or Write Enable are ignored by the memory and do not affect bus operations.

**Bus Read.** Bus Read operations read from the memory cells, or specific registers in the Command Interface. A valid Bus Read operation involves setting the desired address on the Address Inputs and applying a Low signal,  $V_{IL}$ , to Chip Enable and Output Enable. The Data Inputs/Outputs will output the value, see Figure 12, Read AC Waveforms, and Table 11, Read AC Characteristics, for details of when the output becomes valid.

**Bus Write.** Bus Write operations write to the Command Interface. Bus Write is enabled only when  $V_{PP}$  is set to  $V_{HH}$ . A valid Bus Write operation begins by setting the desired address on the Address Inputs. The Address Inputs are latched by the Command Interface on the falling edge of Chip Enable. The Data Inputs/Outputs are latched by the Command Interface on the rising edge of Chip Enable. Output Enable must remain High,  $V_{IH}$ , during the whole Bus Write operation. See Figure 13, Write AC Waveforms, and Table 12, Write AC Characteristics, for details of the timing requirements.

**Output Disable.** The Data Inputs/Outputs are in the high impedance state when Output Enable is High,  $V_{IH}$ .

**Standby.** When Chip Enable is High,  $V_{IH}$ , the memory enters Standby mode and the Data Inputs/Outputs pins are placed in the high-impedance state. To reduce the Supply Current to the Standby Supply Current,  $I_{CC2}$ , Chip Enable should be held within  $V_{CC} \pm 0.2V$ . For the Standby current level see Table 10, DC Characteristics.

During program operation the memory will continue to use the Program Supply Current,  $I_{CC3}$ , for Program operation until the operation completes.

**Automatic Standby.** If CMOS levels ( $V_{CC} \pm 0.2V$ ) are used to drive the bus and the bus is inactive for 150ns or more the memory enters Automatic Standby where the internal Supply Current is reduced to the Standby Supply Current,  $I_{CC2}$ . The Data Inputs/Outputs will still output data if a Bus Read operation is in progress.

**Electronic Signature.** The memory has two codes, the manufacturer code and the device code, that can be read to identify the memory. These codes can be read by applying the signals listed in Tables 2, Bus Operations, once the Auto Select Command is executed. To exit Electronic Signature mode, the Read/Reset command must be issued.

**Table 2. Bus Operations**

Operation	$\bar{E}$	$\bar{G}$	$V_{PP}$	Address Inputs A0-A19	Data Inputs/Outputs DQ15-DQ0
Bus Read	$V_{IL}$	$V_{IL}$	XX <sup>(3)</sup>	Cell Address	Data Output
Bus Write	$V_{IL}$	$V_{IH}$	$V_{HH}$	Command Address	Data Input
Output Disable	X	$V_{IH}$	X	X	Hi-Z
Standby	$V_{IH}$	X	X	X	Hi-Z
Read Manufacturer Code	$V_{IL}$	$V_{IL}$	$V_{HH}$	A0 = $V_{IL}$ , A1 = $V_{IL}$ , Others $V_{IL}$ or $V_{IH}$	0020h
Read Device Code	$V_{IL}$	$V_{IL}$	$V_{HH}$	A0 = $V_{IH}$ , A1 = $V_{IL}$ , Others $V_{IL}$ or $V_{IH}$	888Dh

Note: 1. X =  $V_{IL}$  or  $V_{IH}$ .

2. XX =  $V_{IL}$ ,  $V_{IH}$  or  $V_{HH}$

3. When reading Status Register during Program algorithm execution  $V_{PP}$  must be kept at  $V_{HH}$ .



## COMMAND INTERFACE

All Bus Write operations to the memory are interpreted by the Command Interface. Commands consist of one or more sequential Bus Write operations. Failure to observe a valid sequence of Bus Write operations will result in the memory returning to Read mode. The long command sequences are imposed to maximize data security.

Refer to Tables 3 and 4, for a summary of the commands.

### Read/Reset Command.

The Read/Reset command returns the memory to its Read mode where it behaves like a ROM or EPROM, unless otherwise stated. It also resets the errors in the Status Register. Either one or three Bus Write operations can be used to issue the Read/Reset command.

$V_{PP}$  must be set to  $V_{HH}$  during the Read/Reset command. If  $V_{PP}$  is set to either  $V_{IL}$  or  $V_{IH}$  the command will be ignored. The command can be issued, between Bus Write cycles before the start of a program operation, to return the device to read mode. Once the program operation has started the Read/Reset command is no longer accepted.

### Auto Select Command.

The Auto Select command is used to read the Manufacturer Code and the Device Code.  $V_{PP}$  must be set to  $V_{HH}$  during the Auto Select command. If  $V_{PP}$  is set to either  $V_{IL}$  or  $V_{IH}$  the command will be ignored. Three consecutive Bus Write operations are required to issue the Auto Select command. Once the Auto Select command is issued the memory remains in Auto Select mode until a Read/Reset command is issued, all other commands are ignored.

From the Auto Select mode the Manufacturer Code can be read using a Bus Read operation with  $A0 = V_{IL}$  and  $A1 = V_{IL}$ . The other address bits may be set to either  $V_{IL}$  or  $V_{IH}$ .

The Device Code can be read using a Bus Read operation with  $A0 = V_{IH}$  and  $A1 = V_{IL}$ . The other address bits may be set to either  $V_{IL}$  or  $V_{IH}$ .

### Word Program Command.

The Word Program command can be used to program a Word to the memory array.  $V_{PP}$  must be set to  $V_{HH}$  during Word Program. If  $V_{PP}$  is set to either  $V_{IL}$  or  $V_{IH}$  the command will be ignored, the data will remain unchanged and the device will revert to Read/Reset mode. The command requires four Bus Write operations, the final write operation latches the address and data in the internal state machine and starts the PC.

During the program operation the memory will ignore all commands. It is not possible to issue any command to abort or pause the operation. Typical program times are given in Table 5. Bus Read op-

erations during the program operation will output the Status Register on the Data Inputs/Outputs. See the section on the Status Register for more details.

After the program operation has completed the memory will return to the Read mode, unless an error has occurred. When an error occurs the memory will continue to output the Status Register. A Read/Reset command must be issued to reset the error condition and return to Read mode.

Note that the Program command cannot change a bit set at '0' back to '1'.

### Multiple Word Program Command

The Multiple Word Program command can be used to program large streams of data. It greatly reduces the total programming time when a large number of Words are written in the memory at once.  $V_{PP}$  must be set to  $V_{HH}$  during Multiple Word Program. If  $V_{PP}$  is set either  $V_{IL}$  or  $V_{IH}$  the command will be ignored, the data will remain unchanged and the device will revert to Read mode.

It has four phases: the Setup Phase to initiate the command, the Program Phase to program the data to the memory, the Verify Phase to check that the data has been correctly programmed and re-program if necessary and the Exit Phase.

**Setup Phase.** The Multiple Word Program command requires three Bus Write operations to initiate the command (refer to Table 4, Multiple Word Program Command and Figure 8, Multiple Word Program Flowchart).

The Status Register must be read in order to check that the PC has started (see Table 6 and Figure 8).

**Program Phase.** The Program Phase requires  $n+1$  Bus Write operations, where  $n$  is the number of Words, to execute the programming phase (refer to Table 4, Multiple Word Program and Figure 7, Multiple Word Program Flowchart).

Before any Bus Write operation of the Program Phase, the Status Register must be read in order to check that the PC is ready to accept the operation (see Table 6 and Figure 8).

The Program Phase is executed in three different sub-phases:

1. The first Bus Write operation of the Program Phase (the 4th of the command) latches the Start Address and the first Word to be programmed.
2. Each subsequent Bus Write operation latches the next Word to be programmed and automatically increments the internal Address Bus. It is not necessary to provide the address of the location to be programmed but only a Continue Address, CA (A17 to A19 equal to the

Start Address), that indicates to the PC that the Program Phase has to continue. A0 to A16 are 'don't care'.

3. Finally, after all Words have been programmed, a Bus Write operation (the  $(n+1)^{\text{th}}$ ) with a Final Address, FA (A17 or a higher address pin different from the Start Address), ends the Program Phase.

The memory is now set to enter the Verify Phase.

**Verify Phase.** The Verify Phase is similar to the Program Phase in that all Words must be resent to the memory for them to be checked against the programmed data.

Before any Bus Write Operation of the Verify Phase, the Status Register must be read in order to check that the PC is ready for the next operation or if the reprogram of the location has failed (see Table 6 and Figure 8).

Three successive steps are required to execute the Verify Phase of the command:

1. The first Bus Write operation of the Verify Phase latches the Start Address and the Word to be verified.
2. Each subsequent Bus Write operation latches the next Word to be verified and automatically increments the internal Address Bus. As in the Program Phase, it is not necessary to provide the address of the location to be programmed

but only a Continue Address, CA (A17 to A19 equal to the Start Address).

3. Finally, after all Words have been verified, a Bus Write cycle with a Final Address, FA (A17 or a higher address pin different from the Start Address) ends the Verify Phase.

**Exit Phase.** After the Verify Phase ends, the Status Register must be read to check if the command has successfully completed or not (see Table 6 and Figure 8).

If the Verify Phase is successful, the memory returns to Read mode and DQ6 stops toggling.

If the PC fails to reprogram a given location, the Verify Phase terminates, DQ6 continues toggling and error bit DQ5 is set in the Status Register. If the error is due to a  $V_{PP}$  failure DQ4 is also set.

When the operation fails a Read/Reset command must be issued to return the device to Read mode.

During the Multiple Word Program operation the memory will ignore all commands. It is not possible to issue any command to abort or pause the operation. Typical program times are given in Table 5. Bus Read operations during the program operation will output the Status Register on the Data Inputs/Outputs. See the section on the Status Register for more details.

Note that the Multiple Word Program command cannot change a bit set to '0' back to '1'.

Table 3. Standard Commands

Command	Length	Bus Write Operations							
		1st		2nd		3rd		4th	
		Add	Data	Add	Data	Add	Data	Add	Data
Read/Reset	1	X	F0						
	3	555	AA	2AA	55	X	F0		
Auto Select	3	555	AA	2AA	55	555	90		
Word Program	4	555	AA	2AA	55	555	A0	PA	PD

Note: X Don't Care, PA Program Address, PD Program Data. All values in the table are in hexadecimal. The Command Interface only uses A0-A10 and DQ0-DQ7 to verify the commands; A11-A19, DQ8-DQ15 are Don't Care.

Table 4. Multiple Word Program Command

Phase	Length	Bus Write Operations														
		1st		2nd		3rd		4th		5th		nth		Final		
		Add	Data	Add	Data	Add	Data	Add	Data	Add	Data	Add	Data	Add	Data	
Set-Up	3	555	AA	2AA	55	555	20									
Program	n+1	SA	PD1	CA	PD2	CA	PD3	CA	PD4	CA	PD5		CA	PAn	FA	X
Verify	n+1	SA	PD1	CA	PD2	CA	PD3	CA	PD4	CA	PD5		CA	PAn	FA	X

Note: A Bus Read must be done between each Write cycle where the data is programmed or verified, to Read the Status Register and check that the memory is ready to accept the next data. SA is the Start Address. CA is the Continue Address. FA is the Final Address. X Don't Care, n = number of Words to be programmed.

Table 5. Program Times

Parameter	Typ <sup>(1)</sup>	Max	Unit
Program (Word)	9	200	μs
Chip Program (Multiple Word)	2	35	s
Chip Program (Word by Word)	9	35	s

Note: 1. T<sub>A</sub> = 25°C, V<sub>PP</sub> = 12V.

Figure 7. Multiple Word Program Flowchart

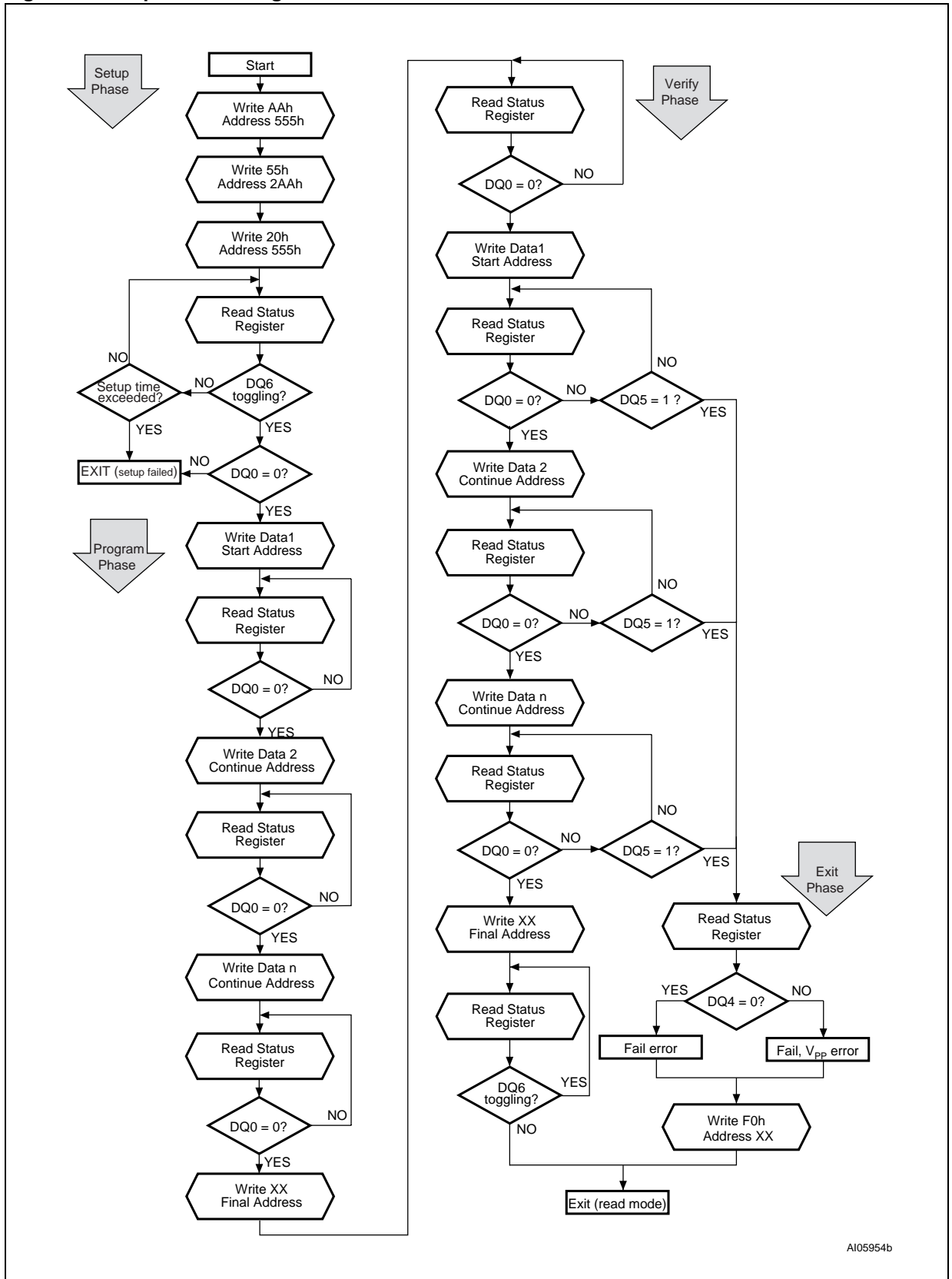

AI05954b

## STATUS REGISTER

Bus Read operations from any address always read the Status Register during Program operations. The bits in the Status Register are summarized in Table 6, Status Register Bits.

**Data Polling Bit (DQ7).** The Data Polling Bit can be used to identify whether the Program Controller has successfully completed its operation. The Data Polling Bit is output on DQ7 when the Status Register is read.

During a Word Program operation the Data Polling Bit outputs the complement of the bit being programmed to DQ7. After successful completion of the Word Program operation the memory returns to Read mode and Bus Read operations from the address just programmed output DQ7, not its complement.

Figure 8, Data Polling Flowchart, gives an example of how to use the Data Polling Bit. A Valid Address is the address being programmed.

**Toggle Bit (DQ6).** The Toggle Bit can be used to identify whether the Program Controller has successfully completed its operation. The Toggle Bit is output on DQ6 when the Status Register is read.

During Program operations the Toggle Bit changes from '0' to '1' to '0', etc., with successive Bus Read operations at any address. After successful completion of the operation the memory returns to Read mode.

Figure 9, Data Toggle Flowchart, gives an example of how to use the Data Toggle Bit.

**Error Bit (DQ5).** The Error Bit can be used to identify errors detected by the Program Controller. The Error Bit is set to '1' when a Program operation fails to write the correct data to the memory. If the Error Bit is set a Read/Reset command must be issued before other commands are issued. The Error bit is output on DQ5 when the Status Register is read.

Note that the Program command cannot change a bit set to '0' back to '1' and attempting to do so will set DQ5 to '1'. A Bus Read operation to that address will show the bit is still '0'.

**V<sub>PP</sub> Status Bit (DQ4).** The V<sub>PP</sub> Status Bit can be used to identify if any Program operation has failed due to a V<sub>PP</sub> error. If V<sub>PP</sub> falls below V<sub>HH</sub> during any Program operation, the operation aborts and DQ4 is set to '1'. If V<sub>PP</sub> remains at V<sub>HH</sub> throughout the Program operation, the operation completes and DQ4 is set to '0'.

**Multiple Word Program Bit (DQ0).** The Multiple Word Program Bit can be used to indicate whether the Program Controller is active or inactive during Multiple Word Program. When the Program Controller has written one Word and is ready to accept the next Word, the bit is set to '0'.

**Status Register Bit DQ1 is reserved.**

**Table 6. Status Register Bits**

Command (1)	P.C. Status	DQ7	DQ6	DQ5	DQ4	DQ3	DQ0
Multiple Word Program	Programming	–	Toggle	0	–	0	1
	Waiting for data	–	Toggle	0	–	0	0
	Program fail	–	Toggle	1	(2)	0	1
Word Program	Programming	$\overline{\text{DQ7}}$	Toggle	0	–	0	–
	Program error	$\overline{\text{DQ7}}$	Toggle	1	(2)	0	–

Note: 1. Unspecified data bits should be ignored.

2. DQ4 = 0 if  $V_{PP} \geq V_{HH}$  during Program algorithm execution; DQ4 = 1 if  $V_{PP} < V_{HH}$  during Program algorithm execution.

**Figure 8. Data Polling Flowchart**

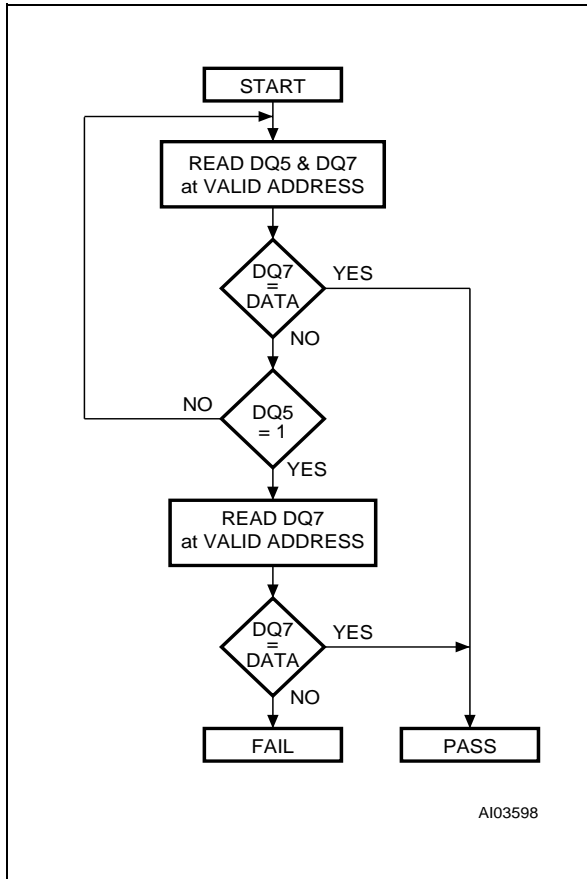

**Figure 9. Data Toggle Flowchart**

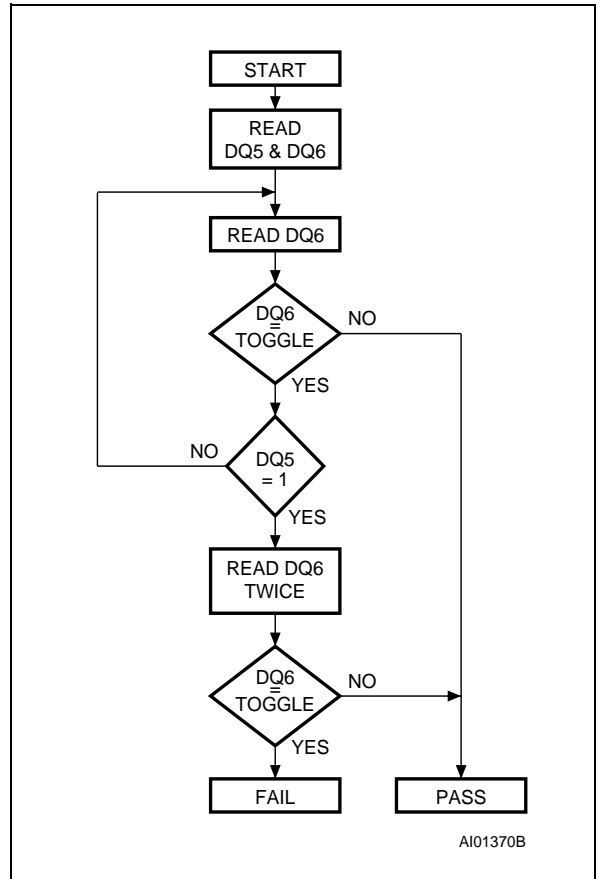

## MAXIMUM RATING

Stressing the device above the rating listed in the Absolute Maximum Ratings" table may cause permanent damage to the device. Exposure to Absolute Maximum Rating conditions for extended periods may affect device reliability. These are stress ratings only and operation of the device at

these or any other conditions above those indicated in the Operating sections of this specification is not implied. Refer also to the STMicroelectronics SURE Program and other relevant quality documents.

**Table 7. Absolute Maximum Ratings**

Symbol	Parameter	Min	Max	Unit
T <sub>BIAS</sub>	Temperature Under Bias	-50	125	°C
T <sub>STG</sub>	Storage Temperature	-65	150	°C
V <sub>IO</sub>	Input or Output Voltage <sup>(1,2)</sup>	-0.6	V <sub>CC</sub> +0.6	V
V <sub>CC</sub>	Read Supply Voltage	-0.6	4	V
V <sub>PP</sub>	Program Supply Voltage <sup>(3)</sup>	-0.6	13.5	V

Note: 1. Minimum voltage may undershoot to -2V for less than 20ns during transitions.

2. Maximum voltage may overshoot to V<sub>CC</sub> +2V for less than 20ns during transitions.

3. Maximum voltage may overshoot to 14.0V for less than 20ns during transitions. V<sub>PP</sub> must not remain at V<sub>HH</sub> for more than a total of 80hrs.

**DC AND AC PARAMETERS**

This section summarizes the operating measurement conditions, and the DC and AC characteristics of the device. The parameters in the DC and AC characteristics Tables that follow, are derived from tests performed under the Measurement

Conditions summarized in Table 8, Operating and AC Measurement Conditions. Designers should check that the operating conditions in their circuit match the operating conditions when relying on the quoted parameters.

**Table 8. Operating and AC Measurement Conditions**

Parameter	M27W016		Unit
	100, 110		
	Min	Max	
V <sub>CC</sub> Read Supply Voltage	2.7	3.6	V
V <sub>PP</sub> Program Supply Voltage	11.4	12.6	V
Ambient Operating Temperature	0	70	°C
Load Capacitance (C <sub>L</sub> )	30		pF
Input Rise and Fall Times		10	ns
Input Pulse Voltages	0 to 3		V
Input and Output Timing Ref. Voltages	1.5		V

**Figure 10. AC Measurement I/O Waveform**

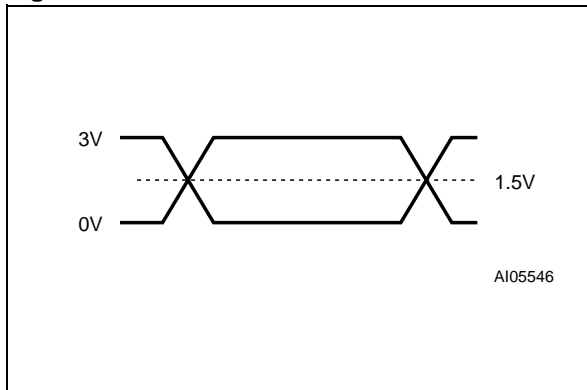

**Figure 11. AC Measurement Load Circuit**

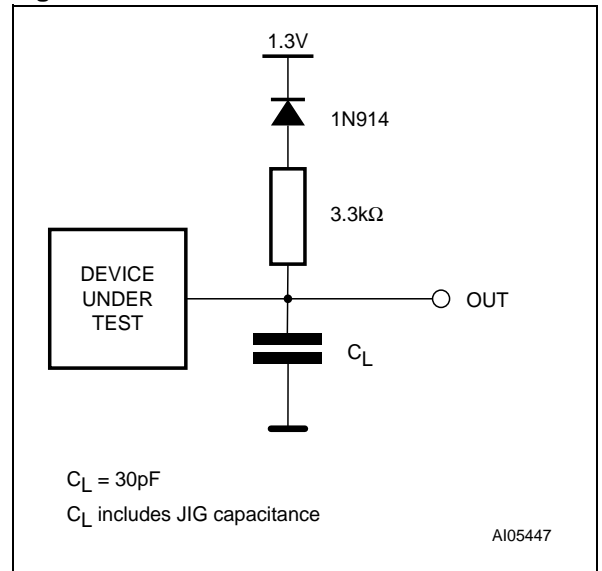

**Table 9. Device Capacitance**

Symbol	Parameter	Test Condition	Min	Max	Unit
C <sub>IN</sub>	Input Capacitance	V <sub>IN</sub> = 0V		6	pF
C <sub>OUT</sub>	Output Capacitance	V <sub>OUT</sub> = 0V		12	pF

Note: Sampled only, not 100% tested.



Table 10. DC Characteristics

Symbol	Parameter <sup>(1)</sup>	Test Condition	Min	Max	Unit
I <sub>LI</sub>	Input Leakage Current	$0V \leq V_{IN} \leq V_{CC}$		±1	μA
I <sub>LO</sub>	Output Leakage Current	$0V \leq V_{OUT} \leq V_{CC}$		±1	μA
I <sub>CC1</sub>	Supply Current (Read)	$\bar{E} = V_{IL}, \bar{G} = V_{IH},$ $I_{OUT} = 0mA, f = 6MHz$		10	mA
I <sub>CC2</sub> <sup>(2)</sup>	Supply Current (Standby)	$\bar{E} = V_{CC} \pm 0.2V$		100	μA
I <sub>CC3</sub>	Supply Current (Program)	PC active		20	mA
V <sub>IL</sub>	Input Low Voltage		-0.5	0.8	V
V <sub>IH</sub>	Input High Voltage		$0.7V_{CC}$	$V_{CC} + 0.3$	V
V <sub>OL</sub>	Output Low Voltage	$I_{OL} = 1.8mA$		0.45	V
V <sub>OH</sub>	Output High Voltage	$I_{OH} = -100\mu A$	$V_{CC} - 0.4$		V
V <sub>HH</sub>	V <sub>PP</sub> Program Voltage		11.4	12.6	V
I <sub>HH</sub>	V <sub>PP</sub> Current (Program)	PC Active		10	mA

Note: 1. V<sub>CC</sub> must be applied simultaneously or before V<sub>PP</sub> and removed simultaneously or after V<sub>PP</sub>.

2. Average Value.

Figure 12. Read AC Waveforms

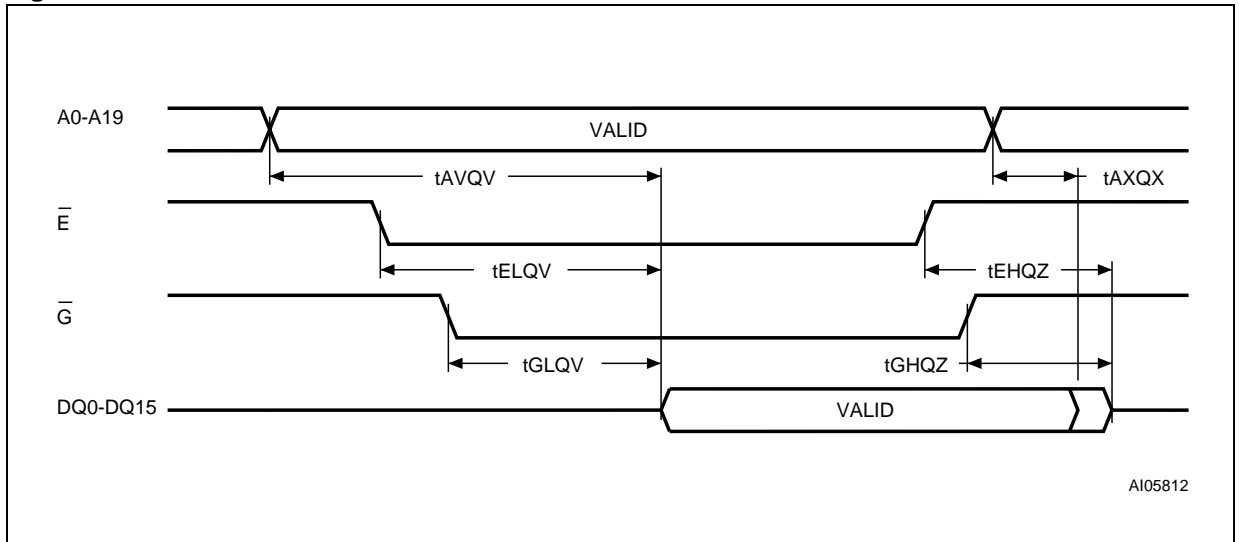

Table 11. Read AC Characteristics

Symbol	Alt	Parameter <sup>(1)</sup>	Test Condition		M27W016			Unit
					100		110	
					$V_{CC} = 3.0 \text{ to } 3.6V$	$V_{CC} = 2.7 \text{ to } 3.6V$	$V_{CC} = 2.7 \text{ to } 3.6V$	
$t_{AVQV}$	$t_{ACC}$	Address Valid to Output Valid	$\overline{E} = V_{IL}$ , $\overline{G} = V_{IL}$	Max	90	100	110	ns
$t_{ELQV}$	$t_{CE}$	Chip Enable Low to Output Valid	$\overline{G} = V_{IL}$	Max	90	100	110	ns
$t_{GLQV}$	$t_{OE}$	Output Enable Low to Output Valid	$\overline{E} = V_{IL}$	Max	35	35	35	ns
$t_{EHQZ}^{(2)}$	$t_{HZ}$	Chip Enable High to Output Hi-Z	$\overline{G} = V_{IL}$	Max	30	30	30	ns
$t_{GHQZ}^{(2)}$	$t_{DF}$	Output Enable High to Output Hi-Z	$\overline{E} = V_{IL}$	Max	30	30	30	ns
$t_{AXQX}$	$t_{OH}$	Address Transition to Output Transition		Min	0	0	0	ns

Note: 1.  $V_{PP}$  must be applied after  $V_{CC}$  and with the Chip Enable ( $\overline{E}$ ) at  $V_{IH}$ .

2. Sampled only, not 100% tested.

Figure 13. Chip Enable Controlled, Write AC Waveforms

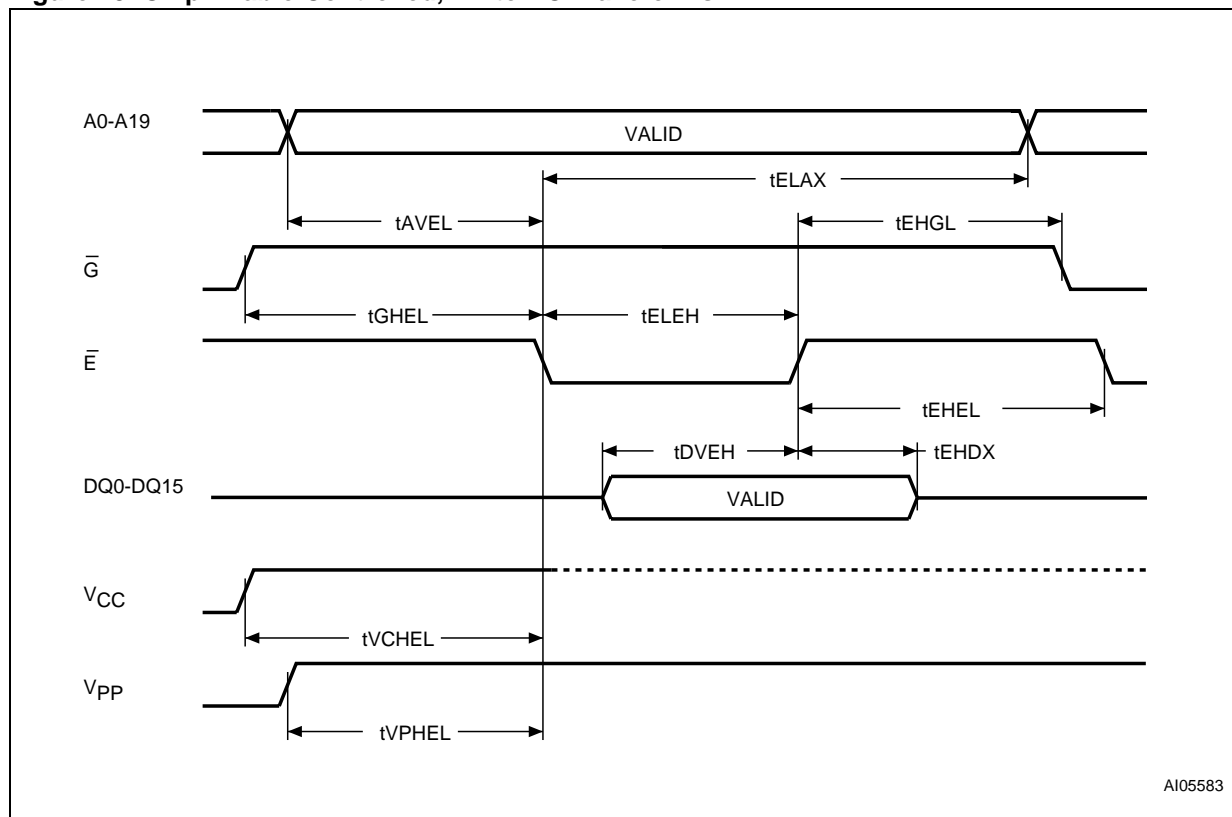

Table 12. Chip Enable Controlled, Write AC Characteristics

Symbol	Alt	Parameter <sup>(1)</sup>		M27W016	Unit
t <sub>ELEH</sub>	t <sub>CP</sub>	Chip Enable Low to Chip Enable High	Min	50	ns
t <sub>DVEH</sub>	t <sub>DS</sub>	Input Valid to Chip Enable High	Min	50	ns
t <sub>EHDX</sub>	t <sub>DH</sub>	Chip Enable High to Input Transition	Min	0	ns
t <sub>EHEL</sub>	t <sub>CPH</sub>	Chip Enable High to Chip Enable Low	Min	50	ns
t <sub>AVEL</sub>	t <sub>AS</sub>	Address Valid to Chip Enable Low	Min	0	ns
t <sub>ELAX</sub>	t <sub>AH</sub>	Chip Enable Low to Address Transition	Min	100	ns
t <sub>GHEL</sub>		Output Enable High Chip Enable Low	Min	10	ns
t <sub>EHGL</sub>	t <sub>OEHL</sub>	Chip Enable High to Output Enable Low	Min	10	ns
t <sub>VCHEL</sub>	t <sub>VCS</sub>	V <sub>CC</sub> High to Chip Enable Low	Min	50	μs
t <sub>VPHEL</sub> <sup>(2)</sup>	t <sub>VCS</sub>	V <sub>PP</sub> High to Chip Enable Low	Min	500	ns

Note: 1. T<sub>A</sub> = 25°C; V<sub>PP</sub> = 11.4 to 12.6V. V<sub>CC</sub> = 2.7 to 3.6V.  
V<sub>PP</sub> must be applied after V<sub>CC</sub> and with the Chip Enable ( $\bar{E}$ ) at V<sub>IH</sub>.  
Sampled only, not 100% tested.  
2. Not required in Auto Select or Read/Reset command sequences.

## PACKAGE MECHANICAL

Figure 14. SO44 - 44 lead Plastic Small Outline, 500 mils body width, Package Outline

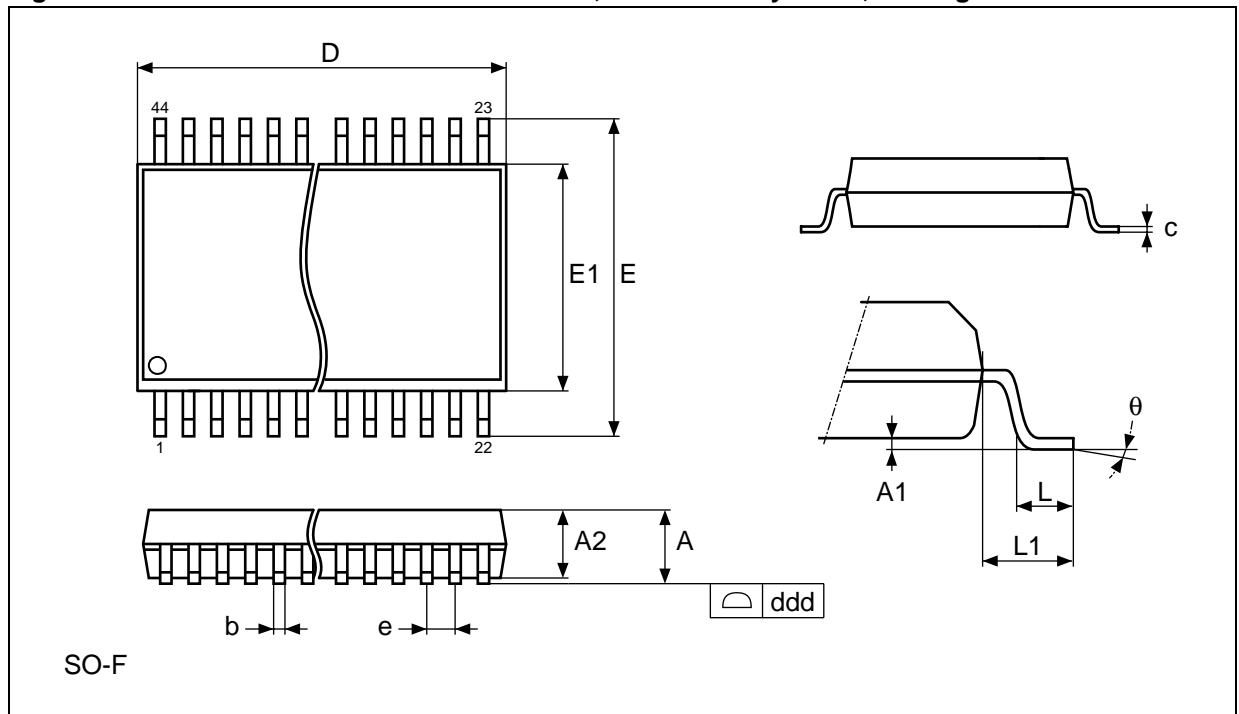

Note: Drawing is not to scale.

Table 13. SO44 - 44 lead Plastic Small Outline, 500 mils body width, Package Mechanical Data

Symbol	millimeters			inches		
	Typ	Min	Max	Typ	Min	Max
A			3.00			0.118
A1	0.10			0.004		
A2	2.69	2.56	2.79	0.106	0.101	0.110
b		0.35	0.50		0.014	0.020
c		0.18	0.28		0.007	0.011
D	28.50	28.37	28.63	1.122	1.117	1.127
ddd			0.10			0.004
E	16.03	15.77	16.28	0.631	0.621	0.641
E1	12.60	12.47	12.73	0.496	0.491	0.501
e	1.27	–	–	0.050	–	–
L	0.79			0.031		
L1	1.73			0.068		
θ			8°			8°
N	44			44		

Figure 15. TSOP48 - 48 lead Plastic Thin Small Outline, 12 x 20mm, Package Outline

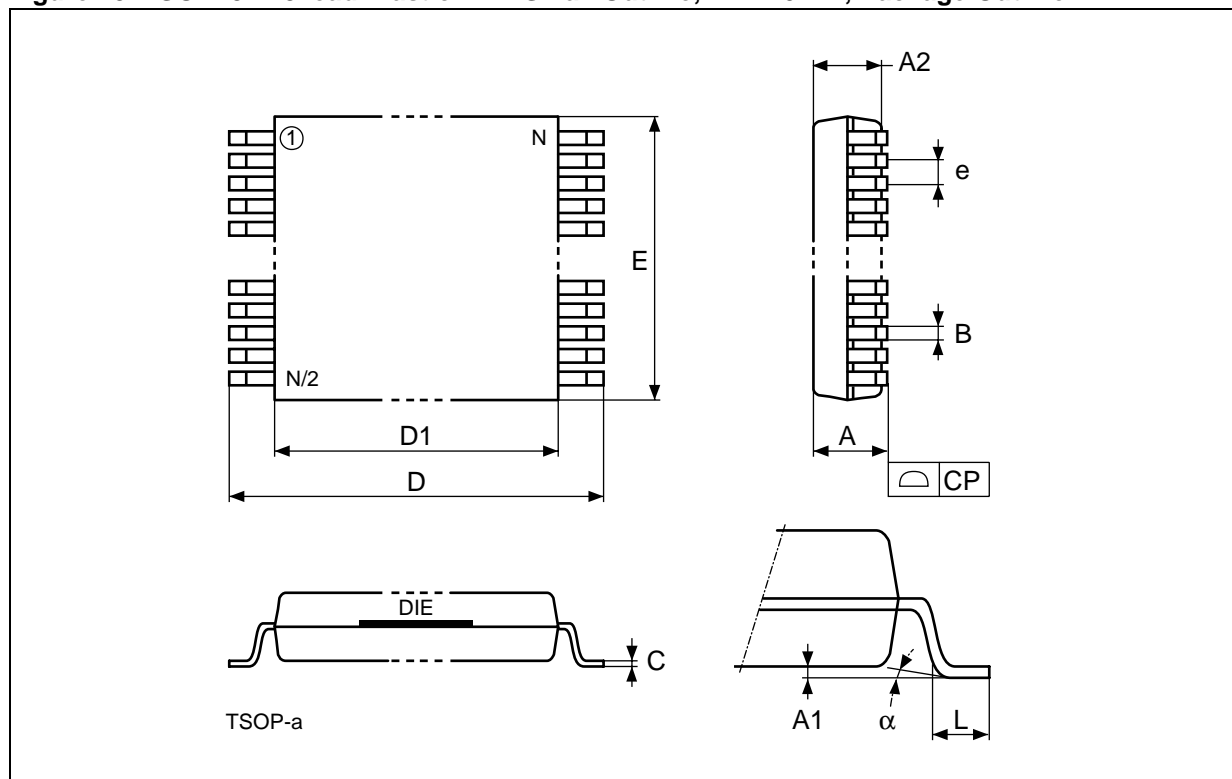

Note: Drawing is not to scale.

Table 14. TSOP48 - 48 lead Plastic Thin Small Outline, 12 x 20mm, Package Mechanical Data

Symbol	millimeters			inches		
	Typ	Min	Max	Typ	Min	Max
A			1.20			0.0472
A1		0.05	0.15		0.0020	0.0059
A2		0.95	1.05		0.0374	0.0413
B		0.17	0.27		0.0067	0.0106
C		0.10	0.21		0.0039	0.0083
CP			0.10			0.0039
D		19.80	20.20		0.7795	0.7953
D1		18.30	18.50		0.7205	0.7283
E		11.90	12.10		0.4685	0.4764
e	0.50	–	–	0.0197	–	–
L		0.50	0.70		0.0197	0.0276
α		0°	5°		0°	5°
N		48			48	

Figure 16. PDIP42 - 42 pin Plastic DIP, 600 mils width, Bottom View Package Outline

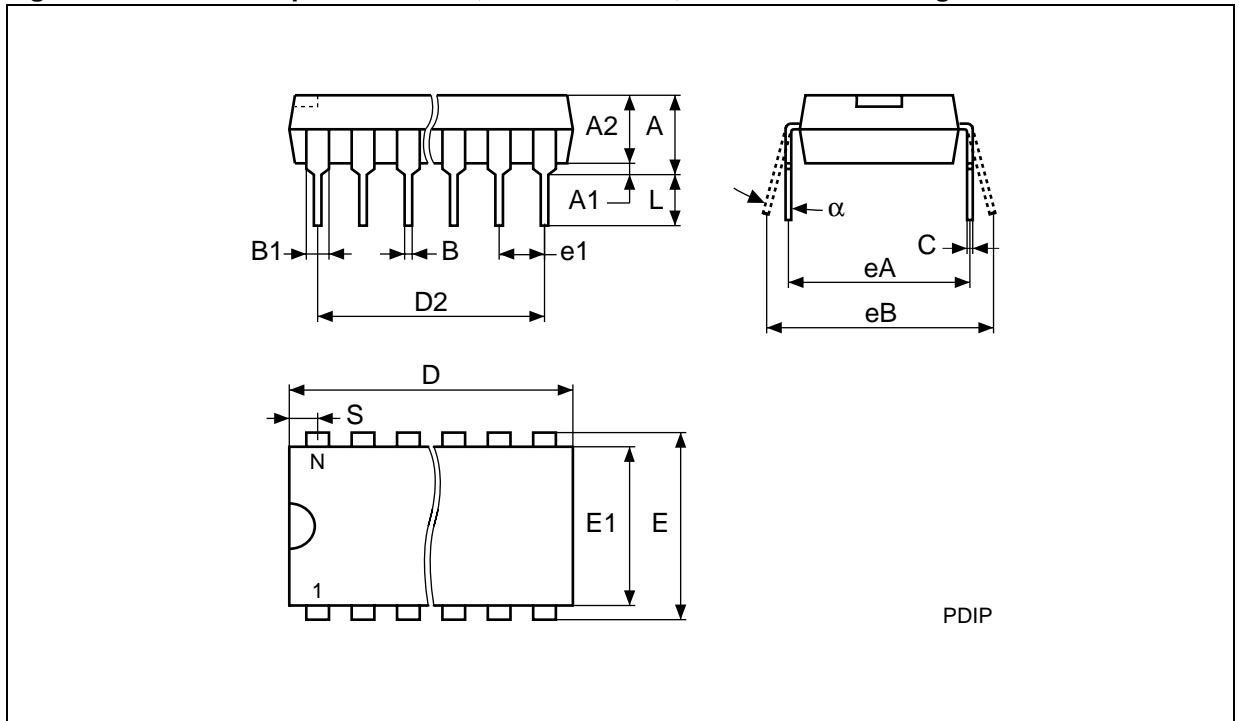

Note: Drawing is not to scale.

Table 15. PDIP42 - 42 pin Plastic DIP, 600 mils width, Package Mechanical Data

Symbol	millimeters			inches			
	Typ	Min	Max	Typ	Min	Max	
A		–	5.08		–	0.200	
A1		0.25	–		0.010	–	
A2		3.56	4.06		0.140	0.160	
B		0.38	0.53		0.015	0.021	
B1		1.27	1.65		0.050	0.065	
C		0.20	0.36		0.008	0.014	
D		52.20	52.71		2.055	2.075	
D2	50.80	–	–	2.000	–	–	
E	15.24	–	–	0.600	–	–	
E1		13.59	13.84		0.535	0.545	
e1	2.54	–	–	0.100	–	–	
eA	14.99	–	–	0.590	–	–	
eB		15.24	17.78		0.600	0.700	
L		3.18	3.43		0.125	0.135	
S		0.86	1.37		0.034	0.054	
α		0°	10°		0°	10°	
N		42				42	

Figure 17. SDIP42 - 42 pin Shrink Plastic DIP, 600 mils width, Package Outline

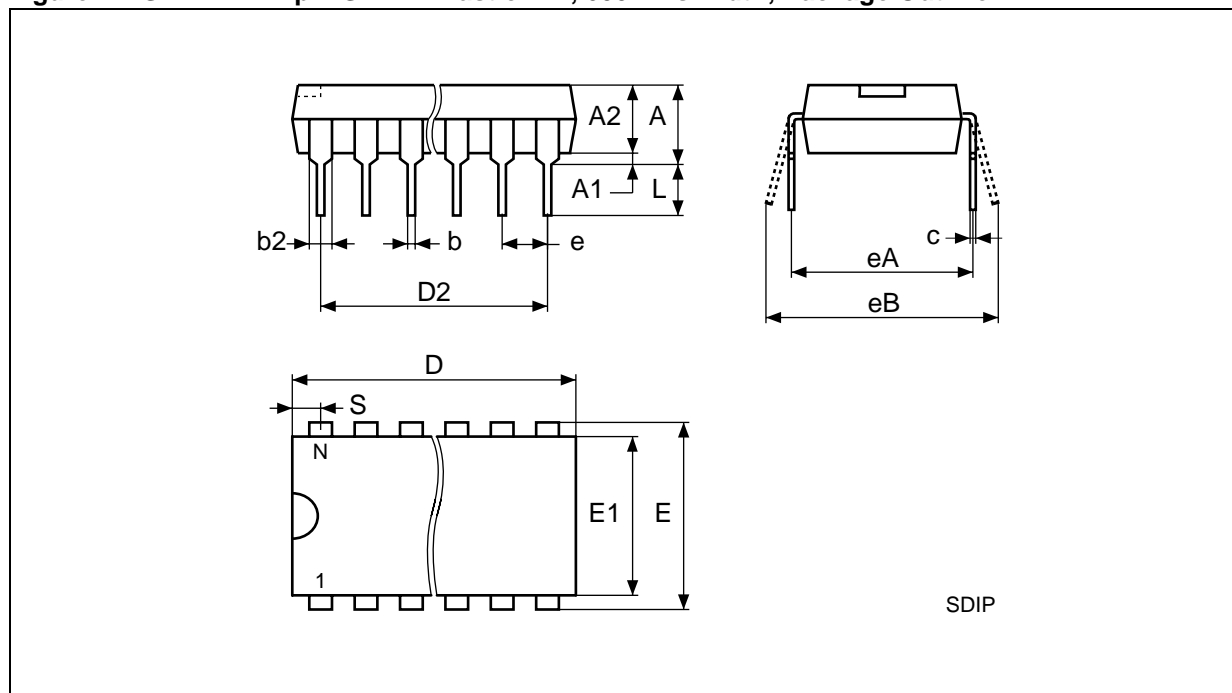

Note: Drawing is not to scale.

Table 16. SDIP42 - 42 pin Shrink Plastic DIP, 600 mils width, Package Mechanical Data

Symbol	millimeters			inches			
	Typ	Min	Max	Typ	Min	Max	
A			5.08			0.200	
A1		0.51			0.020		
A2	3.81	3.05	4.57	0.150	0.120	0.180	
b	0.46	0.38	0.56	0.018	0.015	0.022	
b2	1.02	0.89	1.14	0.040	0.035	0.045	
c	0.25	0.23	0.38	0.010	0.009	0.015	
D	36.83	36.58	37.08	1.450	1.440	1.460	
e	1.78	–	–	0.070	–	–	
E		15.24	16.00		0.600	0.630	
E1	13.72	12.70	14.48	0.540	0.500	0.570	
eA	15.24	–	–	0.600	–	–	
eB			18.54			0.730	
L	3.30	2.54	3.56	0.130	0.100	0.140	
S	0.64			0.025			
N		42				42	

**PART NUMBERING**

**Table 17. Ordering Information Scheme**

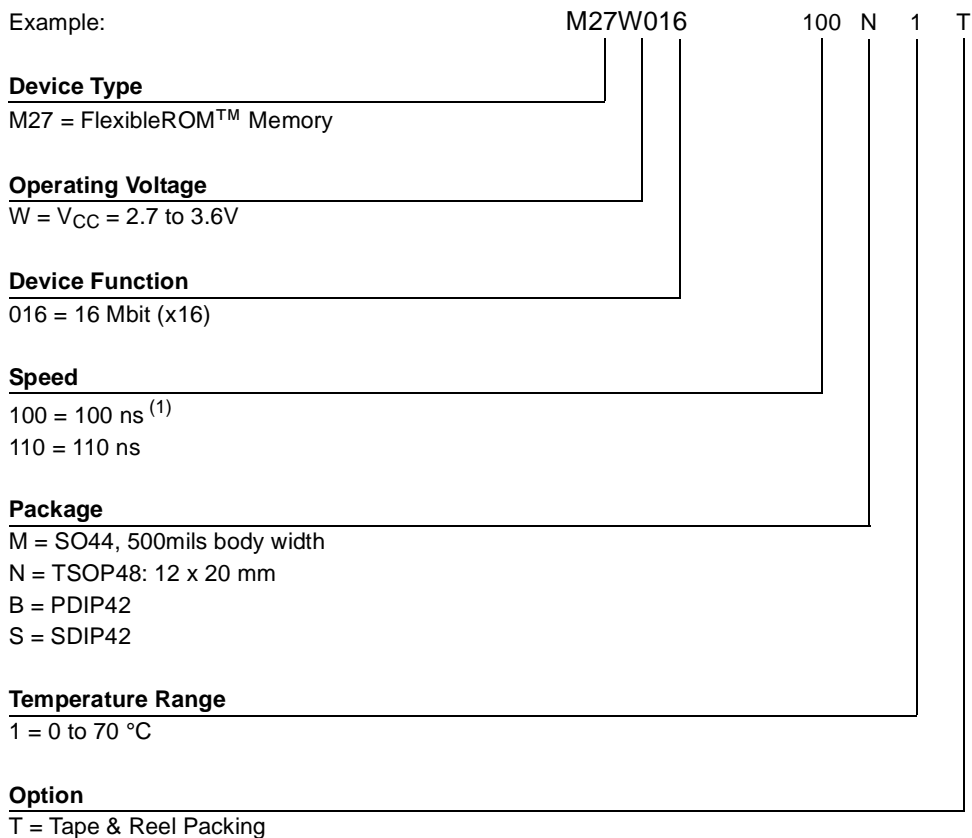

Note: 1. This speed also guarantees 90ns access time at V<sub>CC</sub> = 3.0 to 3.6V.

Devices are shipped from the factory with all the bits set to '1'.

For a list of available options (Speed, Package, etc...) or for further information on any aspect of this device, please contact the ST Sales Office nearest to you.



## REVISION HISTORY

**Table 18. Document Revision History**

Date	Version	Revision Details
28-Jan-2002	1.0	First Issue
15-May-2002	2.0	Output Enable paragraph clarified Electronic Signature paragraph clarified Multiple Word Command paragraph clarified (Paragraph rewritten, Table 4, Figure 7) Status Register Bits table clarified (Table 6) SO44 package mechanical data and drawing clarified (Figure 14, Table 13) PLCC44 package removed Document status changed to Product Preview
17-Jun-2002	3.0	Device classification changed to Fast OTP Program Phase and Verify Phase paragraphs clarified Standard Commands table clarified (Table 3) Multiple Word Program Command table and Flowchart clarified (Table 4, Figure 7) AC Measurement Load Circuit clarified (Figure 11) Read AC parameters clarified (Figure 12, Table 11) Chip Enable Controlled, Write AC parameters clarified (Figure 13, Table 12)
28-Jun-2002	4.0	Document status changed to Preliminary Data Document title clarified
09-Jul-2002	5.0	100ns speed class added (90ns at $V_{CC} = 3.0$ to $3.6V$ ) Product Name changed
31-Jul-2002	5.1	Multiple Word Program Command Table clarified (Table 4) $I_{CC1}$ , $I_{CC2}$ clarified (Table 10)
27-Sep-2002	5.2	Product Naming revised
14-Nov-2002	5.3	Document status changed to Datasheet OTP specification added SO44 package changed to 500mils body width Bus Operation table clarified (Table 2) Read/Reset , Auto Select and Multiple Word Program commands clarified
29-Nov-2002	5.4	90ns speed class obtained from the 100ns at $V_{CC} = 3.0$ to $3.6V$ - clarification (Table 11 and 12)
20-Feb-2003	5.5	TSOP Connections diagram updated (Figure 6)
05-Mar-2003	5.6	Typing error on page 1 corrected

Information furnished is believed to be accurate and reliable. However, STMicroelectronics assumes no responsibility for the consequences of use of such information nor for any infringement of patents or other rights of third parties which may result from its use. No license is granted by implication or otherwise under any patent or patent rights of STMicroelectronics. Specifications mentioned in this publication are subject to change without notice. This publication supersedes and replaces all information previously supplied. STMicroelectronics products are not authorized for use as critical components in life support devices or systems without express written approval of STMicroelectronics.

The ST logo is a registered trademark of STMicroelectronics  
FlexibleROM is a pending trademark of STMicroelectronics  
All other names are the property of their respective owners

© 2003 STMicroelectronics - All Rights Reserved

STMicroelectronics GROUP OF COMPANIES

Australia - Brazil - Canada - China - Finland - France - Germany - Hong Kong - India - Israel - Italy - Japan - Malaysia - Malta -  
Morocco - Singapore - Spain - Sweden - Switzerland - United Kingdom - United States

[www.st.com](http://www.st.com)