



SANYO Semiconductors DATA SHEET

LB8648T — Monolithic Digital IC DSC Driver

Feature and functions

- Actuator driver for digital cameras embedded in one chip
 1. Constant current control for AF (auto focus) Stepping motor × 1
→ 1-2 phase, 2 phase excitation possible.
 2. Constant current control for SH (shutter)/AE (aperture) VCM (Voice Coil Motor) × 2
→ SH implements start-up/falling correction circuit.
 3. Constant voltage control for ZOOM DC motor × 1
→ Operation by direct battery connection.
- Stand-by current consumed is 0 (zero).
- 2 power source systems (direct source connection, DC/DC systems)
- Large working voltage range (2.2 to 9V).
- Low saturation output
- Built-in overheat protection circuitry

Absolute Maximum Ratings at $T_a = 25^\circ\text{C}$

Parameter	Symbol	Conditions	Ratings	Unit
Max. Power Source Voltage	VB max	VB	10.5	V
	V _{CC} max	V _{CC}	10.5	
Max. Input Applied Voltage	V _{IN} max	MD1, MD2, MD3, IN1, IN2, INA, INB	10.5	V
Max. Output Applied Voltage	V _{OUT} max	OUT1, OUT2, OUT3, OUT4, OUT5, OUT6	10.5	V
Max. Output Current	I _O max	per CH	600	mA
Allowable Power Consumption	Pd max1	Circuit board mounting (*1)	1000	mW
Operating Temperature	Topr1		-20 to +80	°C
Storage Temperature	Tstg		-55 to +150	°C

(*1) Standard mounting circuit board : 76.1mm × 114.3mm × 1.6mm glass epoxy resin

- Any and all SANYO products described or contained herein do not have specifications that can handle applications that require extremely high levels of reliability, such as life-support systems, aircraft's control systems, or other applications whose failure can be reasonably expected to result in serious physical and/or material damage. Consult with your SANYO representative nearest you before using any SANYO products described or contained herein in such applications.
- SANYO assumes no responsibility for equipment failures that result from using products at values that exceed, even momentarily, rated values (such as maximum ratings, operating condition ranges, or other parameters) listed in products specifications of any and all SANYO products described or contained herein.

LB8648T

Allowable Operating Range at Ta = 25°C

Parameter	Symbol	Conditions	Ratings	Unit
Source Voltage Range	VB	(*2)	2.2 to 10	V
	V _{CC}		2.2 to 10	
Input Pin "H" Voltage	V _{INH}		1.8 to 10	V
Input Pin "L" Voltage	V _{INL}		-0.3 to 0.4	V
Constant Voltage Setting Input Range	VOC	VDC	0.8 to 2.0	V
Constant Current Setting Input Range	VO1	IAF, IAE, ISH	0.1 to 1.0	V

(*2) No restriction on priority among applied voltages of VB (Battery power supply), V_{CC} (step-up power supply) and V_{IN} (CPU power supply)
 Example1 : VB = 3.3V, V_{CC} = 4.0V, V_{IN} = 5.0V
 Example2 : VB = 3.3V, V_{IN} = 5.0V

Electrical Characteristics at Ta = 25°C, VB = V_{CC} = 3V, Rf = 1Ω

Parameter	Symbol	Conditions	Ratings			Unit
			min	typ	max	
Standby Current Consumption	I _{CC0}	VB = V _{CC} = 8.0V		0.1	5.0	μA
V _{CC} Operating Current Consumption	I _{CC1}	MD1/MD2 = H/L (AF 2 phase excitation mode)		18	24	mA
	I _{CC2}	MD1/MD2 = H/H (AF 1 phase excitation mode)		9	12	
	I _{CC3}	MD1/MD2 = L/H (SH/AE mode)		9	12	
	I _{CC4}	INA or INB = H (ZOOM mode)		9	12	
VB Operating Current Consumption	IB1	INA or INB = H (ZOOM mode)		12	16	mA
	IB2	Other mode		5	7	
Reference Voltage	V _{ref}	I _{ref} = -1mA	1.24	1.28	1.32	V
Reference Voltage Start-up Time	t _r	* Design guaranteed		0.5	2.0	μs
Input Pin Current	I _{IN}	V _{IN} = 5.0V		70	90	μA
Overheat Protection Detection Temperature	THD	* Design guaranteed (*3)	160	180	200	°C
[Constant current stepping motor driver for AF/STP] (OUT1, 2, 4, 5)						
Output Constant Current 1	I _{O11}	V _{CC} = 3.0 to 3.7V, Rf = 1Ω, IAF = 0.2V, MD1/MD2 = H/H (1 phase excitation mode)	188	200	212	mA
	I _{O12}	V _{CC} = 3.0 to 3.7V, Rf = 1Ω, IAF = 0.2V, MD1/MD2 = H/L (2 phase excitation mode)	122	130	138	
Output Saturation Voltage 1	VSAT1	V _{CC} = 3.3V, I _O = 0.2A (upper and lower)		0.25	0.38	V
[AE driver] (OUT5, 6)						
Output Constant Current 2	I _{O2}	V _{CC} = 3.0 to 3.7V, Rf = 1Ω, IAF = 0.2V	188	200	212	mA
Output Saturation Voltage 2	VSAT2	V _{CC} = 3.3V, I _O = 0.2A (upper and lower)		0.25	0.38	V
[SH driver] (OUT3, 2)						
Output Constant Current 3	I _{O3}	V _{CC} = 3.0 to 3.7V, Rf = 1Ω, ISH = 0.3V	282	300	318	mA
Output Saturation Voltage 3	VSAT3	V _{CC} = 3.3V, I _O = 0.3A (upper and lower)		0.4	0.58	V
[DC motor driver for ZOOM] (OUTA, B)						
Output Constant Voltage	V _O	VB = 3.0 to 3.7V, VDC = 1.0V	2.4	2.5	2.6	V
Output Saturation Voltage 4	VSAT4	VB = 3.3V, I _O = 0.4A (upper and lower)		0.5	0.7	V

(*3) For the characteristic within the guaranteed temperature range, shipment check is performed at Ta = 25°C.
 For all temperature range, it is design guaranteed.

LB8648T

Package Dimensions

unit : mm
3257

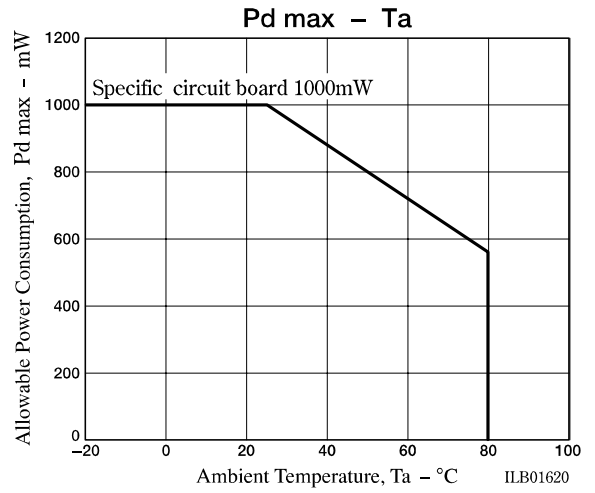
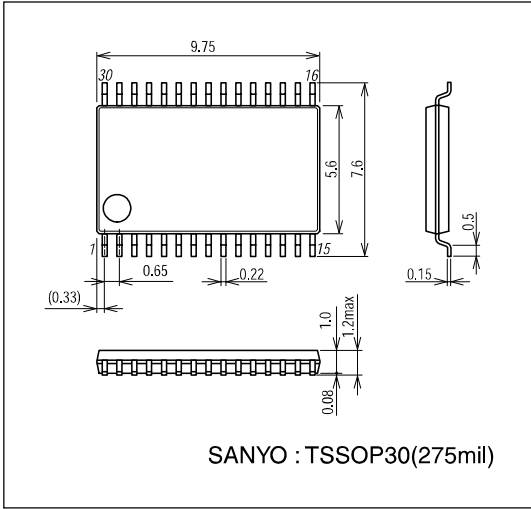

Pin Assignment

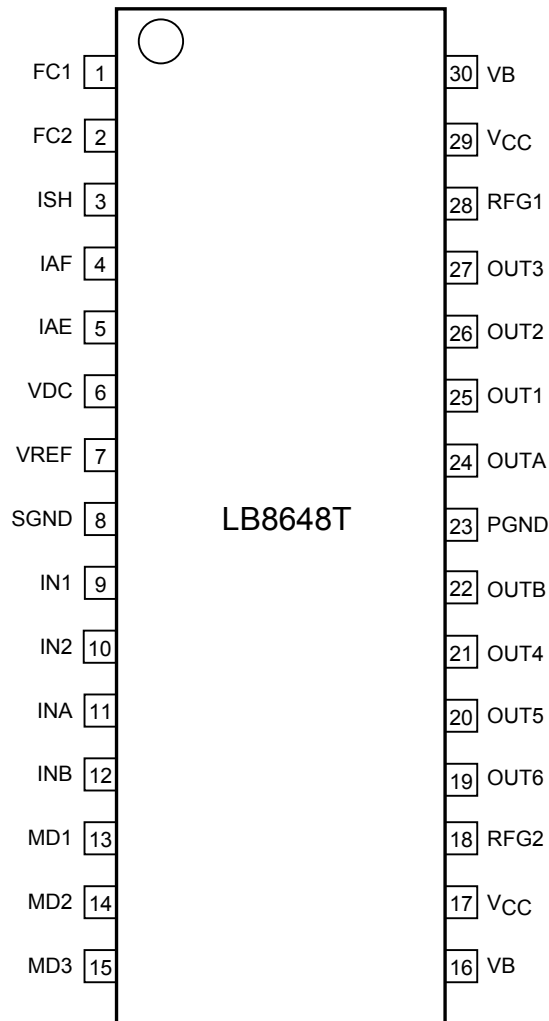

Top view

ILB01595

Note) VCC and VB, both 2 pins are connected.

Truth Table

1. DC motor constant voltage control for ZOOM

Input		Output		VREF	Mode
INA	INB	OUTA	OUTB		
L	L	-	-	-	Stand-by
H	L	H	L	ON	Normal rotation
L	H	L	H		Reverse rotation
H	H	H	H		Brake

“-” : High impedance

Note) When setting “H” for output, the output voltage is 2.5 times the VDC input voltage.

2. AF/SH/AE constant current control

Input					Output						VREF	ISH charge	Mode	
MD1	MD2	MD3	IN1	IN2	OUT1	OUT2	OUT3	OUT4	OUT5	OUT6				
L	L	L	L	L	-	-	-	-	-	-	-	-	-	Stand-by
H	L	L	*	*	-	-	-	-	-	-	ON	Discharge (*5)	Output suspended	
		H	L	L	L	H	-	H	L	-			AF (2 phase excitation) (*4)	
			H	L	H	L	-	H	L	-				
			H	H	H	L	-	L	H	-				
H	H	L	*	*	-	-	-	-	-	-			Output suspended	
		H	L	L	-	-	-	H	L	-			AF (1 phase excitation)	
			H	L	H	L	-	-	-	-				
			H	H	-	-	-	L	H	-				
L	H	H	*	L	-	-	-	-	L	H				
				H	-	-	-	-	H	L				
		L	L	*	L	-	H	L	-	-			-	
					H	-	L	H	-	-			-	

(*): Don't care. (-) : High impedance

(*4) When 2 phase excitation driving, the current becomes 65% of the setting current for 1 phase excitation driving.

Note) For stepping motor drive in AF mode, 1 phase, 2 phase and 1-2 phase excitation are possible.

(*5) The electric charge of start-up correction capacitor connected to ISH pin is discharged at the transistor inside.

Note) By connecting a capacitor to the ISH input pin, the start-up of constant current reference voltage is used and start-up waves of the coil current are suppressed.

By doing this, unstable shutter operation caused by the power supply voltage variations can be prevented.

Application Design Notes

1. Constant current setting (ISH, IAE, IAF, RFG1/2, OUT1 to 6)

The constant current setting between pins OUT2 and OUT3 in SH mode (MD1/2/3 = L/H/L) is determined from the ISH input voltage and the connecting resistor of RFG1. It is controlled in such a way so that the voltage generated at the resistor used for current detection connected between RFG1 and GND would be equal to the ISH input voltage, as for the circuit. The formula for calculating the output current is as given below.

$$(OUT2 \text{ to } OUT3 \text{ Output Current}) = (ISH \text{ Input Voltage}) \div (RFG1 \text{ Resistor})$$

In the same way, the constant current setting between pins OUT5 and OUT6 in AE mode (MD1/2/3 = L/H/H) is determined from the IAE input voltage and the connecting resistor of RFG2.

Also, the constant current setting between pins OUT1 and OUT2 and between pins OUT4 and OUT5 in AF mode (MD1/2/3 = H/L/H or H/H/H) is determined from the IAF input voltage and the connecting resistor of RFG1 or RFG2, respectively.

Furthermore, as the constant current control block within the IC is connected to SGND, when supplying voltage to the ISH pin or IAE pin which has been divided by resistors be sure to connect the ground side of these resistors to SGND.

2. Quick charge/discharge circuitry (FC1, OUT2 to 3)

Quick recharge and quick discharge circuitry has been built in to the shutter control block (OUT2 to OUT3) to support high-speed shutter control (consecutive shots).

Quick recharge and quick discharge circuitry has not been built in to the AF control block (OUT5 to OUT6) and the AF control block (OUT1 to OUT2, OUT4 to OUT5). Therefore, be sure to use the block (OUT2 to OUT3) for the shutter drive.

3. Start-up correction function (ISH, OUT2 to 3)

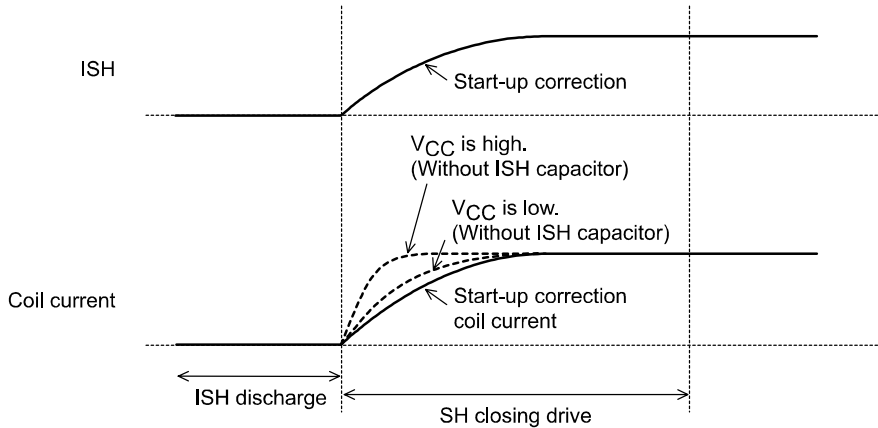

The ISH pin input voltage is set with the decay time constant by using the external CR. By setting the voltage to be lower than the coil decay time constant, the start-up wave of coil current is determined from the decay time constant of the external CR. By doing this, stable shutter operation can be carried out with respect to the power supply variations.

Note) For the ISH pin start-up correction, check the coil current start-up wave for the V_{CC} reduced voltage when there is no ISH pin capacitor and choose a capacitance so that the decay time constant is lower than this wave.

However, when the power supply voltage is stable or the start-up correction function is not required, the start-up correction capacitor is not necessary.

4. Phase compensation capacitor (FC1, FC2)

See and check the capacitor value for FC1 and FC2 between 0.0015 to 0.033 μ F. Choose a capacitance value which does not cause oscillation problems for output.

In particular, when a coil with large inductance is used, it is necessary to choose a sufficiently large capacitance.

Also, as the constant current control block within the IC is connected to SGND, be sure to connect the ground side of the FC1 pin and FC2 pin capacitor to SGND.

(Cautions with Regard to Selection of the FC1 and FC2 Capacitor Value)

FC1 is a connection pin for the phase compensation capacitor of the OUT1 to OUT3 output constant current control circuit. In the same way, FC2 is a connection pin for the phase compensation capacitor of the OUT4 to OUT6 output constant current control circuit.

The method by which the capacitor value is selected is to observe the output voltage wave and choose a value at which the output does not oscillate.

As for the circuit, the FC pin is connected to the output part of the constant current control amp, and the output transistor is driven from rises in the FC pin electric potential. That is to say, the FC pin initial state affects the output drive timing. Therefore, so as the FC pin state is always constant when driving the shutter, before passing current through the shutter the electric potential of the FC pin is discharged to a certain level within the IC (quick discharge circuit), and when current starts to pass through the shutter the FC pin electric potential is charged up to a certain level within the IC (quick charge circuit). As a result, the input/output delay time is stabilized.

However, if the capacitor value is too large, the charge/discharge time of the circuits above become long. This leads to large variations in the input/output delay times due to variations in the capacitor value (absolute value variations, temperature characteristics, etc).

There is another adverse effect of making the capacitor value large. That is, the coil current start-up gradient becomes gradual. The coil current start-up gradient should be determined by the coil's L component. However, if the capacitor value becomes large to the point that the capacitor decay time constant becomes larger, the coil current start-up gradient will come to depend on the capacitor value.

(When using by such setting of constant value, choose a capacitor of which temperature characteristic is flat as a capacitor to be connected.)

Given what is mentioned above, it is recommended that the smallest possible value for the capacitor connected to the FC pin be selected which prevents output oscillation (between 0.0015 μ F and 0.033 μ F), especially for applications which require a high-speed shutter driver.

5. Constant voltage control Oscillation-stopping capacitor (OUTA to B)

When controlling the constant voltages, it is necessary to place capacitors between the OUT pins to stop oscillation.

See and check the capacitor value between 0.01 μ F to 0.1 μ F. Choose a capacitor value which does not cause oscillation problems for output. When driving at saturation, there is no need for such oscillation-stopping capacitors.

Block Diagram

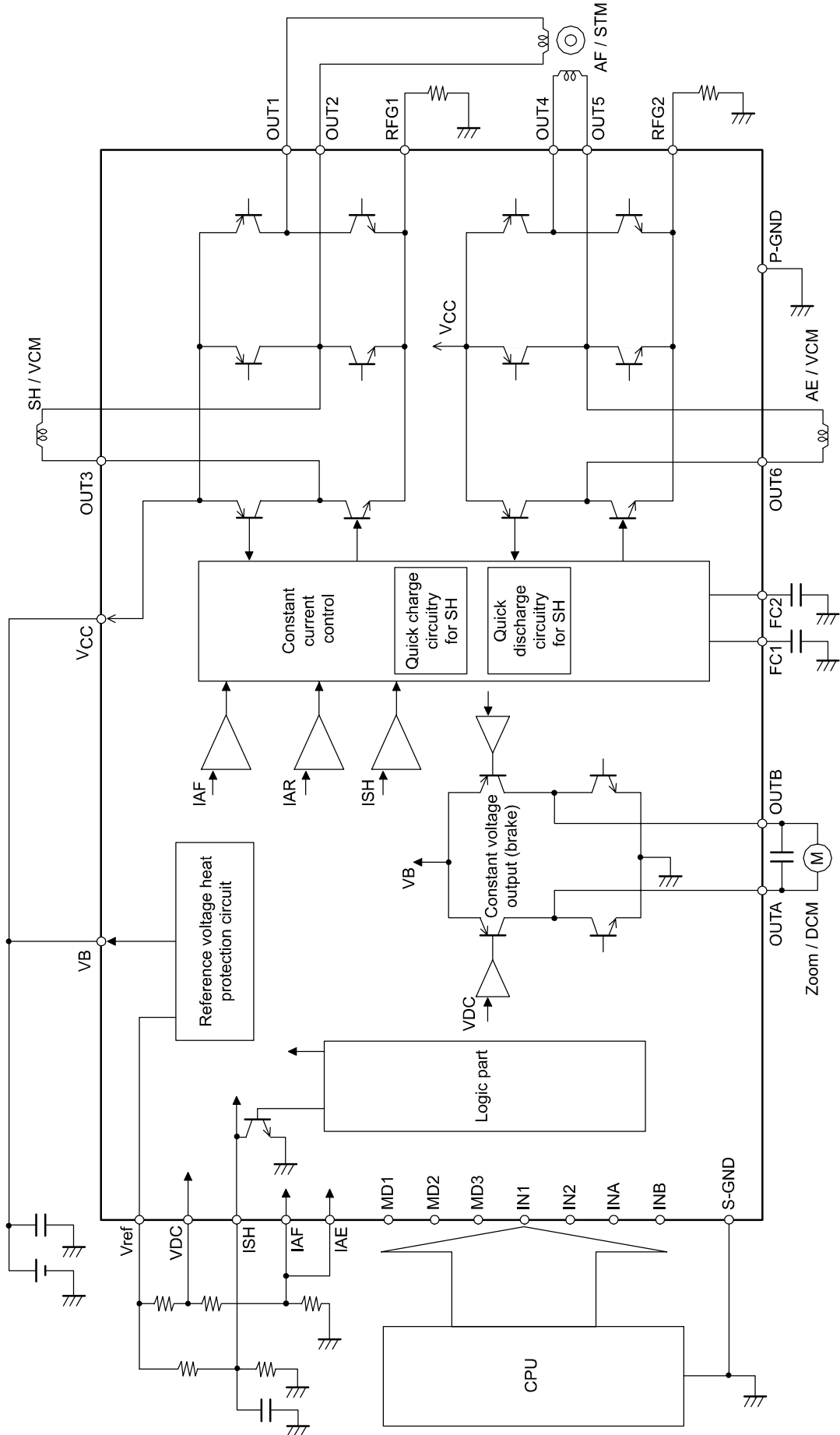

ILB01619

- Specifications of any and all SANYO products described or contained herein stipulate the performance, characteristics, and functions of the described products in the independent state, and are not guarantees of the performance, characteristics, and functions of the described products as mounted in the customer's products or equipment. To verify symptoms and states that cannot be evaluated in an independent device, the customer should always evaluate and test devices mounted in the customer's products or equipment.
- SANYO Electric Co., Ltd. strives to supply high-quality high-reliability products. However, any and all semiconductor products fail with some probability. It is possible that these probabilistic failures could give rise to accidents or events that could endanger human lives, that could give rise to smoke or fire, or that could cause damage to other property. When designing equipment, adopt safety measures so that these kinds of accidents or events cannot occur. Such measures include but are not limited to protective circuits and error prevention circuits for safe design, redundant design, and structural design.
- In the event that any or all SANYO products(including technical data, services) described or contained herein are controlled under any of applicable local export control laws and regulations, such products must not be exported without obtaining the export license from the authorities concerned in accordance with the above law.
- No part of this publication may be reproduced or transmitted in any form or by any means, electronic or mechanical, including photocopying and recording, or any information storage or retrieval system, or otherwise, without the prior written permission of SANYO Electric Co., Ltd.
- Any and all information described or contained herein are subject to change without notice due to product/technology improvement, etc. When designing equipment, refer to the "Delivery Specification" for the SANYO product that you intend to use.
- Information (including circuit diagrams and circuit parameters) herein is for example only ; it is not guaranteed for volume production. SANYO believes information herein is accurate and reliable, but no guarantees are made or implied regarding its use or any infringements of intellectual property rights or other rights of third parties.

This catalog provides information as of August, 2004. Specifications and information herein are subject to change without notice.