





HDSL TRANSFORMERS

For Brooktree and Level One Chipsets



-  Designs exceed standards for ANSI and ETSI
-  Excellent THD performance
-  Maximum height .500" (12,70 mm)
-  Matched to Brooktree's ICs

Electrical Specifications @ 25°C — Operating Temperature -40°C to 85°C

Part Number	Matched To Brooktree IC No.	Application	Turns Ratio Chip-Line (±2%)	Inductance Line Side (mH)	DC Current Capability (mA)	Leakage Inductance (µH MAX)	Isolation Voltage (Vrms MIN)	Mounting
PE-68621	BT8952	784 Kbps (2 pair)	2CT:1:1	3.0 ± 6%	160	16	1500	THT
PE-68622	BT8952	1168 Kbps (2 pair)	2CT:1:1	2.0 ± 6%	160	16	1500	THT
PE-69300	BT8921/BT8970	784 Kbps (2 pair)	1CT:1:1	3.0 ± 6%	70	8	1500	THT
PE-69301	BT8921/BT8970	1168 Kbps (2 pair)	1CT:1:1	2.0 ± 6%	70	8	1500	THT
B1001	BT8960	416 Kbps	1CT:1:1	3.5 ± 10%	70	12	1500	THT
B1002	BT8960	288 Kbps	1CT:1:1	5.0 ± 10%	70	12	1500	THT
B1004	BT8960	160 Kbps	1CT:1:1	8.0 ± 10%	70	16	1500	THT
B1006	BT8921/BT8970	1168 Kbps (2 pair)	1CT:1:1	2.0 ± 6%	70	8	1500	SMT
B1007	BT8921/BT8970	784 Kbps (2 pair)	1CT:1:1	3.0 ± 6%	70	8	1500	SMT

Additional Information

Part Number	DCR Line Side (MAX)	DCR Chip Side (MAX)	Return Loss			Longitudinal Balance (dB TYP @ 135 Ω)	THD (dB TYP @ 135 Ω)	Mounting
			4 KHz - 2 MHz	40 - 200 KHz	40 - 320 KHz			
PE-68621	2.2 Ω (6-7),(8-9)	4.4 Ω (2-4)	4 dB MIN	20 dB MIN	—	55 @ 196 KHz	-75 @ 200 KHz, 6V p-p	THT
PE-68622	2.2 Ω (6-7),(8-9)	4.4 Ω (2-4)	4 dB MIN	—	16.5 dB MIN	55 @ 292 KHz	-75 @ 200 KHz, 6V p-p	THT
PE-69300	2.2 Ω (6-7),(8-9)	2.2 Ω (2-4)	4 dB MIN	20 dB MIN	—	55 @ 196 KHz	-75 @ 200 KHz, 6V p-p	THT
PE-69301	2.2 Ω (6-7),(8-9)	2.2 Ω (2-4)	4 dB MIN	—	16.5 dB MIN	55 @ 292 KHz	-75 @ 200 KHz, 6V p-p	THT
B1006	2.2 Ω (6-7),(8-9)	2.2 Ω (2-4)	4 dB MIN	—	16.5 dB MIN	55 @ 292 KHz	-75 @ 200 KHz, 6V p-p	SMT
B1007	2.2 Ω (6-7),(8-9)	2.2 Ω (2-4)	4 dB MIN	20 dB MIN	—	55 @ 196 KHz	-75 @ 200 KHz, 6V p-p	SMT
			9 - 40 KHz	20 - 80 KHz	33 - 110 KHz			
B1001	2.2 Ω (6-7),(8-9)	2.2 Ω (2-4)	—	—	16.5 dB MIN	55 @ 104 KHz	-70 @ 104 KHz, 6V p-p	THT
B1002	2.5 Ω (6-7),(8-9)	2.5 Ω (2-4)	—	16.5 dB MIN	—	55 @ 72 KHz	-70 @ 80 KHz, 6V p-p	THT
B1004	3.0 Ω (6-7),(8-9)	3.0 Ω (2-4)	16.5 dB MIN	—	—	55 @ 40 KHz	-70 @ 40 KHz, 6V p-p	THT

Surge Voltage Capability: Metallic: 800 Vpeak 10/560 µsec. Long.: 2400 Vpeak 10/700 µsec. UL approval for basic insulation has been received (File: E133523).

Mechanicals

Schematic

THT

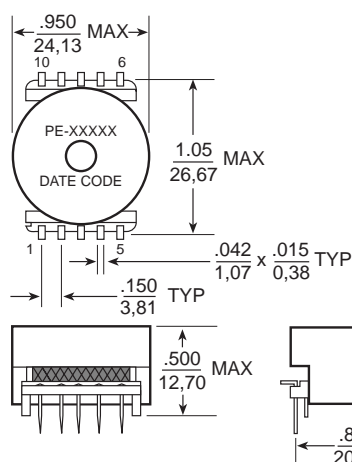

SMT

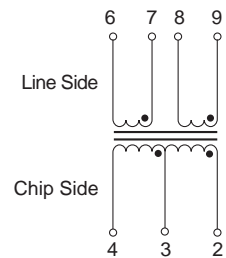
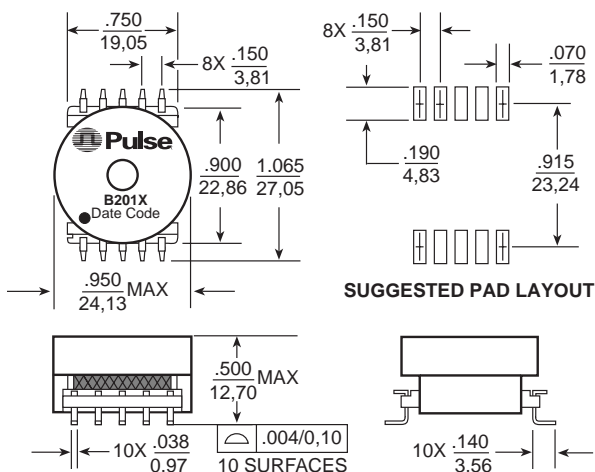





Weight.....14.0 grams
 Tray.....45/tray
 Dimensions: $\frac{\text{Inches}}{\text{mm}}$
 Unless otherwise specified,
 all tolerances are $\pm .010$
 0,25

HDSL TRANSFORMERS

For Brooktree and Level One Chipsets



-  Designs exceed standards for ANSI and ETSI
-  Excellent THD performance
-  Maximum height .500" (12,7 mm)
-  Matched to Level One's ICs

Electrical Specifications @ 25°C — Operating Temperature -40°C to 85°C

Part Number	Matched To Level One IC No.	Application (Kbps)	Turns Ratio Chip-Line ($\pm 3\%$)	Inductance Line Side (mH)	DC Current Capability (mA)	Leakage Inductance (MAX)	Isolation Voltage (Vrms MIN)
PE-68614*	SK70704	784 (2 pair)	1CT:1.8CT	2.75 \pm 6%	75	—	2000
PE-68650	SK70704	1168 (2 pair)	1CT:1.8CTS	2.06 \pm 6%	75	—	2500

Additional Information

Part Number	DCR Line Side (Ω MAX)	DCR Chip Side (Ω MAX)	Return Loss			Longitudinal Balance (dB MIN @ 135 Ω)	THD (dB TYP @ 135 Ω)
			4 KHz - 2 MHz	40 - 200 KHz	40 - 320 KHz		
PE-68614	3.0 (6-8),(8-10)	3.2 (2-4)	—	20 dB MIN	—	50 @ 5-196 KHz	-75 (5 KHz, 6 V p-p)
PE-68650	2.0 (6-7),(9-10)	2.0 (2-4)	—	—	16.5 dB MIN	50 @ 5-292 KHz	-75 (5 KHz, 6 V p-p)

Surge Voltage Capability: Metallic: 800 Vpeak 10/560 μ sec. Long.: 2400 Vpeak 10/700 μ sec. UL approval for basic insulation has been received (File: E133523).

Mechanical

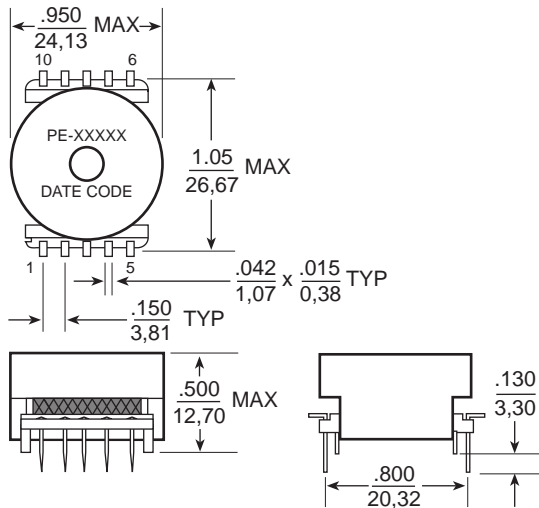

Schematic

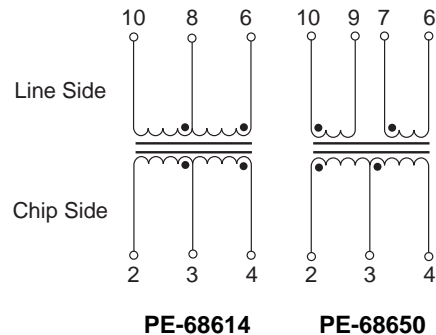

Weight14.0 grams
Tray45/tray

Dimensions: Inches
mm

Unless otherwise specified, all tolerances are $\pm \frac{.010}{.025}$

*The PE-68614 does not have standoffs and has a height of .450" (11,43 mm) MAX, and a leadlength of 0.125" \pm 0.030".

For More Information :

Corporate
12220 World Trade Drive
San Diego, CA 92128
Tel: 619 674 8100
FAX: 619 674 8262
http://www.pulseeng.com
Quick-Facts: 619 674 9672

Europe
Millpool House
Mill Lane, Godalming
Surrey GU7 1EY
U.K.
Tel: 441 483 428 877
FAX: 441 483 416 011

Asia
P.O. Box 26-11, KEPZ
6 Central Sixth Road
KEPZ, Kaohsiung
Taiwan, R.O.C.
Tel: 886 7 821 3141
FAX: 886 7 841 9707

Distributor

Performance warranty of products offered on this data sheet is limited to the parameters specified. Data is subject to change without notice. Other brand and product names mentioned herein may be trademarks or registered trademarks of their respective owners.