

System Reset Monolithic IC PST93XX Series

Outline

These low reset type ICs function in a variety of CPU systems and other logic systems, to detect power supply voltage and reset the system accurately when power is turned on or interrupted. They are ideal for use in battery check circuits for products using batteries, as they have ultra-low current consumption and a high precision voltage detection function.

Features

- | | |
|--|---|
| 1. High precision voltage detection | $V_s \pm 2\%$ max. |
| 2. Ultra-low current consumption | $I_{CCH} = 2.0\mu A$ typ. $I_{CCL} = 2.0\mu A$ typ. |
| 3. Low operating limit voltage | 0.65V typ. |
| 4. Hysteresis voltage provided in detection voltage | 50mV typ. |
| 5. Output current high for ON | 5mA min. |
| 6. Detection voltage can be selected as desired within a range of 1.9V ~ 4.6V in 0.1V steps, as indicated below. | |

PST93XX
detection voltage value
 (Example: for 4.2V PST9342)

Package

SC-82ABA (PST93XXU)

Applications

1. Reset circuits in microcomputers, CPUs and MPUs.
2. Logic circuit reset circuits.
3. Battery voltage check circuits.
4. Back-up power supply switching circuits.
5. Level detection circuits.

Pin Assignment

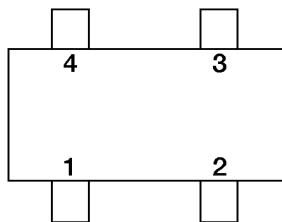

SC-82ABA

1	NC
2	GND
3	V_{OUT}
4	V_{CC}

Block Diagram

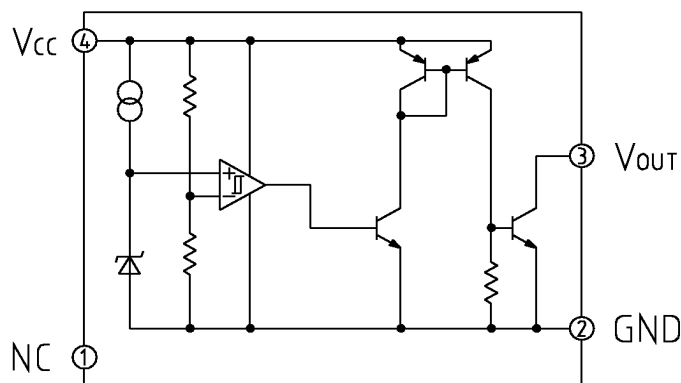

Pin Description

Pin no.	Pin name	Function
1	NC	
2	GND	GND pin
3	V _{OUT}	Reset signal output pin
4	V _{CC}	Power supply pin/voltage detection pin

Absolute Maximum Ratings (Ta=25°C)

Item	Symbol	Rating	Units
Storage temperature	T _{STG}	-40~+125	°C
Operating temperature	T _{OPR}	-20~+75	°C
Power supply voltage	V _{CC} max.	-0.3~10	V
Allowable loss	P _d	150	mW

Recommended Operating Conditions

Item	Symbol	Rating	Units
Operating temperature	T _{OPR}	-20~+75	°C
Power supply voltage	V _{CC}	+0.85~+10	V

Electrical Characteristics (Ta=25°C)

Item	Symbol	Measurement circuit	Measurement conditions	Min.	Typ.	Max.	Units	
Detection voltage	Vs	1	V _{CC} =H→L R _L =4.7kΩ V _{OL} ≤ 0.4V	PST9346	4.508	4.600	4.692	V
				PST9345	4.410	4.500	4.590	
				PST9344	4.312	4.400	4.488	
				PST9343	4.214	4.300	4.386	
				PST9342	4.116	4.200	4.284	
				PST9341	4.018	4.100	4.182	
				PST9340	3.920	4.000	4.080	
				PST9339	3.822	3.900	3.978	
				PST9338	3.724	3.800	3.876	
				PST9337	3.626	3.700	3.774	
				PST9336	3.528	3.600	3.672	
				PST9335	3.430	3.500	3.570	
				PST9334	3.332	3.400	3.468	
				PST9333	3.234	3.300	3.366	
				PST9332	3.136	3.200	3.264	
				PST9331	3.038	3.100	3.162	
				PST9330	2.940	3.000	3.060	
				PST9329	2.842	2.900	2.958	
				PST9328	2.744	2.800	2.856	
				PST9327	2.646	2.700	2.754	
PST9326	2.548	2.600	2.652					
PST9325	2.450	2.500	2.550					
PST9324	2.352	2.400	2.448					
PST9323	2.254	2.300	2.346					
PST9322	2.156	2.200	2.244					
PST9321	2.058	2.100	2.142					
PST9320	1.960	2.000	2.040					
PST9319	1.862	1.900	1.938					
Hysteresis voltage	ΔVs	1	V _{CC} =L→H→L, R _L =4.7kΩ	30	50	100	mV	
Detection voltage temperature coefficient	Vs/ΔT	1	R _L =4.7kΩ, Ta=-20~+75°C		±0.01		%/°C	
Low-level output voltage	V _{OL}	1	V _{CC} =Vs min.-0.05V, R _L =4.7kΩ		0.2	0.4	V	
Output leakage current	I _{OH}	1	V _{CC} =V _O =10V			±0.1	μA	
Circuit current while on	I _{CCL}	1	V _{CC} =Vs min.-0.05V, R _L =∞		2.0	4.0	μA	
Circuit current while off	I _{CCH}	1	V _{CC} =Vs typ./0.85, R _L =∞		2.0	4.0	μA	
"H"transport delay time	T _{PLH}	2	R _L =4.7kΩ, C _L =100pF *1		20	60	μS	
"L"transport delay time	T _{PHL}	2	R _L =4.7kΩ, C _L =100pF *2		20	60	μS	
Operation limit voltage	V _{OPL}	1	R _L =4.7kΩ, V _{OL} ≤ 0.4V		0.65	0.85	V	
Output current while on 1	I _{OL1}	1	V _{CC} =Vs min.-0.05V, V _O =0.4V	5			mA	
Output current while on 2	I _{OL2}	1	V _{CC} =Vs min.-0.05V, Ta=-20~+75°C	3			mA	

*1 : t_{PLH} : V_{CC}= (Vs typ.-0.4v)→(Vs typ.+0.4v)

*2 : t_{PHL} : V_{CC}= (Vs typ.+0.4v)→(Vs typ.-0.4v)

Measuring Circuit

(1)

S1=ON, S2=OFF : when measuring I_{OH} , I_{OL1} , I_{OL2}
 S1=OFF, S2=ON : for measuring other than the above

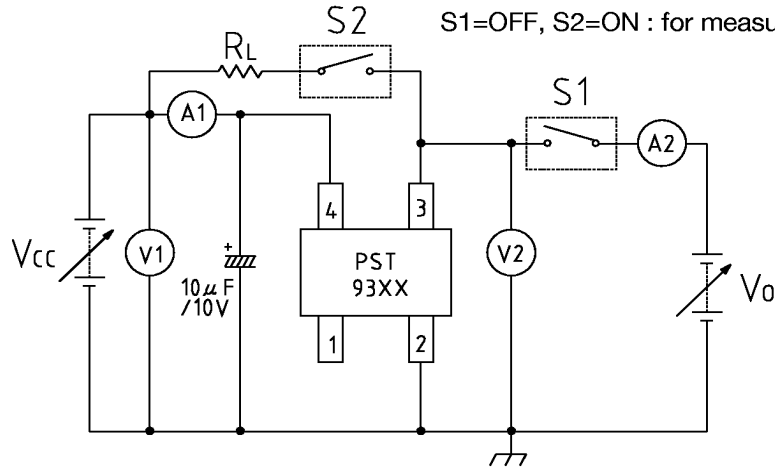

(2)

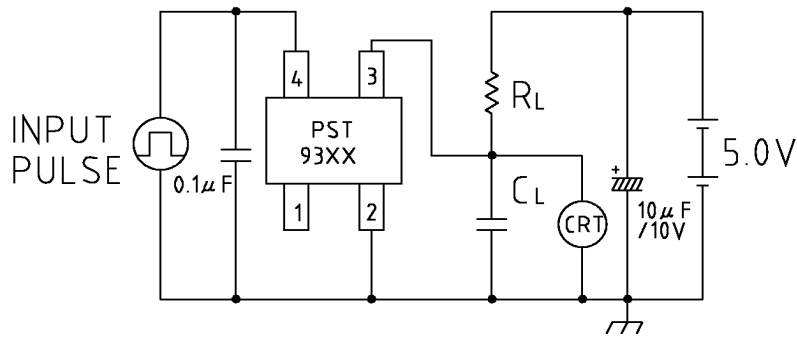

A : DC ammeter
 V : DC voltmeter
 CRT : Oscilloscope

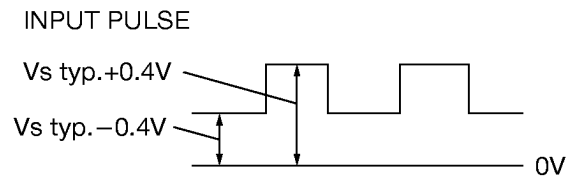

Application circuits

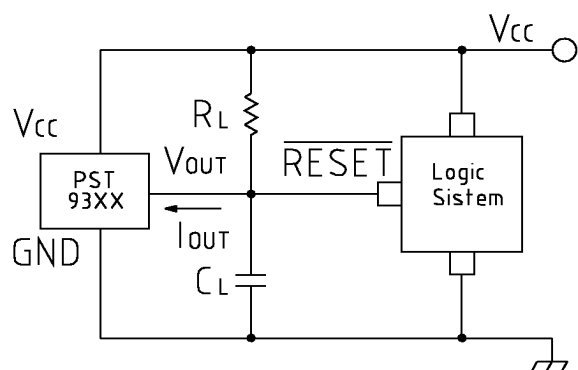

[CL setting]

Several tens of mV of oscillation may appear in V_{OUT} when V_{CC} is near operating limit (approx. 0.7V~1.0V, if R_L is set at more than $R_L \approx 500k\Omega$ * in the above application circuit. If this presents a problem, set the C_L value slightly higher (1000pF or more recommended).

*: Varies slightly depending on V_S rank.

Characteristics

