



ULTRAFAST, LOW SWITCHING LOSS RECTIFIER DIODE

DESCRIPTION

The UTC **BYC5-600** is a rectifier diode. It provides the designers with ultra-fast switching and low switching loss.

The UTC **BYC5-600** is suitable for half-bridge lighting ballasts, half-bridge/full-bridge switched mode power supplies and active power factor correction applications.

FEATURES

- * Low Reverse Recovery Current
- * Ultra-Fast Switching
- * Low Switching Loss
- * Low Thermal Resistance

SYMBOL

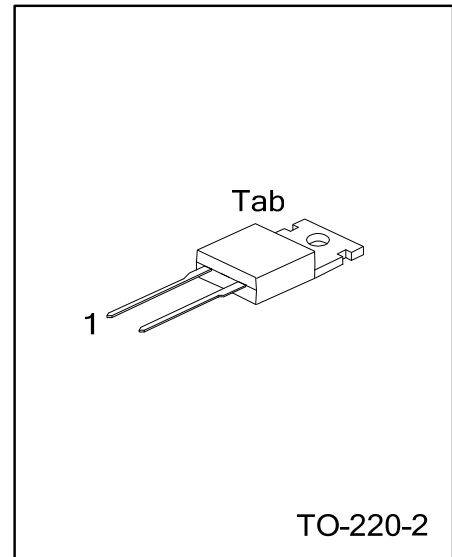
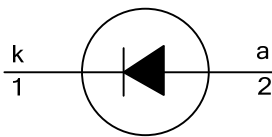

ORDERING INFORMATION

Ordering Number		Package	Pin Assignment			Packing
Lead Free Plating	Halogen Free		1	2	Tab	
BYC5L-600-TA2-T	BYC5G-600-TA2-T	TO-220-2	K	A	K	Tube

Note: Pin Assignment: A: Anode, K: Cathode, Tab: Mounting Base

<p>BYC5L-600-TA2-T</p> <p>(1)Packing Type</p> <p>(2)Package Type</p> <p>(3)Lead Free</p>	<p>(1) T: Tube</p> <p>(2) TA2: TO-220-2</p> <p>(3) L: Lead Free, G: Halogen Free</p>
--	--

■ ABSOLUTE MAXIMUM RATINGS

PARAMETER	SYMBOL	RATINGS	UNIT
Peak Repetitive Reverse Voltage	V_{RRM}	600	V
Crest Working Reverse Voltage	V_{RWM}	600	V
Continuous Reverse Voltage	V_R	500	V
Average Forward Current	$I_{F(AV)}$	5	A
Repetitive Peak Forward Current	I_{FRM}	10	A
Non-Repetitive Peak Forward Current	I_{FSM}	40	A
		44	A
Junction Temperature	T_J	150	°C
Storage Temperature	T_{STG}	-40 ~ +150	°C

Note: Absolute maximum ratings are those values beyond which the device could be permanently damaged.

Absolute maximum ratings are stress ratings only and functional device operation is not implied.

■ THERMAL DATA

PARAMETER	SYMBOL	RATINGS	UNIT
Junction to Ambient	θ_{JA}	60	K/W
Junction to Tab	θ_{JB}	2.5	K/W

■ ELECTRICAL CHARACTERISTICS ($T_J = 25^\circ\text{C}$, unless otherwise specified)

PARAMETER	SYMBOL	TEST CONDITIONS	MIN	TYP	MAX	UNIT	
Forward Voltage	V_F	$I_F = 5\text{A}, T_J = 150^\circ\text{C}$		1.4	1.75	V	
		$I_F = 10\text{A}, T_J = 150^\circ\text{C}$		1.75	2.2	V	
		$I_F = 5\text{A}$		2.0	2.9	V	
Reverse Current	I_R	$V_R = 600\text{V}$		9	100	μA	
		$V_R = 500\text{V}, T_J = 100^\circ\text{C}$		0.9	3.0	mA	
Reverse Recovery Time	t_{RR}	$I_F = 1\text{A}, V_R = 30\text{V}, dI_F/dt = 50\text{A}/\mu\text{s}$		30	50	ns	
		$I_F = 5\text{A}, V_R = 400\text{V}, dI_F/dt = 500\text{A}/\mu\text{s}$		19		ns	
Peak Reverse Recovery Current	I_{RRM}	$I_F = 5\text{A}, V_R = 400\text{V}, T_J = 125^\circ\text{C}$	$dI_F/dt = 50\text{A}/\mu\text{s}$		0.7	3	A
			$dI_F/dt = 500\text{A}/\mu\text{s}$		8	11	A
Forward Recovery Voltage	V_{FR}	$I_F = 10\text{A}, dI_F/dt = 100\text{A}/\mu\text{s}$		9	11	V	

■ TYPICAL CHARACTERISTICS

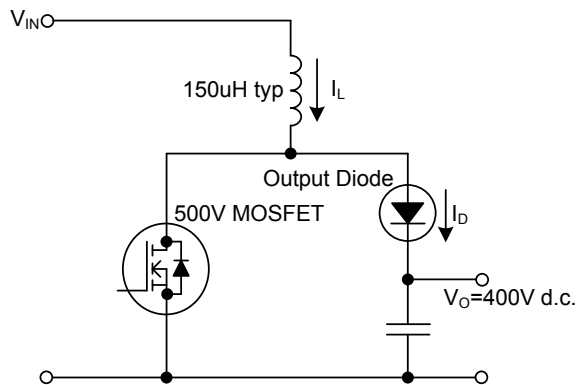

Fig.1. Typical application, output rectifier in boost converter power factor correction circuit. Continuous conduction mode, where the transistor turns on whilst forward current is still flowing in the diode.

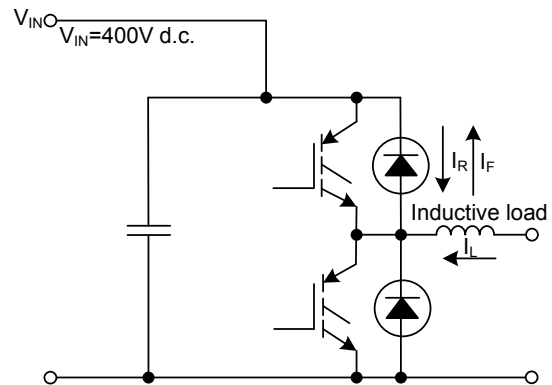

Fig.2. Typical application, freewheeling diode in half bridge converter. Continuous conduction mode, where each transistor turns on whilst forward current is still flowing in the other bridge leg diode.

UTC assumes no responsibility for equipment failures that result from using products at values that exceed, even momentarily, rated values (such as maximum ratings, operating condition ranges, or other parameters) listed in products specifications of any and all UTC products described or contained herein. UTC products are not designed for use in life support appliances, devices or systems where malfunction of these products can be reasonably expected to result in personal injury. Reproduction in whole or in part is prohibited without the prior written consent of the copyright owner. The information presented in this document does not form part of any quotation or contract, is believed to be accurate and reliable and may be changed without notice.