

---

# MSM7660

---

## Digital Video Decoder (NTSC/PAL Compatible)

---

### GENERAL DESCRIPTION

The MSM7660 is a decoder which converts digitally sampled NTSC or PAL video signals to the format based on ITU-RBT601.

The MSM7660 can accept composite video and S video signals.

For composite signals, the MSM7660 converts signals to YUV data via a 2-dimensional Y/C separation circuit. For S video signals, the MSM7660 converts signals to YUV data by passing the 2-dimensional Y/C separation circuit.

An internal AGC/ACC circuit makes decoding of images relatively easy.

Video signals are internally synchronized, so a relatively wide range of video signals can be decoded without using an external VCO circuit.

### FEATURES

- Accepts composite video and S video signals
- Compatible with NTSC/PAL
- 2-dimensional Y/C separation using adaptive comb filter (this filter is bypassed for S video signal input)
  - NTSC: 3 lines/2 lines
  - PAL: 2 lines
- Sampling frequency
  - 14.75 MHz (PAL Square Pixel)
  - 14.31818 MHz (NTSC 4Fsc)
  - 12.27 MHz (NTSC Square Pixel)
  - 13.5 MHz (ITU-RS601)
- Internal AGC/ACC circuit
- 8-bit Y/C (CbCr) output (conforms to ITU-RBT601)
  - YCbCr: 4:2:2
  - YCbCr: 4:1:1
- High impedance output possible, priority cascade control function
- I<sup>2</sup>C-BUS interface
- External terminal mode (default) or internal register mode can be selected for operation mode setting.
- A frequency one or two times the sampling clock is supplied to LSI
- Power consumption: 500 mW (Typ. 13.5 MHz)
- Package:
  - 80-pin plastic QFP (QFP80-P-1420-0.80-BK) (Product name: MSM7660GS-BK)

**BLOCK DIAGRAM**

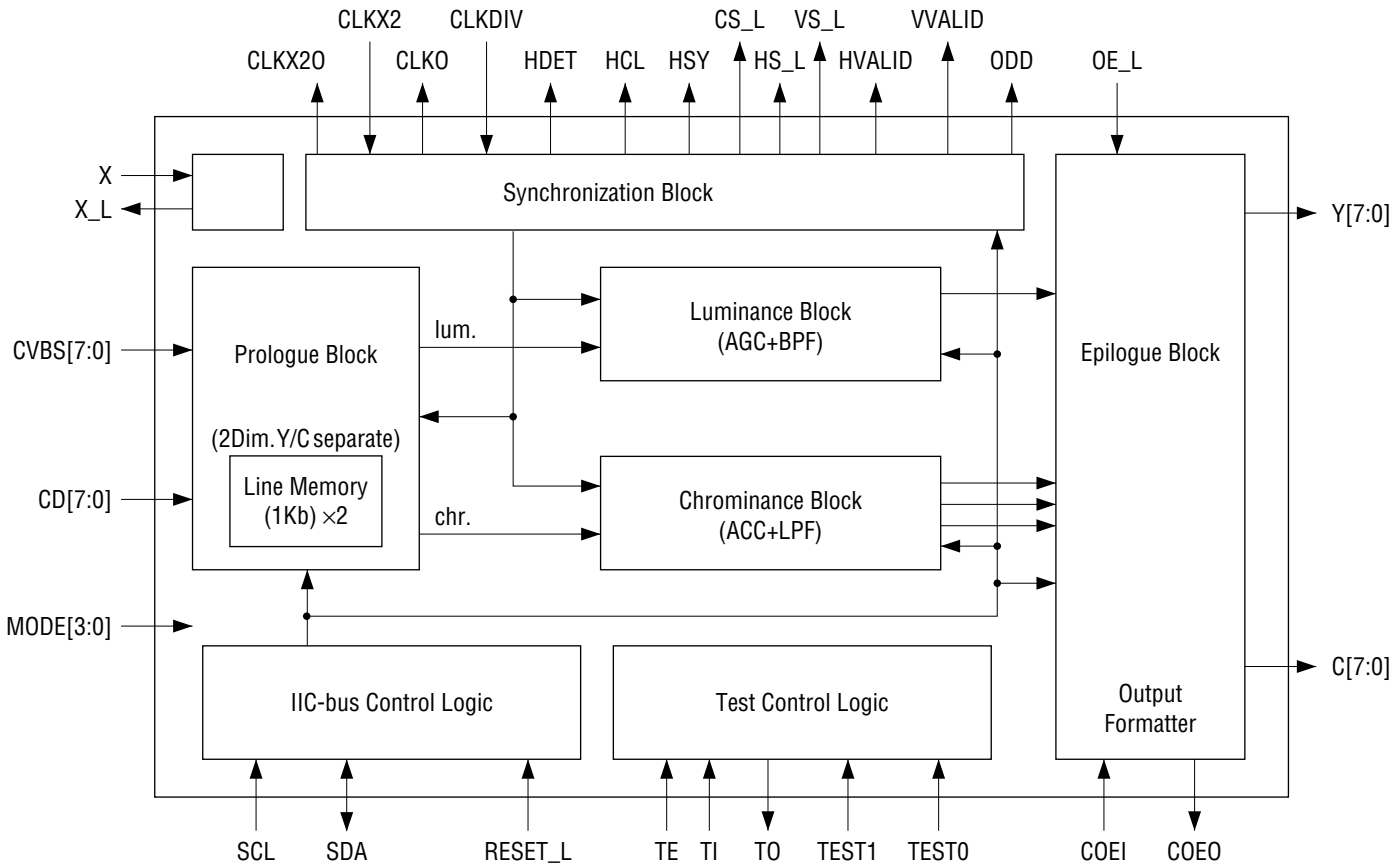

**PIN CONFIGURATION (TOP VIEW)**

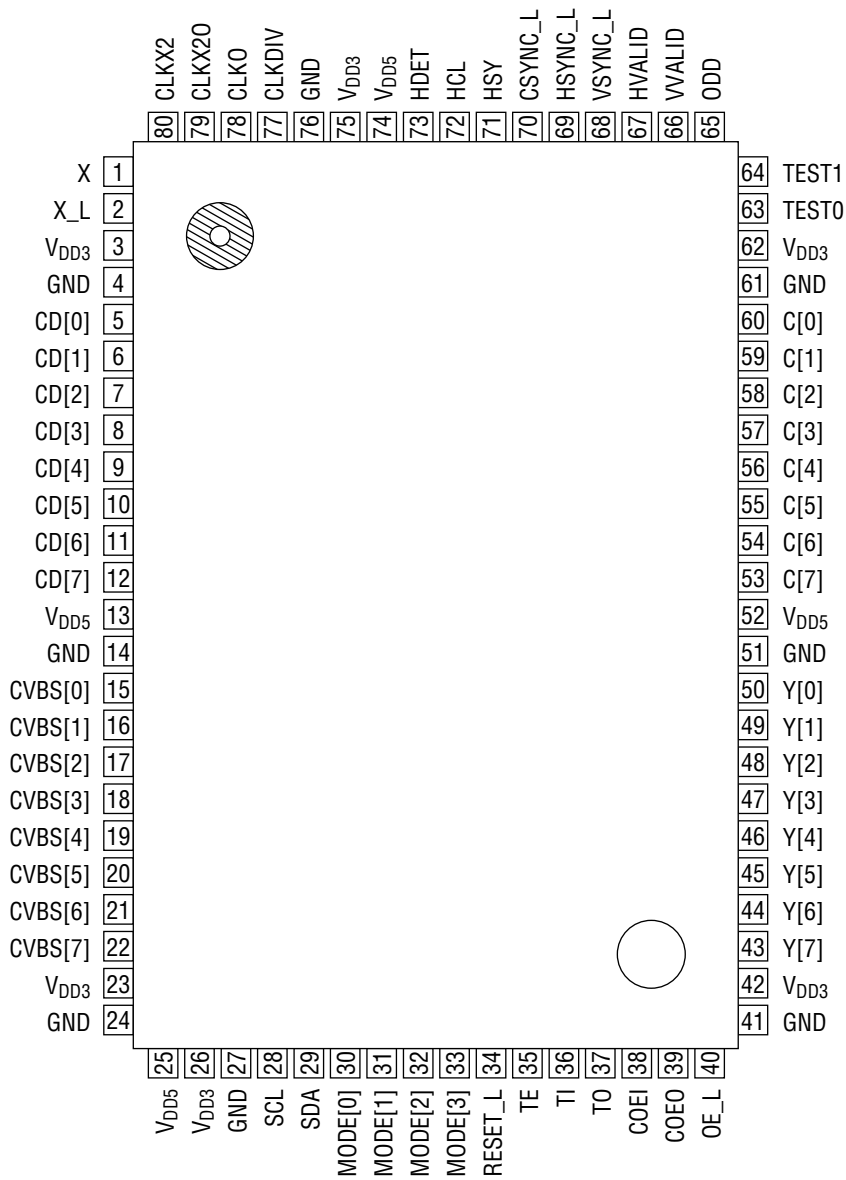

**80-Pin Plastic QFP**

## PIN DESCRIPTIONS

Pin	Symbol	I/O	Description
1	X	I	Test pin. Normally, to "L" level.
2	X_L	O	Unused pin.
3	V <sub>DD3</sub>		Internal logic power supply (3.3 V typ.)
4	GND		
5 to 12	CD[0 to 7]	I	Chrominance signal input pin (valid only for S video input) Set to "L" level at composite signal input
13	V <sub>DD5</sub>		Peripheral I/O power supply (5 V typ.)
14	GND		
15 to 22	CVBS[0 to 7]	I	Composite digital data input pin Luminance signal is input for S video input.
23	V <sub>DD3</sub>		Internal logic power supply (3.3 V typ.)
24	GND		
25	V <sub>DD5</sub>		Peripheral I/O power supply (5 V typ.)
26	V <sub>DD3</sub>		Internal logic power supply (3.3 V typ.)
27	GND		
28	SCL	I	I <sup>2</sup> C-bus clock pin
29	SDA	I/O	I <sup>2</sup> C-bus data pin
30 to 33	MODE[0 to 3]	I	Mode input pins. Dip switches can be used because these pins are internally pulled-up. MODE[3]    0: composite 1: S video MODE[2:0]   000: NTSC    ITU-RS601    13.5MHz 001: NTSC    Square Pixel 12.27 MHz 010: NTSC    4Fsc        14.32 MHz 100: PAL     ITU-RS601    13.5 MHz 101: PAL     Square Pixel 14.75 MH others:     Undefined
34	RESET_L	I	System reset input pin (active at "L")
35	TE	I	Test pin. Normally, set to "L" level
36	TI	I	Test pin. Normally, set to "L" level
37	TO	O	Test pin
38	COEI	I	Cascade priority control input pin Connected to COEO of decoder with higher priority.
39	COEO	O	Cascade priority control output pin Outputs "L" when COEI is "L" or when this LSI is in output enable status.
40	OE_L	I	Y/C/HSYNC-L/VSYNC-L output enable input pin (active at "L") OR condition with register setting
41	GND		
42	V <sub>DD3</sub>		Internal logic power supply (3.3 V typ.)

Pin	Symbol	I/O	Description
43 to 50	Y[7 to 0]	0	Luminance signal output pin
51	GND		
52	V <sub>DD5</sub>		Peripheral I/O power supply (5.0 V typ.)
53 to 60	C[7 to 0]	0	Chrominance signal output pin
61	GND		
62	V <sub>DD3</sub>		Internal logic power supply (3.3 V typ.)
63	TEST0	I	Input pin for testing. Normally use this pin at open state or "H" level.
64	TEST1	I	Input pin for testing. Normally use this pin at open state or "H" level.
65	ODD	0	Field display output pin Outputs "H" for odd field.
66	VVALID	0	Vertical valid line timing output pin
67	HVALID	0	Horizontal valid pixel timing output pin
68	VSYNC_L	0	V sync output pin
69	HSYNC_L	0	H sync output pin
70	CSYNC_L	0	Composite sync output pin
71	HSY	0	Sync chip timing output pin for AD converter
72	HCL	0	Clamp timing output pin for AD converter
73	HDET	0	HLOCK synchronization detection display output pin (Outputs "H" when H synchronization is established.)
74	V <sub>DD5</sub>		Peripheral I/O power supply (5.0 V typ.)
75	V <sub>DD3</sub>		Internal logic power supply (3.3 V typ.)
76	GND		
77	CLKDIV	I	Clock select input pin Inputs "H" when a half CLKX2 is used as the internal clock.
78	CLKO	0	Clock output pin Outputs internal clock.
79	CLKX20	0	Clock output pin Bypasses clock input and outputs clock input.
80	CLKX2	I	Clock input pin (a clock one or two times the sampling clock is input)

[Clock supply method and handling]

1. Supplying double pixel clock from external supply source

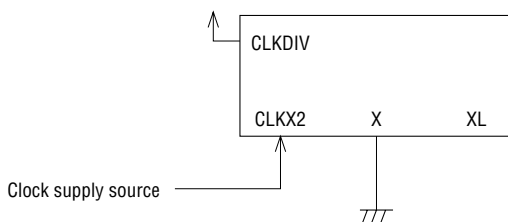

2. Supplying pixel clock from external supply source

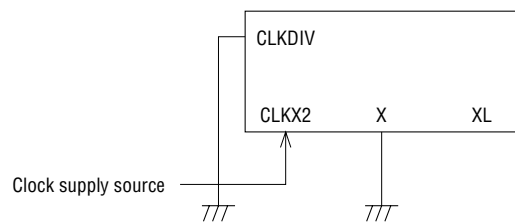

**ABSOLUTE MAXIMUM RATINGS**

Parameter	Symbol	Condition	Rating	Unit
Power Supply Voltage	$V_{DD5}$	$T_a=25^{\circ}\text{C}$	-0.3 to +7	V
	$V_{DD3}$	$T_a=25^{\circ}\text{C}$	-0.3 to +4.5	
Input Voltage	$V_I$	$T_a=25^{\circ}\text{C}$	-0.3 to $V_{DD5} + 0.3$	V
Power Consumption	$P_W$	—	800	mW
Storage Temperature	$T_{STG}$	—	-55 to +150	$^{\circ}\text{C}$

**RECOMMENDED OPERATING CONDITIONS**

Parameter	Symbol	Condition	Min.	Typ.	Max.	Unit
Power Supply Voltage	$V_{DD5}$	$T_a=25^{\circ}\text{C}$	4.5	5.0	5.5	V
	$V_{DD3}$	$T_a=25^{\circ}\text{C}$	3.0	3.3	3.6	
Power Supply Voltage	GND	$T_a=25^{\circ}\text{C}$	—	0.0	—	V
High Level Input Voltage	$V_{IH1}$	—	2.2	—	$V_{DD5}$	V
High Level Input Voltage	$V_{IH2} (*1)$	—	$0.8V_{DD5}$	—	$V_{DD5}$	V
Low Level Input Voltage	$V_{IL}$	—	0.0	—	0.8	V
Operating Temperature Range	$T_a$	—	0	—	70	$^{\circ}\text{C}$

\*1: CCKX2, CLKDIV, SDA

**ELECTRICAL CHARACTERISTICS**

**DC Characteristics**

(Ta=0 to 70°C, VDD3=3.3V±0.3V, VDD5=5V±10%)

Parameter	Symbol	Condition	Min.	Typ.	Max.	Unit	
High Level Output Voltage	V <sub>OH</sub>	I <sub>OH</sub> =-2mA (*1)	0.8V <sub>DD5</sub>	—	V <sub>DD5</sub>	V	
		I <sub>OH</sub> =-4mA (*2)					
		I <sub>OH</sub> =-8mA (*3)					
Low Level Output Voltage	V <sub>OL</sub>	I <sub>OL</sub> =2mA (*1)	0	—	0.8	V	
		I <sub>OL</sub> =4mA (*2)					
		I <sub>OL</sub> =8mA (*3)					
Input Leak Current	I <sub>I</sub>	V <sub>I</sub> =GND to V <sub>DD5</sub>	-10	—	10	μA	
		V <sub>I</sub> =GND to V <sub>DD5</sub> PULL-UP=50k (*4)	-250	—	-20		
Output Leak Current	I <sub>O</sub>	V <sub>I</sub> =GND to V <sub>DD5</sub>	-10	—	10	μA	
Power Supply Current (operating)	I <sub>DD</sub>	CLK=15MHz	3V system	—	110	150	mA
			5V system	—	20	30	mA
Power Supply Current (standby)	I <sub>DDs</sub>	3V system	—	1	3	mA	
		5V system	—	50	200	μA	
SDA Output Voltage	SDA <sub>V<sub>L</sub></sub>	—	0	—	0.4	V	
SDA Output Current	SDA <sub>I<sub>O</sub></sub>	—	3	—		mA	

\*1: TO

\*2: HSYNC\_L, VSYNC\_L, HDET, COEO

\*3: Y[7:0], C[7:0], HCL, HSY, HSY, CSYNC\_L, HVALID, VVALID, ODD, CLKX2O, CLKO

\*4: MODE[3:0], COEI, TEST0, TEST1

## AC Characteristics

(Ta=0 to 70°C, V<sub>DD3</sub>=3.3V±0.3V, V<sub>DD5</sub>=5V±0.5V)

Parameter	Symbol	Condition	Min.	Typ.	Max.	Unit
CLKX2 cycle time	t <sub>CLKX2</sub>	PAL Square Pixel	—	33.9	—	ns
		NTSC 4Fsc	—	34.9	—	ns
		NTSC Square Pixel	—	40.75	—	ns
		ITU-RS601	—	37.05	—	ns
Input Data Setup Time	t <sub>IS</sub>	—	20	—	—	ns
Input Data Hold Time	t <sub>IH</sub>	—	0	—	—	ns
Output Data Delay Time*	t <sub>OD</sub>	—	5	—	30	ns
Output Data Set Time*	t <sub>ODS</sub>	—	2	—	12	ns
Output Data Disable Time*	t <sub>ODD</sub>	—	2	—	13	ns
Cascade Priority Signal Delay Time*	t <sub>CPD</sub>	—	2	—	14	ns
Output Clock Delay Time*	t <sub>CXD</sub>	—	5	—	14	ns
Output Clock Delay Time* (CLKDIV: Low) (Internal clock)	t <sub>CD1</sub>	—	6	—	20	ns
	(CLKDIV: High) t <sub>CD2</sub>	—	8	—	22	ns
Clock Cycle Time	t <sub>C_SCL</sub>	Rpull_up=4.7kΩ	200	—	—	MHz
Clock Duty Cycle	t <sub>D_SCL</sub>	—	—	50	—	%
Low level Cycle	t <sub>L_SCL</sub>	Rpull_up=4.7kΩ	100	—	—	ns

(\*output load 15pF)



Input and Output Timing

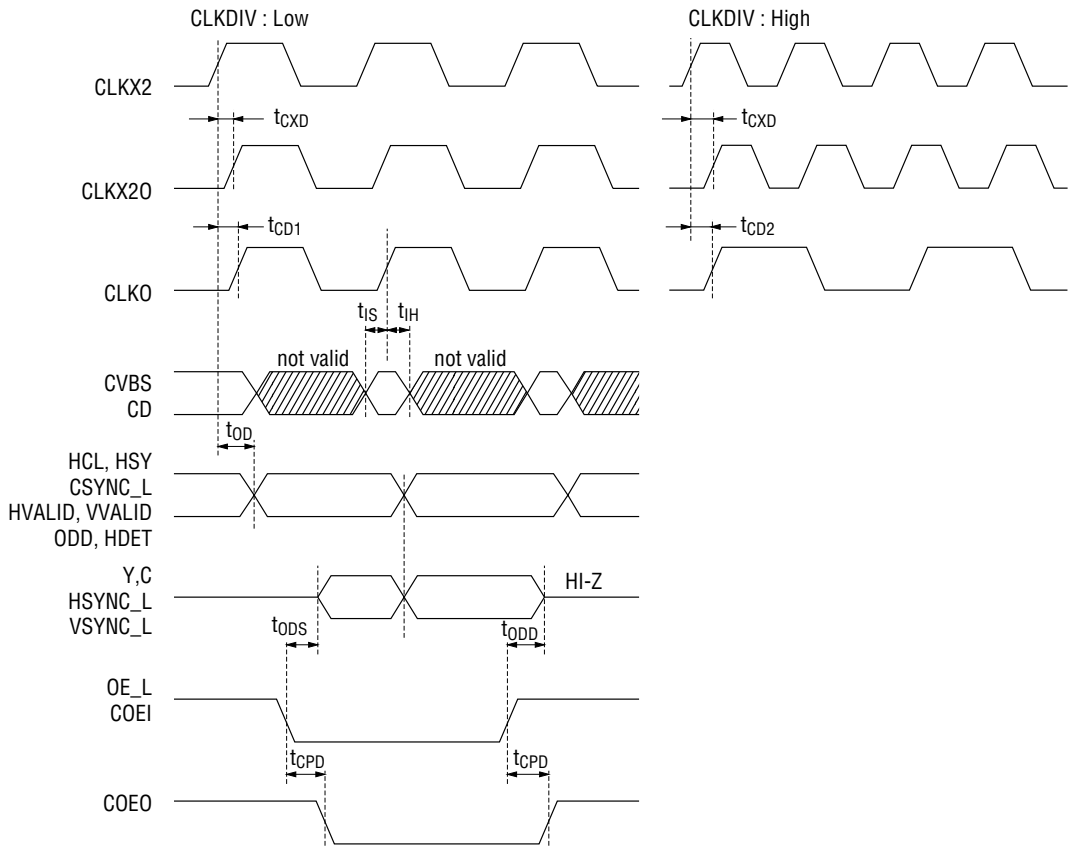

## BLOCK DESCRIPTION

### 1. Prologue Block

The prologue Block performs Y/C separation using a 2-dimensional adaptive comb filter when composite signals (CVBS) are input.

The following operation modes can be changed via the I<sup>2</sup>C-bus. The \* mark indicates a default. The default is a state that is selected when reset.

- 1) Video input mode select
  - Composite video input \*
  - S video input
- 2) Video input mode select
  - NTSC system\*
  - PAL system
- 3) Operation mode select
 

NTSC ITU recommendation BT.601	13.5MHz*
MTSC Square Pixel	12.27MHz
NTSC 4Fsc	14.32 MHz
PAL ITU recommendation BT.601	13.5MHz
PAL Square Pixel	14.75 MHz
- 4) Y/C separation mode select
  - Adaptive comb filter is used. \*
  - Unadaptive comb filter is used.
  - Comb filter is not used.

The adaptive comb filter detects the correlation up to 3 lines between continuous lines. The Y/C is separated by the comb filter according to the way of correlation if these lines are correlated. The Y/C is separated by the trap filter if these lines are not correlated not correlated (only 2 lines in the case of PAL).

In the unadaptive comb filter, the Y/C is always separated by removing the luminance component based on the average of preceding and following lines (when there is the correlation between 3 lines).

If the comb filter is not used, the Y/C is separated by the trap filter.

The Y/C separation circuit is bypassed by S video signal input.

In addition, the functions of this block work only when lines are valid as image information.

The processing of CVBS signals is not made during V-blanking.

### 2. Luminance Block

The luminance block removes synchronous signals from the signals containing luminance components after Y/C separation. The signals are corrected and output as luminance signals. This block can select the following operation modes.

- 1) Use of prefilter and sharp filter
  - Used\*
  - Not used

These filters are used for enhancing the edges of luminance component signals.

- 2) AGC loop filter time constant select
- |        |                      |
|--------|----------------------|
| slow   | Factor value 1/1024n |
| medium | 1/64n*               |
| fast   | 1/n                  |
| fixed  | 0                    |

3) Parameter for AGC reference level fine adjustment

4) Parameter for sync separation level fine adjustment

The luminance signals are synchronized by AGC correction values obtained by the above processings

- 5) Selection of aperture bandpass filter coefficient
- middle range\*
  - high range

- 6) Coring range select off\*
- ±4LBS
  - ±5LBS
  - ±7LBS

- 7) Aperture weighting factor select
- 0\*
  - 0.25
  - 0.75
  - 1.5

The profile of these signals can be corrected by coring and aperture correction.

- 8) Use of pixel position correction circuit
- Used\*
  - Not used

### 3. Chrominance Block

This is a chroma signal processing block.  
The following modes can be selected.

- 1) Use of color bandpass filter
- Used\*
  - Not used
- 2) AGC loop filter time constant select
- |        |                      |
|--------|----------------------|
| slow   | Factor value 1/1024n |
| medium | 1/64n*               |
| fast   | 1/n                  |
| fixed  | 0                    |
- 3) Parameter for burst level fine adjustment

- 4) The threshold level for valid chroma amplitude is selected base on a color burst ratio.
  - 0.5
  - 0.25\*
  - 0.125
- 5) Color killer mode select
  - Auto color killer mode\*
  - Forcible color killer

6) Parameter for color subcarrier phase fine adjustment

In this block, chroma signals pass through the chroma bandpass filter to cut an unnecessary band. To maintain a constant chroma level, UV demodulation is performed on these signals via the ACC correction circuit. (this filter can be bypassed.)

If the demodulation result does not reach a specified level, color killer signals are generated to fix the ACC gain. This functions as an auto color killer control circuit.

The UV demodulation result is output as chrominance signals via a low pass filter.

#### 4. Synchronization Block

This is a synchronizing signal processing block.

Chip output synchronizing signals and synchronizing signals for internal use are generated by this block. Various signals are output in this block and the following operation modes can be selected.

- 1-1) Fine adjustment of HSY signal (start side)
- 1-2) Fine adjustment of HSY signal (stop side)
- 2-1) Fine adjustment of HCL signal (start side)
- 2-2) Fine adjustment of HCL signal (stop side)
- 3) HSY, HCL signal enable select
  - High Level\*
  - Active

These signal are used to sink chip and clamp timing to the A/D converter
- 4) Fine adjustment of HSYNC\_L signal
- 5-1) Fine adjustment of HVALID signal (start side)
- 5-2) Fine adjustment of HVALID signal (stop side)
- 6-1) Fine adjustment of VVALID signal (start side)
- 6-2) Fine adjustment of VVALID signal (stop side)

The data signals are transmitted or received at the rising edge of the HVALID signal.

- 7) TV, VTR mode select
  - TV mode
  - VTR mode\*

The TV mode or VTR mode in synchronizing mode is selected.

The TV mode outputs a fixed pixel number per one line.

The VTR mode outputs the results of decoding in accordance with the HSYNC signal regardless

of whether a jitter exists or not. Some VTR may disturb synchronization.

## 5. Epilogue Block

The Epilogue Block outputs UV signals from the chrominance block and Y signals from the luminance block in the format based on the signal obtained by setting of the control register.

In this block, the following modes can be selected.

- 1) Display of blue back when synchronization fails.

OFF

ON\*

- 2) Output signal Y/CbCr format select

YCbCr 4 : 1 : 1

YCbCr 4 : 2 : 2\*

The chrominance signal (U, V component) outputs Cb and Cr data to the C pin in an output format described later.

- 3) Selection of 8-bit chroma signal output format

Offset binary\*

2's Complement

- 4) Output pin enable select

High impedance

Output enable\*

The Epilogue Block has a high impedance priority cascade control function to enable the bus connection of output signals. The target tristate buses are Y, C, HSYNC\_L and VSYNC\_L, and this block makes an output enable instruction for these signals

- 5) Luminance signal phase adjustment

normal\*

forward 1 clock

backward 1 clock

- 6) Chrominance signal phase adjustment

normal\*

forward 1 clock

backward 1 clock

## 6. I<sup>2</sup>C Control Block

This is the serial interface block based on the I<sup>2</sup>C standard of Phillips Corporation.

This block functions only as a Slave-Receiver.

The external control can set the internal registers (MRA, MRB, HSYT, etc.).

## 7. Test Control Block

This block is used to test this LSI. Normally it is not used.

## FUNCTIONAL DESCRIPTION

### Input Signal Level

Input signal is 8-bit in a straight binary format.  
The recommended input range is shown below.

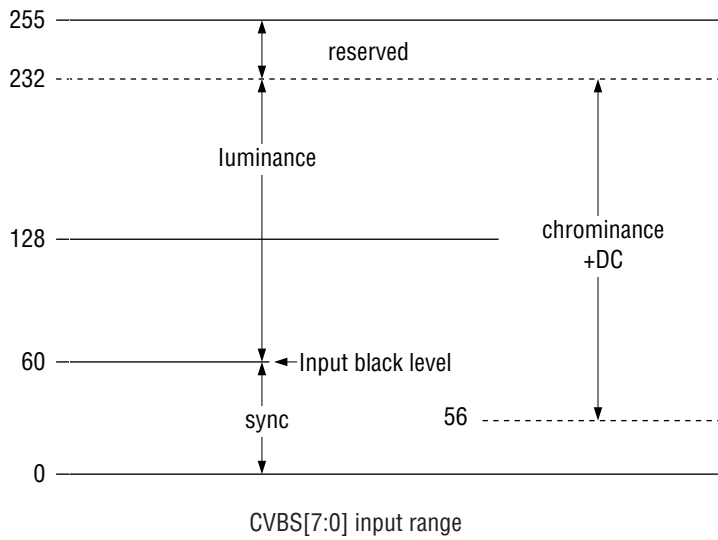

**Output format**

The YCbCr 4:2:2 format and 4:1:1 format are shown below.  
 The output format can be changed by register settings.

OUTPUT	PIXEL BYTE SEQUENCE					
Y7(MSB)	Y7	Y7	Y7	Y7	Y7	Y7
Y6	Y6	Y6	Y6	Y6	Y6	Y6
Y5	Y5	Y5	Y5	Y5	Y5	Y5
Y4	Y4	Y4	Y4	Y4	Y4	Y4
Y3	Y3	Y3	Y3	Y3	Y3	Y3
Y2	Y2	Y2	Y2	Y2	Y2	Y2
Y1	Y1	Y1	Y1	Y1	Y1	Y1
Y0(LSB)	Y0	Y0	Y0	Y0	Y0	Y0
C7(MSB)	Cb7	Cr7	Cb7	Cr7	Cb7	Cr7
C6	Cb6	Cr6	Cb6	Cr6	Cb6	Cr6
C5	Cb5	Cr5	Cb5	Cr5	Cb5	Cr5
C4	Cb4	Cr4	Cb4	Cr4	Cb4	Cr4
C3	Cb3	Cr3	Cb3	Cr3	Cb3	Cr3
C2	Cb2	Cr2	Cb2	Cr2	Cb2	Cr2
C1	Cb1	Cr1	Cb1	Cr1	Cb1	Cr1
C0(LSB)	Cb0	Cr0	Cb0	Cr0	Cb0	Cr0
Y point	0	1	2	3	4	5
C point	0		2		4	

YCbCr 4:2:2 format

OUTPUT	PIXEL BYTE SEQUENCE							
Y7(MSB)	Y7	Y7	Y7	Y7	Y7	Y7	Y7	Y7
Y6	Y6	Y6	Y6	Y6	Y6	Y6	Y6	Y6
Y5	Y5	Y5	Y5	Y5	Y5	Y5	Y5	Y5
Y4	Y4	Y4	Y4	Y4	Y4	Y4	Y4	Y4
Y3	Y3	Y3	Y3	Y3	Y3	Y3	Y3	Y3
Y2	Y2	Y2	Y2	Y2	Y2	Y2	Y2	Y2
Y1	Y1	Y1	Y1	Y1	Y1	Y1	Y1	Y1
Y0(LSB)	Y0	Y0	Y0	Y0	Y0	Y0	Y0	Y0
C7(MSB)	Cb7	Cb5	Cb3	Cb1	Cb7	Cb5	Cb3	Cb1
C6	Cb6	Cb4	Cb2	Cb0	Cb6	Cb4	Cb2	Cb0
C5	Cr7	Cr5	Cr3	Cr1	Cr7	Cr5	Cr3	Cr1
C4	Cr6	Cr4	Cr2	Cr0	Cr6	Cr4	Cr2	Cr0
C3	0	0	0	0	0	0	0	0
C2	0	0	0	0	0	0	0	0
C1	0	0	0	0	0	0	0	0
C0(LSB)	0	0	0	0	0	0	0	0
Y point	0	1	2	3	4	5	6	7
C point	0				4			

YCbCr 4:1:1 format

**Timing Description**

**AD Converter Support Signal**

The timing wave form of HSY/HCL signals, which measure the sync chip and clamp timing for the AD converter, is as follows.

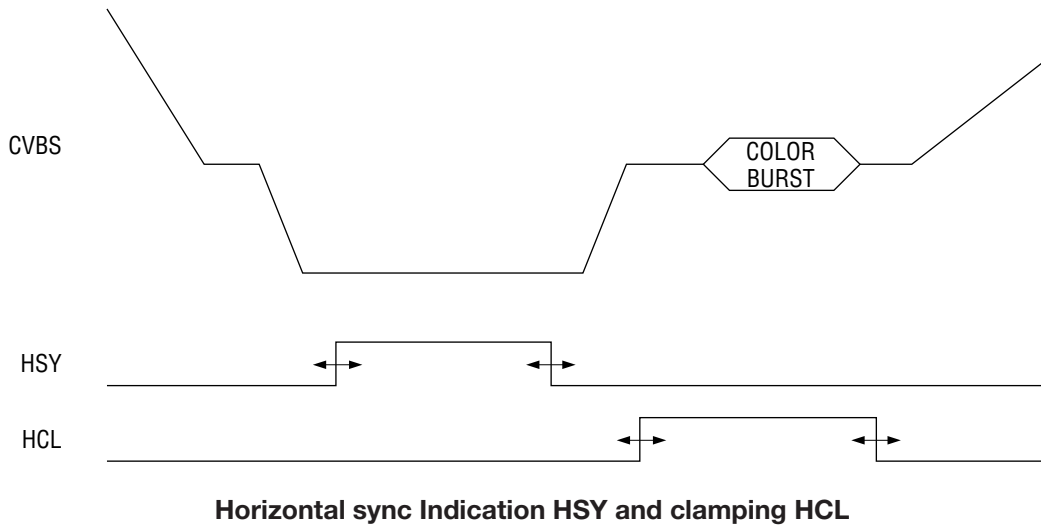

**Line control signal**

The line control signal timing is as follows.

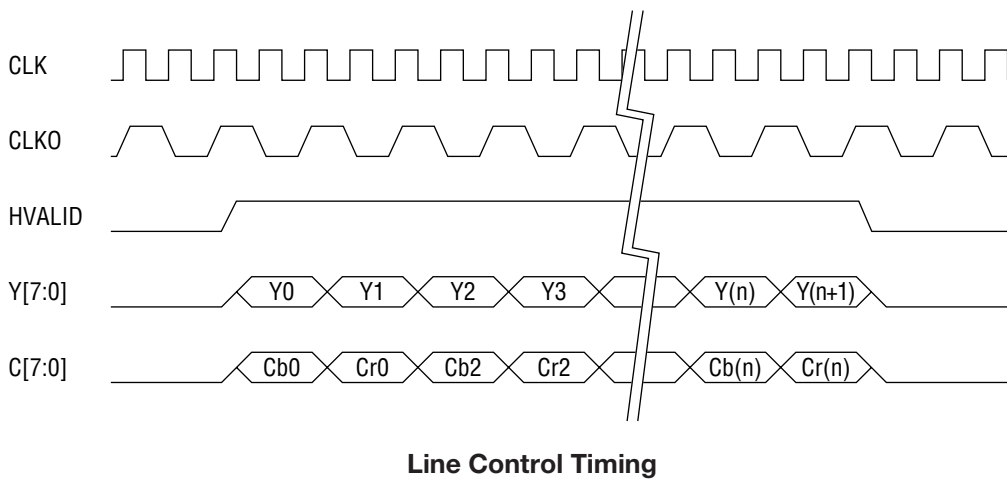



### Vertical Synchronizing 4.3 Signal

The vertical synchronizing signal timing is as follows.



**Vertical Timing (NTSC: 60Hz)**

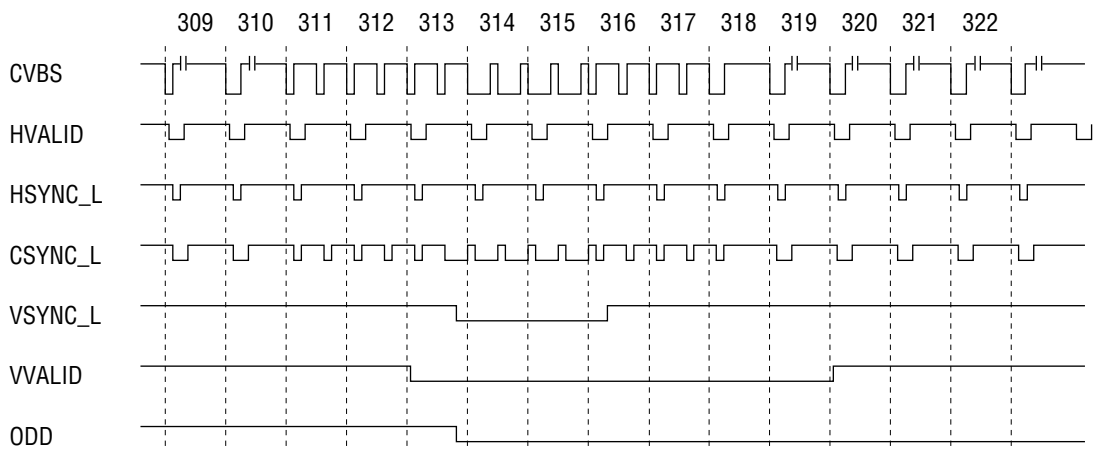
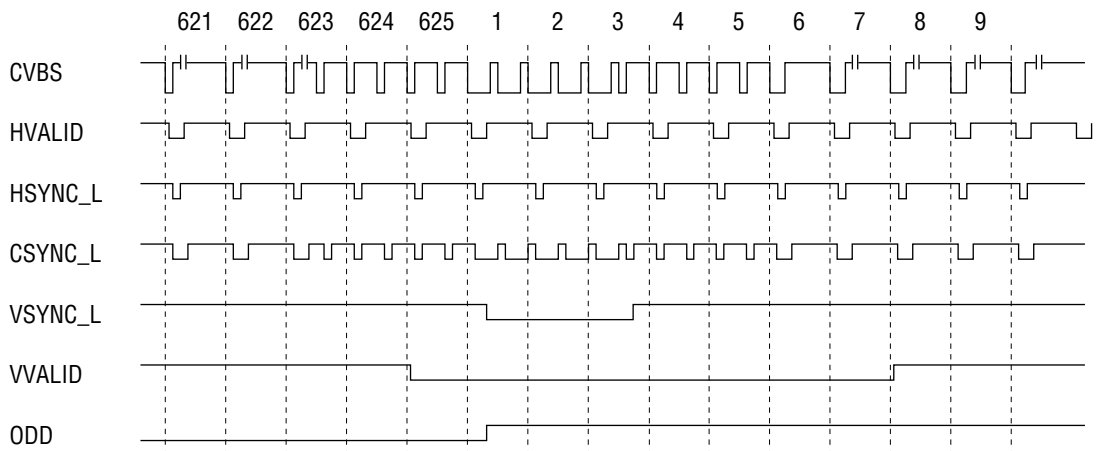

Vertical Timing (PAL: 50Hz)

### Horizontal Synchronizing Signal

The horizontal synchronizing signal timing is as follows.

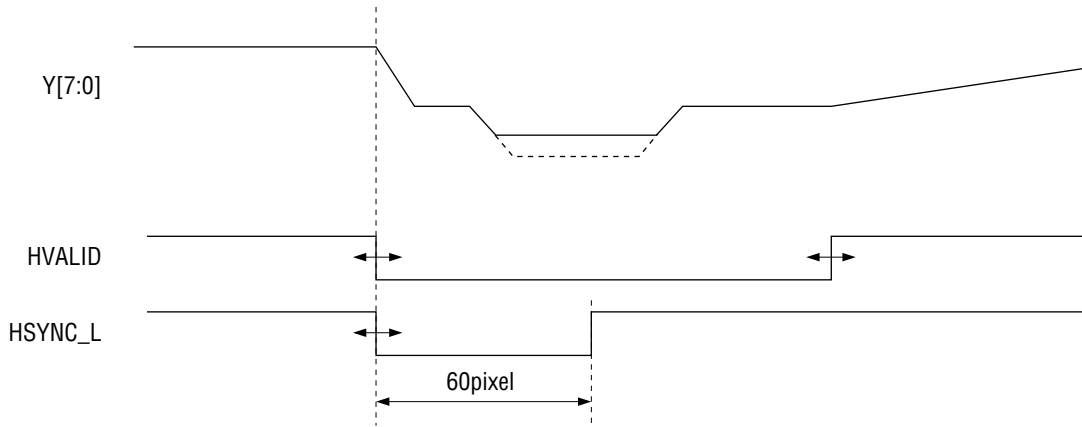

Horizontal Timing

### I<sup>2</sup>C-bus Interface Input/Output Timing

The basic input/output timing of the I<sup>2</sup>C-bus interface is as follows.

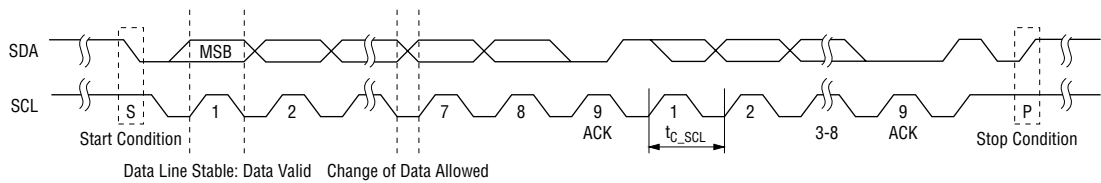

I<sup>2</sup>C-bus Basic Input/Output Timing

### I<sup>2</sup>C BUS FORMAT

The I<sup>2</sup>C-bus interface input format is shown below.

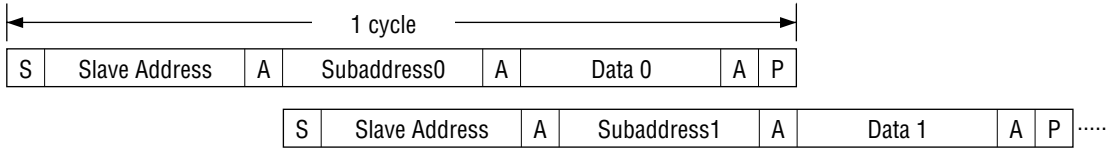

Symbol	Description
S	Start condition
Slave Address	Slave address 1000001, 8th bit is write signal.
A	Acknowledge. Generated by slave
Subaddress	Subaddress byte
Data n	Data to be written in address specified by subaddress
P	Stop condition

It is required to input the above-mentioned format from the start condition to the stop condition each time of writing a subaddress

For example, when writing the subaddresses 0 to 2, the format should be input three times.

In case data of more than one byte are transferred,



The 4th byte data and following data each are written over the same subaddress.

If one of the following matters occurs, the decoder will not return "A" (Acknowledge).

- The slave address does not match.
- A non-existent subaddress is specified.
- The write attribute of a register does not match "X" (write control bit).

The input timing is shown below.

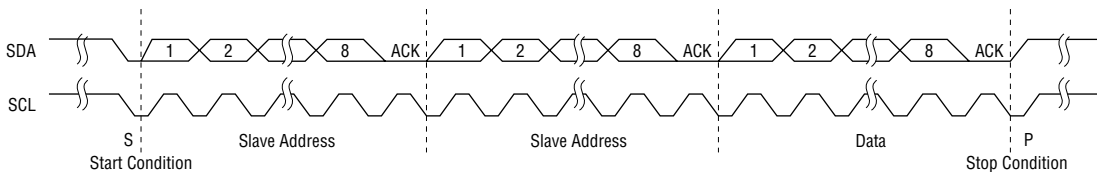

## OPERATION MODE SETTING

The video mode includes ;

1. Internal terminal mode to be directly set by a dedicated terminal
2. Register setting mode to be specified by setting the internal registers

These modes can be changed by the mode register MRA [4].

The reset state (default) is the external terminal mode.

The following registers can be set in the external terminal mode.

MRA[3]	input signal mode	*0:	Composite video input	
		1:	S-video input	
MRA[2 : 0]	input mode	*000:	NTSC ITU-R601	13.5MHz
		001:	NTSC Square Pixel	12.27MHz
		010:	MTSC 4Fsc	14.32MHz
		100:	PAL ITU-R601	13.5MHz
		101:	PAL Square Pixel	14.75MHz

## INTERNAL REGISTERS

### Register List

Register List	Subaddress	Data byte							
		D7	D6	D5	D4	D3	D2	D1	D0
Mode Register A (MRA)	0	MRA7	MRA6	MRA5	MRA4	MRA3	MRA2	MRA1	MRA0
Mode Register B (MRB)	1	MRB7	MRB6	MRB5	MRB4	MRB3	MRB2	MRB1	MRB0
Horizontal Sync Trimer (HSYT)	2	HSYT7	HSYT6	HSYT5	HSYT4	HSYT3	HSYT2	HSYT1	HSYT0
Horizontal Clamp Trimer (HCLT)	3	HCLT7	HCLT6	HCLT5	HCLT4	HCLT3	HCLT2	HCLT1	HCLT0
Horizontal Sync Delay (HSDL)	4	HSDL7	HSDL6	HSDL5	HSDL4	HSDL3	HSDL2	HSDL1	HSDL0
Horizontal Valid Trimer (HVALT)	5	HVALT7	HVALT6	HVALT5	HVALT4	HVALT3	HVALT2	HVALT1	HVALT0
Vertical Valid Trimer (VVALT)	6	VVALT7	VVALT6	VVALT5	VVALT4	VVALT3	VVALT2	VVALT1	VVALT0
Luminance Control (LUMC)	7	LUMC7	LUMC6	LUMC5	LUMC4	LUMC3	LUMC2	LUMC1	LUMC0
AGC Loop filter Control (AGCLF)	8	AGCLF7	AGCLF6	AGCLF5	AGCLF4	AGCLF3	AGCLF2	AGCLF1	AGCLF0
Sync separation level (SSEPL)	9		SSEPL6	SSEPL5	SSEPL4	SSEPL3	SSEPL2	SSEPL1	SSEPL0
Chrominance Control (CHRC)	A	CHRC7	CHRC6	CHRC5	CHRC4	CHRC3	CHRC2	CHRC1	CHRC0
ACC Loop filter Control (ACCLF)	B	ACCLF7	ACCLF6	ACCLF5	ACCLF4	ACCLF3	ACCLF2	ACCLF1	ACCLF0
Hue Control (HUE)	C	HUE7	HUE6	HUE5	HUE4	HUE3	HUE2	HUE1	HUE0
Output enable Control (OEC)	D	OEC7	OEC6	OEC5	OEC4	OEC3	OEC2	OEC1	OEC0
Output Phase Control for Data Y	E	OPCY7	OPCY6	OPCY5	OPCY4	OPCY3	OPCY2	OPCY1	OPCY0
Output Phase Control for Data C	F	OPCC7	OPCC6	OPCC5	OPCC4	OPCC3	OPCC2	OPCC1	OPCC0

### Register Description

Registers controlled by I<sup>2</sup>C bus are shown below.  
 A register setting value with an "\*" indicates the default.

Mode Register A (MRA) <default: 0x40>

MRA[7]	Undefined			
MRA[6]	Synchronization mode	0:	TV mode	
		*1:	VTR mode	
MRA[5]	Chroma format	*0:	Offset binary	
		1:	2's Complement	
MRA[4]	Override	*0:	external terminal mode	
		1:	register mode	
MRA[3]	Video Input mode	*0:	composite video input	
		1:	S video input	
MRA[2:0]	Video Input mode	*000:	NTSC CCIR601	13.5MHz
		001:	NTSC Square Pixel	12.27MHz
		010:	NTSC 4Fsc	14.32MHz
		100:	PAL CCIR601	13.5MHz
		101:	PAL Square Pixel	14.75MHz

Mode Register B (MRB) <default: 0x14>

MRB[7]	Sub Pixel Alignment	*0:	Sub Pixel Alignment is used.	
		1:	Sub Pixel Alignment is not used.	
MRB[6]	Color killer mode	*0:	Auto color killer (Chrominance signal level becomes "0" when color burst level is below specified value.)	
		*1:	Forced color killer ON (Chrominance signal level is forced to be "0".)	
MRB[5]	Pixel Sampling Ratio	*0:	(4:2:2)	1: (4:1:1)
MRB[4]	Blue Back	0:	OFF (Video signal is demodulated and output regardless detection of synchronization.)	
		*1:	AUTO (Blue Back is output when synchronization is not detected.)	

MRB[3]	Sync enable, clamping pulse	*0: HCL, HSY outputs "HIGH" level 1: HCL, HSY outputs active
MRB[2]	Black level control	0: Black level 7.5IRE *1: Black level 0IRE (Valid only for NTSC input.)
MRB[1:0]	Y/C separation mode	*00: adaptive comb filter (Operation mode is selected monitoring the correlation of 3 lines.) 01: nonadaptive comb filter (Operation mode is always fixed.) 10: Comb filter is not used. 11: undefined

## Horizontal Sync Trimer (HSYT) &lt;default: 0x00&gt;

HSYT[7:4]	HSY begin trimer (8/pixel)	0xC: -4 (-32)	~0xB: +11 (+88)
HSYT[3:0]	HSY stop trimer (8/pixel)	0xC: -4 (-32)	~0xB: +11 (+88)

## Horizontal Clamp Trimer (HCLT) &lt;default: 0x00&gt;

HCLT[7:4]	HCL begin trimer (8/pixel)	0x8: -8 (-64)	~0x7: +7 (+56)
HCLT[3:0]	HCL stop trimer (8/pixel)	0x8: -8 (-64)	~0x7: +7 (+56)

## Horizontal Sync Delay (HSDL) &lt;default: 0x00&gt;

HSDL[7:4]	HSYNC_L delay trimer (4/pixel)	0x80: -128 (-512)	~0x7F: +127 (508)
-----------	--------------------------------	-------------------	-------------------

## Horizontal Valid Trimer (HVALT) &lt;default: 0x00&gt;

HVALT[7:4]	HVALID begin trimer (1/pixel)	0x4: -8 (-64)	~0x3: +7 (56)
HVALT[3:0]	HVALID stop trimer (1/pixel)	0x4: -8 (-64)	~0x3: +7 (56)

## Vertical Valid Trimer (VVALT) &lt;default: 0x00&gt;

VVALT[7:4]	VVALID begin trimer (/line)	0x8: -8	~0x7: +7
VVALT[3:0]	VVALID stop trimer (/line)	0x8: -8	~0x7: +7

Luminance Control (LUMC) <default: 0x40>

LUMC[7]	Undefined			
LUMC[6]	Use of Pre-filter	0:	0:	Prefilter is not used.
		*1:	*1:	Prefilter is used.
LUMC[5:4]	Aperture bandpass select	*00:	*00:	middle range
		01:	01:	
		10:	10:	
		11:	11:	high range
LUMC[3:2]	Coring range select	*00:	*00:	coring off
		01:	01:	+/-3LSB
		10:	10:	+/-4LSB
		11:	11:	+/-6LSB
LUMC[1:0]	Aperture filter weighting factor	*00:	*00:	0
		01:	01:	0.25
		10:	10:	0.5
		11:	11:	1

AGC Loop filter control (AGCLF) <default: 0x40>

AGCLF[7:6]	AGC loop filter time constant	00:	00:	slow
		*01:	*01:	medium
		10:	10:	fast
		11:	11:	fixed
AGCLF[5:0]	AGC reference level	0x20:	0x20:	-32
		~0xIF:	~0xIF:	+31

Sync separation level (SSEPL) <default: 0x00>

SSEPL[6:0]	Sync separation level	0x40:	0x40:	-64
		~0x3F:	~0x3F:	+63



## Chrominance Control (CHRC) &lt;default: 0x1&gt;

CHRC[7:3]	Undefined				
CHRC[2]	Chroma bandpass filter	0:	OFF	*1:	ON
CHRC[1:0]	Color kill threshold factor	00:	0.5*color burst level		
		*01:	0.25*color burst level		
		10:	0.125*color burst level		
		11:	Undefined		

## ACC Loop filter control (ACCLF) &lt;default: 0x20&gt;

ACCLF[7]	Undefined				
ACCLF[6:5]	ACC loop filter time constant	00:	slow		
		*01:	medium		
		10:	fast		
		11:	fixed		
ACCLF[4:0]	ACC reference level	0x10:	-16	~0x0F:	+15

## Hue control (HUE) &lt;default: 0x00&gt;

HUE[7:0]	Hue control	0x80:	-180 degrees	~0x7F:	178.6 degrees
----------	-------------	-------	--------------	--------	---------------

## Output enable control (OEC) &lt;default: 0xF&gt;

OEC[7:4]	Undefined				
OEC[3]	Output enable for data C	0:	Hi-impedance		
		*1:	active		
OEC[2]	Output enable for HSYNC_L	0:	Hi-impedance		
		*1:	active		
OEC[1]	Output enable for VSYNC_L	0:	Hi-impedance		
		*1:	active		
OEC[0]	Output enable for data Y	0:	Hi-impedance		
		*1:	active		

Output phase control for data Y (OPCY) <default: 0x00>

OPCY[7:2] Undefined

OPCY[1:0] Output phase control for data Y \*0: normal  
1: forward 1 clock  
2: Undefined  
3: backward 1 clock

Output phase control for data C (OPCC) <default: 0x00>

OPCCY[7:2] Undefined

OPCC[1:0] Output phase control for data C \*0: normal  
1: forward 1 clock  
2: Undefined  
3: backward 1 clock

**Relationship between Register Setting Value and Adjusted Value**

Horizontal Sync Timer

Position adjustment of sync chip clamp timing signal

HSYT [7:4] :Adjusting the starting position

Register Setting Value (0x)	C	D	E	F	0	1	2	3	4	5	6	7	8	9	A	B
Adjusted Value (Pixel)	-32	-24	-16	-8	0	+8	+16	+24	+32	+40	+48	+56	+64	+72	+80	+88

HSYT [3:0] :Adjusting the end position

Register Setting Value (0x)	C	D	E	F	0	1	2	3	4	5	6	7	8	9	A	B
Adjusted Value (Pixel)	-32	-24	-16	-8	0	+8	+16	+24	+32	+40	+48	+56	+64	+72	+80	+88

Horizontal Clamp Timer

Position adjustment of pedestal clamp timing signal

HCLT [7:4] :Adjusting the starting position

Register Setting Value (0x)	8	9	A	B	C	D	E	F	0	1	2	3	4	5	6	7
Adjusted Value (Pixel)	-64	-56	-48	-40	-32	-24	-16	-8	0	+8	+16	+24	+32	+40	+48	+56

HCLT [3:0] :Adjusting the end position

Register Setting Value (0x)	8	9	A	B	C	D	E	F	0	1	2	3	4	5	6	7
Adjusted Value (Pixel)	-64	-56	-48	-40	-32	-24	-16	-8	0	+8	+16	+24	+32	+40	+48	+56

Horizontal Sync Delay

Adjustment of the starting position of horizontal sync signal

HSDL [7:0]

		MSB[7 : 4]															
		8	9	A	B	C	D	E	F	0	1	2	3	4	5	6	7
LSB [3 : 0]	0	-512	-448	-384	-320	-256	-192	-128	-64	0	+64	+128	+192	+256	+320	+384	+448
	1	-508	-444	-380	-316	-252	-188	-124	-60	+4	+68	+132	+196	+260	+324	+388	+452
	2	-504	-440	-376	-312	-248	-184	-120	-56	+8	+72	+136	+200	+264	+328	+392	+456
	3	-500	-436	-372	-308	-244	-180	-116	-52	+12	+76	+140	+204	+268	+332	+396	+460
	4	-496	-432	-368	-304	-240	-176	-112	-48	+16	+80	+144	+208	+272	+336	+400	+464
	5	-492	-428	-364	-300	-236	-172	-108	-44	+20	+84	+148	+212	+276	+340	+404	+468
	6	-488	-424	-360	-296	-232	-168	-104	-40	+24	+88	+152	+216	+280	+344	+408	+472
	7	-484	-420	-356	-292	-228	-164	-100	-36	+28	+92	+156	+220	+284	+348	+412	+476
	8	-480	-416	-352	-288	-224	-160	-96	-32	+32	+96	+160	+224	+288	+352	+416	+480
	9	-476	-412	-348	-284	-220	-156	-92	-28	+36	+100	+164	+228	+292	+356	+420	+484
	A	-472	-408	-344	-280	-216	-152	-88	-24	+40	+104	+168	+232	+296	+360	+424	+488
	B	-468	-404	-340	-276	-212	-148	-84	-20	+44	+108	+172	+236	+300	+364	+428	+492
	C	-464	-400	-336	-272	-208	-144	-80	-16	+48	+112	+176	+240	+304	+368	+432	+496
	D	-460	-396	-332	-268	-204	-140	-76	-12	+52	+116	+180	+244	+308	+372	+436	+500
	E	-456	-392	-328	-264	-200	-136	-72	-8	+56	+120	+184	+248	+312	+376	+440	+504
	F	-452	-388	-324	-260	-196	-132	-68	-4	+60	+124	+188	+252	+316	+380	+444	+508

Horizontal Valid Timer

Position adjustment of horizontal valid pixel timing signal

HVALT [7:4] :Adjusting the starting position

Register Setting Value (0x)	8	9	A	B	C	D	E	F	0	1	2	3	4	5	6	7
Adjusted Value (Pixel)	-8	-7	-6	-5	-4	-3	-2	-1	0	+1	+2	+3	+4	+5	+6	+7

HVALT [3:0] :Adjusting the end position

Register Setting Value (0x)	8	9	A	B	C	D	E	F	0	1	2	3	4	5	6	7
Adjusted Value (Pixel)	-8	-7	-6	-5	-4	-3	-2	-1	0	+1	+2	+3	+4	+5	+6	+7

Vertical Valid Timer

Position adjustment of vertical valid line timing signal

VVALT [7:4] :Adjusting the starting position

Register Setting Value (0x)	8	9	A	B	C	D	E	F	0	1	2	3	4	5	6	7
Adjusted Value (Line)	-8	-7	-6	-5	-4	-3	-2	-1	0	+1	+2	+3	+4	+5	+6	+7

VVALT [3:0] :Adjusting the end position

Register Setting Value (0x)	8	9	A	B	C	D	E	F	0	1	2	3	4	5	6	7
Adjusted Value (Line)	-8	-7	-6	-5	-4	-3	-2	-1	0	+1	+2	+3	+4	+5	+6	+7

AGC Loop filter control

AGCLF [5:0] :Adjusting sync level

Register Setting Value (0x)	MSB [5 : 4]				
	2	3	0	1	
LSB [3 : 0]	0	-32	-16	0	+16
	1	-31	-15	+1	+17
	2	-30	-14	+2	+18
	3	-29	-13	+3	+19
	4	-28	-12	+4	+20
	5	-27	-11	+5	+21
	6	-26	-10	+6	+22
	7	-25	-9	+7	+23
	8	-24	-8	+8	+24
	9	-23	-7	+9	+25
	A	-22	-6	+10	+26
	B	-21	-5	+11	+27
	C	-20	-4	+12	+28
	D	-19	-3	+13	+29
	E	-18	-2	+14	+30
	F	-17	-1	+15	+31

Sync separation level

SSEPL [6:0] :Adjusting the blanking level

Register Setting Value (0x)	MSB [6 : 4]								
	4	5	6	7	0	1	2	3	
LSB [3 : 0]	0	-64	-48	-32	-16	0	+16	+32	+48
	1	-63	-47	-31	-15	+1	+17	+33	+49
	2	-62	-46	-30	-14	+2	+18	+34	+50
	3	-61	-45	-29	-13	+3	+19	+35	+51
	4	-60	-44	-28	-12	+4	+20	+36	+52
	5	-59	-43	-27	-11	+5	+21	+37	+53
	6	-58	-42	-26	-10	+6	+22	+38	+54
	7	-57	-41	-25	-9	+7	+23	+39	+55
	8	-56	-40	-24	-8	+8	+24	+40	+56
	9	-55	-39	-23	-7	+9	+25	+41	+57
	A	-54	-38	-22	-6	+10	+26	+42	+58
	B	-53	-37	-21	-5	+11	+27	+43	+59
	C	-52	-36	-20	-4	+12	+28	+44	+60
	D	-51	-35	-19	-3	+13	+29	+45	+61
	E	-50	-34	-18	-2	+14	+30	+46	+62
	F	-49	-33	-17	-1	+15	+31	+47	+63

ACC Loop filter control

ACCLF [4:0] :Adjusting the color burst level

Register Setting Value (0x)	MSB [4]		
	1	0	
LSB [3 : 0]	0	-16	0
	1	-15	+1
	2	-14	+2
	3	-13	+3
	4	-12	+4
	5	-11	+5
	6	-10	+6
	7	-9	+7
	8	-8	+8
	9	-7	+9
	A	-6	+10
	B	-5	+11
	C	-4	+12
	D	-3	+13
	E	-2	+14
	F	-1	+15

Hue control  
Adjustment of color subcarrier phase

HUE [7:0]

Register Setting Value (0x)	MSB [7 : 4]																
	8	9	A	B	C	D	E	F	0	1	2	3	4	5	6	7	
LSB [3 : 0]	0	-180.0	-157.5	-135.0	-112.5	-90.0	-67.5	-45.0	-22.5	+0.0	+22.5	+45.0	+67.5	+90.0	+112.5	+135.0	+157.5
	1	-178.6	-156.1	-133.6	-111.1	-88.6	-66.1	-43.6	-21.1	+1.4	+23.9	+46.4	+68.9	+91.4	+113.9	+136.4	+158.9
	2	-177.2	-154.7	-132.2	-109.7	-87.2	-64.7	-42.2	-19.7	+2.8	+25.3	+47.8	+70.3	+92.8	+115.3	+137.8	+160.3
	3	-175.8	-153.3	-130.8	-108.3	-85.8	-63.3	-40.8	-18.3	+4.2	+26.7	+49.2	+71.7	+94.2	+116.7	+139.2	+161.7
	4	-174.4	-151.9	-129.4	-106.9	-84.4	-61.9	-39.4	-16.9	+5.6	+28.1	+50.6	+73.1	+95.6	+118.1	+140.6	+163.1
	5	-173.0	-150.5	-128.0	-105.5	-83.0	-60.5	-38.0	-15.5	+7.0	+29.5	+52.0	+74.5	+97.0	+119.5	+142.0	+164.5
	6	-171.6	-149.1	-126.6	-104.1	-81.6	-59.1	-36.6	-14.1	+8.4	+30.9	+53.4	+75.9	+98.4	+120.9	+143.4	+165.9
	7	-170.2	-147.7	-125.2	-102.7	-80.2	-57.7	-35.2	-12.7	+9.8	+32.3	+54.8	+77.3	+99.8	+122.3	+144.8	+167.3
	8	-168.8	-146.3	-123.8	-101.3	-78.8	-56.3	-33.8	-11.3	+11.3	+33.8	+56.3	+78.8	+101.3	+123.8	+146.3	+168.8
	9	-167.3	-144.8	-122.3	-99.8	-77.3	-54.8	-32.3	-9.8	+12.7	+35.2	+57.7	+80.2	+102.7	+125.2	+147.7	+170.2
	A	-165.9	-143.4	-120.9	-98.4	-75.9	-53.4	-30.9	-8.4	+14.1	+36.6	+59.1	+81.6	+104.1	+126.6	+149.1	+171.6
	B	-164.5	-142.0	-119.5	-97.0	-74.5	-52.0	-29.5	-7.0	+15.5	+38.0	+60.5	+83.0	+105.5	+128.0	+150.5	+173.0
	C	-163.1	-140.6	-118.1	-95.6	-73.1	-50.6	-28.1	-5.6	+16.9	+39.4	+61.9	+84.4	+106.9	+129.4	+151.9	+174.4
	D	-161.7	-139.2	-116.7	-94.2	-71.7	-49.2	-26.7	-4.2	+18.3	+40.8	+63.3	+85.8	+108.3	+130.8	+153.3	+175.8
	E	-160.3	-137.8	-115.3	-92.8	-70.3	-47.8	-25.3	-2.8	+19.7	+42.2	+64.7	+87.2	+109.7	+132.2	+154.7	+177.2
	F	-158.9	-136.4	-113.9	-91.4	-68.9	-46.4	-23.9	-1.4	+21.1	+43.6	+66.1	+88.6	+111.1	+133.6	+156.1	+178.6

### APPLICATION CIRCUIT EXAMPLE

Example of supplying the pixel clock from an external source

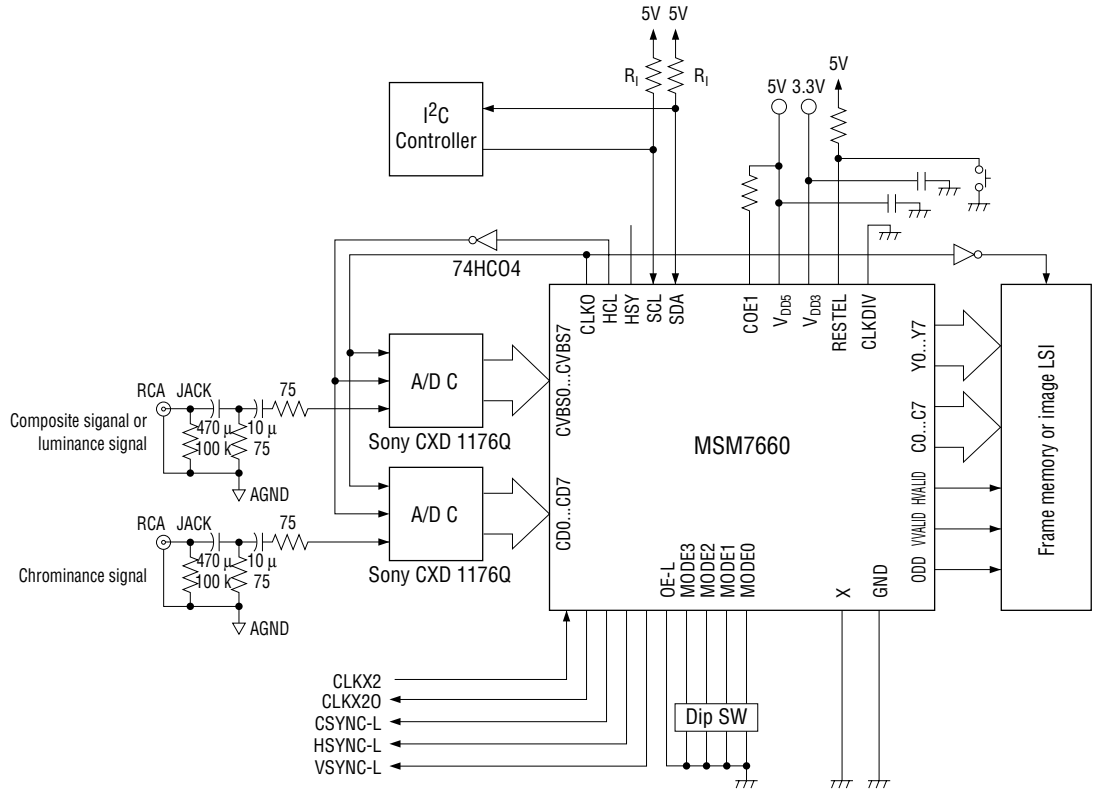



### CASCADE PRIORITY CONTROL

The MSM7660 can set Y/C signal output to high impedance, and can be wired with another bus that can be set to high impedance output.

Y/C output enable/disable is selected by the OE\_L pin and register OEC. Cascade connection of COEI and COEO makes priority control possible. Priority is assigned to devices and when a device with higher priority is in enable status, devices with lower priority are automatically disabled. The priority control table is shown below.

Register setting				Input		Output				
OEC[0]	OEC[1]	OEC[2]	OEC[3]	coei	ce_l	Y0..Y7	VSYNC_I	HSYNC_I	C0..C7	COEO
X	X	X	X	0	X	Z	Z	Z	Z	0
0	0	0	0	1	1	Z	Z	Z	Z	1
1	0	0	1	1	1	enable	Z	Z	enable	0
1	0	0	0	1	1	enable	Z	Z	Z	0
0	0	0	1	1	1	Z	Z	Z	enable	0
0	1	1	0	1	1	Z	enable	enable	Z	1
X	X	X	X	1	0	enable	enable	enable	enable	0

Z : High impedance

**Cascade Priority Control Table**

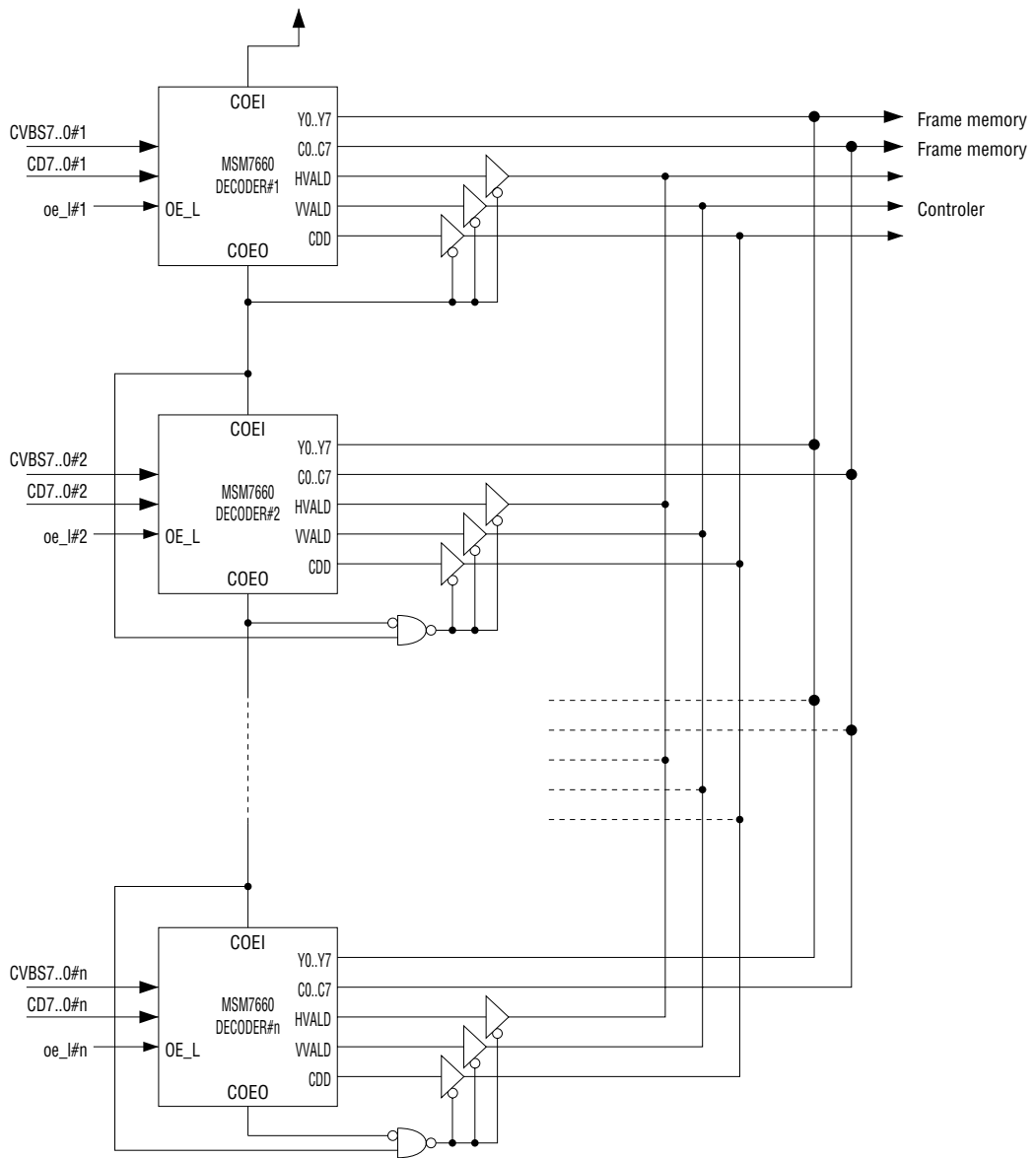

**Cascade Priority Control Connection Example**

PACKAGE OUTLINES AND DIMENSIONS

