

CFD4448

**SURFACE MOUNT
ULTRA HIGH SPEED
SILICON SWITCHING DIODE**



www.centrasemi.com

TLP™
Tiny
Leadless
Package

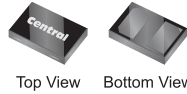

SOD-882L CASE

DESCRIPTION:

The CENTRAL SEMICONDUCTOR CFD4448 is an ultra high speed switching diode ideal for applications where very small size and operational efficiency are prime requirements.

MARKING CODE: X

APPLICATIONS:

- General Purpose Switching
- DC / DC Converters
- Flyback Diodes
- Polarity Protection
- Battery powered applications including Cell Phones, Digital Cameras, Pagers, PDAs, Laptop Computers, etc.

FEATURES:

- Current ($I_O=250\text{mA}$)
- Forward Voltage Drop ($V_F=0.91\text{V TYP @ }100\text{mA}$)
- Extremely Fast Switching Speed (4ns Max)
- Small TLP, 1.0 x 0.6 x 0.4mm, Ultra Low Profile Leadless Surface Mount Package.

MAXIMUM RATINGS: ($T_A=25^\circ\text{C}$)

Peak Repetitive Reverse Voltage
Continuous Forward Current
Peak Repetitive Forward Current
Peak Forward Surge Current, $t_p=1.0\mu\text{s}$
Peak Forward Surge Current, $t_p=1.0\text{s}$
Power Dissipation
Operating and Storage Junction Temperature
Thermal Resistance

SYMBOL

SYMBOL		UNITS
V_{RRM}	120	V
I_F	250	mA
I_{FRM}	500	mA
I_{FSM}	4.0	A
I_{FSM}	1.0	A
P_D	100	mW
T_J, T_{stg}	-65 to +150	$^\circ\text{C}$
Θ_{JA}	1250	$^\circ\text{C/W}$

ELECTRICAL CHARACTERISTICS: ($T_A=25^\circ\text{C}$ unless otherwise noted)

SYMBOL	TEST CONDITIONS	MIN	TYP	MAX	UNITS
I_R	$V_R=50\text{V}$			300	nA
I_R	$V_R=50\text{V}, T_A=125^\circ\text{C}$			100	μA
I_R	$V_R=100\text{V}$			500	nA
BV_R	$I_R=100\mu\text{A}$	120	150		V
V_F	$I_F=1.0\text{mA}$	0.55	0.59	0.65	V
V_F	$I_F=10\text{mA}$	0.67	0.72	0.77	V
V_F	$I_F=100\text{mA}$	0.85	0.91	1.0	V
C_T	$V_R=0, f=1.0\text{MHz}$			2.0	pF
t_{rr}	$I_R=I_F=10\text{mA}, I_{rr}=1.0\text{mA}, R_L=100\Omega$		2.0	4.0	ns

R0 (16-September 2010)

CFD4448

**SURFACE MOUNT
ULTRA HIGH SPEED
SILICON SWITCHING DIODE**



SOD-882L CASE - MECHANICAL OUTLINE

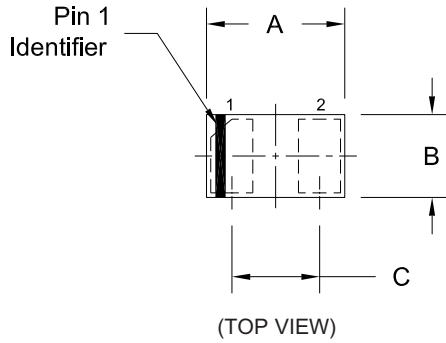

SYMBOL	INCHES		MILLIMETERS	
	MIN	MAX	MIN	MAX
A	0.037	0.041	0.95	1.05
B	0.022	0.026	0.55	0.65
C	0.026		0.65	
D	0.000	0.002	0.00	0.05
E	0.012	0.016	0.30	0.40
F	0.018	0.022	0.45	0.55
G	0.008	0.012	0.20	0.30

SOD-882L (REV:R0)

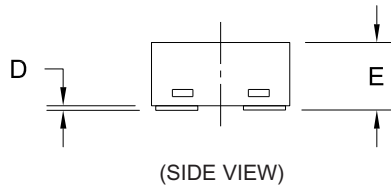

LEAD CODE:

- 1) Cathode
- 2) Anode

MARKING CODE: X

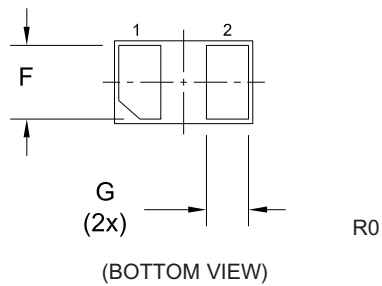

R0 (16-September 2010)