

**PLEASE CHECK WWW.MOLEX.COM FOR LATEST PART INFORMATION**

**Part Number:** **0039000207**  
**Status:** **Active**  
**Overview:** [minifit\\_jr](#)  
**Description:** 4.20mm (.165") Pitch Mini-Fit™ Crimp Terminal, Female, with Tin (Sn) over Nickel (Ni), 18-24 AWG, Reel

**Documents:**

<a href="#">Test Summary (PDF)</a>	<a href="#">Product Specification PS-5556-002 (PDF)</a>
<a href="#">Drawing (PDF)</a>	<a href="#">Product Specification PS-5556-003 (PDF)</a>
<a href="#">Product Specification PS-5556-001 (PDF)</a>	<a href="#">RoHS Certificate of Compliance (PDF)</a>

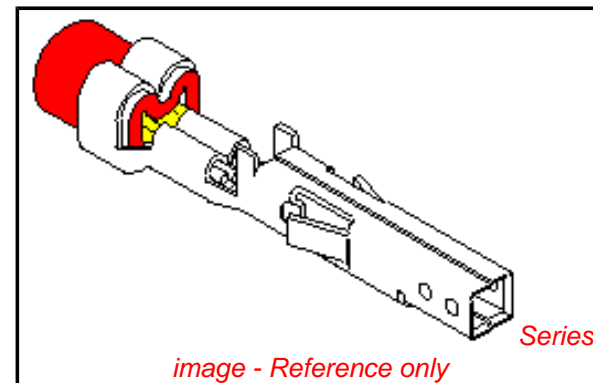

**General**

Product Family	Crimp Terminals
Series	5556
Crimp Quality Equipment	Yes
Overview	<a href="#">minifit_jr</a>
Product Name	Mini-Fit®

**Physical**

Durability (mating cycles max)	30
Gender	Female
Material - Metal	Brass
Material - Plating Mating	Tin
Material - Plating Termination	Nickel
Packaging Type	Reel
Plating min: Mating (µin)	100
Plating min: Mating (µm)	2.54
Plating min: Termination (µin)	50
Plating min: Termination (µm)	1.27
Termination Interface: Style	Crimp or Compression
Wire Insulation Diameter	1.30-3.10mm (.051-.122")
Wire Size AWG	18, 20, 22, 24
Wire Size mm²	N/A

**Electrical**

Current - Maximum per Contact	9A
Voltage - Maximum	600V

**Material Info**

Old Part Number	5556-SP
-----------------	---------

**Reference - Drawing Numbers**

Packaging Specification	PK-5556-001
Product Specification	PS-5556-001, PS-5556-002, PS-5556-003
Test Summary	TS-5556-002

<p><b>EU RoHS</b>  <b>ELV and RoHS</b>  <b>Compliant</b>  <b>REACH SVHC</b>  <b>Contains SVHC: No</b>  <b>Halogen-Free</b>  <b>Status</b>  <b>Halogen-Free</b></p>	<p><b>China RoHS</b></p>
--	--------------------------

**Need more information on product environmental compliance?**

Email [productcompliance@molex.com](mailto:productcompliance@molex.com)  
For a multiple part number RoHS Certificate of Compliance, [click here](#)

Please visit the [Contact Us](#) section for any non-product compliance questions.

**Search Parts in this Series**  
5556Series

**Mates With**  
5558 Male Crimp Terminals, Mini-Fit Jr.™ Header, Dual Row, 5566 , 5569

**Use With**  
5557 Mini-Fit Jr.™ Receptacle Housing, 30067 TPA, 42474 BMI Panel Mount, 5559 Mini-Fit Jr.™ Plug Housing, Dual Row

**Application Tooling | FAQ**  
*Tooling specifications and manuals are found by selecting the products below. Crimp Height Specifications are then contained in the Application Tooling Specification document.*

<b>Global</b>	
<b>Description</b>	<b>Product #</b>
FineAdjust™	0639015600
Applicator for Mini-Fit Jr.™, Mini-Fit HCS™ Crimp Terminals,	

18-24 AWG and smaller insulation T2 Terminator Die	<u>0639102600</u>
FineAdjust™ Applicator	<u>0639002600</u>
FineAdjust™ Applicator, Small Insulation	<u>0639002900</u>
T2 Terminator Tooling Die	<u>0639102900</u>
Extraction Tool	<u>0011030044</u>
Hand Crimp Tool for Mini-Fit™ Jr. Male and Female Crimp Terminals, 16-24 AWG	<u>0638190900</u>

This document was generated on 06/01/2010

**PLEASE CHECK [WWW.MOLEX.COM](http://WWW.MOLEX.COM) FOR LATEST PART INFORMATION**

PART NO.	ENG. NO.	MAT'L.	PLATE	WIRE GAGE	QUANTITY PER REEL	DIM. "B"	DIM. "C"	DIM. "D"	DIM. "E"	DIM. "F"	DIM. "G"	
39-00-0207	5556-SP	A	A	18-24 GA.	4,000	.142±.012 (3.60±0.30)	.177±.016 (4.50±0.40)	.035 (0.90)	.075±.012 (1.90±0.30)	.091±.016 (2.40±0.40)	.020 (0.50)	
39-00-0208	5556-SPL			22-28 GA.	6,000	.091±.012 (2.30±0.30)	.091±.016 (2.30±0.40)	.024 (0.60)	.071±.012 (1.80±0.30)	.065±.016 (1.65±0.40)	.016 (0.40)	
39-00-0209	5556-S2P			16 GA.	4,000	.142±.012 (3.60±0.30)	.177±.016 (4.50±0.30)	.035 (0.90)	.091±.012 (2.30±0.30)	.106±.016 (2.70±0.40)	.024 (0.60)	
39-00-0210	5556-S2PL											
39-00-0211	5556-S3P											
39-00-0212	5556-S3PL											
NOT TOOLED	5556-S5P	B	A	28-30 GA.	6,000	.091±.012 (2.30±0.30)	.091±.016 (2.30±0.40)	.024 (.60)	.050±.010 (1.27±0.25)	.044±.010 (1.12±0.25)	.010 (0.25)	
NOT TOOLED	5556-S5PL			18-24 GA.	4,000	.142±.012 (3.60±0.30)	.177±.016 (4.50±0.40)	.035 (0.90)	.075±.012 (1.90±0.30)	.091±.016 (2.40±0.40)	.020 (0.50)	
39-00-0213	5556-PBSP			22-28 GA.	6,000	.091±.012 (2.30±0.30)	.091±.016 (2.30±0.40)	.024 (0.60)	.071±.012 (1.80±0.30)	.065±.016 (1.65±0.40)	.016 (0.40)	
39-00-0214	5556-PBSPL			16 GA.	4,000	.142±.012 (3.60±0.30)	.177±.016 (4.50±0.30)	.035 (0.90)	.091±.012 (2.30±0.30)	.106±.016 (2.70±0.40)	.024 (0.60)	
39-00-0215	5556-PBS2P											
39-00-0216	5556-PBS2PL											
39-00-0217	5556-PBS3P											
39-00-0218	5556-PBS3PL											
NOT TOOLED	5556-PBS5P			28-30 GA.	6,000	.091±.012 (2.30±0.30)	.091±.016 (2.30±0.40)	.024 (.60)	.050±.010 (1.27±0.25)	.044±.010 (1.12±0.25)	.010 (0.25)	
NOT TOOLED	5556-PBS5PL											

**LEGEND:**

5556 - \*\* S \* P \*

BASE NO. \_\_\_\_\_

MATERIAL \_\_\_\_\_

BLANK= BRASS

PB= PHOS. BRONZE

S= TIN OVER NICKEL

PLATING & CRIMP SIZE COMB. \_\_\_\_\_

BLANK THRU 5

CHAIN OR LOOSE \_\_\_\_\_

BLANK= CHAIN

L= LOOSE

**NOTES:**

- PART DESIGNED IN METRIC.
- TERMINAL FOR USE WITH 5557, 42474, 43760 AND 30067 SERIES HOUSINGS.
- MATES WITH 5558, 5566 AND 5569 SERIES CONNECTORS.
- REFER TO DWG. NO. CS-5556\*/5558\* FOR CRIMP SPECIFICATIONS.
- MATERIAL:
  - A= BRASS, CDA 260
  - B= PHOS. BRONZE, CDA 510
- PLATING:
  - A= .000100/(.00254) MIN. BRIGHT TIN OVER .000050/(.00127) MIN. NICKEL.
- PRODUCT SPECIFICATION: PS-5556-001, PS-5556-002, PS-5556-003

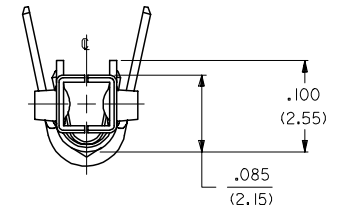
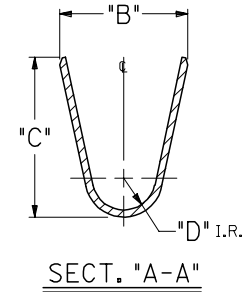
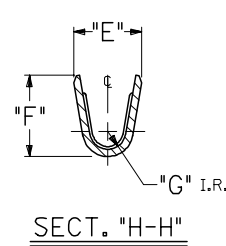
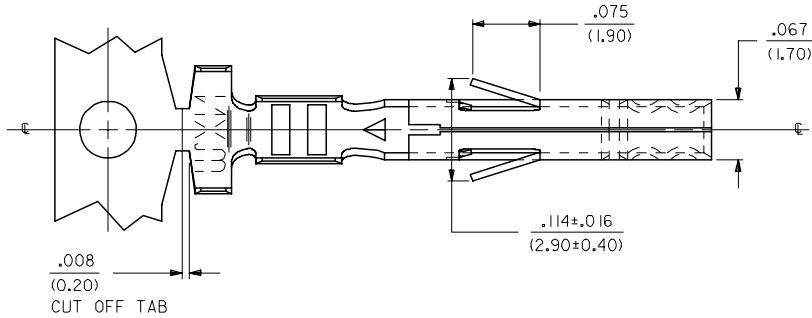

**RoHS COMPLIANT**

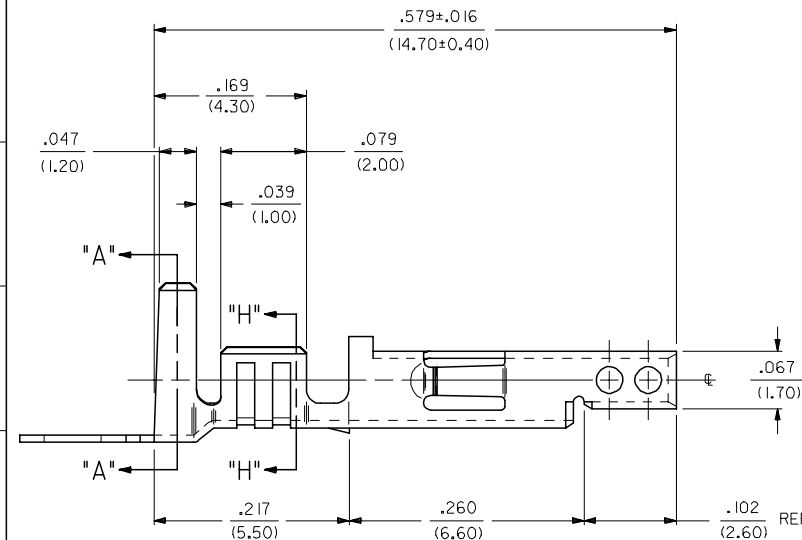

REMOVED 14 GA. FC NO: UCP2005-2552 DRW:NDUNNE 2005/06/01 CHKD:GOLGAR 2005/06/01 APPR: YMARGULL 2005/06/03	QUALITY SYMBOLS	GENERAL TOLERANCES (UNLESS SPECIFIED)	DIMENSION STYLE	SCALE	DESIGN UNITS	THIRD ANGLE PROJECTION																	
	$\nabla=0$ $\nabla=0$	<table border="1"> <tr> <th></th> <th>mm</th> <th>INCH</th> </tr> <tr> <td>4 PLACES</td> <td>± .10</td> <td>± .004</td> </tr> <tr> <td>3 PLACES</td> <td>± .15</td> <td>± .006</td> </tr> <tr> <td>2 PLACES</td> <td>± .25</td> <td>± .010</td> </tr> <tr> <td>1 PLACE</td> <td>± .36</td> <td>± .014</td> </tr> <tr> <td colspan="3">ANGULAR ±1/2°</td> </tr> </table>		mm	INCH	4 PLACES	± .10	± .004	3 PLACES	± .15	± .006	2 PLACES	± .25	± .010	1 PLACE	± .36	± .014	ANGULAR ±1/2°			IN/MM	10:1	INCH
	mm	INCH																					
4 PLACES	± .10	± .004																					
3 PLACES	± .15	± .006																					
2 PLACES	± .25	± .010																					
1 PLACE	± .36	± .014																					
ANGULAR ±1/2°																							
			DRAWN BY GEP	DATE 5/17/1990	TITLE MINI FIT JR TERMINAL FEMALE, CRIMP, TIN/NICKLE																		
			CHECKED BY RJV	DATE 5/17/1990	APPROVED BY RAS																		
			DATE 5/17/1990	MATERIAL NO. SD-5556-SP*																			
			DRAFT WHERE APPLICABLE MUST REMAIN WITHIN DIMENSIONS		SHEET NO. 1 OF 1																		
			THIS DRAWING CONTAINS INFORMATION THAT IS PROPRIETARY TO MOLEX INCORPORATED AND SHOULD NOT BE USED WITHOUT WRITTEN PERMISSION																				