

FEATURES

- Operates at supply voltages from 2 V to 30 V
- Works in step-up or step-down mode
- Very few external components required
- High frequency operation up to 400 kHz
- Low battery detector on-chip
- User-adjustable current limit
- Fixed and adjustable output voltage
- 8-lead PDIP, 8-lead SOIC, and 14-lead TSSOP packages
- Small inductors and capacitors

APPLICATIONS

- Notebook, palmtop computers
- Cellular telephones
- Hard disk drives
- Portable instruments
- Pagers

GENERAL DESCRIPTION

The ADP3000 is a versatile step-up/step-down switching regulator. It operates from an input supply voltage of 2 V to 12 V in step-up mode, and from 2 V to 30 V in step-down mode.

Operating in pulse frequency mode (PFM), the device consumes only 500 μ A, making it ideal for applications requiring low quiescent current. It delivers an output current of 180 mA at 3.3 V from a 2 V input in step-up mode, and an output current of 100 mA at 3 V from a 5 V input in step-down mode.

The ADP3000 operates at 400 kHz switching frequency. This allows the use of small external components (inductors and capacitors), making it convenient for space-constrained designs.

The auxiliary gain amplifier can be used as a low battery detector, linear regulator, undervoltage lockout, or error amplifier.

FUNCTIONAL BLOCK DIAGRAMS

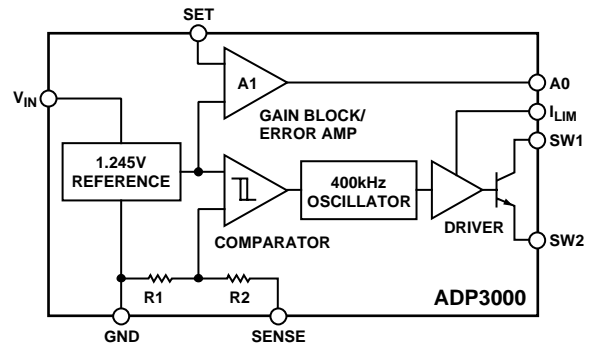

Figure 1.

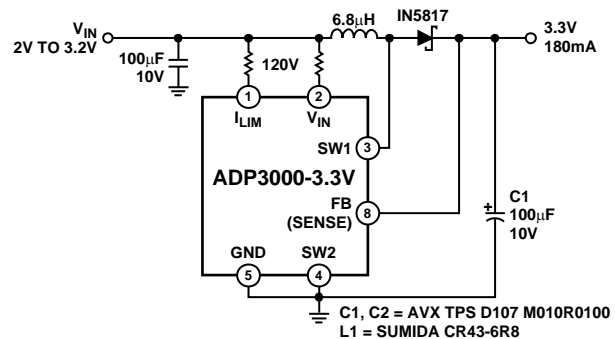

Figure 2. Typical Application

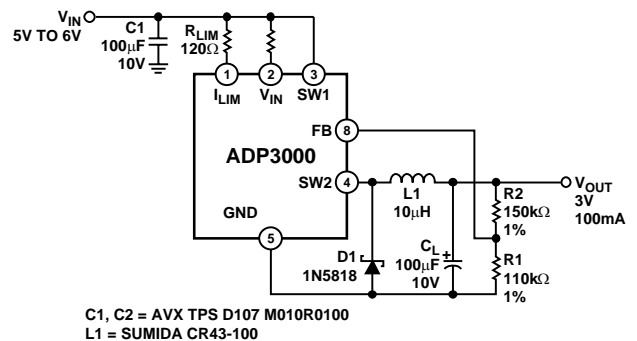

Figure 3. Step-Down Mode Operation

Rev. A

Information furnished by Analog Devices is believed to be accurate and reliable. However, no responsibility is assumed by Analog Devices for its use, nor for any infringements of patents or other rights of third parties that may result from its use. Specifications subject to change without notice. No license is granted by implication or otherwise under any patent or patent rights of Analog Devices. Trademarks and registered trademarks are the property of their respective owners.

TABLE OF CONTENTS

Specifications.....	3	Programming the Gain Block.....	11
Absolute Maximum Ratings.....	4	Power Transistor Protection Diode in Step-Down Configuration	11
ESD Caution.....	4	Thermal Considerations.....	11
Pin Configurations and Function Descriptions	5	Typical Application Circuits	13
Typical Performance Characteristics	6	Outline Dimensions	15
Theory of Operation	9	Ordering Guide	16
Applications Information	10		
Component Selection.....	10		
Programming the Switching Current Limit.....	10		

REVISION HISTORY

9/04—Data Sheet Changed from Rev. 0 to Rev. A

Added RU-14 Package	Universal
Changes to Table 4.....	10
Changes to Table 5.....	10
Updated Outline Dimensions	15
Changes to Ordering Guide	16

1/97—Revision 0: Initial Version

SPECIFICATIONS

$0^{\circ}\text{C} \leq T_A \leq +70^{\circ}\text{C}$, $V_{\text{IN}} = 3\text{ V}$, unless otherwise noted.¹

Table 1.

Parameter	Conditions	Symbol	ADP3000			Unit
			Min	Typ	Max	
INPUT VOLTAGE	Step-up mode	V_{IN}	2.0		12.6	V
	Step-down mode				30.0	V
SHUT-DOWN QUIESCENT CURRENT	$V_{\text{FB}} > 1.43\text{ V}$; $V_{\text{SENSE}} > 1.1 \times V_{\text{OUT}}$	I_{Q}		500		μA
COMPARATOR TRIP POINT VOLTAGE	ADP3000 ²		1.20	1.245	1.30	V
OUTPUT SENSE VOLTAGE	ADP3000-3.3 ³	V_{OUT}	3.135	3.3	3.465	V
	ADP3000-5 ³		4.75	5.00	5.25	V
	ADP3000-12 ³		11.40	12.00	12.60	V
COMPARATOR HYSTERESIS	ADP3000			8	12.5	mV
OUTPUT HYSTERESIS	ADP3000-3.3			32	50	mV
	ADP3000-5			32	50	mV
	ADP3000-12			75	120	mV
OSCILLATOR FREQUENCY		f_{OSC}	350	400	450	kHz
DUTY CYCLE	$V_{\text{FB}} < V_{\text{REF}}$	D	65	80		%
SWITCH-ON TIME	I_{LIM} tied to V_{IN} , $V_{\text{FB}} = 0$	t_{ON}	1.5	2	2.55	μs
SWITCH SATURATION VOLTAGE	$T_A = +25^{\circ}\text{C}$ Step-Up Mode $V_{\text{IN}} = 3.0\text{ V}$, $I_{\text{SW}} = 650\text{ mA}$ $V_{\text{IN}} = 5.0\text{ V}$, $I_{\text{SW}} = 1\text{ A}$ Step-Down Mode $V_{\text{IN}} = 12\text{ V}$, $I_{\text{SW}} = 650\text{ mA}$	V_{SAT}	0.5	0.75	V	
				0.8	1.1	V
				1.1	1.5	V
FEEDBACK PIN BIAS CURRENT	ADP3000 $V_{\text{FB}} = 0\text{ V}$	I_{FB}		160	330	nA
SET PIN BIAS CURRENT	$V_{\text{SET}} = V_{\text{REF}}$	I_{SET}		200	400	nA
GAIN BLOCK OUTPUT LOW	$I_{\text{SINK}} = 300\ \mu\text{A}$, $V_{\text{SET}} = 1.00\text{ V}$	V_{OL}		0.15	0.4	V
REFERENCE LINE REGULATION	$5\text{ V} \leq V_{\text{IN}} \leq 30\text{ V}$			0.02	0.15	%/V
	$2\text{ V} \leq V_{\text{IN}} \leq 5\text{ V}$			0.2	0.6	%/V
GAIN BLOCK GAIN	$R_L = 100\text{ k}\Omega^4$	A_V	1000	6000		V/V
GAIN BLOCK CURRENT SINK	$V_{\text{SET}} \leq 1\text{ V}$	I_{SINK}		300		μA
CURRENT LIMIT	$220\ \Omega$ from I_{LIM} to V_{IN}	I_{LIM}		400		mA
CURRENT LIMIT TEMPERATURE COEFFICIENT				-0.3		%/ $^{\circ}\text{C}$
SWITCH-OFF LEAKAGE CURRENT	Measured at SW1 pin $V_{\text{SW1}} = 12\text{ V}$, $T_A = +25^{\circ}\text{C}$			1	10	μA
MAXIMUM EXCURSION BELOW GND	$T_A = +25^{\circ}\text{C}$ $I_{\text{SW1}} \leq 10\ \mu\text{A}$, switch off			-400	-350	mV

¹ All limits at temperature extremes are guaranteed via correlation using standard statistical methods.

² This specification guarantees that both the high and low trip points of the comparator fall within the 1.20 V to 1.30 V range.

³ The output voltage waveform will exhibit a saw-tooth shape due to the comparator hysteresis. The output voltage on the fixed output versions will always be within the specified range.

⁴ 100 k Ω resistor connected between a 5 V source and the AO pin.

ADP3000

ABSOLUTE MAXIMUM RATINGS

Table 2.

Parameter	Rating
Input Supply Voltage, Step-Up Mode	15 V
Input Supply Voltage, Step-Down Mode	36 V
SW1 Pin Voltage	50 V
SW2 Pin Voltage	-0.5 V to V_{IN}
Feedback Pin Voltage (ADP3000)	5.5 V
Switch Current	1.5 A
Maximum Power Dissipation	500 mW
Operating Temperature Range	0°C to +70°C
Storage Temperature Range	-65°C to +150°C
Lead Temperature (Soldering, 10 s)	300°C
Thermal Impedance	
R-8	170°C/W
RU-14	150°C/W
N-8	120°C/W

Stresses above those listed under Absolute Maximum Ratings may cause permanent damage to the device. This is a stress rating only; functional operation of the device at these or any other conditions above those indicated in the operational section of this specification is not implied. Exposure to Absolute Maximum Rating conditions for extended periods may affect device reliability.

ESD CAUTION

ESD (electrostatic discharge) sensitive device. Electrostatic charges as high as 4000 V readily accumulate on the human body and test equipment and can discharge without detection. Although this product features proprietary ESD protection circuitry, permanent damage may occur on devices subjected to high energy electrostatic discharges. Therefore, proper ESD precautions are recommended to avoid performance degradation or loss of functionality.



PIN CONFIGURATIONS AND FUNCTION DESCRIPTIONS

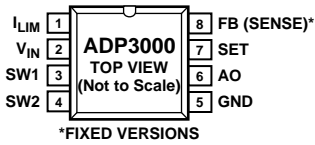

Figure 4. 8-Lead Plastic DIP (N-8)

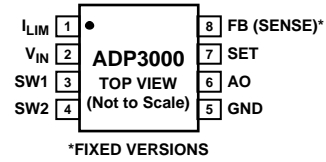

Figure 6. 8-Lead SOIC (R-8)

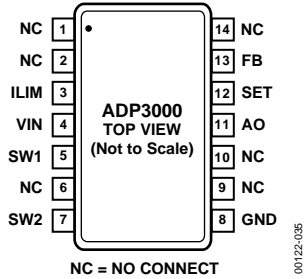

Figure 5. 14-lead TSSOP (RU-14)

Table 3. Pin Function Descriptions

Mnemonic	Function
I_{LIM}	For normal conditions, connect to V_{IN} . When lower current is required, connect a resistor between I_{LIM} and V_{IN} . To limit the switch current to 400 mA, connect a 220 Ω resistor.
V_{IN}	Input Voltage.
SW1	Collector of Power Transistor. For step-down configuration, connect to V_{IN} . For step-up configuration, connect to an inductor/diode.
SW2	Emitter of Power Transistor. For step-down configuration, connect to inductor/diode. For step-up configuration, connect to ground. Do not allow pin to go more than a diode drop below ground.
GND	Ground.
AO	Auxiliary Gain Block (GB) Output. Open collector can sink 300 μ A. This pin can be left open if not used.
SET	Auxiliary Gain Amplifier Input. The amplifier's positive input is connected to the SET pin, and its negative input is connected to the 1.245 V reference. This pin can be left open if not used.
FB/SENSE	On the ADP3000 (adjustable) version, this pin is connected to the comparator input. On the ADP3000-3.3, the ADP3000-5, and the ADP3000-12, the pin goes directly to the internal resistor divider that sets the output voltage.

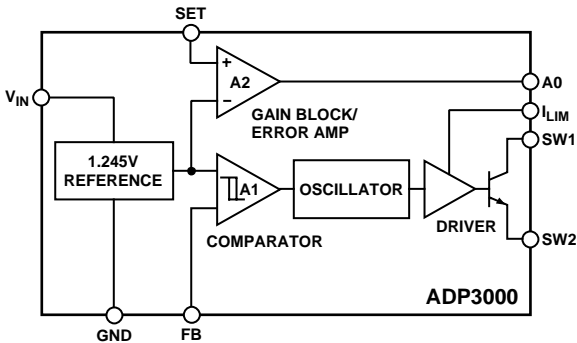

Figure 7. Functional Block Diagram for Adjustable Version

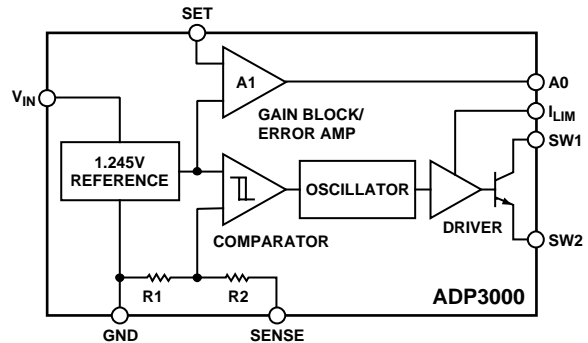

Figure 8. Functional Block Diagram for Fixed Version

TYPICAL PERFORMANCE CHARACTERISTICS

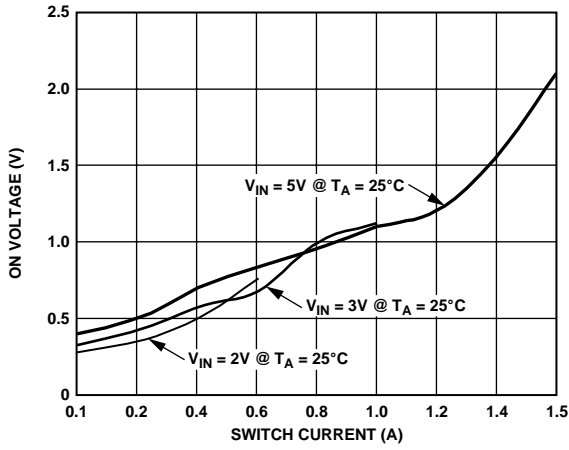

Figure 9. Switch-On Voltage vs. Switch Current in Step-Up Mode

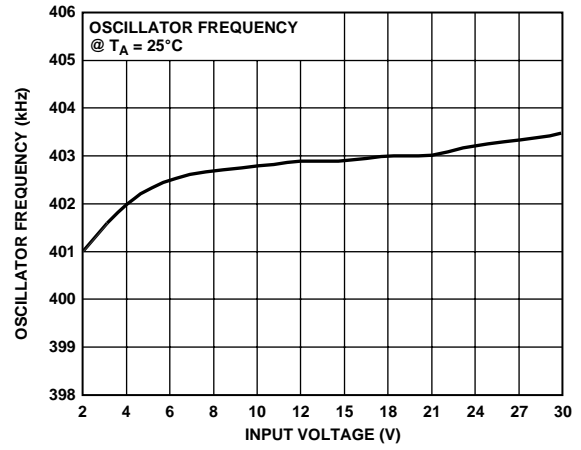

Figure 12. Oscillator Frequency vs. Input Voltage

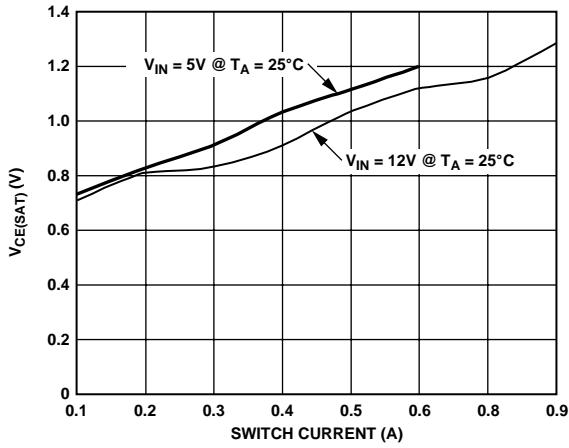

Figure 10. Saturation Voltage vs. Switch Current in Step-Down Mode

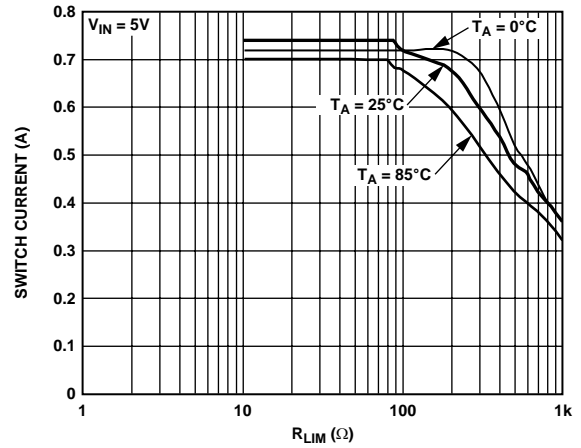

Figure 13. Maximum Switch Current vs. R_{LIM} in Step-Down Mode (5 V)

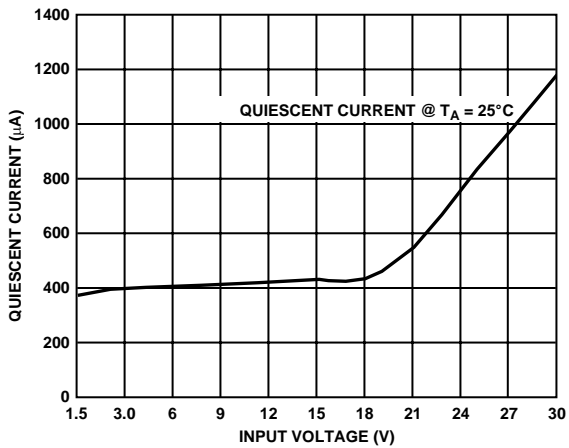

Figure 11. Quiescent Current vs. Input Voltage

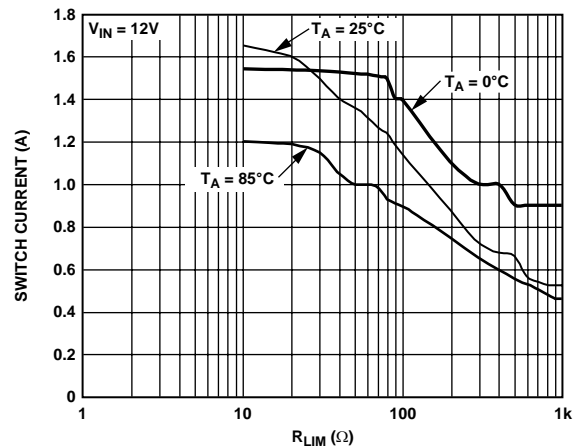

Figure 14. Maximum Switch Current vs. R_{LIM} in Step-Down Mode (12 V)

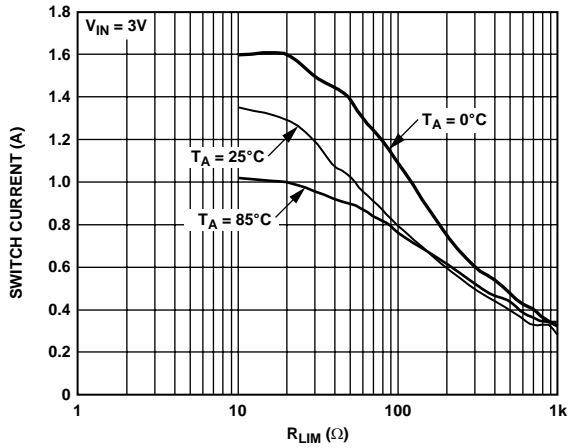

Figure 15. Maximum Switch Current vs. R_{LIM} in Step-Up Mode (3 V)

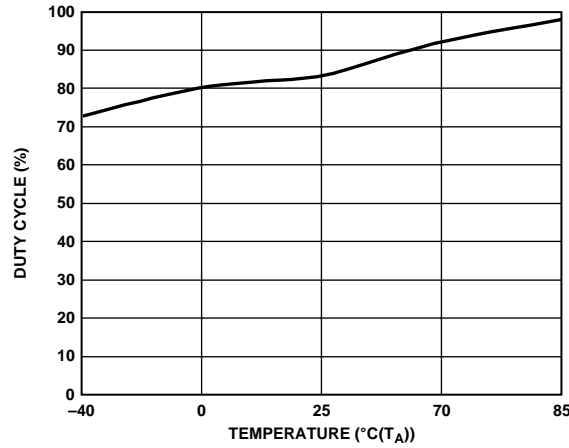

Figure 18. Duty Cycle vs. Temperature

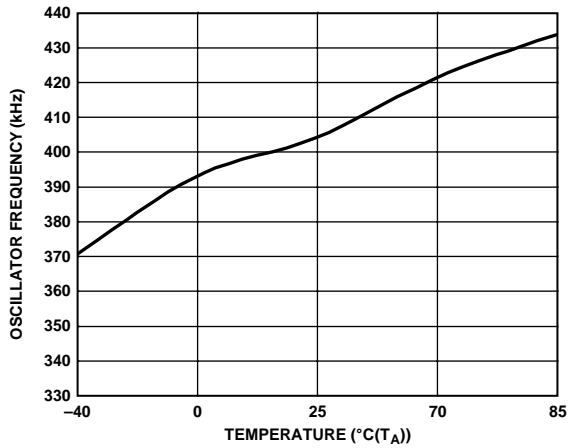

Figure 16. Oscillator Frequency vs. Temperature

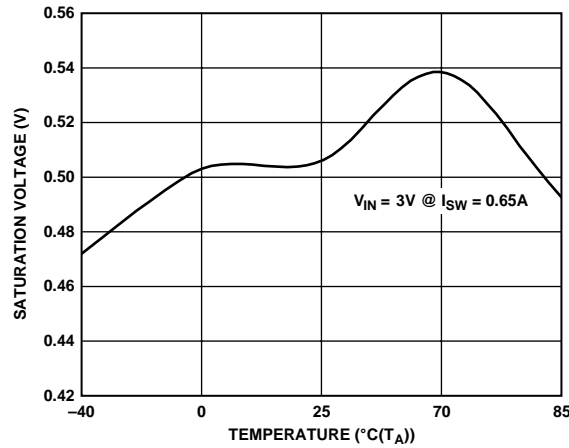

Figure 19. Saturation Voltage vs. Temperature in Step-Up Mode

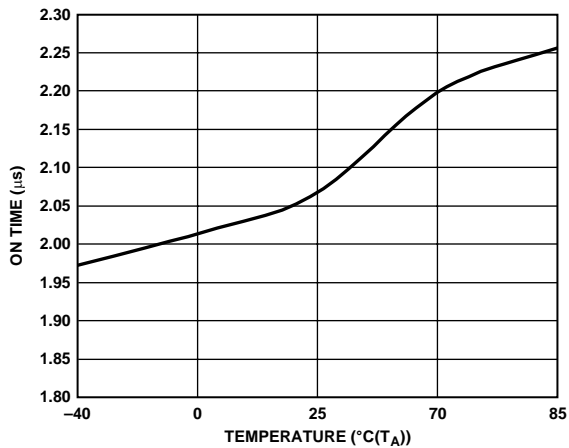

Figure 17. Switch-On Time vs. Temperature

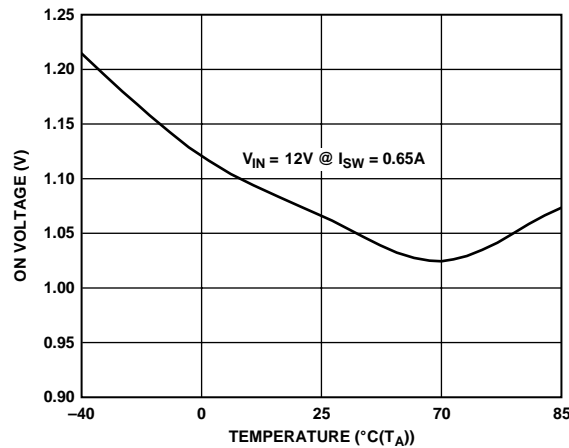
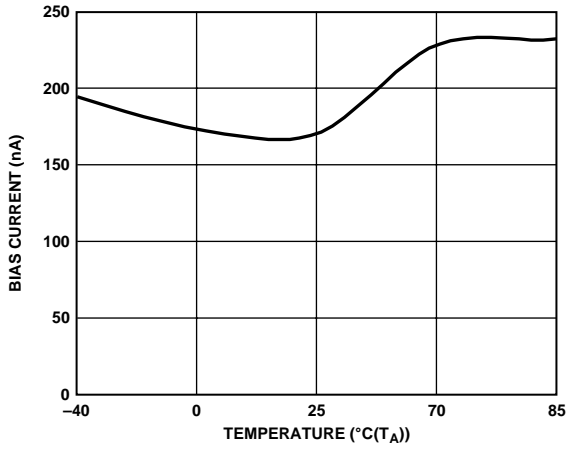
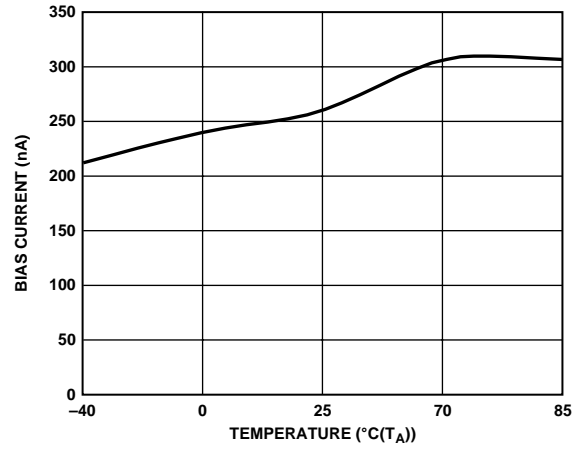

Figure 20. Switch-On Voltage vs. Temperature in Step-Down Mode



00122-020

Figure 21. Feedback Bias Current vs. Temperature



00122-022

Figure 23. Set Pin Bias Current vs. Temperature

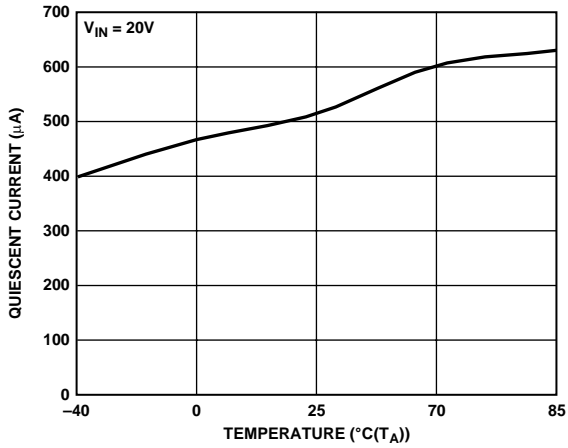

00122-021

Figure 22. Quiescent Current vs. Temperature

THEORY OF OPERATION

The ADP3000 is a versatile, high frequency, switch mode power supply (SMPS) controller. The regulated output voltage can be greater than the input voltage (in boost or step-up mode) or less than the input voltage (in buck or step-down mode). This device uses a gated oscillator technique to provide high performance with low quiescent current.

Figure 7 is a functional block diagram of the ADP3000. The internal 1.245 V reference is connected to one input of the comparator, and the other input is externally connected (via the FB pin) to a resistor divider, which is connected to the regulated output. When the voltage at the FB pin falls below 1.245 V, the 400 kHz oscillator turns on. The ADP3000 internal oscillator typically provides a 1.7 μ s on time and a 0.8 μ s off time. A driver amplifier provides base drive to the internal power switch, and the switching action raises the output voltage. When the voltage at the FB pin exceeds 1.245 V, the oscillator shuts off. While the oscillator is off, the ADP3000 quiescent current is only 500 μ A. The comparator's hysteresis ensures loop stability without requiring external components for frequency compensation.

The maximum current in the internal power switch is set by connecting a resistor between V_{IN} and the I_{LIM} pin. When the maximum current is exceeded, the switch is turned off. The current limit circuitry has a time delay of about 0.3 μ s. If an external resistor is not used, connect I_{LIM} to V_{IN} . This yields the maximum feasible current limit. Further information on I_{LIM} is included in the Applications Information section.

An uncommitted gain block on the ADP3000 can be connected as a low battery detector. The inverting input of the gain block is internally connected to the 1.245 V reference. The noninverting input is available at the SET pin. A resistor divider, connected between V_{IN} and GND with the junction connected to the SET pin, causes the AO output to go low when the low battery set point is exceeded. The AO output is an open collector NPN transistor that can sink in excess of 300 μ A.

The ADP3000 provides external connections for both the collector and the emitter of its internal power switch, permitting both step-up and step-down modes of operation. For the step-up mode, the emitter (Pin SW2) is connected to GND, and the collector (Pin SW1) drives the inductor. For step-down mode, the emitter drives the inductor, while the collector is connected to V_{IN} .

The output voltage of the ADP3000 is set with two external resistors. Three fixed voltage models are also available: ADP3000-3.3 (3.3 V), ADP3000-5 (5 V), and ADP3000-12 (12 V). The fixed voltage models include laser-trimmed, voltage-setting resistors on the chip. On the fixed voltage models of the ADP3000, simply connect the feedback pin (Pin 8) directly to the output voltage.

APPLICATIONS INFORMATION

COMPONENT SELECTION

Inductor Selection

For most applications, the inductor used with the ADP3000 falls in the range of 4.7 μH to 33 μH . Table 4 shows recommended inductors and their vendors.

When selecting an inductor for the ADP3000, it is very important to make sure the inductor is able to handle a current higher than the ADP3000's current limit, without becoming saturated.

As a general rule, powdered iron cores saturate softly, whereas Ferrite cores saturate abruptly. Rod and *open* drum core geometry inductors saturate gradually. Inductors that saturate gradually are easier to use. Even though rod and drum core inductors are attractive in both price and physical size, they must be used with care because they have high magnetic radiation. When minimizing EMI is critical, toroid and *closed* drum core geometry inductors should be used.

In addition, inductor dc resistance causes power loss. To minimize power loss, it is best to use an inductor with a dc resistance lower than 0.2 Ω .

Table 4. Recommended Inductors

Vendor	Series	Core Type	Phone Number
Coiltronics	OCTAPAC	Toroid	(561) 752-5000
Coiltronics	UNIPAC	Open	(561) 752-5000
Sumida	CR43, CR54	Open	(847) 545-6700
Sumida	CDRH6D28, CDRH73, CDRH64	Semi-Closed Geometry	(847) 545-6700

Capacitor Selection

For most applications, the capacitor used with the ADP3000 falls in the range of 33 μF to 220 μF . Table 5 shows recommended capacitors and their vendors.

For input and output capacitors, use low ESR type capacitors for best efficiency and lowest ripple. Recommended capacitors include the AVX TPS series, the Sprague 595D series, the Panasonic HFQ series, and the Sanyo OS-CON series.

When selecting a capacitor, it is important to make sure the maximum capacitor ripple current rms rating is higher than the ADP3000's rms switching current.

It is best to protect the input capacitor from high turn-on current charging surges by derating the capacitor voltage by 2:1. For very low input or output voltage ripple requirements, use capacitors with very low ESR, such as the Sanyo OS-CON series. Alternatively, two or more tantalum capacitors can be used in parallel.

Table 5. Recommended Capacitors

Vendor	Series	Type	Phone Number
AVX	TPS	Surface Mount	(843) 448-9411
Sanyo	OS-CON	Through Hole	(619) 661-6835
Sprague	595D	Surface Mount	(603) 224-1961
Panasonic	HFQ	Through Hole	(800) 344-2112

Diode Selection

The ADP3000's high switching speed demands the use of Schottky diodes. Suitable choices include the 1N5817, the 1N5818, the 1N5819, the MBR5120LT3, and the MBR0520LT1. Fast recovery diodes are not recommended because their high forward drop lowers efficiency. General-purpose and small-signal diodes should be avoided as well.

PROGRAMMING THE SWITCHING CURRENT LIMIT

The ADP3000's R_{LIM} pin permits the cycle-by-cycle switch current limit to be programmed with a single external resistor. This feature offers major advantages that ultimately decrease the component's cost and the PCB's real estate. First, the R_{LIM} pin allows the ADP3000 to use low value, low saturation current and physically small inductors. Additionally, it allows for a physically small surface-mount tantalum capacitor with a typical ESR of 0.1 Ω . With this capacitor, it achieves an output ripple as low as 40 mV to 80 mV, as well as a low input ripple.

The current limit is usually set to approximately 3 to 5 times the full load current for boost applications, and about 1.5 to 3 times the full load current in buck applications.

The internal structure of the I_{LIM} circuit is shown in Figure 24. Q1, the ADP3000's internal power switch, is paralleled by sense transistor Q2. The relative sizes of Q1 and Q2 are scaled so that I_{Q2} is 0.5% of I_{Q1} . Current flows to Q2 through both the R_{LIM} resistor and an internal 80 Ω resistor. The voltage on these two resistors biases the base-emitter junction of the oscillator-disable transistor, Q3. When the voltage across R1 and R_{LIM} exceeds 0.6 V, Q3 turns on and terminates the output pulse. If only the 80 Ω internal resistor is used (when the I_{LIM} pin is connected directly to V_{IN}), the maximum switch current is 1.5 A. Figure 13, Figure 14, and Figure 15 give values for lower current limit levels.

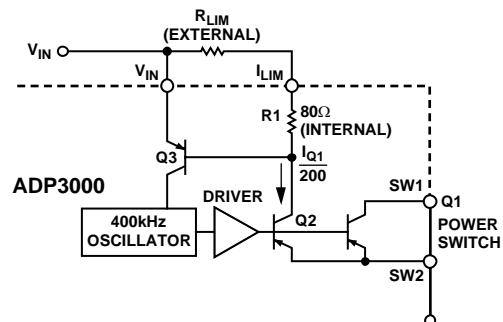

Figure 24. ADP3000 Current Limit Operation

The delay through the current limiting circuit is approximately 0.3 μ s. If the switch-on time is reduced to less than 1.7 μ s, accuracy of the current trip point is reduced as well. An attempt to program a switch-on time of 0.3 μ s or less produces spurious responses in the switch-on time. However, the ADP3000 still provides a properly regulated output voltage.

PROGRAMMING THE GAIN BLOCK

The ADP3000's gain block can be used as a low battery detector, an error amplifier, or a linear post regulator. It consists of an op amp with PNP inputs and an open-collector NPN output. The inverting input is internally connected to the 1.245 V reference, and the noninverting input is available at the SET pin. The NPN output transistor sinks in excess of 300 μ A.

Figure 25 shows the gain block configured as a low battery monitor. Set Resistors R1 and R2 to high values to reduce quiescent current, but not so high that bias current in the SET input causes large errors. A value of 33 k Ω for R2 is a good compromise. The value for R1 is then calculated as follows:

$$R1 = \frac{V_{LOBATT} - 1.245 \text{ V}}{\frac{1.245 \text{ V}}{R2}}$$

where V_{LOBATT} is the desired low battery trip point.

Because the gain block output is an open-collector NPN, a pull-up resistor should be connected to the positive logic power supply.

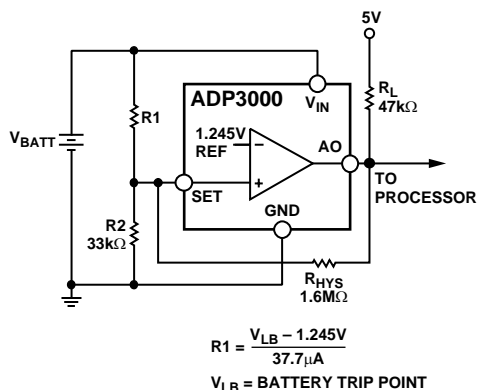

Figure 25. Setting the Low Battery Detector Trip Point

The circuit of Figure 25 may produce multiple pulses when approaching the trip point due to noise coupled into the SET input. To prevent multiple interrupts to the digital logic, add hysteresis to the circuit. Resistor R_{HYS} , with a value of 1 M Ω to 10 M Ω , provides the hysteresis. The addition of R_{HYS} alters the trip point slightly, changing the new value for R1 to

$$R1 = \frac{V_{LOBATT} - 1.245 \text{ V}}{\left(\frac{1.245 \text{ V}}{R2}\right) - \left(\frac{V_L - 1.245 \text{ V}}{R_L + R_{HYS}}\right)}$$

where:

V_L is the logic power supply voltage.

R_L is the pull-up resistor.

R_{HYS} creates the hysteresis.

POWER TRANSISTOR PROTECTION DIODE IN STEP-DOWN CONFIGURATION

When operating the ADP3000 in step-down mode with the switch off, the output voltage is impressed across the internal power switch's emitter-base junction. When the output voltage is set to higher than 6 V, a Schottky diode must be placed in a series with SW2 to protect the switch. Figure 26 shows the proper way to place D2, the protection diode. The selection of this diode is identical to the step-down commuting diode (refer to the Diode Selection section).

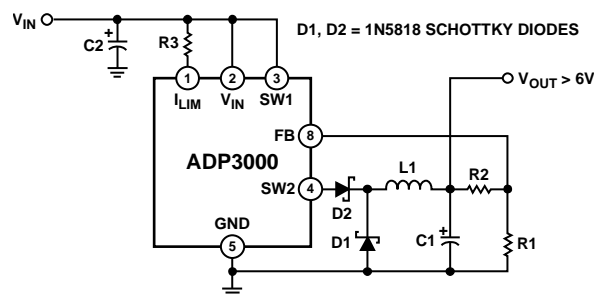

Figure 26. Step-Down Mode $V_{OUT} > 6.0 \text{ V}$

THERMAL CONSIDERATIONS

Power dissipation internal to the ADP3000 can be approximated with the following equations.

Step-Up

$$P_D = \left[I_{SW}^2 R + \frac{V_{IN} I_{SW}}{\beta} \right] D \left[1 - \frac{V_{IN}}{V_O} \right] \left[\frac{4I_O}{I_{SW}} \right] + [I_Q][V_{IN}]$$

where:

I_{SW} is I_{LIMIT} when the current limit is programmed externally; otherwise, I_{SW} is the maximum inductor current.

V_O is the output voltage.

I_O is the output current.

V_{IN} is the input voltage.

R is 1 Ω (typical $R_{CE(SAT)}$).

D is 0.75 (typical duty ratio for a single switching cycle).

I_Q is 500 μ A (typical shutdown quiescent current).

$\beta = 30$ (typical forced beta).

Step-Down

$$P_D = \left[I_{SW} V_{CESAT} \left(1 + \frac{1}{\beta} \right) \left[\frac{V_O}{V_{IN} - V_{CE(SAT)}} \right] \left[\frac{2 I_O}{I_{SW}} \right] + [I_Q][V_{IN}] \right]$$

where:

I_{SW} is I_{LIMIT} when the current limit is programmed externally; otherwise, I_{SW} is the maximum inductor current.

$V_{CE(SAT)}$ is 1.2 V (typical value). Check this value by applying I_{SW} to Figure 10.

V_O is the output voltage.

I_O is the output current.

V_{IN} is the input voltage.

D is 0.75 (typical duty ratio for a single switching cycle).

I_Q is 500 μ A (typical shutdown quiescent current).

β is 30 (typical forced beta).

The temperature rise can be calculated using the following equation:

$$\Delta T = P_D \times \theta_{JA}$$

where:

ΔT is temperature rise.

P_D is device power dissipation.

θ_{JA} is thermal resistance (junction-to-ambient).

For example, consider a boost converter with the following specifications:

V_{IN} is 2 V.

V_O is 3.3 V.

I_O is 180 mA.

I_{SW} is 0.8 A (externally programmed).

Using the step-up power dissipation equation:

$$P_D = \left[0.8^2 \times 1 + \frac{(2)(0.8)}{30} \right] [0.75] \left[1 - \frac{2}{3.3} \right] \left[\frac{(4)0.18}{0.8} \right] + [500 E - 6][2]$$

ΔT is 185 mW (170°C/W) = 31.5°C, using the R-8 package.

ΔT is 185 mW (120°C/W) = 22.2°C, using the N-8 package.

At a 70°C ambient, the die temperature would be 101.45°C for the R-8 package and 92.2°C for the N-8 package. These junction temperatures are well below the maximum recommended junction temperature of 125°C.

Finally, the die temperature can be decreased up to 20% by using a large metal ground plate as ground pickup for the ADP3000.

TYPICAL APPLICATION CIRCUITS

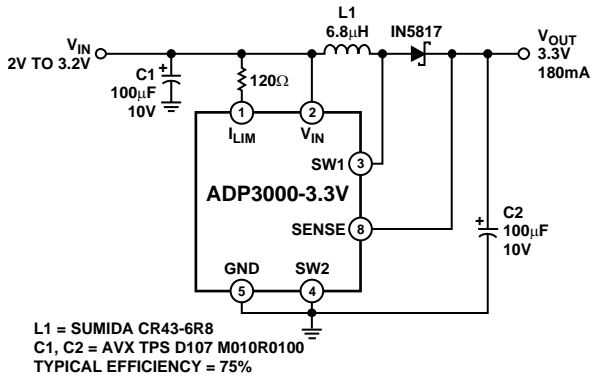

Figure 27. 2 V to 3.3 V/180 mA Step-Up Converter

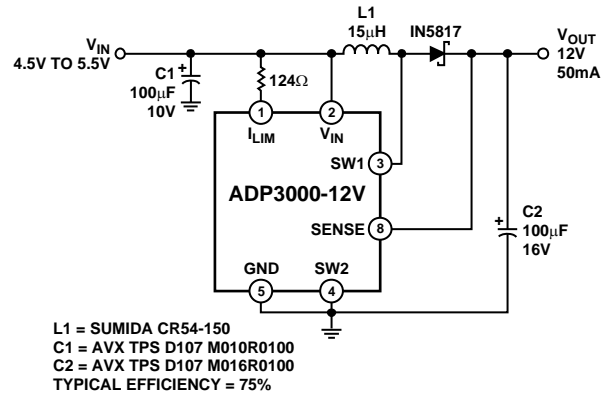

Figure 30. 4.5 V to 12 V/50 mA Step-Up Converter

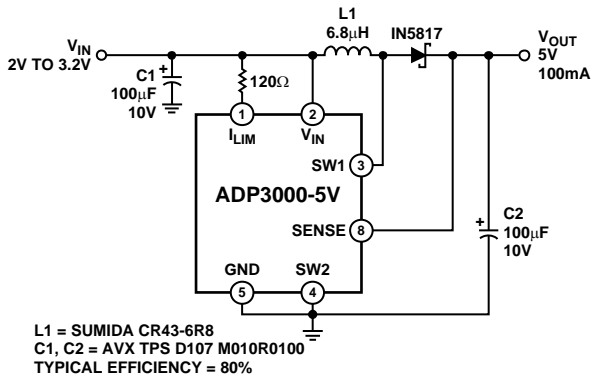

Figure 28. 2 V to 5 V/100 mA Step-Up Converter

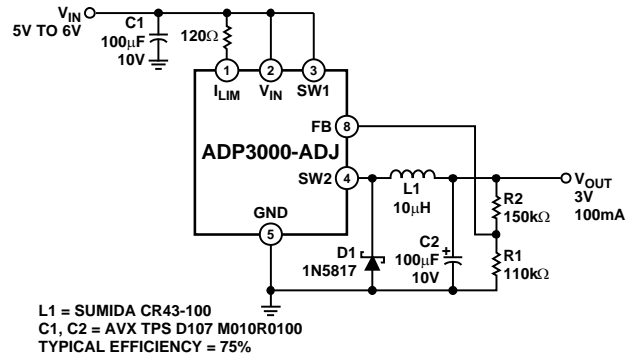

Figure 31. 5 V to 3 V/100 mA Step-Down Converter

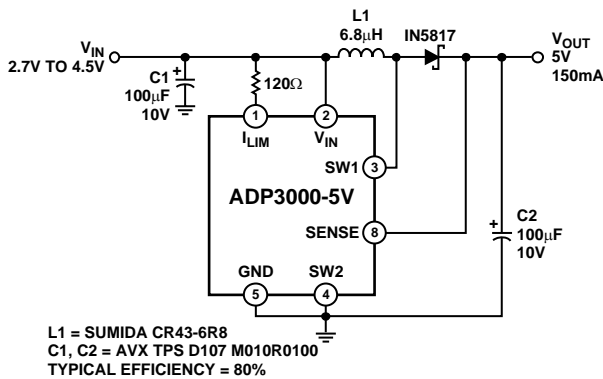

Figure 29. 2.7 V to 5 V/150 mA Step-Up Converter

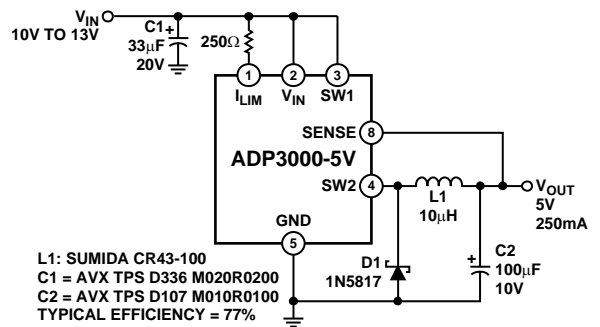

Figure 32. 10 V to 5 V/250 mA Step-Down Converter

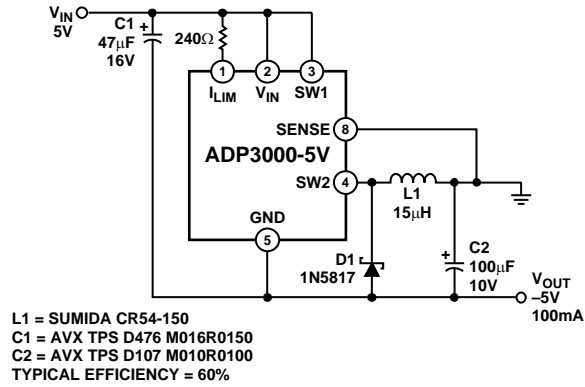

Figure 33. 5 V to -5 V/100 mA Inverter

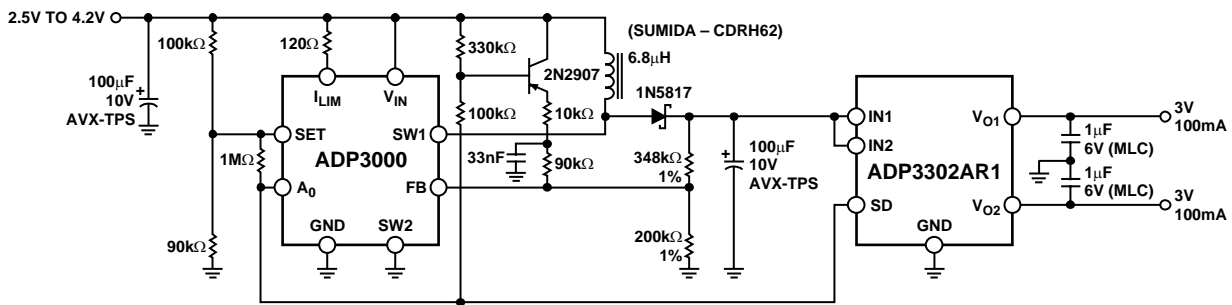

Figure 34. 1 Cell Li-Ion to 3 V/200 mA Converter with Shut-Down at $V_{IN} \leq 2.5$ V

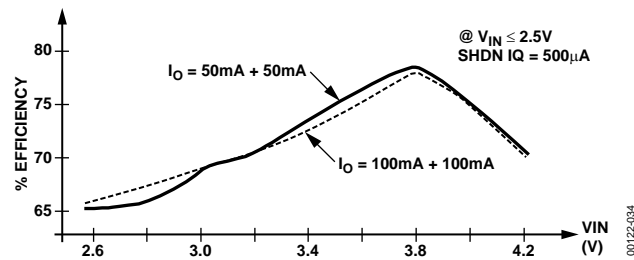
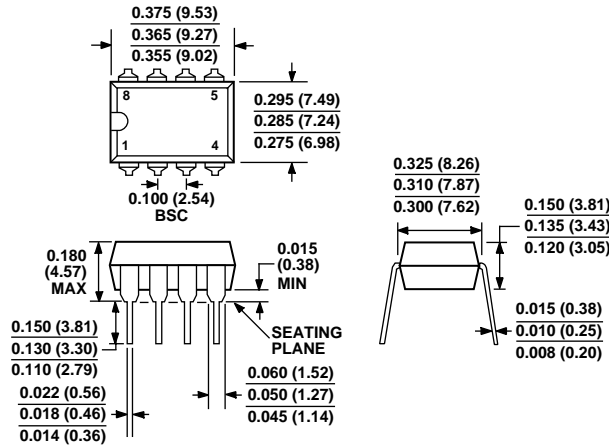

Figure 35. Typical Efficiency of the Circuit of Figure 34

OUTLINE DIMENSIONS



COMPLIANT TO JEDEC STANDARDS MO-095AA
CONTROLLING DIMENSIONS ARE IN INCHES; MILLIMETER DIMENSIONS (IN PARENTHESES) ARE ROUNDED-OFF INCH EQUIVALENTS FOR REFERENCE ONLY AND ARE NOT APPROPRIATE FOR USE IN DESIGN

Figure 36. 8-Lead Plastic Dual In-Line Package [PDIP]
(N-8)
Dimensions shown in inches and (millimeters)

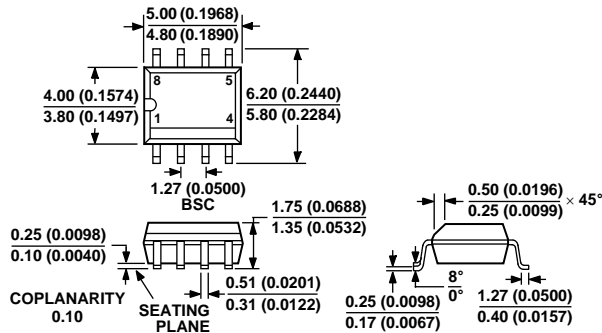

COMPLIANT TO JEDEC STANDARDS MS-012AA
CONTROLLING DIMENSIONS ARE IN MILLIMETERS; INCH DIMENSIONS (IN PARENTHESES) ARE ROUNDED-OFF MILLIMETER EQUIVALENTS FOR REFERENCE ONLY AND ARE NOT APPROPRIATE FOR USE IN DESIGN

Figure 37. 8-Lead Standard Small Outline Package [SOIC]
Narrow Body
(R-8)
Dimensions shown in millimeters and (inches)

ADP3000

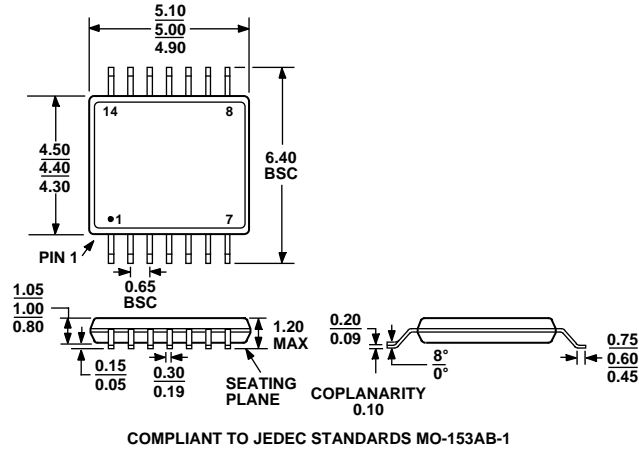

Figure 38. 14-Lead Thin Shrink Small Outline Package [TSSOP]
(RU-14)
Dimensions shown in millimeters

ORDERING GUIDE

Model	Output Voltage	Temperature Range	Package Description	Package Option
ADP3000AN	Adjustable	-40°C to +85°C	8-lead plastic DIP	N-8
ADP3000AN-3.3	3.3 V	-40°C to +85°C	8-lead plastic DIP	N-8
ADP3000AN-5	5 V	-40°C to +85°C	8-lead plastic DIP	N-8
ADP3000AN-12	12 V	-40°C to +85°C	8-lead plastic DIP	N-8
ADP3000AR	Adjustable	-40°C to +85°C	8-lead SOIC	R-8
ADP3000AR-REEL	Adjustable	-40°C to +85°C	8-lead SOIC	R-8
ADP3000AR-3.3	3.3 V	-40°C to +85°C	8-lead SOIC	R-8
ADP3000AR-3.3-REEL	3.3 V	-40°C to +85°C	8-lead SOIC	R-8
ADP3000AR-5	5 V	-40°C to +85°C	8-lead SOIC	R-8
ADP3000AR-5-REEL	5 V	-40°C to +85°C	8-lead SOIC	R-8
ADP3000AR-12	12 V	-40°C to +85°C	8-lead SOIC	R-8
ADP3000AR-12-REEL	12 V	-40°C to +85°C	8-lead SOIC	R-8
ADP3000ARU	Adjustable	-40°C to +85°C	14-lead TSSOP	RU-14
ADP3000ARU-REEL	Adjustable	-40°C to +85°C	14-lead TSSOP	RU-14