

DRAM MODULE

KMM372C400CK/CS & KMM372C410CK/CS with Fast Page Mode

4Mx72 DRAM DIMM with ECC using 4Mx4, 4K & 2K Refresh, 5V

GENERAL DESCRIPTION

The Samsung KMM372C40(1)0C is a 4Mx72bits Dynamic RAM high density memory module. The Samsung KMM372C40(1)0C consists of eighteen CMOS 4Mx4bits DRAMs in SOJ/TSOP-II 300mil package, and two 16bits driver IC in 48pin TSSOP package mounted on a 168-pin glass-epoxy substrate. A 0.1 or 0.22uF decoupling capacitor is mounted on the printed circuit board for each DRAM. The KMM372C40(1)0C is a Dual In-line Memory Module and is intended for mounting into 168-pin edge connector sockets.

PERFORMANCE RANGE

Speed	t _{TRAC}	t _{CAC}	t _{RC}
-5	50ns	18ns	90ns
-6	60ns	20ns	110ns

FEATURES

- Part Identification
 - KMM372C400CK (4096 cycles/64ms Ref., SOJ)
 - KMM372C400CS (4096 cycles/64ms Ref., TSOP)
 - KMM372C410CK (2048 cycles/32ms Ref., SOJ)
 - KMM372C410CS (2048 cycles/32ms Ref., TSOP)
- Fast Page Mode Operation
- \overline{CAS} -before- \overline{RAS} Refresh capability
- \overline{RAS} -only and Hidden refresh capability
- TTL compatible inputs and outputs
- Single 5V±10% power supply
- JEDEC standard pinout & Buffered PDpin
- Buffered input except \overline{RAS} and DQ
- PCB : Height(1000mil), double sided component

PIN CONFIGURATIONS

Pin	Front	Pin	Front	Pin	Front	Pin	Back	Pin	Back	Pin	Back
1	V _{SS}	29	RSVD	57	DQ22	85	V _{SS}	113	RSVD	141	DQ58
2	DQ0	30	$\overline{RAS0}$	58	DQ23	86	DQ36	114	* $\overline{RAS1}$	142	DQ59
3	DQ1	31	$\overline{OE0}$	59	V _{CC}	87	DQ37	115	RFU	143	V _{CC}
4	DQ2	32	V _{SS}	60	DQ24	88	DQ38	116	V _{SS}	144	DQ60
5	DQ3	33	A0	61	RFU	89	DQ39	117	A1	145	RFU
6	V _{CC}	34	A2	62	RFU	90	V _{CC}	118	A3	146	RFU
7	DQ4	35	A4	63	RFU	91	DQ40	119	A5	147	RFU
8	DQ5	36	A6	64	RFU	92	DQ41	120	A7	148	RFU
9	DQ6	37	A8	65	DQ25	93	DQ42	121	A9	149	DQ61
10	DQ7	38	A10	66	DQ26	94	DQ43	122	A11	150	DQ62
11	DQ8	39	*A12	67	DQ27	95	DQ44	123	*A13	151	DQ63
12	V _{SS}	40	V _{CC}	68	V _{SS}	96	V _{SS}	124	V _{CC}	152	V _{SS}
13	DQ9	41	RFU	69	DQ28	97	DQ45	125	RFU	153	DQ64
14	DQ10	42	RFU	70	DQ29	98	DQ46	126	B0	154	DQ65
15	DQ11	43	V _{SS}	71	DQ30	99	DQ47	127	V _{SS}	155	DQ66
16	DQ12	44	$\overline{OE1}$	72	DQ31	100	DQ48	128	RFU	156	DQ67
17	DQ13	45	$\overline{RAS1}$	73	V _{CC}	101	DQ49	129	* $\overline{RAS2}$	157	V _{CC}
18	V _{CC}	46	$\overline{CAS1}$	74	DQ32	102	V _{CC}	130	* $\overline{CAS2}$	158	DQ68
19	DQ14	47	RSVD	75	DQ33	103	DQ50	131	RSVD	159	DQ69
20	DQ15	48	$\overline{W1}$	76	DQ34	104	DQ51	132	PDE	160	DQ70
21	DQ16	49	V _{CC}	77	DQ35	105	DQ52	133	V _{CC}	161	DQ71
22	DQ17	50	RSVD	78	V _{SS}	106	DQ53	134	RSVD	162	V _{SS}
23	V _{SS}	51	RSVD	79	PD1	107	V _{SS}	135	RSVD	163	PD2
24	RSVD	52	DQ18	80	PD3	108	RSVD	136	DQ54	164	PD4
25	RSVD	53	DQ19	81	PD5	109	RSVD	137	DQ55	165	PD6
26	V _{CC}	54	V _{SS}	82	PD7	110	V _{CC}	138	V _{SS}	166	PD8
27	$\overline{W0}$	55	DQ20	83	ID0	111	RFU	139	DQ56	167	ID1
28	$\overline{CAS0}$	56	DQ21	84	V _{CC}	112	* $\overline{CAS3}$	140	DQ57	168	V _{CC}

NOTE : A11 is used for only KMM372C400CK/CS (4K ref.)

PD Note : PD & ID Terminals must each be pulled up through a register to V_{CC} at the next higher level assembly. PDs will be either open (NC) or driven to V_{SS} via on-board buffer circuits.

ID Note : IDs will be either open (NC) or connected directly to V_{SS} without a buffer.

PIN NAMES

Pin Names	Function
A0, B0, A1 - A11	Address Input (4K Ref)
A0, B0, A1 - A10	Address Input (2K Ref)
DQ0 - DQ71	Data In/Out
$\overline{W0}$, $\overline{W1}$	Read/Write Enable
\overline{OE} , $\overline{OE1}$	Output Enable
$\overline{RAS0}$, $\overline{RAS1}$	Row Address Strobe
$\overline{CAS0}$, $\overline{CAS1}$	Column Address Strobe
V _{CC}	Power(+5V)
V _{SS}	Ground
NC	No Connection
PDE	Presence Detect Enable
PD1 - 8	Presence Detect
ID0 - 1	ID bit
RSVD	Reserved Use
RFU	Reserved for Future Use

Pins marked "*" are not used in this module.

PD & ID Table

Pin	50NS	60NS
PD1	1	1
PD2	1	1
PD3	0	0
PD4	1	1
PD5	0	0
PD6	0	1
PD7	0	1
PD8	0	0
ID0	0	0
ID1	0	0

PD : 0 for Vol of Drive IC & 1 for N.C

ID : 0 for V_{SS} & 1 for N.C

DRAM MODULE

KMM372C400CK/CS
KMM372C410CK/CS

FUNCTIONAL BLOCK DIAGRAM

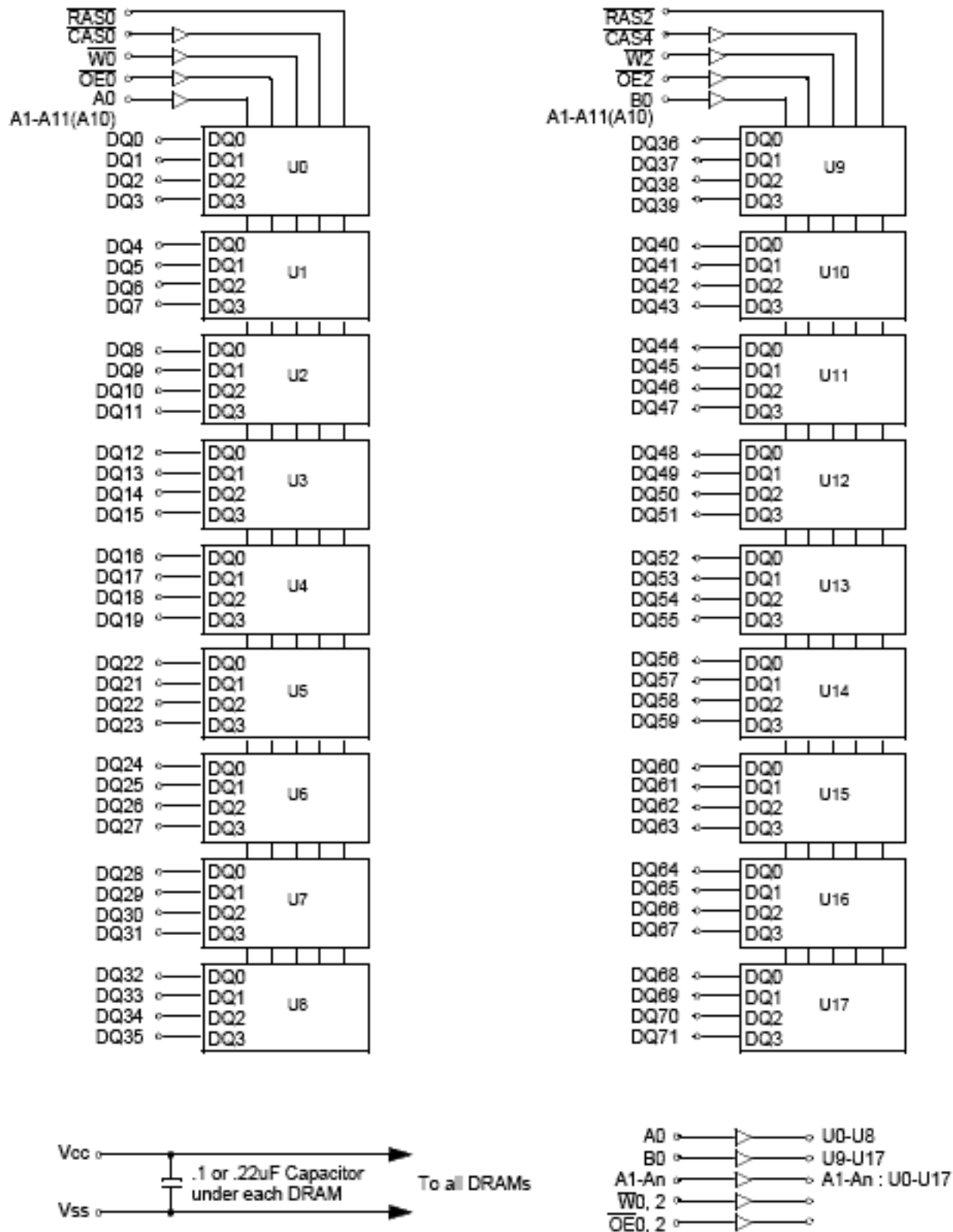

DRAM MODULE

ABSOLUTE MAXIMUM RATINGS *

Item	Symbol	Rating	Unit
Voltage on any pin relative Vss	V _{IN} , V _{OUT}	-1 to +7.0	V
Voltage on Vcc supply relative to Vss	V _{CC}	-1 to +7.0	V
Storage Temperature	T _{stg}	-55 to +125	°C
Power Dissipation	PD	18	W
Short Circuit Output Current	I _{OS}	50	mA

* Permanent device damage may occur if ABSOLUTE MAXIMUM RATINGS are exceeded. Functional operation should be restricted to the conditions as detailed in the operational sections of this data sheet. Exposure to absolute maximum rating conditions for intended periods may affect device reliability.

RECOMMENDED OPERATING CONDITIONS (Voltage referenced to V_{SS}, T_A = 0 to 70°C)

Item	Symbol	Min	Typ	Max	Unit
Supply Voltage	V _{CC}	4.5	5.0	5.5	V
Ground	V _{SS}	0	0	0	V
Input High Voltage	V _{IH}	2.4	-	V _{CC} +1* ¹	V
Input Low Voltage	V _{IL}	-1.0* ²	-	0.8	V

*1 : V_{CC}+2.0V/20ns, Pulse width is measured at V_{CC}.

*2 : -2.0V/20ns, Pulse width is measured at V_{SS}.

DC AND OPERATING CHARACTERISTICS (Recommended operating conditions unless otherwise noted)

Symbol	Speed	KMM372C400CK/CS		KMM372C410CK/CS		Unit
		Min	Max	Min	Max	
I _{CC1}	-5	-	1620	-	1980	mA
	-6	-	1440	-	1800	mA
I _{CC2}	Don't care	-	100	-	100	mA
I _{CC3}	-5	-	1620	-	1980	mA
	-6	-	1440	-	1800	mA
I _{CC4}	-5	-	1440	-	1620	mA
	-6	-	1260	-	1440	mA
I _{CC5}	Don't care	-	30	-	30	mA
I _{CC6}	-5	-	1620	-	1980	mA
	-6	-	1440	-	1800	mA
I _{I(L)}	Don't care	-45	45	-45	45	uA
I _{O(L)}	Don't care	-5	5	-5	5	uA
V _{OH}	Don't care	2.4	-	2.4	-	V
V _{OL}	Don't care	-	0.4	-	0.4	V

I_{CC1}* : Operating Current * (\overline{RAS} , \overline{CAS} , Address cycling @trc=min)

I_{CC2} : Standby Current ($\overline{RAS}=\overline{CAS}=\overline{W}=V_{IH}$)

I_{CC3}* : \overline{RAS} Only Refresh Current * ($\overline{CAS}=V_{IH}$, \overline{RAS} cycling @trc=min)

I_{CC4}* : Fast Page Mode Current * ($\overline{RAS}=V_{IL}$, \overline{CAS} cycling : tPC=min)

I_{CC5} : Standby Current ($\overline{RAS}=\overline{CAS}=\overline{W}=V_{CC}-0.2V$)

I_{CC6}* : \overline{CAS} -Before- \overline{RAS} Refresh Current * (\overline{RAS} and \overline{CAS} cycling @trc=min)

I_{I(L)} : Input Leakage Current (Any input 0≤V_{IN}≤V_{CC}+0.5V, all other pins not under test=0 V)

I_{O(L)} : Output Leakage Current(Data Out is disabled, 0V≤V_{OUT}≤V_{CC})

V_{OH} : Output High Voltage Level (I_{OH} = -5mA)

V_{OL} : Output Low Voltage Level (I_{OL} = 4.2mA)

* **NOTE** : I_{CC1}, I_{CC3}, I_{CC4} and I_{CC6} are dependent on output loading and cycle rates. Specified values are obtained with the output open. I_{CC} is specified as an average current. In I_{CC1} and I_{CC3}, address can be changed maximum once while $\overline{RAS}=V_{IL}$. In I_{CC4}, address can be changed maximum once within one page mode cycle, tPC.

DRAM MODULE

CAPACITANCE (TA = 25°C, Vcc=5V, f = 1MHz)

Item	Symbol	Min	Max	Unit
Input capacitance[A0-A11(A10), B0]	CIN1	-	20	pF
Input capacitance[$\overline{W0}$, $\overline{W2}$, $\overline{OE0}$, $\overline{OE2}$]	CIN2	-	20	pF
Input capacitance[$\overline{RAS0}$, $\overline{RAS2}$]	CIN3	-	80	pF
Input capacitance[$\overline{CAS0}$, $\overline{CAS4}$]	CIN4	-	20	pF
Input/Output capacitance[$\overline{DQ0}$ - 71]	CDQ1	-	20	pF

AC CHARACTERISTICS (0°C≤TA≤70°C, Vcc=5.0V±10%. See notes 1,2.)

Test condition : Vih/Vil=2.4/0.8V, Voh/Vol=2.4/0.4V, Output loading CL=100pF

Parameter	Symbol	-5		-6		Unit	Note
		Min	Max	Min	Max		
Random read or write cycle time	tRC	90		110		ns	
Read-modify-write cycle time	tRWC	133		155		ns	
Access time from \overline{RAS}	tRAC		50		60	ns	3,4
Access time from \overline{CAS}	tCAC		18		20	ns	3,4,5,11
Access time from column address	tAA		30		35	ns	3,10,11
\overline{CAS} to output in Low-Z	tCLZ	5		5		ns	3,11
Output buffer turn-off delay	tOFF	5	18	5	20	ns	6,11
Transition time(rise and fall)	tT	2	50	2	50	ns	2
\overline{RAS} precharge time	tRP	30		40		ns	
\overline{RAS} pulse width	tRAS	50	10K	60	10K	ns	
\overline{RAS} hold time	tRSH	18		20		ns	11
\overline{CAS} hold time	tCSH	48		58		ns	11
\overline{CAS} pulse width	tCAS	13	10K	15	10K	ns	
\overline{RAS} to \overline{CAS} delay time	tRCD	18	32	18	40	ns	4,11
\overline{RAS} to column address delay time	tRAD	13	20	13	25	ns	10,11
\overline{CAS} to \overline{RAS} precharge time	tCRP	10		10		ns	11
Row address set-up time	tASR	5		5		ns	11
Row address hold time	tRAH	8		8		ns	11
Column address set-up time	tASC	0		0		ns	
Column address hold time	tCAH	10		10		ns	
Column address to \overline{RAS} lead time	tRAL	30		35		ns	11
Read command set-up time	tRCS	0		0		ns	
Read command hold referenced to \overline{CAS}	tRCH	0		0		ns	8
Read command hold referenced to \overline{RAS}	tRRH	-2		-2		ns	8,11
Write command hold time	tWCH	10		10		ns	
Write command pulse width	tWP	10		10		ns	
Write command to \overline{RAS} lead time	tRWL	18		20		ns	11
Write command to \overline{CAS} lead time	tCWL	13		15		ns	
Data set-up time	tDS	-2		-2		ns	9,11
Data hold time	tDH	15		20		ns	9,11
Refresh period (4K refresh)	tREF		64		64	ms	
Refresh period (2K refresh)	tREF		32		32	ms	
Write command set-up time	tWCS	0		0		ns	7
\overline{CAS} to \overline{W} dealy time	tCWD	36		40		ns	7
Column address to \overline{W} delay time	tAWD	48		55		ns	7

DRAM MODULE

KMM372C400CK/CS
KMM372C410CK/CS

AC CHARACTERISTICS (0°C ≤ T_A ≤ 70°C, V_{CC} = 5.0V ± 10%. See notes 1,2.)

Test condition : V_{ih}/V_{il} = 2.4/0.8V, V_{oh}/V_{ol} = 2.4/0.4V, Output loading CL = 100pF

Parameter	Symbol	-5		-6		Unit	Note
		Min	Max	Min	Max		
$\overline{\text{CAS}}$ precharge to $\overline{\text{W}}$ delay time	tCPWD	53		60		ns	7
$\overline{\text{RAS}}$ to $\overline{\text{W}}$ delay time	tRWD	71		83		ns	7,11
$\overline{\text{CAS}}$ setup time($\overline{\text{CAS}}$ -before- $\overline{\text{RAS}}$ refresh)	tCSR	10		10		ns	11
$\overline{\text{CAS}}$ hold time($\overline{\text{CAS}}$ -before- $\overline{\text{RAS}}$ refresh)	tCHR	8		8		ns	11
$\overline{\text{RAS}}$ precharge to $\overline{\text{CAS}}$ hold time	tRPC	3		3		ns	11
Access time from $\overline{\text{CAS}}$ precharge	tCPA		35		40	ns	3,11
Fast page mode cycle time	tPC	35		40		ns	
Fast page mode read-modify-write cycle time	tPRWC	75		80		ns	
$\overline{\text{CAS}}$ precharge time(Fast page cycle)	tCP	10		10		ns	
$\overline{\text{RAS}}$ pulse width (Fast page cycle)	tRASP	50	200K	60	200K	ns	
$\overline{\text{RAS}}$ hold time from $\overline{\text{CAS}}$ precharge	tRHCP	35		40		ns	11
$\overline{\text{W}}$ to $\overline{\text{RAS}}$ precharge time ($\overline{\text{C}}$ -B- $\overline{\text{R}}$ refresh)	tWRP	15		15		ns	11
$\overline{\text{W}}$ to $\overline{\text{RAS}}$ hold time ($\overline{\text{C}}$ -B- $\overline{\text{R}}$ refresh)	tWRH	8		8		ns	11
$\overline{\text{CAS}}$ precharge(C-B-R counter test)	tCPT	20		20		ns	
$\overline{\text{OE}}$ access time	tOEA		18		20	ns	11
$\overline{\text{OE}}$ to data delay	tOED	18		20		ns	11
Output buffer turn off delay time from $\overline{\text{OE}}$	tOEZ	5		5	20	ns	11
$\overline{\text{OE}}$ command hold time	tOEH	13		15		ns	
Present Detect Read Cycle							
$\overline{\text{PDE}}$ to Valid PD bit	tPD		10		10	ns	
$\overline{\text{PDE}}$ to PD bit Inactive	tPDOFF	2	7	2	7	ns	



ELECTRONICS

NOTES

1. An initial pause of 200us is required after power-up followed by any 8 $\overline{\text{RAS}}$ -only or $\overline{\text{CAS}}$ -before- $\overline{\text{RAS}}$ refresh cycles before proper device operation is achieved.
2. Input voltage levels are V_{ih}/V_{il} . $V_{ih}(\text{min})$ and $V_{il}(\text{max})$ are reference levels for measuring timing of input signals. Transition times are measured between $V_{ih}(\text{min})$ and $V_{il}(\text{max})$ and are assumed to be 5ns for all inputs.
3. Measured with a load equivalent to 2TTL loads and 100pF.
4. Operation within the $t_{\text{RCD}}(\text{max})$ limit insures that $t_{\text{RAC}}(\text{max})$ can be met. $t_{\text{RCD}}(\text{max})$ is specified as a reference point only. If t_{RCD} is greater than the specified $t_{\text{RCD}}(\text{max})$ limit, then access time is controlled exclusively by t_{CAC} .
5. Assumes that $t_{\text{RCD}} \geq t_{\text{RCD}}(\text{max})$.
6. This parameter defines the time at which the output achieves the open circuit condition and is not referenced to V_{OH} or V_{OL} .
7. t_{WCS} is not restrictive operating parameter. It included in the data sheet as electrical characteristic only. If $t_{\text{WCS}} \geq t_{\text{WCS}}(\text{min})$ the cycle is an early write cycle and the data out pin will remain high impedance for the duration of the cycle.
8. Either t_{RCH} or t_{RRH} must be satisfied for a read cycle.
9. These parameters are referenced to the $\overline{\text{CAS}}$ leading edge in early write cycles.
10. Operation within the $t_{\text{RAD}}(\text{max})$ limit insures that $t_{\text{RAC}}(\text{max})$ can be met. $t_{\text{RAD}}(\text{max})$ is specified as reference point only. If t_{RAD} is greater than the specified $t_{\text{RAD}}(\text{max})$ limit, then access time is controlled by t_{AA} .
11. The timing skew from the DRAM to the DIMM resulted from the addition of buffers.

WRITE CYCLE (EARLY WRITE)

NOTE : DOUT = OPEN

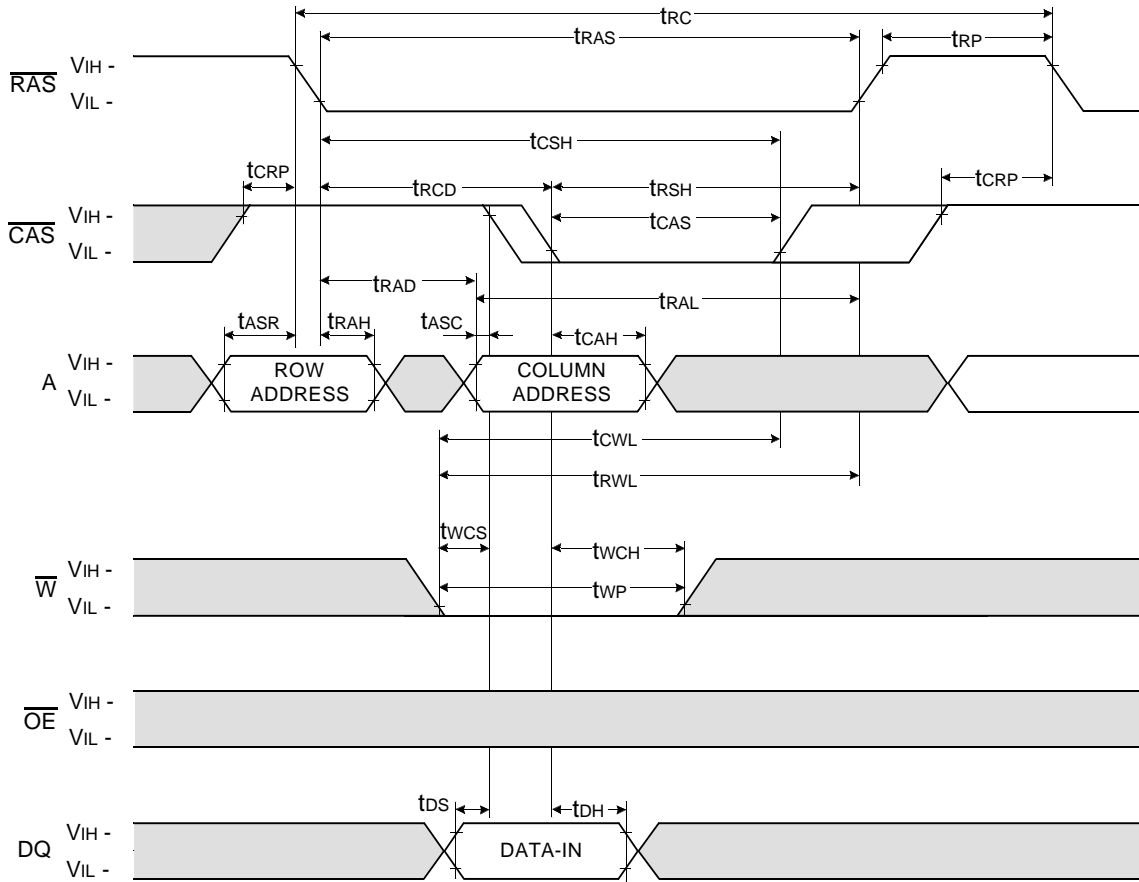

□ Don't care
■ Undefined

WRITE CYCLE (\overline{OE} CONTROLLED WRITE)

NOTE : DOUT = OPEN

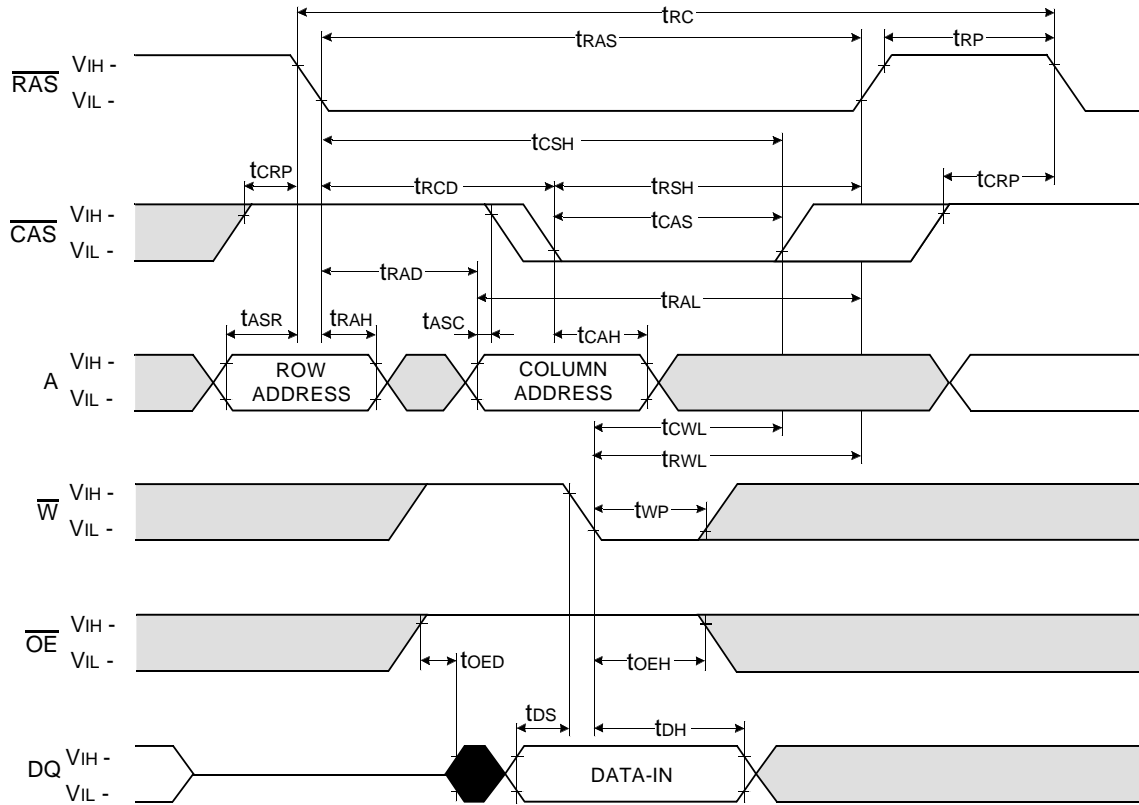

□ Don't care
■ Undefined

READ - MODIFY - WRITE CYCLE

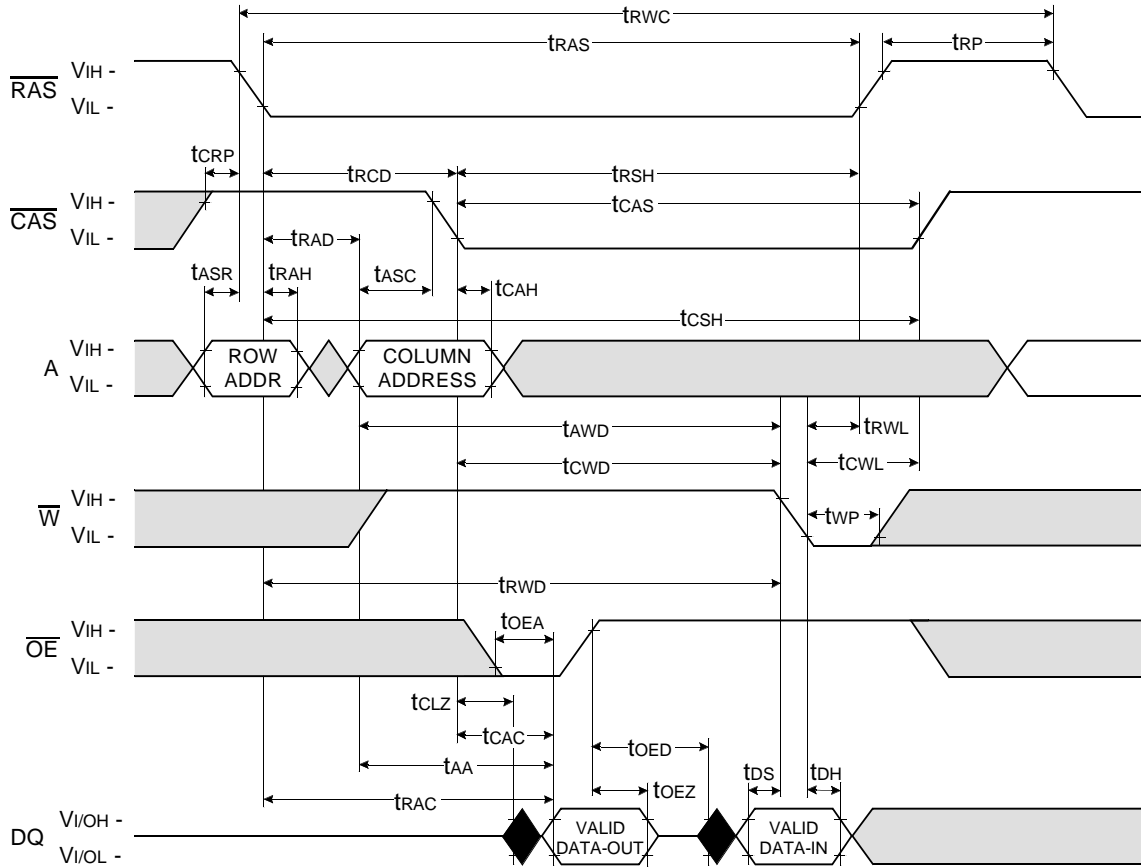

□ Don't care
■ Undefined

FAST PAGE READ CYCLE

NOTE : DOUT = OPEN

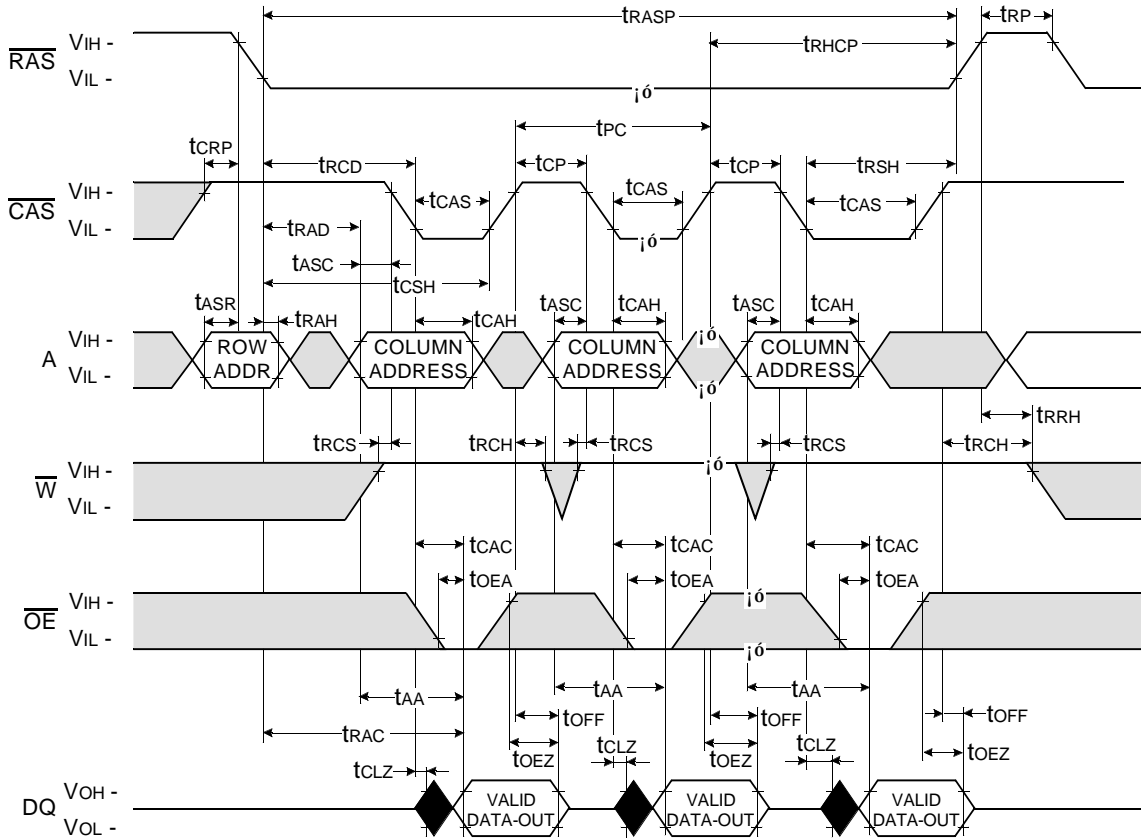

□ Don't care
■ Undefined

FAST PAGE WRITE CYCLE (EARLY WRITE)

NOTE : DOUT = OPEN

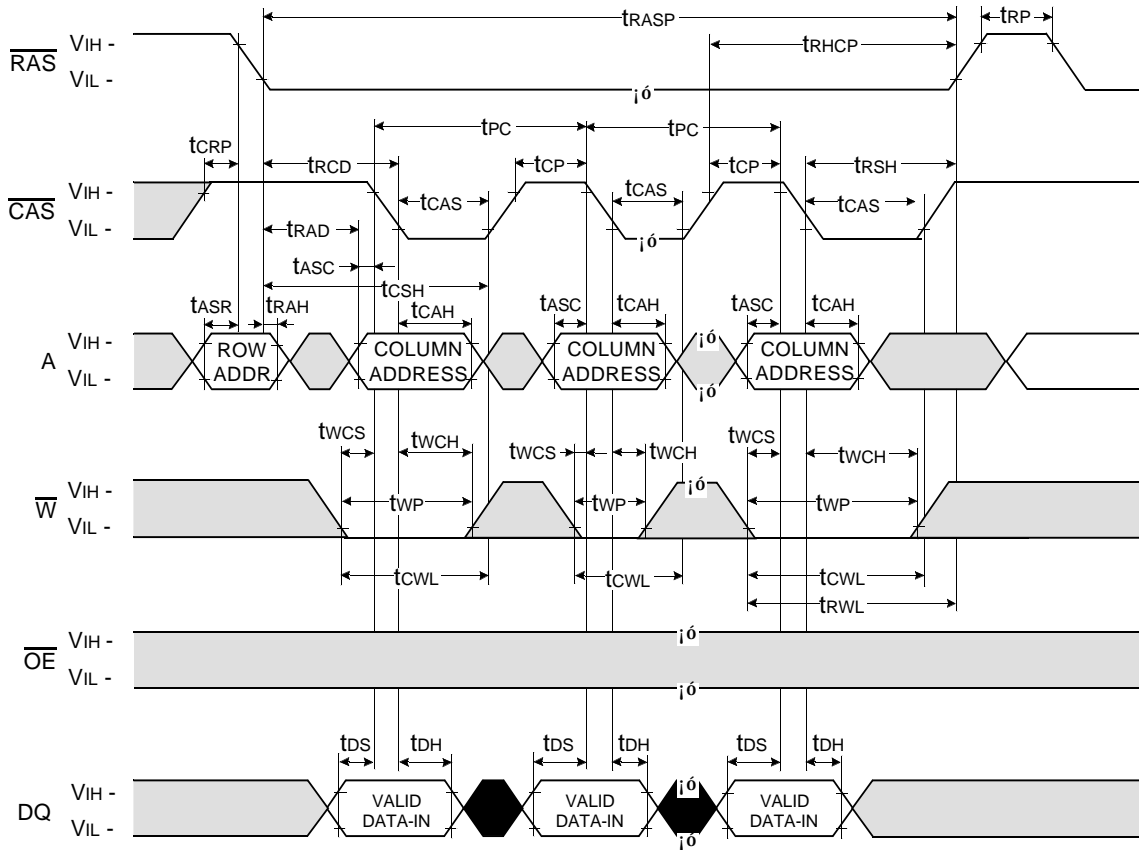

Don't care
 Undefined

FAST PAGE READ - MODIFY - WRITE CYCLE

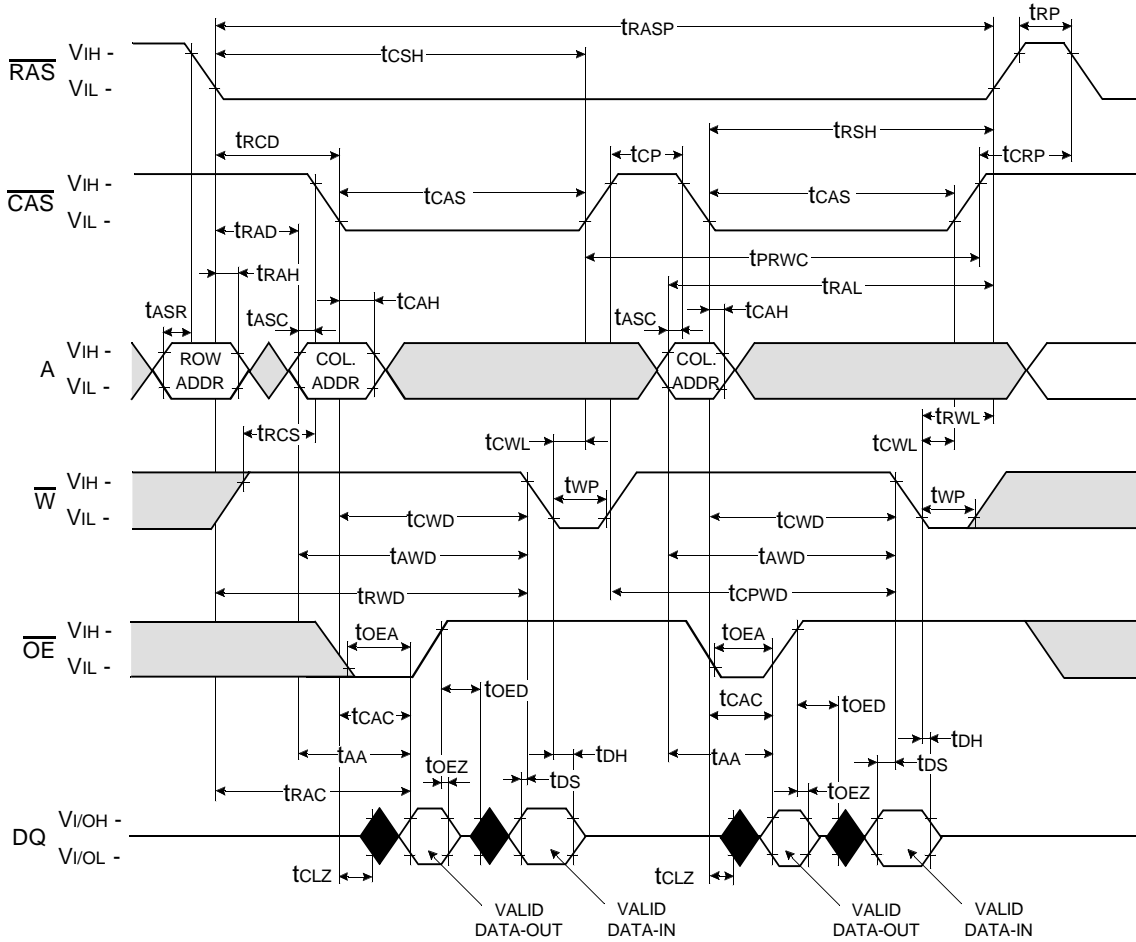

Don't care
 Undefined

DRAM MODULE

$\overline{\text{RAS}}$ - ONLY REFRESH CYCLE

NOTE : $\overline{\text{W}}$, $\overline{\text{OE}}$, DIN = Don't care

DOUT = OPEN

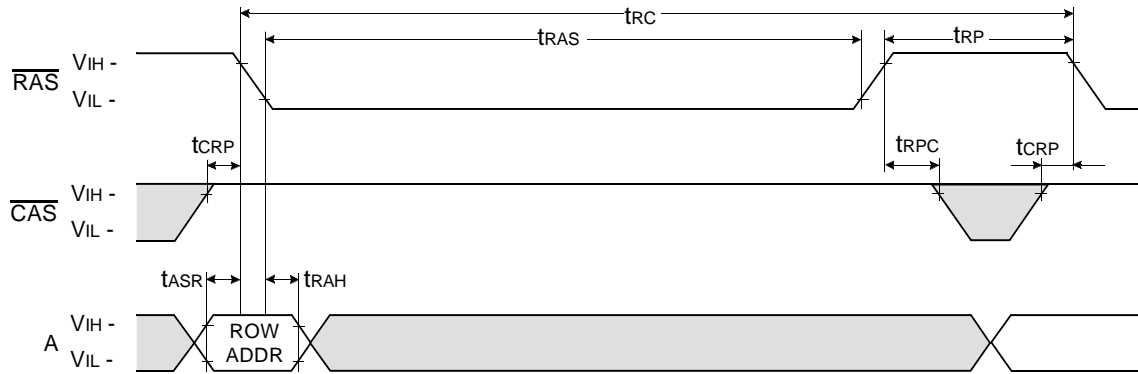

$\overline{\text{CAS}}$ - BEFORE - $\overline{\text{RAS}}$ REFRESH CYCLE

NOTE : $\overline{\text{OE}}$, A = Don't care

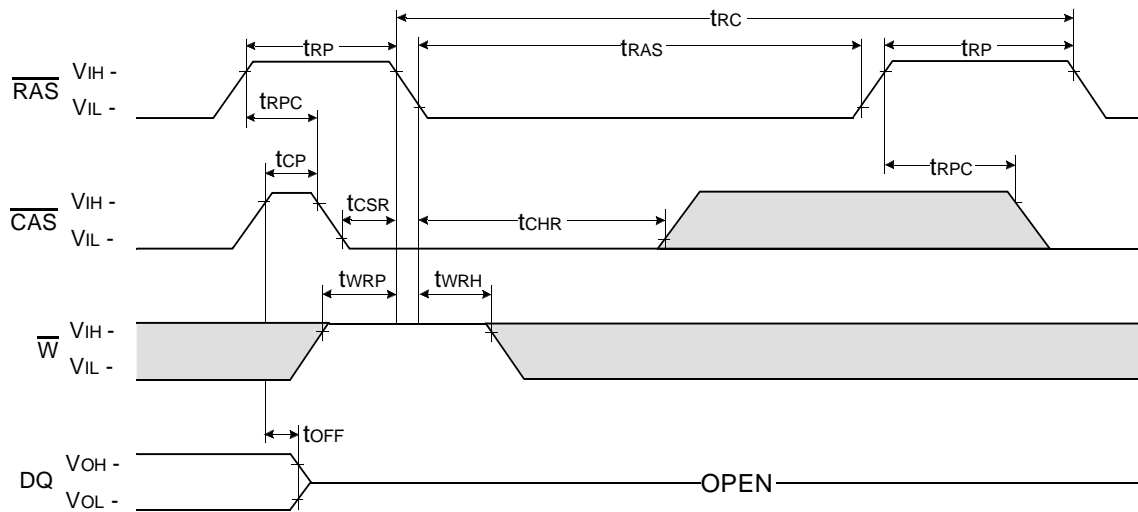

□ Don't care
■ Undefined

HIDDEN REFRESH CYCLE (READ)

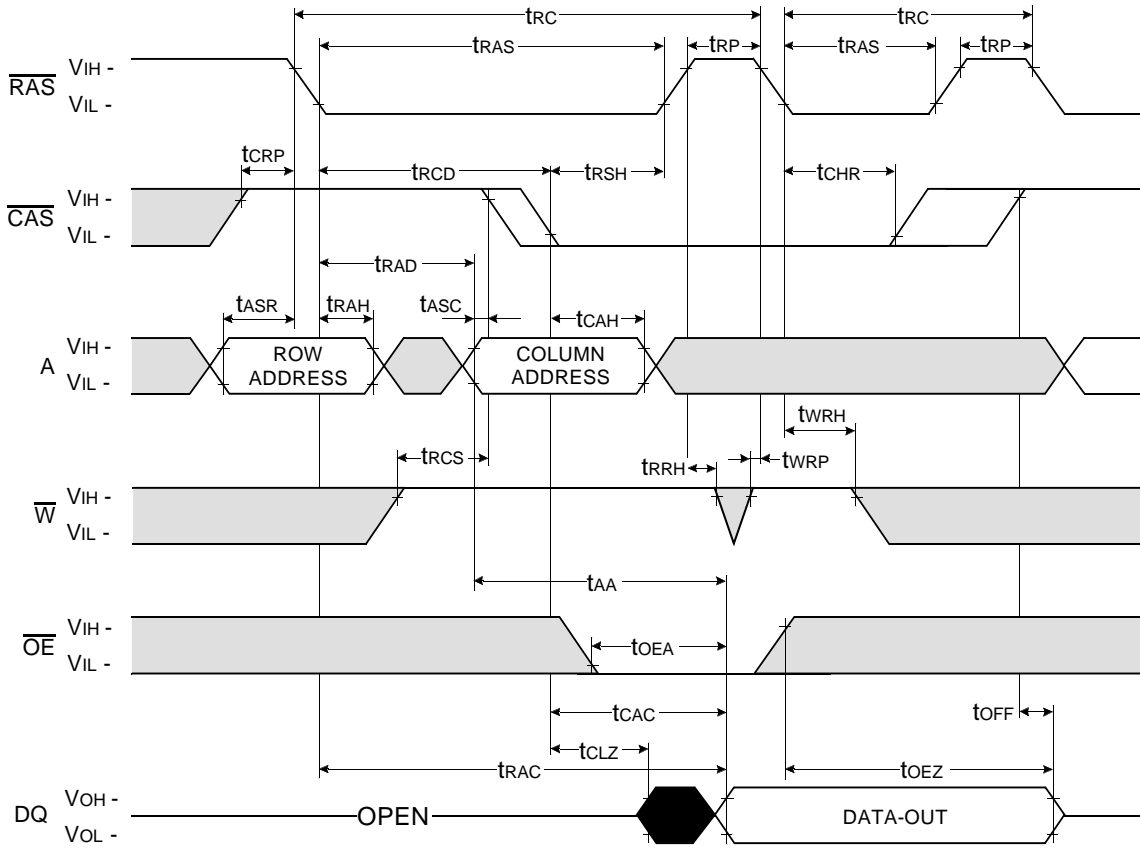

Don't care
Undefined

HIDDEN REFRESH CYCLE (WRITE)

NOTE : DOUT = OPEN

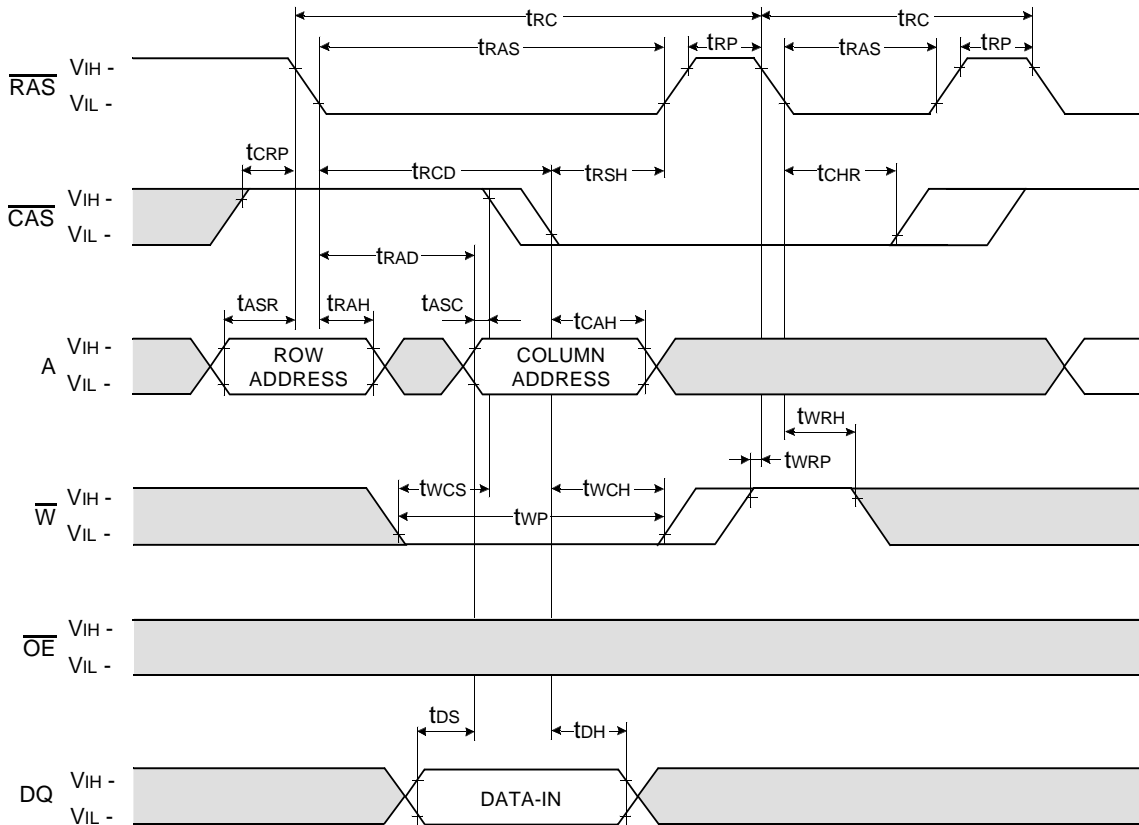

□ Don't care
■ Undefined

CAS - BEFORE - RAS SELF REFRESH CYCLE

NOTE : \overline{OE} , A = Don't care

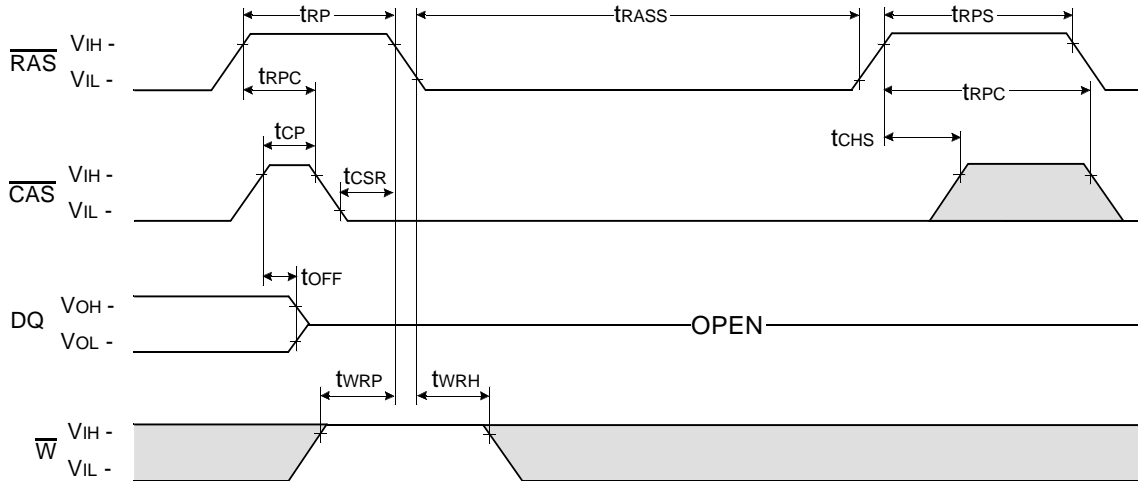

TEST MODE IN CYCLE

NOTE : \overline{OE} , A = Don't care

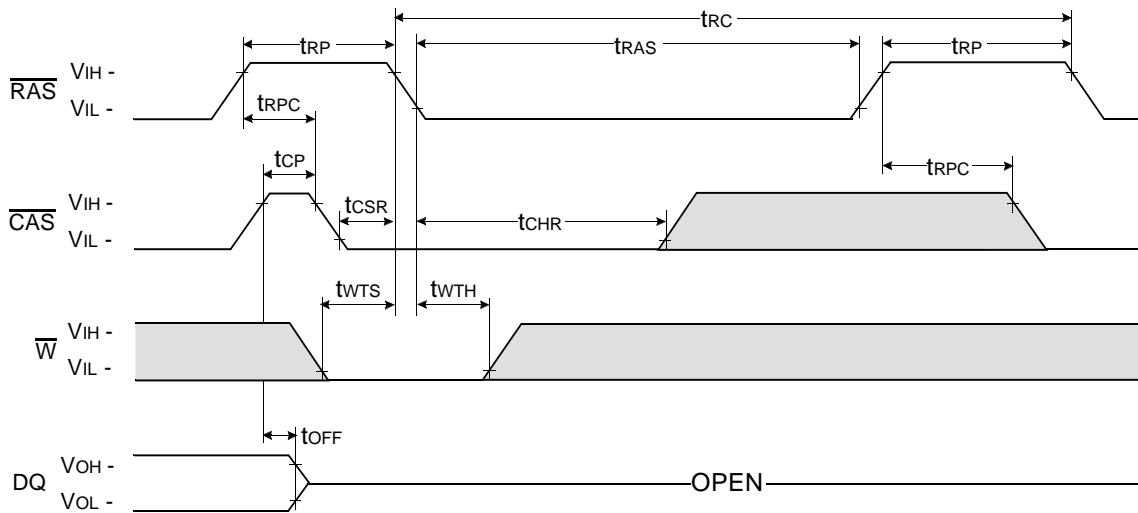

□ Don't care
■ Undefined

