

717-5210 to
717-5516

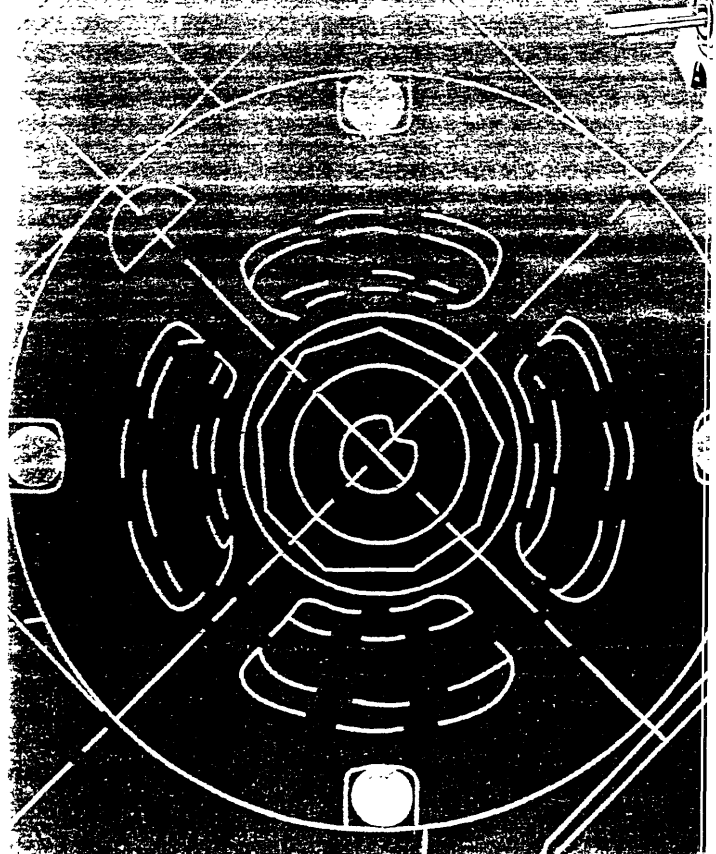

*Matchless motors
to match
your every need.*

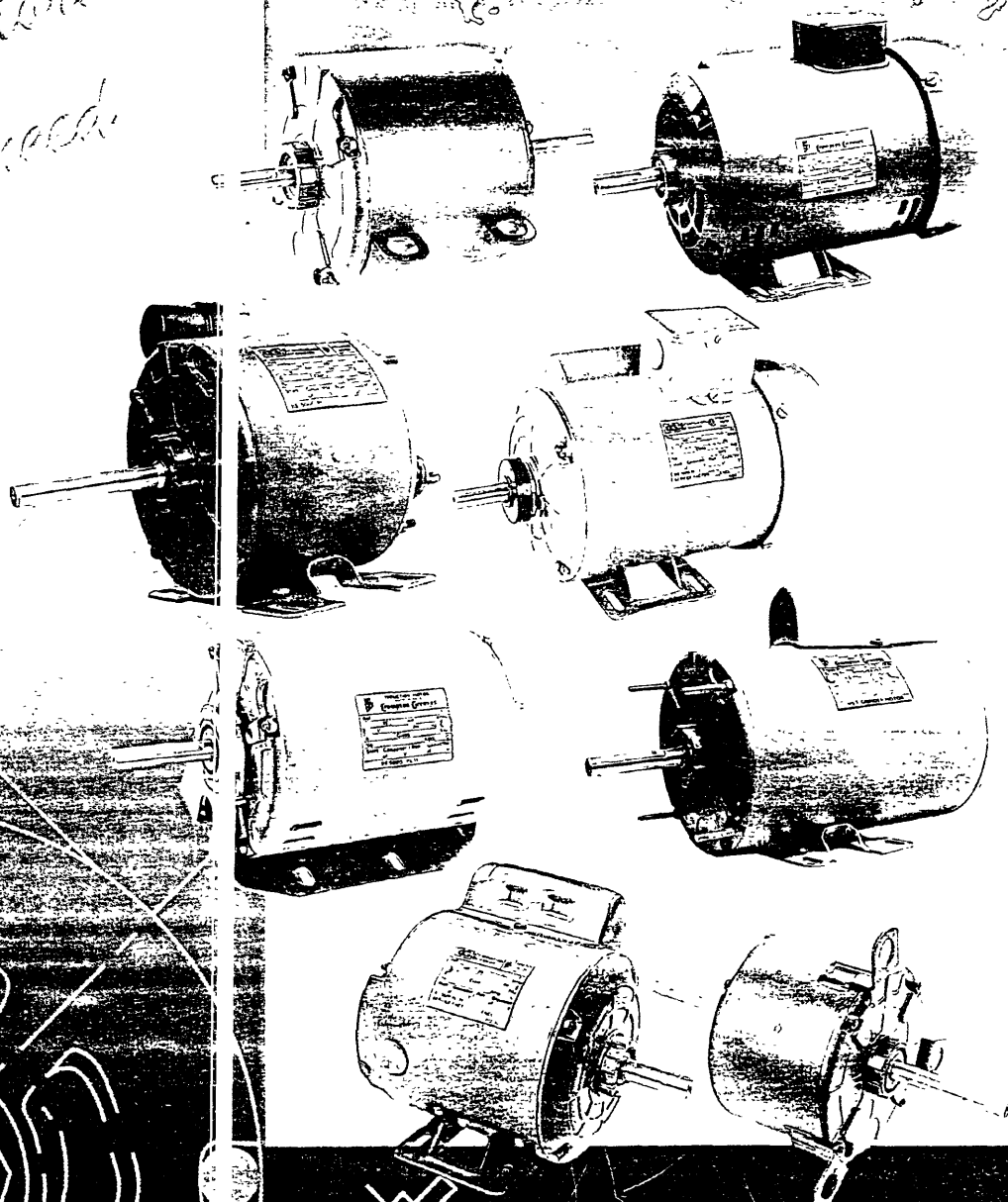

CG Crompton Greaves

CONTENTS	PAGE NO.
GENERAL DESCRIPTION	2
GENERAL PURPOSE FHP MOTORS	6
SPECIFICATIONS	6
STANDARD RANGE	6
EXTRA FEATURES	6
PERFORMANCE	6
SHIPPING SPECIFICATIONS	8
SPECIAL FHP MOTORS	11
MOTORS FOR 60 HZ SUPPLY	11
SPECIAL APPLICATION MOTORS	11
DIMENSIONS	12
FHP MOTOR SELECTION	17

GENERAL DESCRIPTION

The design and construction of this range of motors is essentially that of the basic induction motor, but with refinements introduced to meet specific market requirements.

Due to the need to be light weight for applications mainly in domestic/light industrial equipment, they are of rolled steel shell construction, with die-cast aluminium endshields. This form of construction also lends itself to economic production in the large numbers, required for these types of motor.

Popular ranges cover 2, 4, 6 and 8 pole speeds, suitable for single or three phase electrical supplies with outputs up to 2250W. Motor enclosure options are: protected drip-proof, drip-proof fan cooled, totally-enclosed and totally-enclosed fan-cooled. These are available with a choice of mountings: rigid base or solid foot, bolt on feet, resilient base, flange, tapped pad etc; also with ball or sleeve bearing options.

RANGE

Crompton Greaves offer the widest range of FHP Motors for an amazing variety of applications in the domestic and Industrial fields.

Crompton Greaves FHP motors are meticulously engineered and manufactured at 2 exclusive FHP motor factories equipped with state-of-the-art machinery. The motors have acquired an unmatched reputation for dependability in the market place.

Outputs extend from 50 W (1/16 HP) to 2250W (3HP) in single phase and upto 1500W (2HP) in three phase designs.

High emphasis on Application Engineering ensures excellent pre-order technical service to customers. Crompton Greaves have developed more than 4000 varieties of FHP motors. Chances are that the special motor required for a new application is already available in the Crompton Greaves range. If not, we will gladly make it for you.

STANDARDS

These motors conform to BS 5000 Part 11 for performance.

Dimensionally, motors in Frame 56 and 48 conform to BS 2048 Part I, while Frame 100S conforms to IEC. Motors in Frame 56 and 48 can also be offered to NEMA standards.

Flange motors can be offered with type C or B Flanges as specified.

RATING

All standard motors are continuously rated to comply with performance standards. Special motors for cyclic or short time duties, however, can be offered against specific applications

ENCLOSURES

The various types of enclosures are as follows:

Drip Proof (DP) to IP23

Drip Proof Fan Cooled (DPFC) to IP23

Totally Enclosed (TE) to IP44

Totally Enclosed Fan Cooled (TEFC) to IP44

Air-Over-Motor (AOM) in DP and TE variations.

Flame Proof

MOUNTINGS

The various types of mountings offered are as under:

Rigid Base (Solid Foot)

Flange type C, type B and special.

Foot on Flange

Resilient Base

Resilient Ring

Stator Pad

Endshield Pad

Through Stud

Special Mounting to customers' specifications

SINGLE PHASE MOTORS

By the nature of the market for FHP Motors, the main demand is for single phase types. The most common of these are Split Phase, Capacitor Start Induction Run, Capacitor Start and Run, Capacitor Start Capacitor Run, and Shaded Pole.

In order to be self-starting, an electric motor must have a rotating field. The phase displacement in a 3-phase supply produces this, but a single phase motor requires an auxiliary (starting) winding designed to give a displacement similar to a 2-phase supply before the effect is produced. It can be achieved in various ways, each of which has produced a motor with particular characteristics as follows.

Split Phase Start, Induction Run (Series : SS)

The starting winding uses fine wire and thus has a higher resistance. It is also arranged to have a low reactance. The current in the start winding thus leads that in the main winding and a rotating field is set up similar to a 2-phase motor. The start winding works at a high current density and it must be switched out as soon as possible when the machine reaches about 75% speed. These motors are suitable for low inertia loads and infrequent starting. Starting current is relatively large and account should be taken of this, when installing, to avoid excessive voltage drop

GENERAL DESCRIPTION

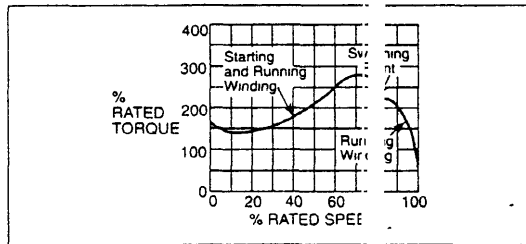
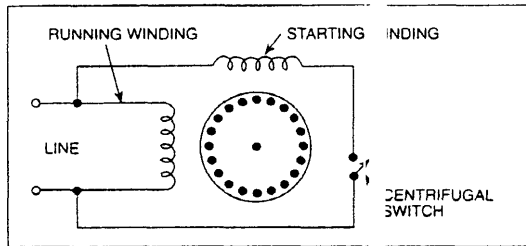

Capacitor Start and Run (Series : PSC)

Capacitor run motors use a capacitor, permanently connected in series with one of the stator windings, to achieve a compromise between good starting torque and good running characteristics. This design is lower in cost than other capacitor motors that incorporate capacitor switching systems. It achieves better running characteristics than a split phase motor. Capacitor run motors are also called Permanent Split Capacitor (PSC) motors.

The Standard range covers Pump Duty PSC Motors, however, special application motors can be offered.

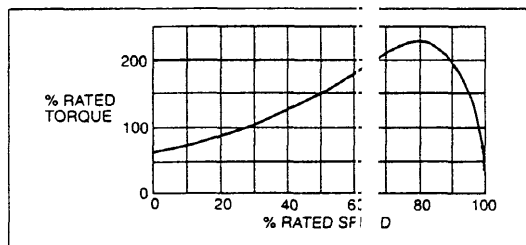
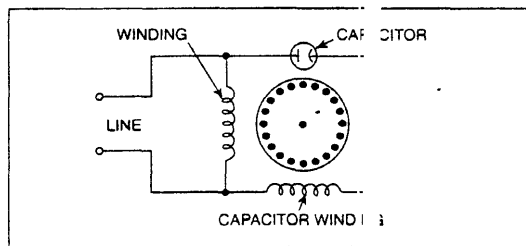

Capacitor Start, Induction Run (Series : CS)

A capacitor is inserted in series with the start winding to reduce the inductive reactance to a low or even negative value. The start winding current therefore leads the main windings current by almost 90°. A large electrolytic capacitor is used and, since this is short time rated, it must be switched out as soon as the motor has run up to about 75% speed. These

motors are suitable for loads of higher inertia or more frequent starting than with the Split Phase Motors. Starting torque is improved and starting current reduced.

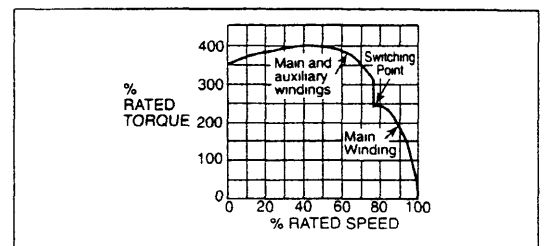
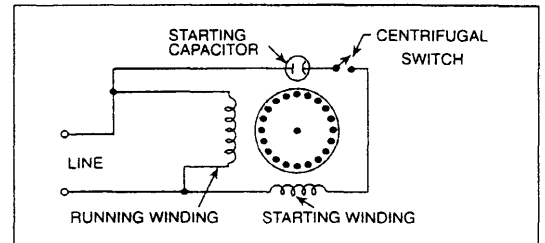

Capacitor Start, Capacitor Run (Series : CSCR)

A large electrolytic capacitor is used for starting but this is switched out when the machine runs up to speed and a smaller paper capacitor is left in circuit while the machine continues to operate. Thus the good starting performance of the capacitor start motor is combined with the good running performance of the capacitor start and run motor.

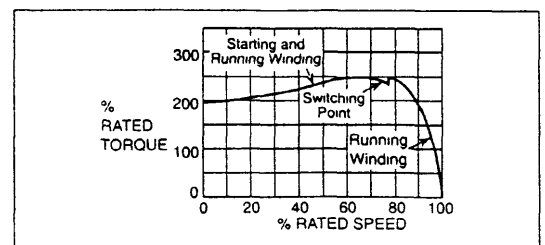
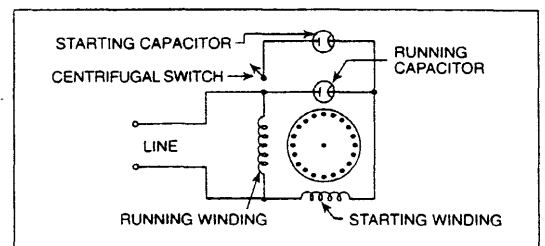

Shaded Pole

A short circuited copper ring is placed round a portion of each pole and the ring has currents induced in it by transformer action- these cause the flux in the shaded portion to lag the flux in the main pole so a rotating field is set up. Starting torque is low and efficiency is poor since losses occur continuously in the shading ring which cannot be switched out

GENERAL DESCRIPTION

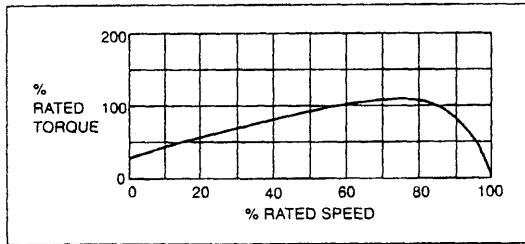
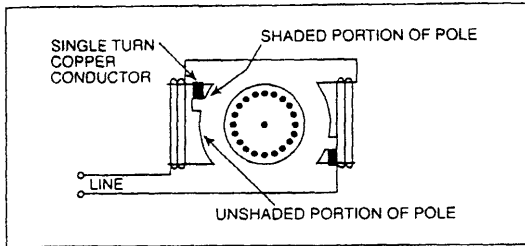

BEARINGS

All angle sleeve bearing motors are packed with wool felt that holds the oil and saves loss by leakage. Oil is wick-fed into an exclusive recirculatory system which ensures complete and continuous lubrication of all bearing and thrust surfaces.

A new, highly effective "PERMAWICK" lubrication system is being introduced in place of above arrangement.

Motors with ball bearings employs double shielded / sealed bearings greased for life, cutting out the need for frequent lubrication.

The bearing housings are fine bored to precision dimensions on precision boring machines. The shafts have excellent surface finish closely ground on the most advanced grinding machines. This ensures close tolerances and a high degree of concentricity leading to correct bearing fits for extended bearing life.

TERMINAL ARRANGEMENT

Terminals are housed in Terminal Boxes suitable for conduit or for open wiring, if preferred. Motor cables are colour coded to BS standards and terminals are marked for identification and reconnection. A terminal diagram is attached to each motor for convenience.

ROTATION

The single phase, FHP motors are supplied, as standard, connected for clockwise rotation viewed from the driving end, unless specified otherwise. Reversal of the starting winding leads at the motor terminal board, will reverse rotation of all types, except shaded pole, which cannot be reversed after manufacture.

Sometimes capacitor-start-and-run models can be 'balance wound' to facilitate instantaneous reversal with appropriate switching.

OPEN CIRCUITING DEVICES

Split phase and all capacitor-start models must have some means of switching the starting circuit out of circuit once the motor has accelerated up to speed.

The centrifugal switch is by far, the most popular device and a standard fitting on respective Crompton Greaves motors. As the name implies this is a speed sensitive device, whereby a switch is opened by the centrifugal action of weighted flyers, generally operating at 75-80% full-load speed.

Alternatively, a current relay is sometimes adopted, the operating coil being connected in series with the run winding and actuated as the current falls during the acceleration period, thus switching out the starting circuit.

Occasionally the centrifugal switch is adopted solely as a speed sensitive device for operation of external circuits.

CAPACITORS

These are electrolytic short-time rated capacitors used on capacitor - start models, usually mounted on the motor frame. Special considerations required if there are extremes in ambient temperature.

Electrolytic capacitors might deteriorate when stored without use for long periods. Hence they normally should be reactivated by switching the motor on and off.

EXTERNAL THERMATRIPS

This overload device is usually mounted in the motor endshield. It comprises a temperature sensitive, bimetal disc with a heater and snap-action switch contacts. It is connected in series with one of the main supply leads.

The 'trigger' temperature of the bimetal disc is thus a function of both the motor mains current, via the Thermatrip heater, and the interior temperature of the motor.

The snap action of the bimetal disc is caused by reversal of the disc curvature. The bimetal characteristics afford both automatic or manual reset. If manual reset is required, the normal resetting temperature of the bimetal disc is arranged below that of the normal

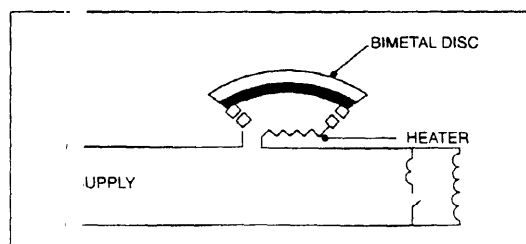

conditions. It will, therefore, only restart on manual resetting of the bimetal disc

GENERAL DESCRIPTION

The Thermatrips operates in the following critical overheating conditions:

a) Overload

Here the combination of the abnormally high supply current and rising winding temperature actuates the bimetal disc.

b) Locked Rotor

The abnormally high locked rotor supply current, through the Thermatrip heaters, actuates the bimetal disc much faster than if it were responding only to increasing winding temperature.

The characteristics of the bimetal disc are selected according to the particular requirements of each motor type. For example, to safeguard against the high starting current of a split phase motor the Thermatrip would be designed to operate within five seconds from cold.

For the more favourable starting current characteristics of the capacitor start motor, this period is increased to about twelve seconds.

Starting current characteristics of capacitor-start-and-run motors are ever more favourable, and because the capacitor is continuously rated and much less vulnerable, operating time for the Thermatrip can be increased up to several minutes.

Fitment of Thermatrips is designed to limit initial peak temperatures under stalled motor conditions as follows:

Insulation Class		B	F
Peak Temperature	2	150°C	240°C

Under prolonged stalled conditions with automatic resetting Thermatrips the peak and average temperatures after the first hour should not exceed:

Insulation Class		B	F
Peak Temperature	2	100°C	215°F
Average Temperature	1	75°C	190°C

Under overload conditions the following temperatures should not be exceeded:

Insulation Class		B	F
Peak Temperature		150°C	180°C

EMBEDDED THERMATRIPS

Small thermostat device, set to operate at 140 + 10°C and connected in series with the mains supply, are usually considered adequate protection on general purpose motors. These are inexpensive and auto-reset type.

IMPEDANCE PROTECTION

Some low-output motors have a sufficiently high winding impedance to render them impervious to dangerous overheating, even under locked-rotor conditions.

RELIABILITY

Each component goes through rigorous quality control at every stage of manufacture. With well-equipped material testing laboratories to back up the modern manufacturing process, the final product is a highly reliable motor.

In spite of this, each and every motor is subjected to a silence room test, dynamometer tests to check all torque levels, and 45 min. running-in with frequent start-stops to ensure trouble-free operation.

DUAL VOLTAGE

A 2:1 ratio, dual voltage (220/110 Volts) requirement in single phase motors is readily accommodated by a series/parallel connection of the windings. The relative capacitor values of 'capacitor' types is not, however, so easily catered for, because a 110 volt machine requires four times the capacitor value of that for the 220 volt connection. This is overcome by connecting the starting circuit (the start winding in series with the capacitor) to the centre point of the run winding in the higher voltage connection. Thus the voltage across the starting circuit is always that of the lower voltage irrespective of the supply connection.

APPLICATION ENGINEERING

Over the year Crompton Greaves engineers have accumulated a thorough knowledge of the various applications of FHP motors and have developed the widest range of motors to suit every need. In case any special motor is to be developed our application engineers will be glad to discuss details with customers.

GENERAL PURPOSE FHP MOTORS

SPECIFICATIONS

For 220/240V, 50Hz, single phase, AC supply, to BS 2048 Part I and BS 5000 Part II for Frame 56 and IEC for Frame 100S
 Horizontal Rigid Base Mounting
 Continuous Duty
 Class B insulated for up to 40°C ambient.
 Reversible by electrical connections.
 On-site fitment of Flange C possible.
 Ball Bearings for 100S Frame, option of Ball

Bearings or Sleeve Bearings for 56 Frame.
 RAF Blue Grey Colour.
 Terminal Box for BS thread conduit entry/ open wiring.
 Clockwise rotation when viewed from Driving End.
 Split Phase and Cap Start Motors are with Centrifugal Open Circuiting Gear.
 Carton Packing

STANDARD RANGE

FRAME	ENCLOSURE	POLE	SINGLE PHASE OUTPUTS (HP)				THREE PHASE OUTPUTS (HP)
			SPLIT PHASE (SS)	CAP START IND RUN (CS)	CAP START CSCR	CAP START & RUN (PSC)	
56	DP, DPFC TE (AOM), TEFC	2	-	1/4 - 1.5	1/2 - 2.0	1/2 - 1.5	1/4 - 1.5
		4	1/4 - 3/4	1/8 - 1.5	1.0	1/4 - 1.0	1/4 - 1.0
		6	1/8 - 1/3	1/8 - 1/3	-	1/4 - 1/3	1/6 - 1/3
		8	-	-	-	1/8 - 1/4	1/8 - 1/3
100S	DP, TEFC	4	-	1.5	5 - 3.0	-	1.5 - 2.0

EXTRA FEATURES

The following extra features are offered on request :

- Flange mounting on ball bearing motors
- Foot-cum Flange on ball bearing motors
- Resilient base mounting for DP motors
- Resilient ring mounting
- Stator pad mounting on Frame 56 motors
- End shield pad mounting on Frame 56 motors
- Extended bolt or stud mounting
- Single shaft extension upto 100 mm

- Double or tapered or screwed shaft extension upto 150 mm on DP motor
- Tapped hole on shaft
- Standard flat keyway on shaft
- Oil seal for flange motors
- Anti-corrosive treatment
- Loose lead wires upto 900 mm
- Accessible manual or auto-reset External Thermatrix fitted on endshield/terminal box alternatively auto-reset Embedded Thermatrix for PSC motor only.

PERFORMANCE DATA

Single Phase, 220/240 V, 50 Hz, 2 Pole, DP/TEFC Motors in Frame 56 and 100S.

HP	FRAME	ENCLOSURE	TYPE	RATE	FL WATTS	TORQUE % FLT		CAP MFD	I(ST) AMPS	EFF %	POWER FACTOR
				AMPS		STT	POT				
1/4	C52	DP/TEFC	CS	2.1	350	275	210	50	10	51	0.69
1/3	C54	DP/TEFC	CS	2.8	450	275	210	50	13	56	0.67
1/2	C54	DP/TEFC	CS	3.5	620	275	210	100	17	60	0.74
3/4	C56	DP/TEFC	CS	5.2	920	275	210	100	27	60	0.74
1.0	C58	DP/TEFC	CS	6.6	1125	275	210	120	32	67	0.71
1.5	C58	DP/TEFC	CSCR	7.0	1480	250	210	160+10	35	74	0.88
1.5	C58	DP	CS	8.0	1550	250	210	160	35	71	0.81
1.75	C59	DP/TEFC	CSCR	8.2	1800	250	210	160+10	38	72	0.91
2.0#	C59	TEFC	CSCR	8.5	1960	200	210	160+15	44	77	0.96

Pump Duty Motors

GENERAL PURPOSE FHP MOTORS

PERFORMANCE DATA (continued)

Single Phase, 220/240 V, 50 Hz, 4 Pole,
DP/TEFC Motors in Frame 56 and 100S.

HP	FRAME	ENCLOSURE	TYPE	RAT	D FL	TORQUE % FLT		CAP MFD	I(ST) AMPS	EFF %	POWER FACTOR
				AMPS		WATTS	STT				
1/4	C52	DP/TEFC	SS	2.5	360	210	210	-	20	50	0.60
	C52	DP/TEFC	CS	2.5	360	300	210	50	10	50	0.60
1/3	C54	DP/TEFC	SS	3.0	450	210	210	-	23	56	0.63
	C54	DP/TEFC	CS	3.0	450	300	210	50	13	56	0.63
1/2	C54	DP	SS	4.0	620	210	210	-	30	60	0.65
	C56	TEFC	SS	4.0	620	210	210	-	30	60	0.65
	C54	DP	CS	4.0	620	300	210	100	20	60	0.65
	C56	TEFC	CS	4.0	620	300	210	100	20	60	0.65
3/4	C56	DP	SS	5.9	890	210	210	-	44	62	0.63
	C58	TEFC	SS	5.9	890	210	210	-	44	62	0.63
	C56	DP	CS	5.6	880	275	210	120	25	63	0.65
	C58	TEFC	CS	5.6	880	275	210	120	25	63	0.65
1.0	C58	DP	CSCR	6.0	1040	275	210	120+10	37	72	0.72
	C58	TEFC	CSCR	6.0	1040	275	210	120+10	37	72	0.72
	C58	DPFC	CS	7.0	1125	275	210	120	37	67	0.65
1.5	Q104	TEFC	CSCR	8.8	1600	240	220	200+10	30	69	0.76
2.0	Q104	TEFC	CSCR	9.9	1860	240	220	200+15	53	81	0.78
3.0	Q105	TEFC	CSCR	13.5	3000	200	200	280+30	75	75	0.93

‡ Also offered in C50 Series

Single Phase, 220/240 V, 50 Hz, 6 Pole,
DP Motors in Frame 56.

HP	FRAME	ENCLOSURE	TYPE	RAT	D FL	TORQUE % FLT		CAP MFD	I(ST) AMPS	EFF %	POWER FACTOR
				AMPS		WATTS	STT				
1/4	C58	DP	CS	2.8	360	300	200	50	10	50	0.56
1/4	C58	DP	SS	2.8	360	175	200	-	18	50	0.56
1/3	C58	DP	CS	3.2	460	265	200	50	12	54	0.62
1/3	C58	DP	SS	3.2	460	180	200	-	23	54	0.62

Single Phase, 220/240 V, 50 Hz, 8 Pole,
DP Motors in Frame 56.

HP	FRAME	ENCLOSURE	TYPE	RAT	D FL	TORQUE % FLT		CAP MFD	I(ST) AMPS	EFF %	POWER FACTOR
				AMPS		WATTS	STT				
1/8	C56	DP	PSC	1.0	170	35	200	4	3.3	53	0.74
1/4	C58	DP	PSC	1.7	340	35	160	6.3	4.5	53	0.86

GENERAL PURPOSE FHP MOTORS

PERFORMANCE DATA (continued)

Three Phase, 415 V, 50 Hz, Star Connected,
4 Pole, DP/TEFC Motors in Frame 56.

HP	FRAME	ENCLOSURE	TYPE	RATED		TORQUE % FLT			CAP MFD	I(ST) AMPS	EFF %	POWER FACTOR
				AMPS	V	ATTS	STT	POT				
1/4	C52	DP/TEFC	3 Ø	0.7		320	250	250	-	3.3	56	0.64
1/3	C52	DP/TEFC	3 Ø	0.9		410	250	250	-	4.2	61	0.63
1/2	C54	DP/TEFC	3 Ø	1.2		530	250	250	-	6.5	70	0.61
3/4	C54	DP/TEFC	3 Ø	1.5		820	250	250	-	7.8	67	0.76
1.0	C56	DP/TEFC	3 Ø	1.9		980	250	250	-	10.5	77	0.72

Notes :

FLT - Full Load Torque
STT - Starting Torque
POT - Pull Out Torque
FL - Full Load

Start capacitor Voltage : 275 V
Run capacitor Voltage : 400 V

56 Frame : Ball Bearings
6203 at both (DE) and (ODE)
100 Frame : Ball Bearings
6205 at (DE) and 6203 (ODE)

CF Gear/OC Switch: Common for both Frames
Different CF Gear for 2 Pole, 4 Pole & 6 Pole motors.

SHIPPING SPECIFICATIONS

Single Phase, 220/240 V, 2 Pole, DP/TEFC Motors

HP	FRAME	ENCLOSURE	TYPE	NET WT. KG.	GROSS WT. KG.	CARTON SIZE IN MM			VOLUME CUBIC METRES
						L	W	H	
1/4	C52	DP	CS	7.5	9.5	330	255	246	0.021
	C52	TEFC	CS	8.5	10.5	410	265	286	0.031
1/3	C54	DP	CS	9.4	11.5	330	255	246	0.021
	C54	TEFC	CS	11.4	13.4	410	265	286	0.031
1/2	C54	DP	CS	9.6	11.5	330	255	246	0.021
	C54	TEFC	CS	11.6	13.6	410	265	286	0.031
3/4	C58	DP	CS	11.0	13.5	410	265	286	0.031
	C58	TEFC	CS	13.0	15.0	410	265	286	0.031
1.0	C58	DP	CS	15.0	17.0	420	295	286	0.035
	C58	TEFC	CS	14.0	16.0	420	295	286	0.035
1.5	C58	DP	CS	15.0	17.0	420	295	286	0.035
	C58	TEFC	CS	17.0	19.0	420	295	286	0.035
1.0	C58	TEFC	CSCR	16.2	18.2	420	295	286	0.035
1.5*	C58	DPFC	CSCR	15.5	17.5	420	295	286	0.035
1.75	C59	DP	CSCR	17.0	19.0	420	295	286	0.035
	C59	TEFC	CSCR	18.0	20.0	420	295	286	0.035
1.75*	C58	DPFC	CSCR	15.5	17.5	420	295	286	0.035
2.0*	C58	DPFC	CSCR	16.0	18.0	420	295	286	0.035
2.0#	C59	TEFC	CSCR	18.5	20.5	420	295	286	0.035
2.7*	C59	DPFC	CSCR	18.5	20.5	420	295	286	0.035

* Compressor Duty Motors, # Pump Duty Motors

GENERAL PURPOSE FHP MOTORS

SHIPPING SPECIFICATIONS (Continued)

Single Phase, 220/240 V, 4 Pole, DP/TEFC Motors

HP	FRAME	ENCLOSURE	TYPE	NET WT.	GROSS WT.	CARTON SIZE IN MM			VOLUME
				KG	KG	L	W	H	CUBIC METRES
1/4	C52	DP	SS	6.0	8.0	330	255	246	0.021
	C52	TEFC	SS	7.0	9.0	410	265	286	0.031
	C52	DP	CS	6.5	8.5	330	255	246	0.021
	C52	TEFC	CS	7.5	9.5	410	265	286	0.031
1/3	C54	DP	SS	8.0	10.0	330	255	246	0.021
	C54	TEFC	SS	9.0	11.0	410	265	286	0.031
	C54	DP	CS	8.5	10.5	330	255	246	0.021
	C54	TEFC	CS	9.5	11.5	410	265	286	0.031
1/2	C54	DP	SS	11.5	11.5	330	255	246	0.021
	C56	TEFC	SS	11.5	11.5	410	265	286	0.031
	C54	DP	CS	11.0	11.0	330	255	246	0.021
	C56	TEFC	CS	12.5	14.5	410	265	286	0.031
3/4	C56	DP	SS	12.0	12.0	330	255	246	0.021
	C58	TEFC	SS	13.5	13.5	410	265	286	0.031
	C56	DP	CS	12.5	12.5	330	255	246	0.021
	C58	TEFC	CS	14.0	14.0	420	295	286	0.035
1.0	C58	DP	CSCR	14.0	14.0	420	295	286	0.035
	C58	TEFC	CSCR	15.0	15.0	420	295	286	0.035
	C58	DPFC	CS	13.5	13.5	420	295	286	0.035
1.5	Q104	TEFC	CSCR	27.0	27.0	440	310	337	0.046
2.0	Q104	TEFC	CSCR	31.0	31.0	440	310	337	0.046
3.0	Q104	TEFC	CSCR	37.0	37.0	465	310	337	0.049

Single Phase, 220/240 V, 6 Pole, DP Motors

HP	FRAME	ENCLOSURE	TYPE	NET WT.	GROSS WT.	CARTON SIZE IN MM			VOLUME
				KG	KG	L	W	H	CUBIC METRES
1/4	C58	DP	CS	11.0	15.0	420	295	286	0.035
1/4	C58	DP	SS	11.0	14.0	420	295	286	0.035
1/3	C58	DP	CS	16.0	16.0	420	295	286	0.035
1/3	C58	DP	SS	15.0	15.0	420	295	286	0.035

Single Phase, 220/240 V, 8 Pole, DP Motors

HP	FRAME	ENCLOSURE	TYPE	NET WT.	GROSS WT.	CARTON SIZE IN MM			VOLUME
				KG	KG	L	W	H	CUBIC METRES
1/8	C58	DP	CR	13.0	13.0	420	295	286	0.035
1/4	C58	DP	SS	14.0	14.0	420	295	286	0.035

GENERAL PURPOSE FHP MOTORS

SHIPPING SPECIFICATIONS (Continued)

Three Phase, 415 V, Star Connected, 4 Pole,
DP/TEFC Motors

HP	FRAME	ENCLOSURE	TYPE	NETT WT.	GROSS WT.	CARTON SIZE IN MM			VOLUME
				KG.	KG	L	W	H	CUBIC METRES
1/4	B52	DP	3 Ø	6.0	8.5	330	265	246	0.021
	B52	TEFC	3 Ø	7.0	9.0	410	265	286	0.031
1/3	B52	DP	3 Ø	7.0	9.5	330	265	246	0.021
	B52	TEFC	3 Ø	8.0	10.5	410	265	286	0.031
1/2	B54	DP	3 Ø	7.5	9.5	330	265	246	0.021
	B54	TEFC	3 Ø	9.0	11.5	410	265	286	0.031
3/4	B54	DP	3 Ø	9.6	11.5	330	255	246	0.021
	B54	TEFC	3 Ø	10.5	12.5	410	265	286	0.031
1.0	B56	DP	3 Ø	11.0	13.5	330	265	246	0.021
	B56	TEFC	3 Ø	12.5	15.0	410	265	286	0.031

The above figures are approximate and for
container shipment.

SPECIAL FHP MOTORS

MOTORS FOR 60 Hz SUPPLY

The 56 Frame Motors can be supplied for 115 V and 220/240 V, 60 Hz as called for in the North American and some other markets, for general purpose and customer specific applications to NEMA Standards

SPECIAL APPLICATION MOTORS

In addition to General Purpose Motors, many special application motors are offered, some of which are as under

Frame 48 Motors

General purpose and specific duty motors in Frame 48 are offered for single phase 220/240V, 50Hz, and also for single phase 115V or 230V, 60Hz, supply. Option available for Ball or Sleeve Bearings, type B flange or on-site replaceable type C flange. Please let us know details of your specific requirement and we shall offer you matching motors.

Roller Door Drive Motors

- 0.37 kW, 4 poles, 56 frame foot mounted, DP, PSC motors, 10 minute rated, reversing type with identical main and auxiliary winding requiring simple and economical control gear and suitable for single phase 240V, 50 Hz AC supply.
- 0.37 kW, 4 poles, 415V, 50 Hz, 3 phase, DP, 10 minute rated, foot mounted motors.
- 0.75 kW, 4 poles, 415V, 50 Hz, 3 phase, TE, 10 minute rated, foot mounted motors.

Compressor Motors

Specially designed, 2 Pole Compressor Duty motors for single phase, 220/240V,

Metric Flange Motors

Single Phase, TEFC motors with metric flange and shaft diameter for typical drive of gear box, centrifugal water pump etc. 4 pole motors for gear box drive are supplied with oil seal.

kW	POLES	TYPE	FRAME	FLANGE
0.37	4	CS	C56	D 71
0.37	4	SS	C56	D 71
0.55	4	CS	C58	D 80
0.55	4	SS	C58	D 80
0.75	4	CSCR	C58	D 80
1.1	4	CSCR	Q104	D 100*
1.5	4	CSCR	Q104	D 100*
2.2	4	CSCR	Q105	D 100*
0.37	2	CS	C54	D 71
0.37	2	PSC	C52	D 71
0.55	2	CS	C56	D 80
0.55	2	PSC	C56	D 80
0.75	2	CS	C58	D 80
0.75	2	PSC	C56	D 80
1.1	2	CS	C58	D 80
1.1	2	PSC	C58	D 80
1.3	2	CSCR	C59	D 80
1.5	2	CSCR	C59	D 80

* Please refer drawing for non-standard shaft diameter.

Washing Machine Motors

We offer special motors for Twin Tub type Washing Machine, Tumble type Washing Machine and Agitator type Washing Machine. Please refer to us with detailed specifications.

50Hz, in Frame 56 with 19.2 mm (3/4") shaft diameter are offered as under

HP	FRAME	ENCLOSURE	TYPE	RATED FL		TORQUE % FLT		CAP MFD	I(ST) AMPS	EFF %	POWER FACTOR
				AMPS	WATTS	STT	POT				
1.5	C58	DPFC	CSCR	7.5	1550	220	200	160+10	40	72	0.64
1.75	C58	DPFC	CSCR	8.4	1800	220	200	200+15	45	72	0.64
2.0	C58	DPFC	CSCR	9.9	2100	250	190	200+15	50	71	0.88
2.7	C59	DPFC	CSCR	14.8	3050	275	230	200+30	90	66	0.86

PSC Pump Motors

Single Phase, 220/240V, 50 Hz, 2 Pole Motors in Frame 56.

HP	FRAME	ENCLOSURE	FULL LOAD AMP	% FULL LOAD			CAPACITOR MFD	I (ST) AMPS	%EFF	PF
				W/ATTS	STT	BDT				
0.5	C52	DP/TEFC	2.3	500	50	220	10.0	13.0	74.0	0.96
1.0	C56	DP/TEFC	5.0	1180	50	220	25.0	25.0	63.2	1.0
1.5	C58	DP/TEFC	6.8	1520	25	220	30.0	25.0	74.6	0.97

Single Phase, 220/240V, 50 Hz, 4 Pole Motors in Frame 56.

HP	FRAME	ENCLOSURE	FULL LOAD AMP	% FULL LOAD			CAPACITOR MFD	I (ST) AMPS	%EFF	PF
				W/ATTS	STT	BDT				
0.25	C52	DP/TEFC	2.1	350	30	250	6.3	12.0	51.0	0.72
0.5	C54	DP/TEFC	4.0	600	30	250	8.0	16.0	61.0	0.65
1.0	C58	TEFC	5.0	1120	30	250	25.0	30.0	65.0	1.0

STT - Starting Torque, BDT - Breakdown Torque
Please note PSC motors are suitable for centrifugal pumps only. For other pump applications please refer to us with details

DIMENSIONS

1556

DIMENSIONAL DRAWING

FRAME C50 MOTOR, RIGID BASE MOUNTING, TO BS 204

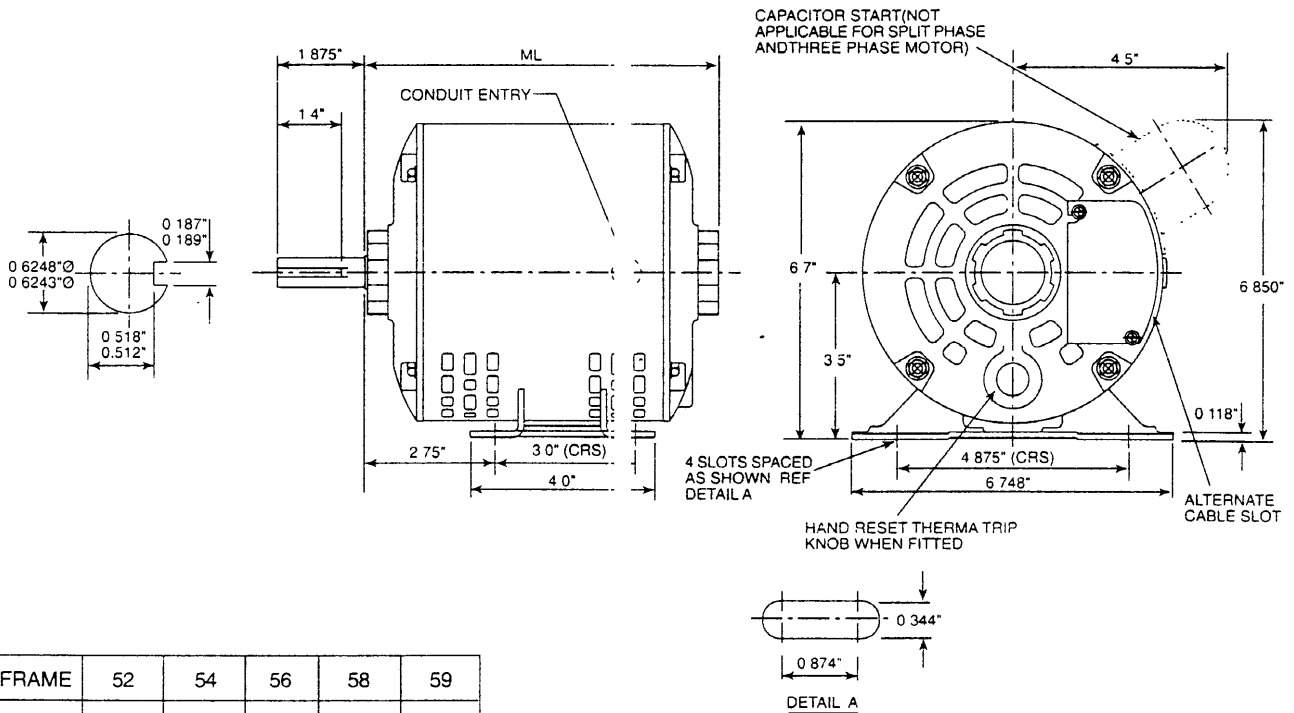

FRAME	52	54	56	58	59
ML	7.9	8.5	9.1	9.7	10.3

REF. BKF 197

FRAME C50 MOTOR, 'C' FLANGE MOUNTING, TO BS 204

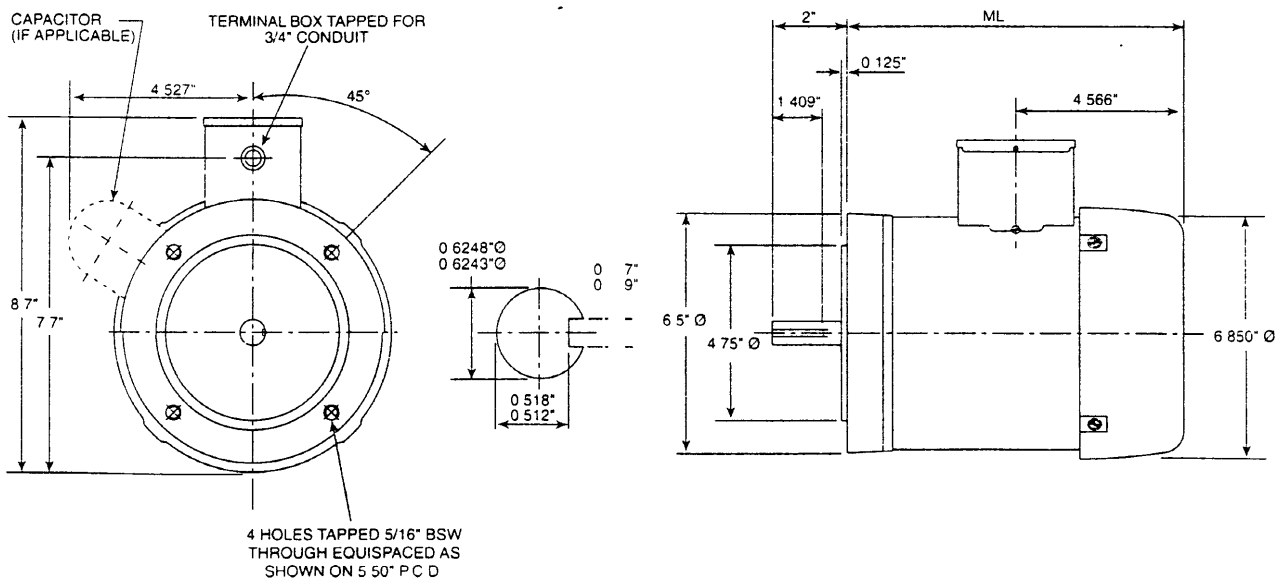

FRAME	52	54	56	58	59
ML	9.2"	9.8"	10.4"	11.0"	11.6"

REF. BKF 199

DIMENSIONS

DIMENSIONAL DRAWING (continued)

FRAME C50 MOTOR, 'C' FLANGE MOUNTING, TO NEMA STANDARD

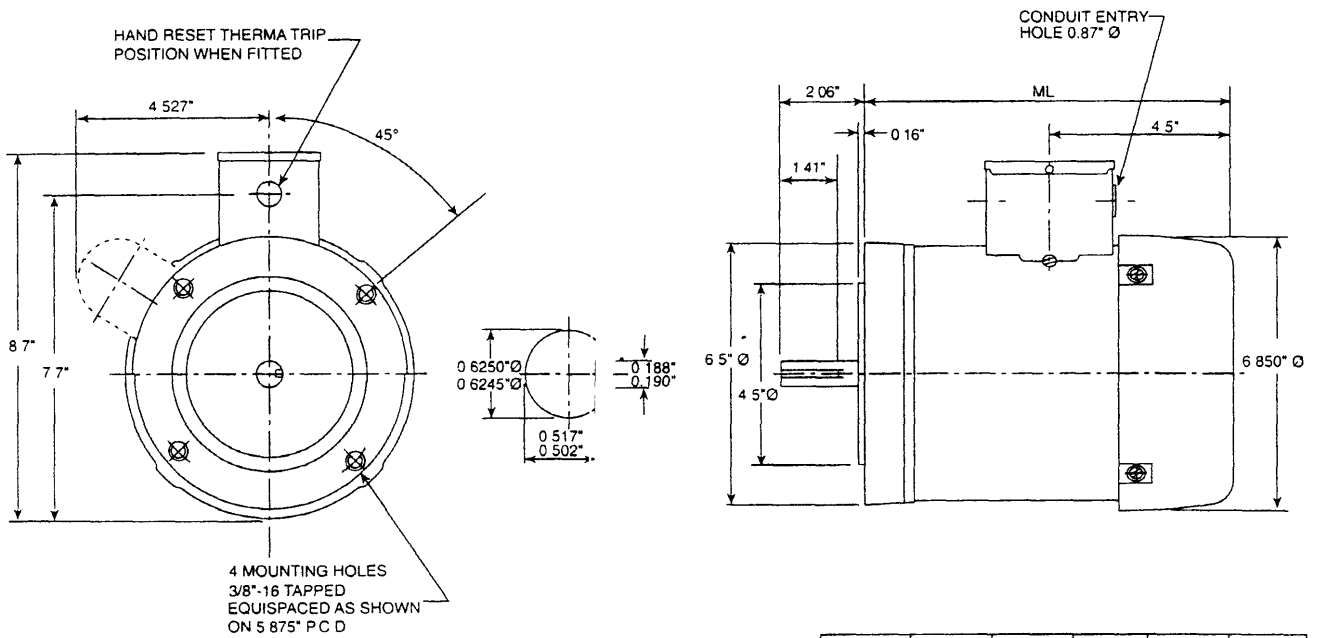

REF : BKF 194

FRAME	52	54	56	58	59
ML	9.2"	9.8"	10.4"	11.0"	11.6"

FRAME C50 MOTOR, RESILIENT BASE MOUNTING, TO NEMA STANDARD

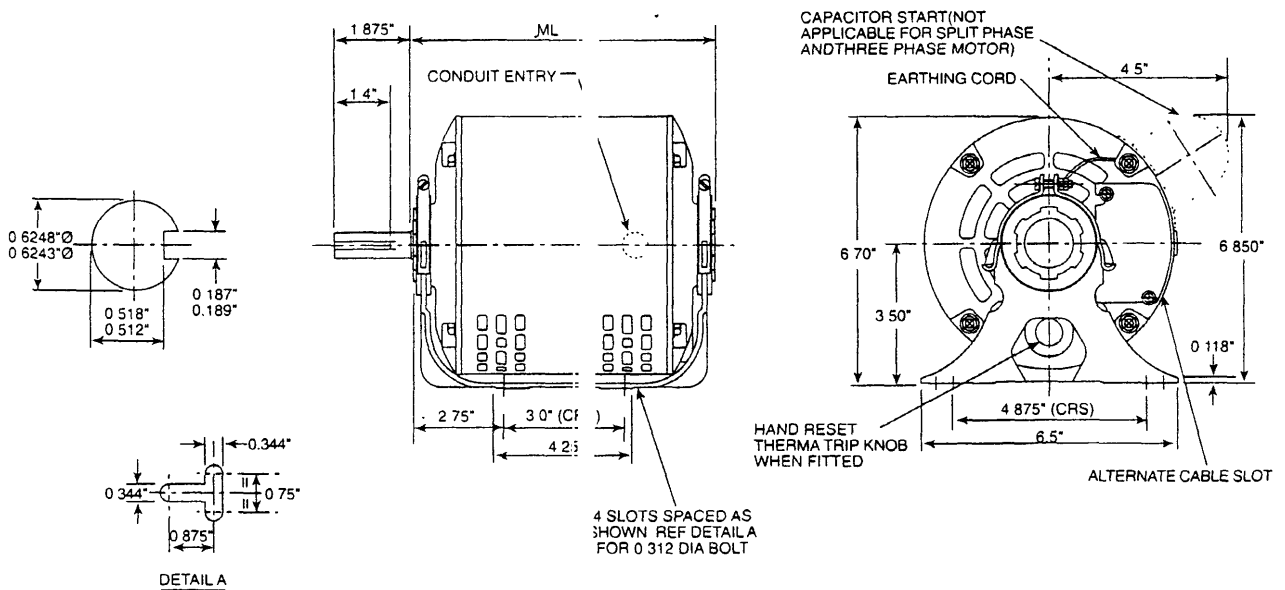

REF BKF 203

FRAME	52	54	56	58	59
ML	7.9"	8.5"	9.1"	9.7"	10.3"

DIMENSIONS

DIMENSIONAL DRAWING (continued)

FRAME B48 MOTOR, RIGID BASE OR STUD MOUNTING, TO BS 2048

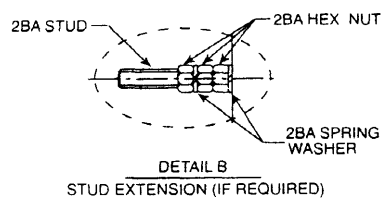
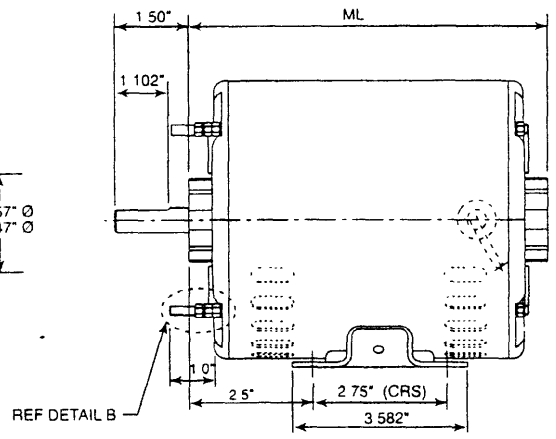
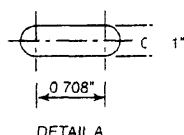
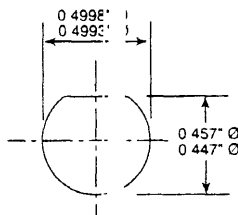
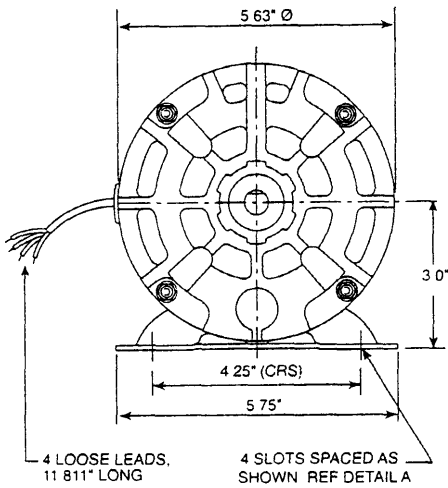

FRAME	41	42	44	46	48	49
ML	5.0"	5.4"	5.8"	6.2"	6.8"	7.4"

REF : BKF 195

FRAME B48 MOTOR, 'C' FLANGE MOUNTING, TO BS 2048

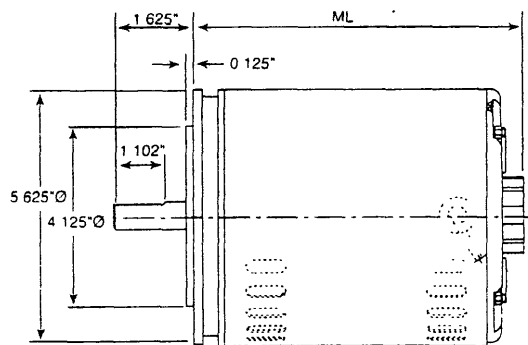
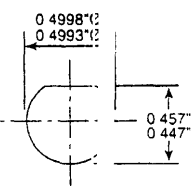
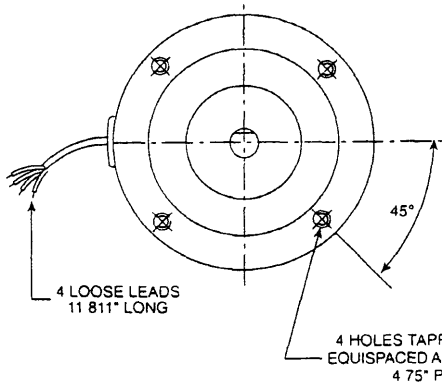

FRAME	41	42	44	46	48	49
ML	4.9"	5.3"	5.7"	6.1"	6.7"	7.2"

REF BKF 200

DIMENSIONAL DRAWING (continued)

FRAME B48 MOTOR, "C" FLANGE MOUNTING, TO NE 1A

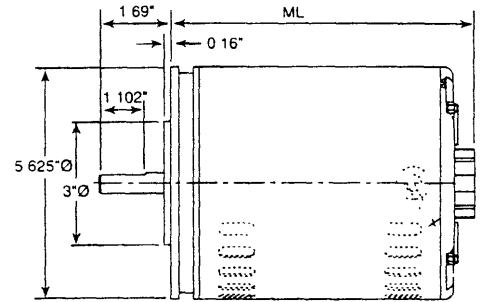
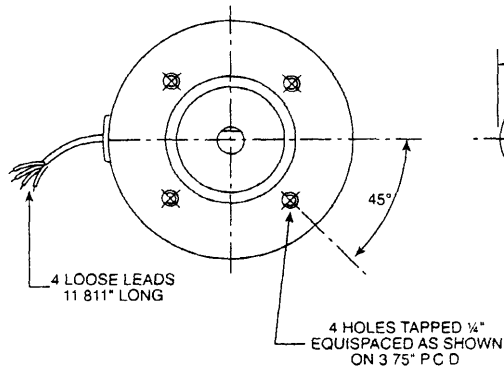

REF : BKF 201

FRAME	41	42	44	46	48	49
ML	4.9"	5.3"	5.7"	6.1"	6.7"	7.2"

FRAME B48 MOTOR, RESILIENT BASE MOUNTING, O BS 2048

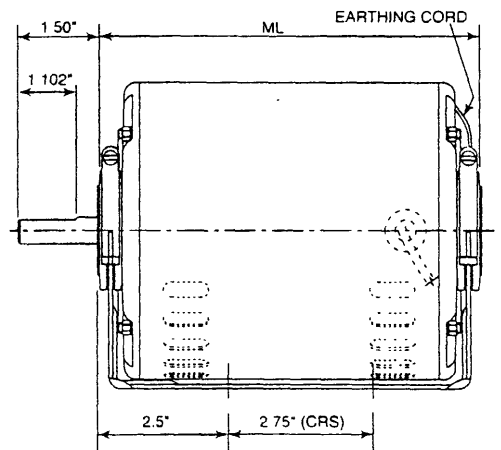
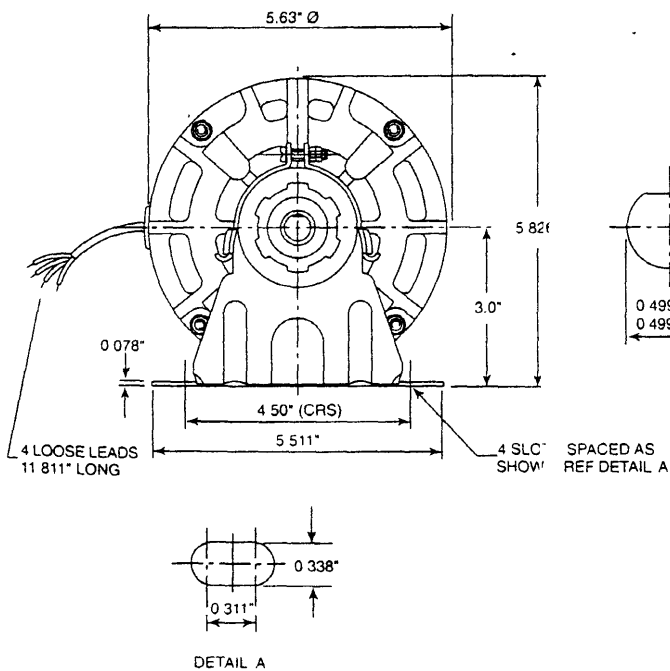

REF : BKF 196

FRAME	41	42	44	46	48	49
ML	5.0"	5.4"	5.8"	6.2"	6.8"	7.4"

DIMENSIONS

DIMENSIONAL DRAWING (continued)

FRAME C56 AND 100S MOTOR, METRIC FLANGE MOUNTING TO IEC

FRAME C 56
FLANGE D 71

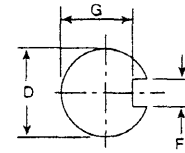
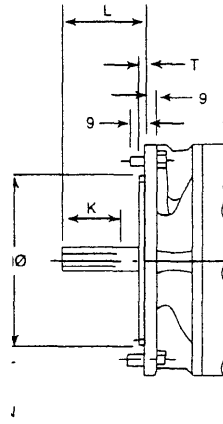
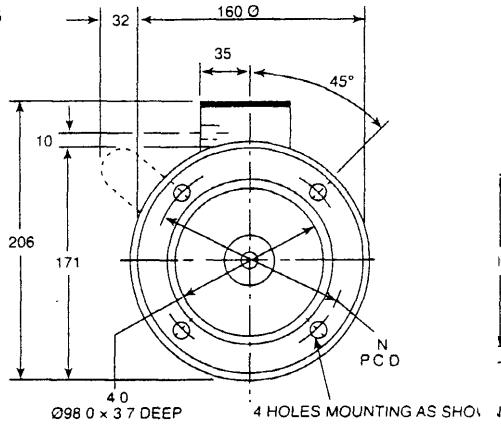

FRAME C 56
FLANGE D 80

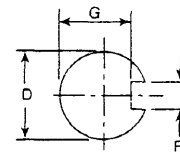
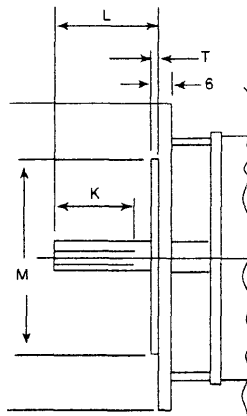
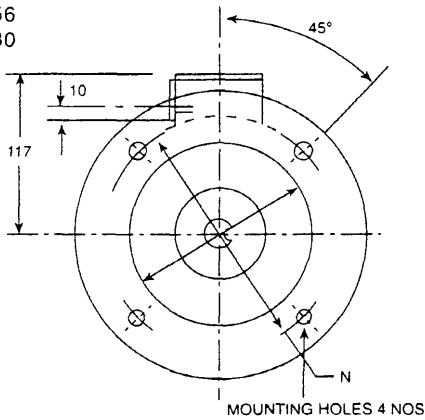

FRAME 100 S
FLANGE D 100 S

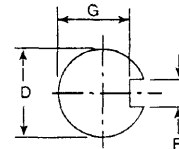
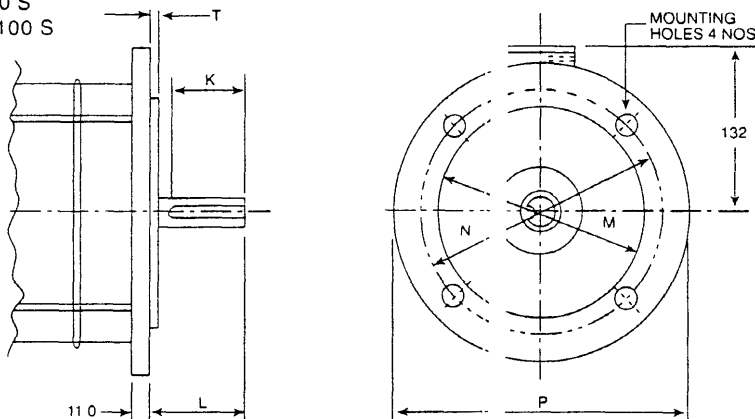

Frame	Flange	M Ø ⁺⁰ _{-0.08}	N Ø ^{+0.3}	P Ø	Mounting Holes	L	D Ø	F	G	K
C 56	D 71	110	130	-	10 Ø	30	14 008 13 997	5 ^{+0.0} -0.03	11.00 10.90	22.0
C 56	D 80	130	165	200	12 Ø	40	19.009 18.996	6 ^{+0.0} -0.03	15.50 15.40	28.0
100 S	D 100 S	180	125	250	15 Ø	50	24.009 23.996	8 ^{+0.03} -0.0	20.20 20.00	37.0

- Please note shaft diameter for 100S Frame motor is 24mm as 28mm cannot be provided
- Supply terminal box will have M20x1 5P conduit entry
- For ML dimension and capacitor configuration please refer respective motor drawing
- All dimensions are in mm.

DIMENSIONS

DIMENSIONAL DRAWING (continued)

FRAME 100S MOTOR, RIGID BASE MOUNTING, TO IEC

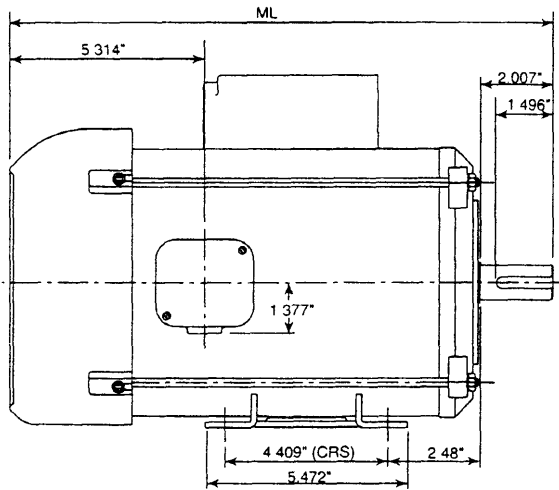

REF · BKF193

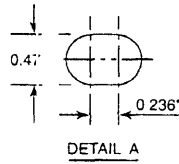
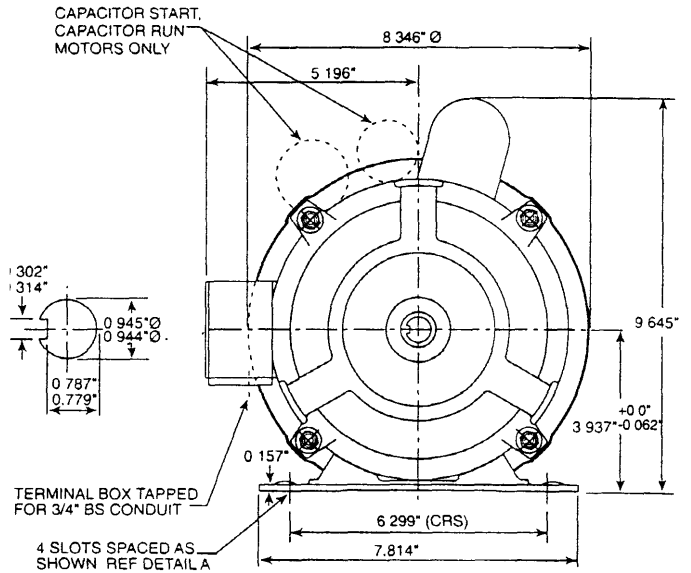

FRAME	103	104	106
ML	12.992"	13.779"	14.763"

All above drawings and dimensions are subject to confirmation. Certified drawings can be given on request

FHP MOTORS SELECTION

BY PERFORMANCE

Typical Performance Characteristics

	Single phase				3 Phase
	Split Phase	Cap-Start	Cap Start & Run	Shaded Pole	
Starting Torque (% FLT)	180	280	40	20	200
Run-Up Torque (% FLT)	165	190	35	35	200
Pull-Out Torque (% FLT)	200	200	190	150	250
Starting Current (% FLC)	800/1100	500	400	200	600
Starting Cycle, Starts per hour each max. 1/2 second	10	15	60	60	60
Full Load Efficiency %	50/60	50/60	0/60	30	60/80
Speed Variation*	No	No	Yes	Yes	Yes
Remarks	High starting current	Capacitor is short time rated	Low starting torque	Low starting torque, low efficiency.	-

* Speed variation available against fan load with variable supply voltage.

BY APPLICATION

Popular Single Phase Drive Selections

Duty	Motor	Appropriate characteristics
Compressor	Cap-Start	High starting torque
High-Inertia Blower	Cap-Start & Run	Absence of centrifugal switch because of slow acceleration.
Centrifugal Pumps	Split Phase	Starting performance
	Cap-Start	Preferred above 370 watt due to lower starting current.
Fans-Centrifugal or Axial	Split Phase	Starting performance.
	Cap-Start	Preferred above 370 watts due to lower starting current.
	Cap-Start & Run	Availability of variable speed, subject to torque being adequate.
	Shaded-Pole	Availability of variable speed, subject to torque being adequate.
Washing Machine	Split Phase	Starting performance
	Cap-Start	Usually superior starting performance.
Oil Burners	Split Phase	Starting performance
	Cap-Start	Preferred above 370 watt due to lower starting current.
Office Machinery	Split Phase	Starting performance
	Cap-Start	Preferred above 370 watt due to lower starting current.

The widest Range of Motors, Alternators and Pumps from Crompton Greaves

Single Phase / Three Phase FHP Motors (FHP Range)

- From 90 watts to 2.25kW to BS 5000 part 11 or NEMA
- Frame 48, Frame 56 and Frame 100S covering a wide range.
- DP, TEFC and TE(AOM) enclosures.
- General Purpose and Customer Specific.
- For 120 Volts or 240 Volts, 50/60Hz. supply suitability.
- With CSA NRTL/C mark for Canada and USA and with CE mark for Europe.

Standard Three Phase, LT, Induction Motors (M1 and M3 Range)

- From 0.18kW to 250kW, SCR and SR to IEC 325.
- Frames 63 to 355L.
- DP, TEFC, TE, Flame proof (Type 'd'), Increased Safety (Type 'e'), Non-sparking (Type 'n'), Pressurised (Type 'p') enclosures etc.
- For 110 to 660 volts, 50/60Hz supply.
- Under CSA NRTL/C listing for Canada and USA and with CE mark for Europe.
- S1 to S8 Duty Cycles for all applications.

Three Phase, LT, Induction Motors (Large Machines Range)

- From 150kW upto 1000kW, SCR and SR.
- Frames 315 to 710, 2 pole to 14 pole.
- TEFC, DP, Type 'd', Type 'e', Type 'n', Type 'p' enclosures.
- Vertical and horizontal, foot cum flange mounting.
- For 400 to 690 volts, 50/60 Hz supply.
- S1 to S8 Duty Cycles for all applications.

- Standard Re-Rolling Mill Duty motors and Special Dual Speed Induction Generators for Wind Mill Duty.

Three Phase, HT, Induction and Synchronous Machines (Large Machines Range)

- Upto 6000 kW, SCR and SR. (Range being extended upto 8 MW)
- Upto 20 poles.
- CACA, TETV, SPDP, CACW, Flame proof, Type 'e', Type 'n', Type 'p' enclosures.
- For 2.2kV, 3.3kV, 6.6kV, 11kV, 14.3kV, 50/60 Hz supply.
- "Resin-Rich" alternatively "Resin-Poor" HIPACT- Hitachi Insulation offered.
- S1 to S8 duty cycles for all applications.

Alternators

- From 5 KVA to 250 KVA, to generate 240 Volts, 0.8PF, 50/60 Hz, single phase and 415 Volts, 0.8PF, 50/60Hz, three phase, AC supply at 1500/1800 rpm, conforming to BS5000 (Part 99).
- Brush and Brushless designs, revolving armature and revolving field types, with self excited and self regulated exciter units.
- For general purpose, marine and pulley drive applications.

Pumps

- For Water Circulation Applications.
- For single phase, and three phase supply.
- With 250 Watts to 80 kW motors.
- Coupled, Monoblocks, Submersibles, Jet Centrifugals, In Line Pumps for Industrial, Agricultural and Commercial applications.