



256K x 32 Static RAM Module

Features

- **High-density 8-megabit SRAM module**
- **32-bit standard footprint supports densities from 16K x 32 through 1M x 32**
- **High-speed CMOS SRAMs**
 - Access time of 12 ns
- **Low active power**
 - 5.3W (max.) at 25 ns
- **SMD technology**
- **TTL-compatible inputs and outputs**
- **Low profile**
 - Max. height of 0.58 in.
- **Available in ZIP, SIMM, and angled SIMM footprint**
- **72-pin SIMM version compatible with 1M x 32 (CYM1851)**

Functional Description

The CYM1841A/B/C are high-performance 8-megabit static RAM modules organized as 256K words by 32 bits. This module is constructed from eight 256K x 4 SRAMs (1841A/C) or 256K x 16 SRAMs (1841B) in SOJ packages mounted on an epoxy laminate board with pins. Four chip selects (\overline{CS}_1 , \overline{CS}_2 , \overline{CS}_3 , \overline{CS}_4) are used to independently enable the four bytes.

Reading or writing can be executed on individual bytes or any combination of multiple bytes through proper use of selects.

Writing to each byte is accomplished when the appropriate Chip Select (\overline{CS}) and Write Enable (\overline{WE}) inputs are both LOW. Data on the Input/Output pins (I/O) is written into the memory location specified on the address pins (A_0 through A_{17}).

Reading the device is accomplished by taking the Chip Select (\overline{CS}) LOW while Write Enable (\overline{WE}) remains HIGH. Under these conditions, the contents of the memory location specified on the address pins will appear on the data Input/Output pins (I/O).

The data input/output pins stay at the high-impedance state when write enable is LOW or the appropriate chip selects are HIGH.

Two pins (PD_0 and PD_1) are used to identify module memory density in applications where alternate versions of the JEDEC-standard modules can be interchanged.

The CYM1841A, CYM1841B, and CYM1841C are 100% pin, package, and electrically identical. The CYM1841A utilizes corner power and ground SRAMs, the CYM1841B utilizes 256K x 16 SRAMs, the CYM1841C utilizes center power and ground SRAMs.

A 72-pin SIMM is offered for compatibility with the 1M x 32 CYM1851. This version is socket upgradable to the CYM1851.

Both the 64-pin and 72-pin SIMM modules are available with either tin-lead or 10 micro-inches of gold flash on the edge contacts.

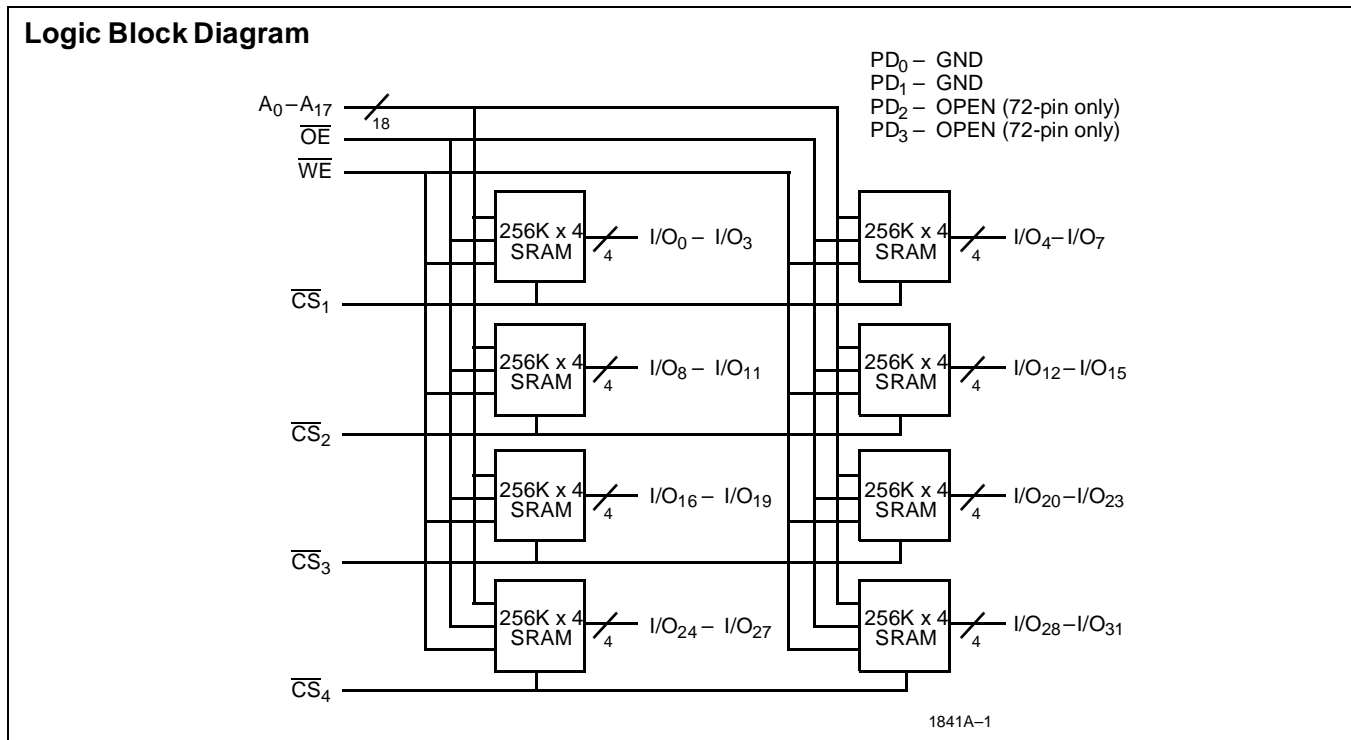

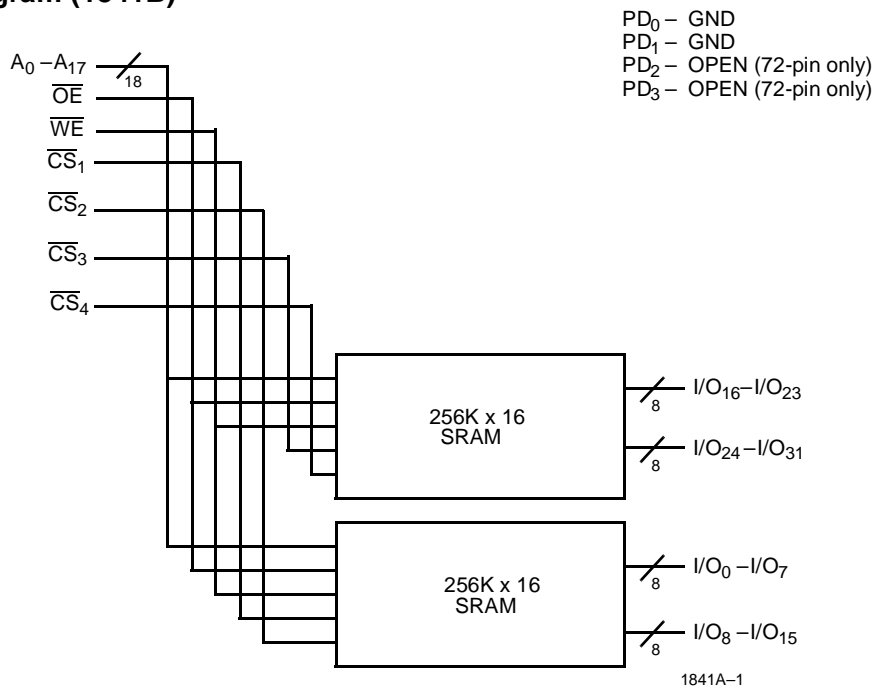
Logic Block Diagram (1841B)

Selection Guide

	1841C-12	1841B/C-15	1841A/B/C-20	1841A/B/C-25	1841A/B/C-35	1841A/B/C-45
Maximum Access Time (ns)	12	15	20	25	35	45
Maximum Operating Current (mA)	1600	1600	1120	960	960	960
Maximum Standby Current (mA)	480	480	480	480	480	480

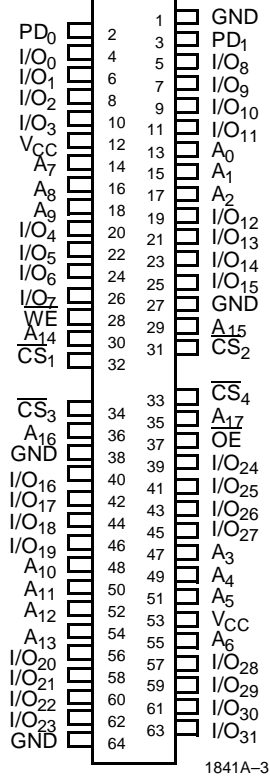
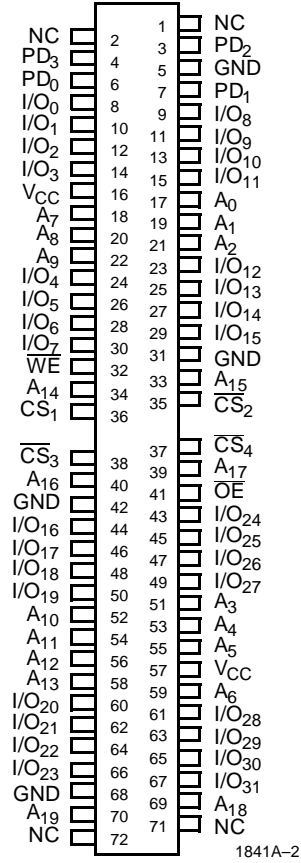
Shaded areas contain preliminary information.

Pin Configurations
**64-Pin
ZIP/SIMM
Top View**

**72-Pin
SIMM
Top View**



Maximum Ratings

(Above which the useful life may be impaired. For user guidelines, not tested.)

Storage Temperature -55°C to +125°C
Ambient Temperature with
Power Applied -10°C to +85°C
Supply Voltage to Ground Potential..... -0.5V to +7.0V

DC Voltage Applied to Outputs

in High Z State -0.5V to +7.0V

DC Input Voltage -0.5V to +7.0V

Operating Range

Range	Ambient Temperature	V _{CC}
Commercial	0°C to +70°C	5V ± 10%

Electrical Characteristics Over the Operating Range

Parameter	Description	Test Conditions	1841C-12 1841B/C-15		1841A/B/C -20		1841A/B/C -25, 35, 45		Unit
			Min.	Max.	Min.	Max.	Min.	Max.	
V _{OH}	Output HIGH Voltage	V _{CC} = Min., I _{OH} = -4.0 mA	2.4		2.4		2.4		V
V _{OL}	Output LOW Voltage	V _{CC} = Min., I _{OL} = 8.0 mA		0.4		0.4		0.4	V
V _{IH}	Input HIGH Voltage		2.2	V _{CC}	2.2	V _{CC}	2.2	V _{CC}	V
V _{IL}	Input LOW Voltage		-0.5	0.8	-0.5	0.8	-0.5	0.8	V
I _{IX}	Input Leakage Current	GND ≤ V _I ≤ V _{CC}	-16	+16	-16	+16	-16	+16	mA
I _{OZ}	Output Leakage Current	GND ≤ V _O ≤ V _{CC} , Output Disabled	-10	+10	-10	+10	-10	+10	mA
I _{CC}	V _{CC} Operating Supply Current	V _{CC} = Max., I _{OUT} = 0 mA, CS ≤ V _{IL}		1600		1120		960	mA
I _{SB1}	Automatic CS Power-Down Current ^[1]	Max. V _{CC} , CS ≥ V _{IH} , Min. Duty Cycle = 100%		480		480		480	mA
I _{SB2}	Automatic CS Power-Down Current ^[1]	Max. V _{CC} , CS ≥ V _{CC} - 0.2V, V _{IN} ≥ V _{CC} - 0.2V, or V _{IN} ≤ 0.2V		240		200		200	mA

Capacitance^[2]

Parameter	Description	Test Conditions	Max.	Unit
C _{IN}	Input Capacitance ^[3]	T _A = 25°C, f = 1 MHz, V _{CC} = 5.0V	70/20	pF
C _{OUT}	Output Capacitance		20	pF

Notes:

1. A pull-up resistor to V_{CC} on the CS input is required to keep the device deselected during V_{CC} power-up, otherwise I_{SB} will exceed values given.
2. Tested on a sample basis.
3. 20 pF on CS, 70 pF all others.

AC Test Loads and Waveforms

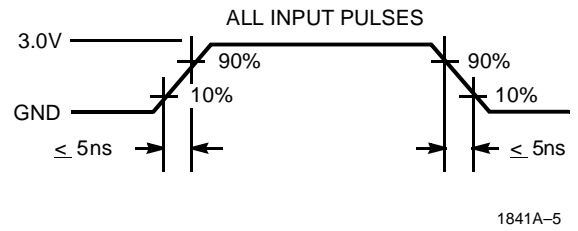
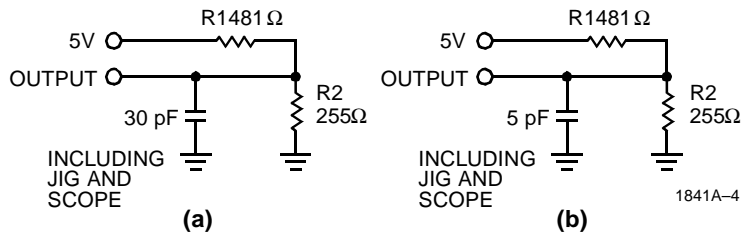

Equivalent to: THÉVENIN EQUIVALENT

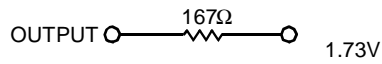

Switching Characteristics Over the Operating Range^[4]

Parameter	Description	1841C-12		1841B/C-15		1841A/B/C-20		1841A/B/C-25		Unit
		Min.	Max.	Min.	Max.	Min.	Max.	Min.	Max.	
READ CYCLE										
t _{RC}	Read Cycle Time	12		15		20		25		ns
t _{AA}	Address to Data Valid		12		15		20		25	ns
t _{OHA}	Output Hold from Address Change	3		3		3		3		ns
t _{ACS}	\overline{CS} LOW to Data Valid		12		15		20		25	ns
t _{DOE}	\overline{OE} LOW to Data Valid		7		8		13		15	ns
t _{LZOE}	\overline{OE} LOW to Low Z	0		0		0		0		ns
t _{HZOE}	\overline{OE} HIGH to High Z		7		8		15		15	ns
t _{LZCS}	\overline{CS} LOW to Low Z ^[5]	3		3		10		10		ns
t _{HZCS}	\overline{CS} HIGH to High Z ^[5, 6]		7		8		20		20	ns
t _{PD}	\overline{CS} HIGH to Power-Down		12		15		20		25	
WRITE CYCLE^[7]										
t _{WC}	Write Cycle Time	12		15		20		25		ns
t _{SCS}	\overline{CS} LOW to Write End	9		10		15		20		ns
t _{AW}	Address Set-Up to Write End	9		10		18		20		ns
t _{HA}	Address Hold from Write End	0		0		0		0		ns
t _{SA}	Address Set-Up to Write Start	2		2		2		2		ns
t _{PWE}	\overline{WE} Pulse Width	10		13		15		20		ns
t _{SD}	Data Set-Up to Write End	7		8		13		15		ns
t _{HD}	Data Hold from Write End	1		1		2		2		ns
t _{LZWE}	\overline{WE} HIGH to Low Z	0		0		0		0		ns
t _{HZWE}	\overline{WE} LOW to High Z ^[6]	0	5	0	7	0	15	0	15	ns

Shaded areas contain preliminary information.

Notes:

4. Test conditions assume signal transition times of 5 ns or less, timing reference levels of 1.5V, input pulse levels of 0 to 3.0V, and output loading of the specified I_{OL}/I_{OH} and 30-pF load capacitance.
5. At any given temperature and voltage condition, t_{HZCS} is less than t_{LZCS} for any given device. These parameters are guaranteed by design and not 100% tested.
6. t_{HZCS} and t_{HZWE} are specified with C_L = 5 pF as in part (b) of AC Test Loads and Waveforms. Transition is measured ±500 mV from steady-state voltage.
7. The internal write time of the memory is defined by the overlap of \overline{CS} LOW and \overline{WE} LOW. Both signals must be LOW to initiate a write and either signal can terminate a write by going HIGH. The data input set-up and hold timing should be referenced to the rising edge of the signal that terminates the write.



Switching Characteristics Over the Operating Range¹⁴

Parameter	Description	1841A/B/C-35		1841A/B/C-45		Unit
		Min.	Max.	Min.	Max.	
READ CYCLE						
t _{RC}	Read Cycle Time	35		45		ns
t _{AA}	Address to Data Valid		35		45	ns
t _{OHA}	Data Hold from Address Change	3		3		ns
t _{ACS}	\overline{CS} LOW to Data Valid		35		45	ns
t _{DOE}	\overline{OE} LOW to Data Valid		25		30	ns
t _{LZOE}	\overline{OE} LOW to Low Z	0		0		ns
t _{HZOE}	\overline{OE} LOW to High Z		15		15	ns
t _{LZCS}	\overline{CS} LOW to Low Z ^[5]	10		10		ns
t _{HZCS}	\overline{CS} HIGH to High Z ^[5, 6]		20		20	ns
t _{PD}	\overline{CS} HIGH to Power-Down		35		45	ns
WRITE CYCLE^[7]						
t _{WC}	Write Cycle Time	35		45		ns
t _{SCS}	\overline{CS} LOW to Write End	30		40		ns
t _{AW}	Address Set-Up to Write End	30		40		ns
t _{HA}	Address Hold from Write End	2		2		ns
t _{SA}	Address Set-Up to Write Start	2		2		ns
t _{PWE}	\overline{WE} Pulse Width	30		35		ns
t _{SD}	Data Set-Up to Write End	20		25		ns
t _{HD}	Data Hold from Write End	2		2		ns
t _{LZWE}	\overline{WE} HIGH to Low Z	0		0		ns
t _{HZWE}	\overline{WE} LOW to High Z ^[6]	0	15	0	15	ns

Switching Waveforms

Read Cycle No. 1^[8, 9]

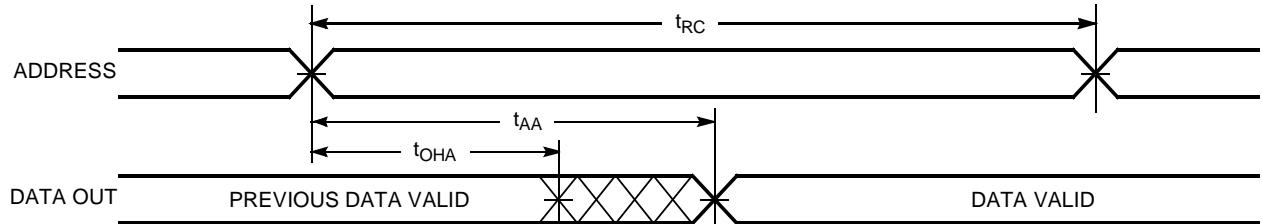

1841A-6

Read Cycle No. 2^[8, 10]

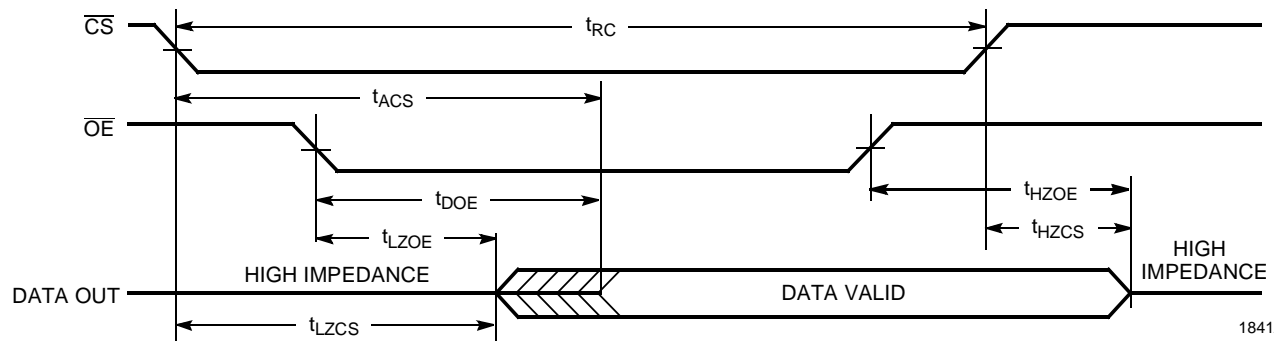

1841A-7

Write Cycle No. 1 (\overline{WE} Controlled)^[7]

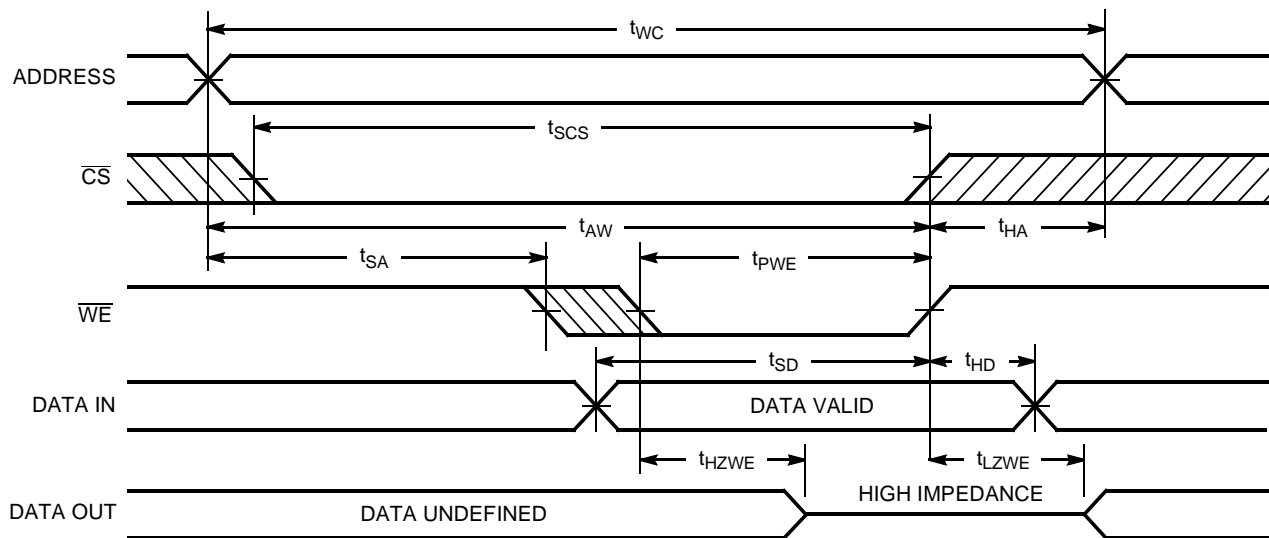

1841A-8

Notes:

8. \overline{WE} is HIGH for read cycle.
9. Device is continuously selected, $\overline{CS} = V_{IL}$ and $\overline{OE} = V_{IL}$.
10. Address valid prior to or coincident with \overline{CS} transition LOW.

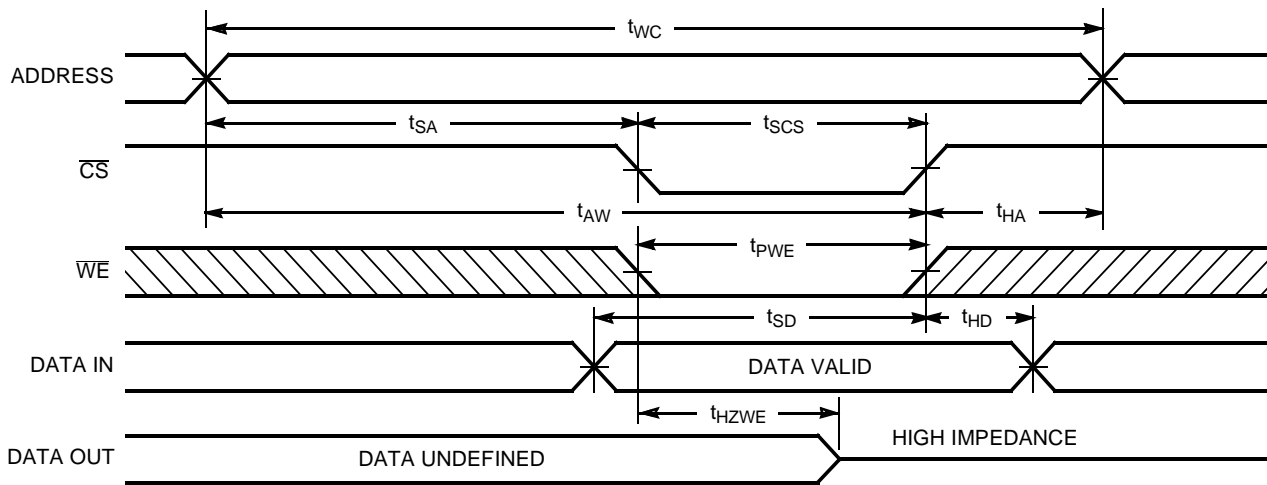
Switching Waveforms (continued)
Write Cycle No. 2 (\overline{CS} Controlled)^[7, 11]

1841A-9

Note:

 11. If \overline{CS} goes HIGH simultaneously with \overline{WE} HIGH, the output remains in a high-impedance state.

Truth Table

\overline{CS}	\overline{WE}	\overline{OE}	Input/Output	Mode
H	X	X	High Z	Deselect/Power-Down
L	H	L	Data Out	Read
L	L	X	Data In	Write
L	H	H	High Z	Deselect



Ordering Information

Speed (ns)	Ordering Code	Package Name	Package Type	Operating Range
12	CYM1841CPM-12C	PM02	64-Pin Plastic SIMM Module	Commercial
	CYM1841CP7-12C	PM04	72-Pin Plastic SIMM Module	
	CYM1841CPZ-12C	PZ03	64-Pin Plastic ZIP Module	
15	CYM1841APM15C	PM02	64-Pin Plastic SIMM Module	Commercial
	CYM1841APY-15C	PM01	64-Pin Plastic SIMM Module (gold contacts)	
	CYM1841APT-15C	PM01	64-Pin Plastic SIMM Module	
	CYM1841AP5-15C	PN04	72-Pin Plastic Angled SIMM Module	
	CYM1841AP6-15C	PM01	72-Pin Plastic Angled SIMM Module (gold contacts)	
	CYM1841AP7-15C	PM04	72-Pin Plastic SIMM Module	
	CYM1841AP8-15C	PM04	72-Pin Plastic SIMM Module (gold contacts)	
	CYM1841APN-15C	PN02	64-Pin Plastic Angled SIMM Module	
	CYM1841APR-15C	PZ01	64-Pin Plastic ZIP Module	
	CYM1841APZ-15C	PZ03	64-Pin Plastic ZIP Module	
	CYM1841BPZ-15C	PZ03	64-Pin Plastic ZIP Module	
	CYM1841BP7-15C	PM04	72-Pin Plastic SIMM Module	
20	CYM1841APM-20C	PM02	64-Pin Plastic SIMM Module	Commercial
	CYM1841APY-20C	PM01	64-Pin Plastic SIMM Module (gold contacts)	
	CYM1841APT-20C	PM01	64-Pin Plastic SIMM Module	
	CYM1841AP5-20C	PN04	72-Pin Plastic Angled SIMM Module	
	CYM1841AP6-20C	PM01	72-Pin Plastic Angled SIMM Module (gold contacts)	
	CYM1841AP7-20C	PM04	72-Pin Plastic SIMM Module	
	CYM1841AP8-20C	PM04	72-Pin Plastic SIMM Module (gold contacts)	
	CYM1841APN-20C	PN02	64-Pin Plastic Angled SIMM Module	
	CYM1841APR-20C	PZ01	64-Pin Plastic ZIP Module	
	CYM1841APZ-20C	PZ03	64-Pin Plastic ZIP Module	
	CYM1841BPZ-20C	PZ03	64-Pin Plastic ZIP Module	
	CYM1841BP7-20C	PM04	72-Pin Plastic SIMM Module	
25	CYM1841APM-25C	PM02	64-Pin Plastic SIMM Module	Commercial
	CYM1841APY-25C	PM01	64-Pin Plastic SIMM Module (gold contacts)	
	CYM1841APT-25C	PM01	64-Pin Plastic SIMM Module	
	CYM1841AP5-25C	PN04	72-Pin Plastic Angled SIMM Module	
	CYM1841AP6-25C	PM01	72-Pin Plastic Angled SIMM Module (gold contacts)	
	CYM1841AP7-25C	PM04	72-Pin Plastic SIMM Module	
	CYM1841AP8-25C	PM04	72-Pin Plastic SIMM Module (gold contacts)	
	CYM1841APN-25C	PN02	64-Pin Plastic Angled SIMM Module	
	CYM1841APR-25C	PZ01	64-Pin Plastic ZIP Module	
	CYM1841APZ-25C	PZ03	64-Pin Plastic ZIP Module	
	CYM1841BPZ-25C	PZ03	64-Pin Plastic ZIP Module	
	CYM1841BP7-25C	PM04	72-Pin Plastic SIMM Module	

Shaded areas contain preliminary information.



Ordering Information (continued)

Speed (ns)	Ordering Code	Package Name	Package Type	Operating Range
35	CYM1841APM-35C	PM02	64-Pin Plastic SIMM Module	Commercial
	CYM1841APY-35C	PM01	64-Pin Plastic SIMM Module (gold contacts)	
	CYM1841APT-35C	PM01	64-Pin Plastic SIMM Module	
	CYM1841AP5-35C	PN04	72-Pin Plastic Angled SIMM Module	
	CYM1841AP6-35C	PM01	72-Pin Plastic Angled SIMM Module (gold contacts)	
	CYM1841AP7-35C	PM04	72-Pin Plastic SIMM Module	
	CYM1841AP8-35C	PM04	72-Pin Plastic SIMM Module (gold contacts)	
	CYM1841APN-35C	PN02	64-Pin Plastic Angled SIMM Module	
	CYM1841APR-35C	PZ01	64-Pin Plastic ZIP Module	
	CYM1841APZ-35C	PZ03	64-Pin Plastic ZIP Module	
	CYM1841BPZ-35C	PZ03	64-Pin Plastic ZIP Module	
	CYM1841BP7-35C	PM04	72-Pin Plastic SIMM Module	
45	CYM1841APM-45C	PM02	64-Pin Plastic SIMM Module	Commercial
	CYM1841APY-45C	PM01	64-Pin Plastic SIMM Module (gold contacts)	
	CYM1841APT-45C	PM01	64-Pin Plastic SIMM Module	
	CYM1841AP5-45C	PN04	72-Pin Plastic Angled SIMM Module	
	CYM1841AP6-45C	PM01	72-Pin Plastic Angled SIMM Module (gold contacts)	
	CYM1841AP7-45C	PM04	72-Pin Plastic SIMM Module	
	CYM1841AP8-45C	PM04	72-Pin Plastic SIMM Module (gold contacts)	
	CYM1841APN-45C	PN02	64-Pin Plastic Angled SIMM Module	
	CYM1841APR-45C	PZ01	64-Pin Plastic ZIP Module	
	CYM1841APZ-45C	PZ03	64-Pin Plastic ZIP Module	
	CYM1841BPZ-45C	PZ03	64-Pin Plastic ZIP Module	
	CYM1841BP7-45C	PM04	72-Pin Plastic SIMM Module	

Document #: 38-M-00031-G

Package Diagrams

64-Pin Plastic SIMM Module PM01

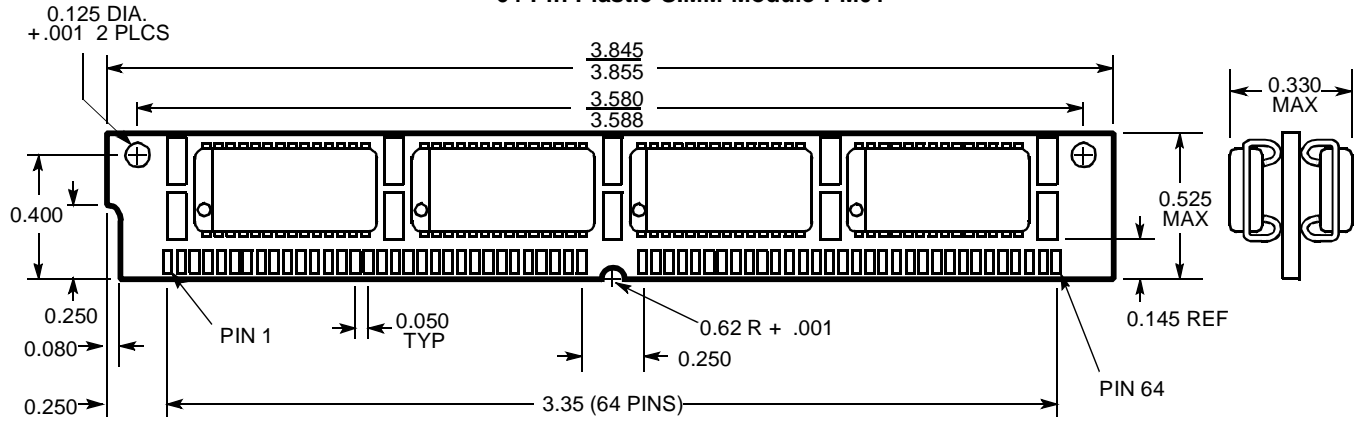

64-Pin Plastic SIMM Module PM02

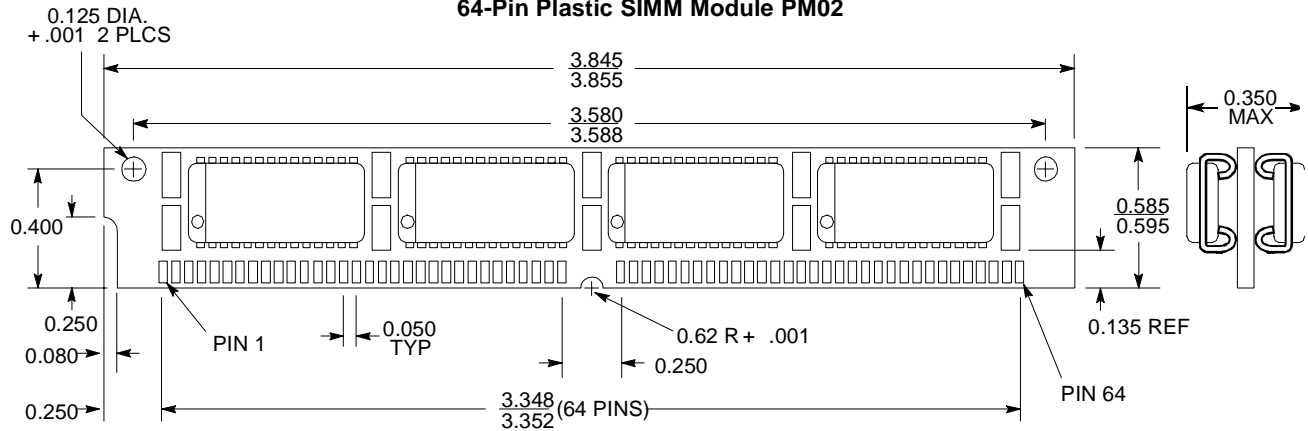

72-Pin Plastic SIMM Module PM04

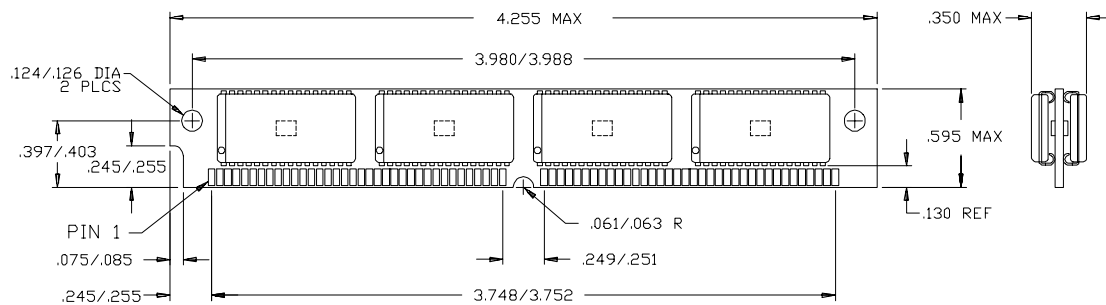

Package Diagrams (continued)

64-Pin Plastic Angled SIMM Module PN02

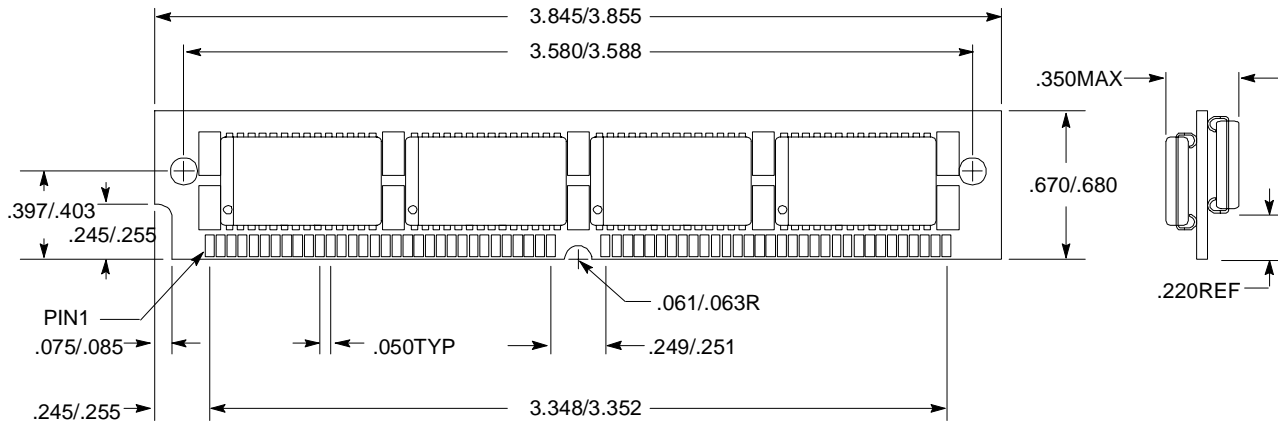

72-Pin Plastic Angled SIMM Module PN04

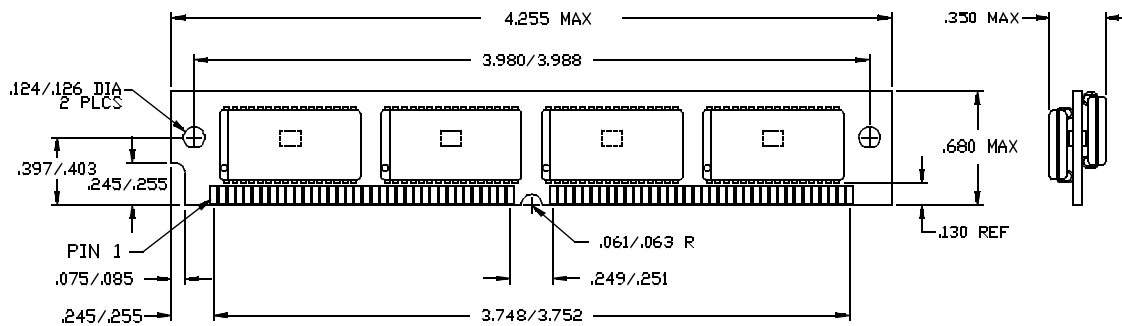

64-Pin Plastic ZIP Module PZ01

Bottom View

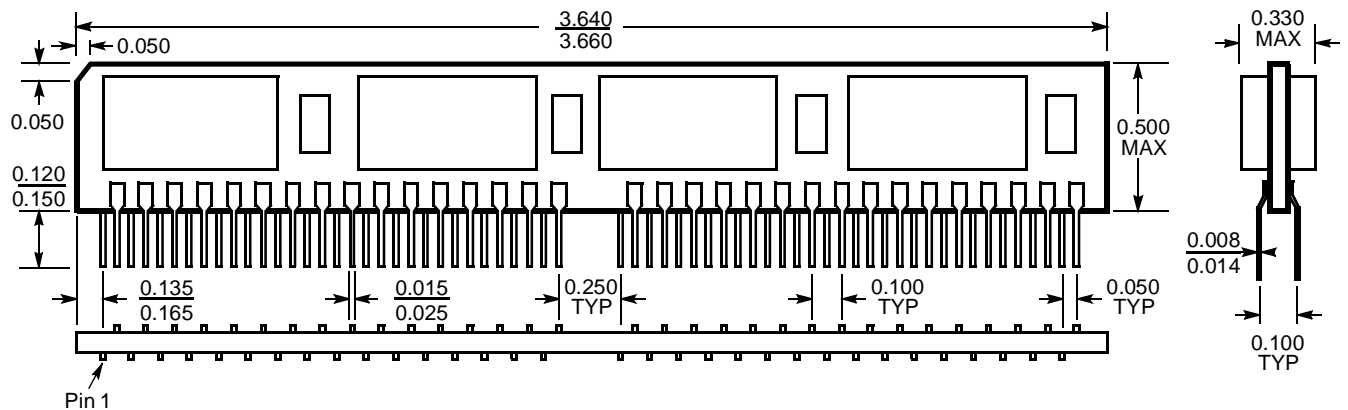

DIMENSIONS IN INCHES

MIN.
MAX.

