

DATA SHEET

PCD5043

DECT burst mode controller

Objective specification
File under Integrated Circuits, IC17

1996 Oct 31

DECT burst mode controller**PCD5043**

CONTENTS

	FEATURES
2	GENERAL DESCRIPTION
3	ORDERING INFORMATION
4	BLOCK DIAGRAM
5	PINNING
6	FUNCTIONAL DESCRIPTION
6.1	Internal bus and data memory
6.1.1	Internal Bus
6.1.2	Data Memory
6.2	Clock generation and correction
6.3	Programmable communication controller and program memory
6.3.1	PCC
6.3.2	PCC functions
6.4	Speech interface
6.4.1	12-slot mode
6.4.2	32-slot mode
6.4.3	Muting
6.4.4	Local call
6.5	RF interface
6.5.1	Serial receiver
6.5.2	Serial transmitter
6.5.3	Seamless handover
6.5.4	RF control signals
6.5.5	Synthesizer programming
6.5.6	RSSI measurement
6.5.7	Local call switching
6.5.8	Data synchronization
6.5.9	Ciphering machine
6.6	Microcontroller Interface
6.6.1	Function of the microcontroller interface
6.6.2	Microcontroller interrupts
6.6.3	Watchdog
6.6.4	Power-down
6.7	Survey of registers
7	LIMITING VALUES
8	CHARACTERISTICS
9	PACKAGE OUTLINE
10	SOLDERING
10.1	Introduction
10.2	Reflow soldering
10.3	Wave soldering
10.4	Repairing soldered joints
11	DEFINITIONS
12	LIFE SUPPORT APPLICATIONS

DECT burst mode controller

PCD5043

1 FEATURES

- On-chip pre-programmed Communication Controller with embedded firmware for implementation of Traffic Bearer Control (TBC), MAC message handling, scanning, and control of the device's other functional units.
- Fixed Part (FP) modes
- TDMA frame (de)multiplexing
- Encryption
- Scrambling
- CRC generation and checking
- Beacon transmission control (by P00 packets)
- Switches up to 12 active speech channels from speech interface to 1152 kbits/s. radio interface, and vice versa
- Dual channel speech/data capability
- RSSI measurement, with on-chip 6-bits peak/hold detector
- Local call switching for up to 6 internal calls on RF side/local call switching on speech side
- Quality control report
- Digital Phase Locked Loop (DPLL)
- Synchronization (handset to active bearer, base station to cluster of RFPs)
- Seamless handover procedure
- Fast (hardware) and slow (software) mute function
- 1 kbyte extended RAM memory
- On-chip crystal oscillator (13.824 MHz)
- Programmable microcontroller clock frequency
- Programmable interrupts
- Watchdog with two programmable time-outs
- Low power consumption in standby mode
- Low supply voltage (2.7 to 5.5 V)
- SACMOS technology.

3 ORDERING INFORMATION

TYPE NUMBER	PACKAGE		
	NAME	DESCRIPTION	VERSION
PCD5043H	QFP64	plastic quad flat package; 64 leads (lead length 1.95 mm); body 14 × 20 × 2.8 mm	SOT319-2

2 GENERAL DESCRIPTION

The PCD5043 DECT Burst Mode Controller (BMC) is a custom IC that performs the DECT Physical Layer and MAC Layer time-critical functions, for use in DECT remote radio transceiver (PABX) products which comply with the following standards:

- DECT CI part 2: Physical layer (DE/RES 3001-2)
- DECT CI part 3 : Medium Access Control layer (DE/RES 3001-3)
- DECT CI part 7: Security features for DECT (DE/RES 3001-7)
- DECT CI part 9: Public Access Profile (DE/RES 3001-9).

The PCD5043 has interfaces to:

- Up to 4 ADPCM CODECs in a simple base station (with up to 4 analogue lines) without glue logic
- n x 64 kbits/s highway, where n = 1 to 32, for systems requiring more than 4 connections to the network
- A radio transceiver; the interface is fully decoded, and includes power-down signals
- An external microcontroller.

The PCD5043 is designed to be connected to an ADPCM CODEC (Philips' PCD5032, for example) and an 80C51-type microcontroller. Other microcontrollers (e.g. 68000) and CODECs can also be supported.

DECT burst mode controller

PCD5043

4 BLOCK DIAGRAM

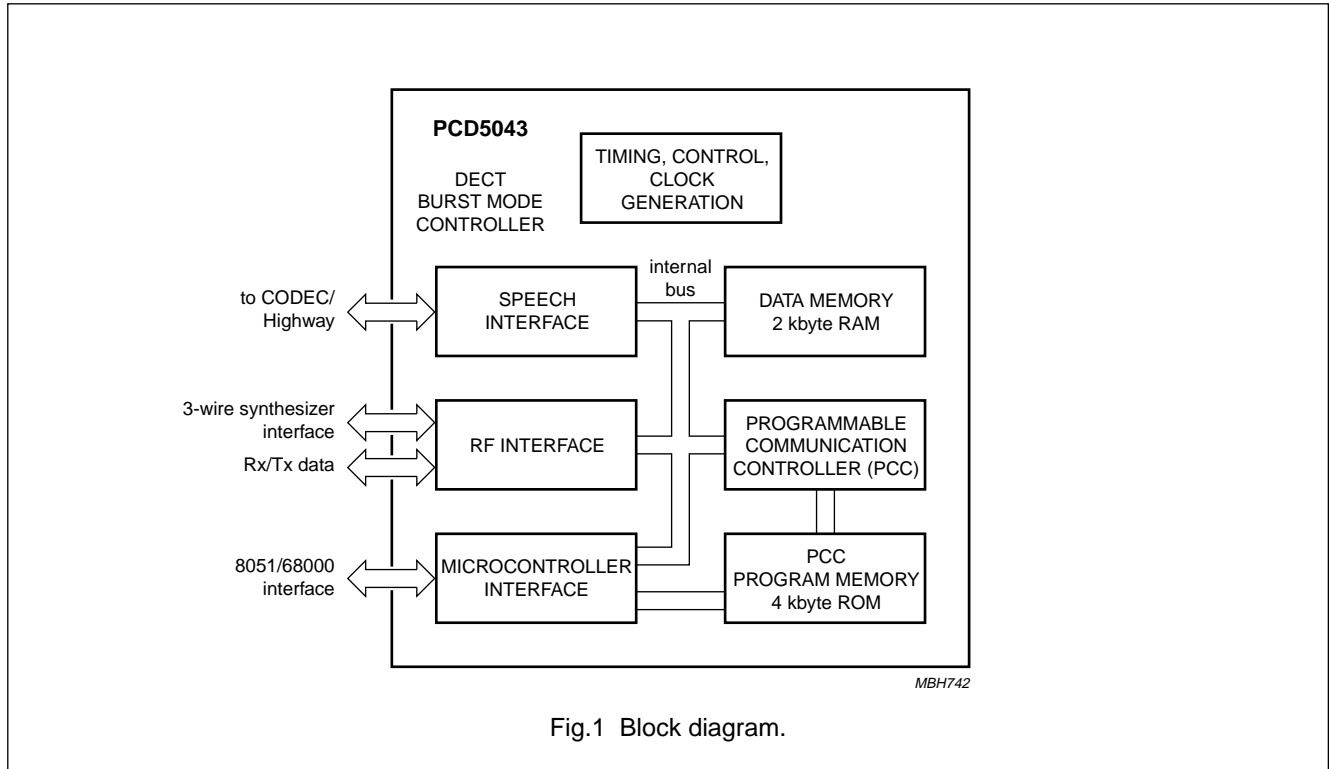

5 PINNING (see Fig.2)

SYMBOL	PIN	TYPE ⁽¹⁾	DESCRIPTION
AD0 to AD7	1 to 8	I/O	address/Data bus
ALE	9	I	address latch enable
\overline{CS}	10	I	chip select (active LOW)
A8 to A10	13 to 11	I	address bus
V _{DD1}	14	P	positive supply 1
PROC_CLK	15	O	microcontroller clock; programmable from $f_{CLK}/64$ to f_{CLK} , where f_{CLK} is the crystal oscillator frequency
V _{SS1}	16	P	negative supply 1
XTAL1	17	I	crystal oscillator input
XTAL2	18	O	crystal oscillator output
V _{SS2}	19	P	negative supply
RESET_OUT	20	O	watchdog timer output; intended to reset the external microcontroller when expired
\overline{RD}	21	I	read (active LOW)
\overline{WR}	22	I	write (active LOW)
\overline{RDY}	23	O	ready signal (active LOW), to initiate wait states in the microcontroller (open drain)
\overline{INT}	24	O	interrupt (active LOW)
CLK100	25	O	100 Hz frame timer

DECT burst mode controller

PCD5043

SYMBOL	PIN	TYPE ⁽¹⁾	DESCRIPTION
V _{SS3}	26	P	negative supply 3
DO	27	O	3-state data output on the speech interface
FS1	28	I/O	8 kHz framing signal to ADPCM CODEC 1 output, for simple base + handset, otherwise 8 kHz framing input
FS2	29	O	8 kHz framing signal to ADPCM CODEC 2 in the base station mode
DI	30	I	data input on the speech interface
DCK	31	O	simple base + handset; 1152 kHz data clock (output), otherwise 2048 kHz data clock (input) signal
CLK3	32	O	3.456 MHz clock (nominal value, used to adjust system timing)
ANT_SW	33	O	selects one of two antennas
T_ENABLE	34	O	Transmitter Enable (active LOW)
T_POWER_RMP	35	O	Transmitter Power Ramp control
RMT_STAT	36	I	serial 8-bit data can be read in for each slot; REMote radio
SYNTH_LOCK	37	I	lock indication from synthesizer
V _{SS4}	38	P	negative supply 4
REF_CLK	39	O	reference frequency for the synthesizer, i.e. the crystal oscillator clock f _{CLK}
V _{DD2}	40	P	positive supply 2
S_ENABLE	41	O	synthesizer enable
S_CLK	42	O	clock signal, to be used with S_DATA
S_DATA	43	O	serial data to the synthesizer
S_POWER_DWN	44	O	synthesizer power-down control
VCO_BND_SW	45	O	VCO bandswitch control signal
1200 HZ	46	O	control signal for dual synthesizer schemes
T_DATA	47	O	serial output data to transmitter
SET_OFF_IN	48	I	switches off the crystal oscillator, and prevents all RF signals from becoming active
TEST1	49	I	selects various test modes.; normal operation set to 0
RSSI_AN	50	I	analog signal (for basic DECT systems), peak signal strength measured after a lowpass filter
TEST2	51	I	selects various test modes; normal operation set to 0
TEST3	52	I	selects various test modes; normal operation set to 0
R_DATA	53	I	receive data
R_ENABLE	54	O	receiver enable (active LOW)
R_POWER_DWN	55	O	receiver power-down
SLICE_CTR	56	O	slice time constant control
V _{DD3}	57	P	positive supply 3
V _{SS5}	58	P	negative supply 5
V _{REF}	59	I	reference input for the A/D converter
V _{DD(RAM)}	60	P	power supply for data RAM
SYNCPORT	61	I/O	in the base station the signal is the SYNCPORT

DECT burst mode controller

PCD5043

SYMBOL	PIN	TYPE ⁽¹⁾	DESCRIPTION
RESET	62	I	BMC master reset signal
MEM_SEL	63	I	selects PCC program memory at microcontroller interface
EN_WATCHDOG	64	I	enable watchdog input; when HIGH, the watchdog timer of the BMC is enabled

Note

1. All signals which are input or I/O, and which can be floating, need to be pulled up to V_{DD} or down to V_{SS} in order to protect the device against cross-currents. Exceptions are VREF and RSSI_AN, which do not have to be protected.

DECT burst mode controller

PCD5043

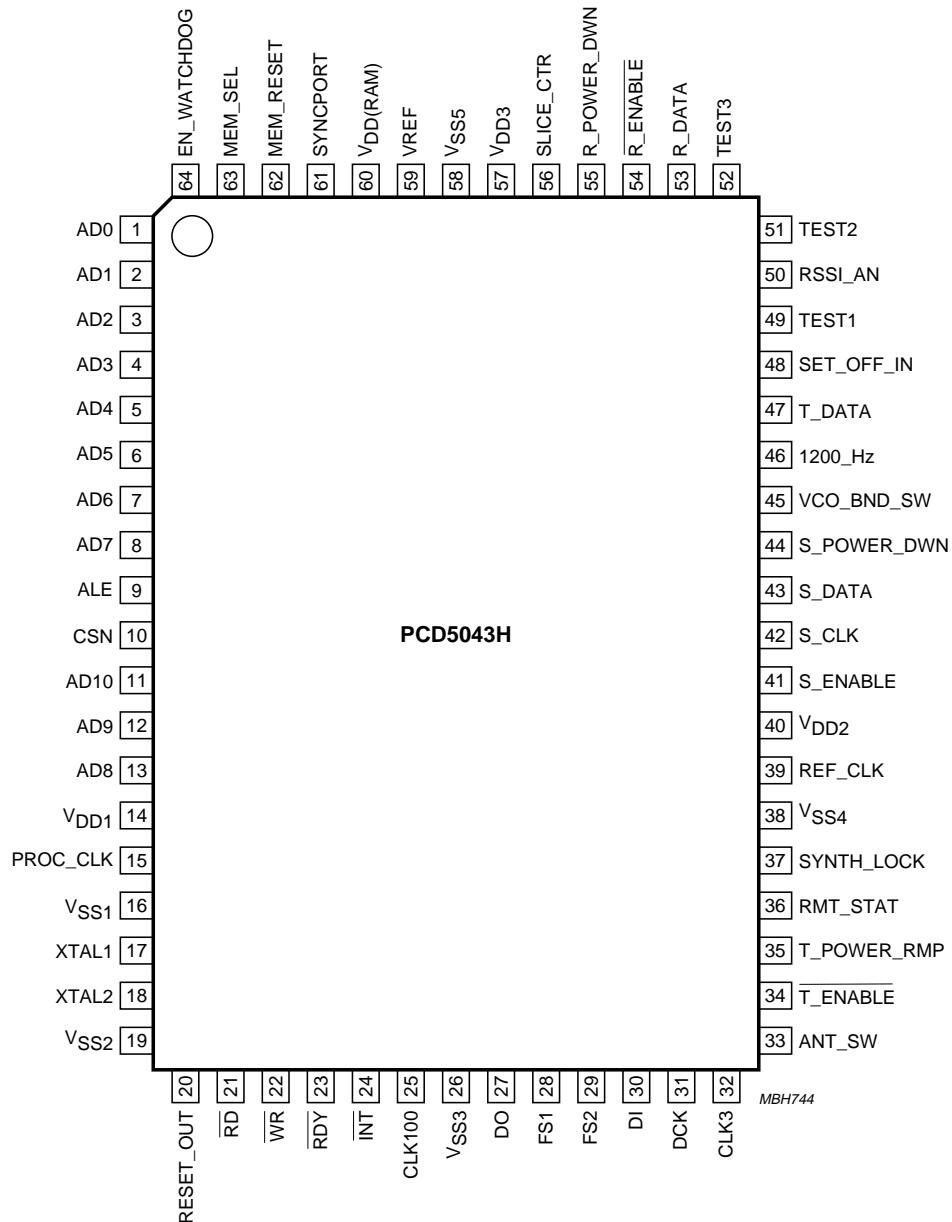

Fig.2 Pin configuration, PCD5043H.

DECT burst mode controller

PCD5043

6 FUNCTIONAL DESCRIPTION (see Fig.1)

The PCD5043 has dedicated hardware blocks containing logic for time-critical functions requiring bit or byte-time accuracy. Other functions requiring only slot-time accuracy are performed by software in the Preprogrammed Communication Controller (PCC). This approach offers maximum flexibility during prototyping.

6.1 Internal bus and data memory

6.1.1 INTERNAL BUS

The function of the internal bus is:

- To provide access for all functional blocks to the common data memory
- To provide access for the microcontroller-interface and the PCC to all other functional blocks.

All functional blocks (speech-interface, RF-interface, microcontroller-interface and PCC) can autonomously use the internal bus to communicate with the common data memory.

A bus controller is used to handle the bus priority mechanism. When several blocks request access simultaneously, the request with the highest priority is handled first.

6.1.2 DATA MEMORY

A large part of the data memory is used for the bit rate adaptation between the DECT radio interface and the speech interface. The data memory also acts as the main communication interface between the external microprocessor and the PCC.

6.2 Clock generation and correction (see Fig.3)

The device has an on-chip 13.824 MHz crystal oscillator. From this source, a few frequencies are derived for internal and external use. Frequencies generated for external use are:

- 13.824 MHz for the synthesizer reference (pin REF_CLK). This output is only provided if the synthesizer power-down control (output on pin S_POWER_DWN) is not selected.
- 0.144 to 13.824 MHz for the microcontroller clock (pin PROC_CLK)
- 3.456 MHz for the ADPCM codec (pin CLK3)
- 1200 Hz (pin 1200_HZ) for dual synthesizer switching
- 100 Hz (pin CLK100) indicates start of frame.

Nominally, the frequency on pin CLK3 is 3.456 MHz. This frequency is obtained by dividing the crystal frequency by 4. Sometimes, the crystal frequency will be divided by 3 or by 5, to synchronize the combination of the ADPCM codec and the device to an external source. External synchronization for base station applications is achieved as follows:

- **Master base station.** The master base station provides a 100 Hz signal to slave base stations on pin SYNCPORT. If the PCD5043 is connected to a digital interface (32-slot mode speech interface), the external synchronization will be done on the incoming 8 kHz signal. If it is connected to an analog line (12-slot mode speech interface), it will use its own crystal oscillator as reference.
- **Slave base station.** The slave base station will use the incoming SYNCPORT signal as synchronization reference.

6.3 Programmable communication controller and program memory

6.3.1 PCC

The PCC is a RISC-type controller and is used to control functions which are slot-time accurate. It is well suited for bit manipulation, and runs at a clock frequency of 6.912 MHz (equivalent to 3.4 Mips). After finishing a task, it switches to a power saving state, from which it returns after a pre-programmed time.

6.3.2 PCC FUNCTIONS

The most important functions of the PCC are to:

- Perform the appropriate actions on received messages: PMID and FMID checking, RFPI checking, TBC handling
- Prepare A-field messages for transmission
- Prepare the RF-interface for the coming slot
- Perform the procedures for RSSI and set-up scan, maintain scan counters and timers, assemble the RSSI field in the common data memory
- Filter events and indicate them to the microcontroller by interrupt.

DECT burst mode controller

PCD5043

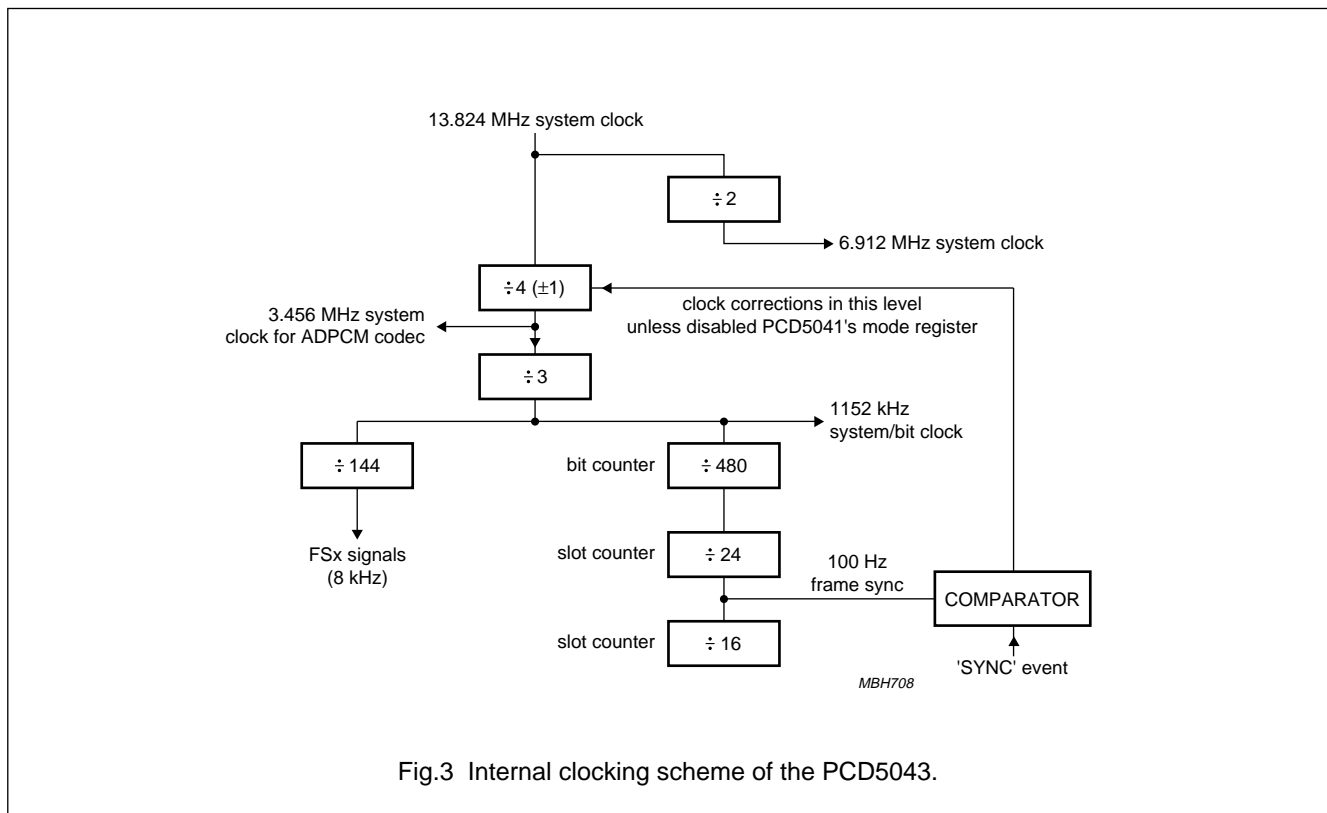

6.4 Speech interface

The speech interface block performs the following functions:

- Connection to a 1152 kbits/s interface in a handset and a simple base station in the so called '12 slot mode'
- Connection to a $n \times 64$ kbits/s interface in base stations in the so called '32 slot mode'
- Autonomous storing/fetching of ADPCM speech data in/from the PCD5043's common data memory, using internal addressing logic
- Muting of speech data
- Local call.

6.4.1 12-SLOT MODE

The 12-slot mode is selected if up to 4 ADPCM codecs are connected to the PCD5043, where the PCD5043 is the master of these codecs. In a handset, or in a simple base stations which is connected with up to 4 analog lines to the public network, the PCD5043 is master of the codecs. Each codec is connected with a separate framing reference signal (FS1 to FS4) to the PCD5043. In the QFP64 package, 2 framing signals FS1 and FS2 are available, whereas in the LQFP80 package 4 framing

signals can be used (FS1 to FS4). When more codecs are to be connected, the FS5 to FS12 signals have to be generated externally. When using the framing signals FS1 to FS4, no interface logic is required when using the PCD5032 ADPCM codec.

A speech-slot control table is used to determine where to store/fetch speech data for transmission and reception. The hardware speech-interface is capable of addressing the right speech buffer for the relevant speech slot, and will maintain a counter carrying the offset to the correct stored/fetched address.

6.4.2 32-SLOT MODE

The 32-slot mode is used to connect the PCD5043 to a digital interface with a data rate of $n \times 64$ kbits/s; where $n = 1$ to 32 is the number of speech slots. This equates to data rates from 64 kbits/s to 2048 kbits/s. Up to 12 of the 32 speech slots can be used simultaneously. The same kind of speech-slot control table used in the 12-slot mode is used for the 32-slot mode.

6.4.3 MUTING

Due to various reasons the quality of the incoming speech data may be degraded significantly. By muting the speech

DECT burst mode controller

PCD5043

data, these disturbances are not audible (or are less audible) to the user. The PCD5043 performs two types of muting:

- Fast muting
- Slow muting.

Fast muting, which is performed by the PCD5043 automatically, is nothing more than a repetition of the previously received frame (80 speech samples) to the ADPCM codec. It is issued if no Sync word was detected. Slow muting is issued by the microcontroller, after having detected a degradation of quality. A slow mute is implemented as a continuous '0000' nibble transmission to the ADPCM codec, until slow mute is released.

6.4.4 LOCAL CALL

A local call option is implemented, in order to loopback data from one codec to another codec, and vice versa, see Fig.4.

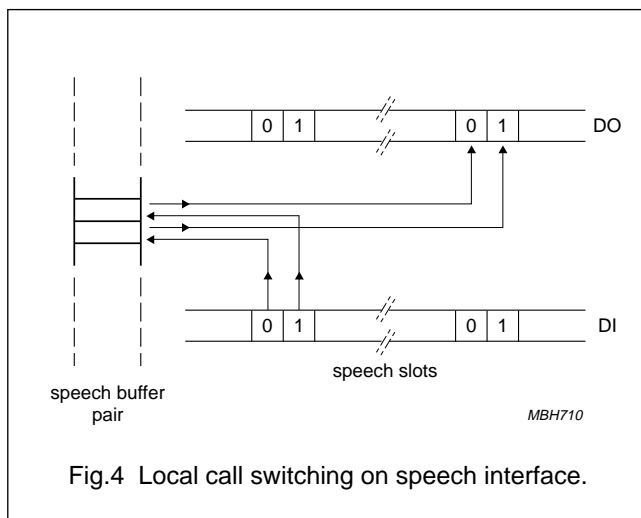

Fig.4 Local call switching on speech interface.

6.5 RF interface

Most of the functions performed by the RF interface are under control of the PCC. Specifically, the processing of non-speech data and the programming of functions and registers is done via the PCC.

6.5.1 SERIAL RECEIVER

The serial receiver processes the data, which comes from the RF section, and which is already filtered by the synchronization part. The data is latched, using the recovered data clock.

The serial receiver will collect the complete A-field and B-field and store it in the common data memory. Before the A-field is received, the A-field start address is programmed by the PCC. Upon reception of A-field nibbles, the address is updated by the serial receiver. Meanwhile, the PCC will program the B-field start address.

In Fig.5 the data flow in the serial receiver is shown. Note that almost no decoding of messages is required. Only the header of the A-field needs to be decoded to check if a ciphered message is being received or transmitted, which requires the ciphering to be switched on in the A-field also.

6.5.2 SERIAL TRANSMITTER

The serial transmitter performs the reverse of the receiver functions. Several blocks used in the receiver are also used in the transmitter. Amongst these are the CRC-generators, the scrambler, and the address registers. Figure 6 shows the serial transmitter structure.

By transmitting the X-CRC twice, the Z-field is transmitted. The handling of the address registers is the same for the transmitter. Transmission of the synchronization sequence (S-field) is done using the same method as the A-field and B-field. The S-field is stored in the common data memory and will be fetched by the transmitter, just before transmission.

Two additional functions are not shown in Fig.6:

- In the handset the data in the serial transmitter may be advanced by a programmable number of bit periods. This is done to compensate for the delay in the RF section
- The transmitted data can be inverted (using a switch in the PCD5043 mode register), in order to connect the PCD5043 to VCOs requiring negative modulation.

DECT burst mode controller

PCD5043

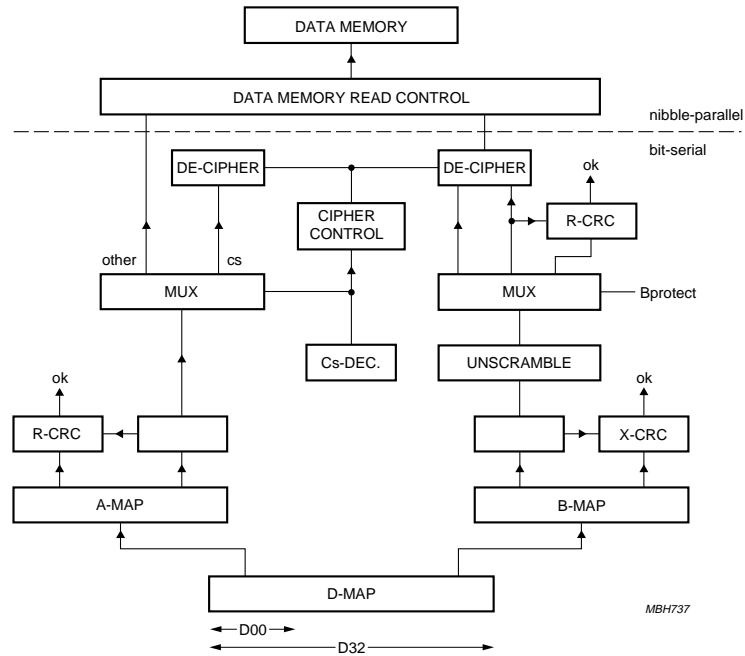

Fig.5 Serial receiver structure.

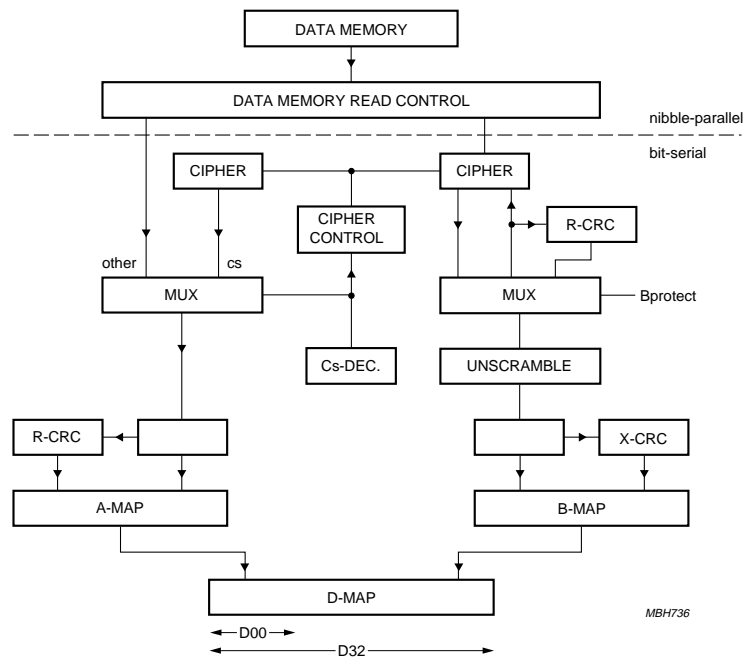

Fig.6 Serial transmitter structure.

DECT burst mode controller

PCD5043

6.5.3 SEAMLESS HANDOVER

Seamless handover guarantees that when speech information is switched from one slot to another, no speech samples are lost, added or displaced. Seamless handover is achieved in the RF interface by:

- Using a look-up table containing the correct start addresses of the B-fields in the data memory
- The RF receive and transmit blocks move data to/from the data memory block in 4-bit nibbles.

6.5.4 RF CONTROL SIGNALS

The timing of the control signals to the RF section is fixed, but such that an RF delay between 1.5 and 7 μ s can be tolerated. Only the transmitter ramp signal and the synthesizer enable are programmable within certain limits.

6.5.5 SYNTHESIZER PROGRAMMING

To program a synthesizer, a 3-wire serial interface is used. The signals on this interface are:

- S_ENABLE (enable)
- S_CLK (clock)
- S_DATA (data).

To program various types of synthesizers, a 3-byte shift register is present. Three data formats are supported: 8, 16 or 24 bit words can be selected. The transfer of data from a frequency table in the common data memory to the shift register is under control of the PCC.

6.5.6 RSSI MEASUREMENT

The RSSI measurement in the PCD5043 RF-interface block is done in 3 parts: a peak/hold detector, a 6-bit A/D converter, and an RSSI control unit, which controls the peak/hold detector and the A/D converter. Once per slot time, a sample is fetched by the PCC and saved in the appropriate area of the common data memory.

If the radio receiver is active in a particular time slot, the RSSI value will automatically be measured in that slot. Adjustment to the RSSI_AN input level can be made with VREF.

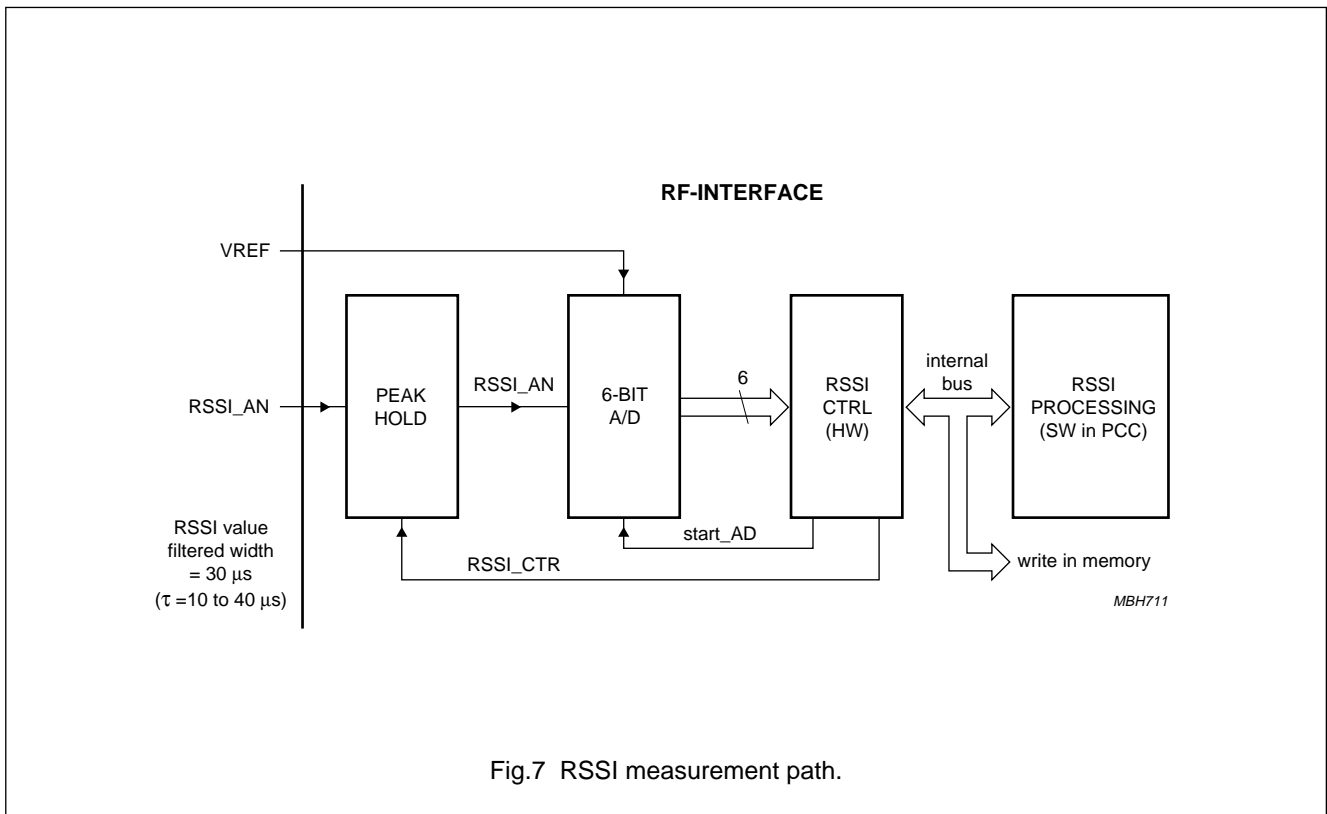

DECT burst mode controller

PCD5043

6.5.7 LOCAL CALL SWITCHING (see Fig.8)

The PCD5043 provides a local call switching function in the base station. It will store incoming speech nibbles in the common data memory, in the area reserved for that particular receive slot. Then, during the transmit phase, it passes the start pointer of the same data memory area to the transmit block. Thus, the speech data is echoed to the other user. To handle quality degradation for local calls, a mute can be performed at the RF side of the speech buffer.

6.5.8 DATA SYNCHRONIZATION (see Fig.9)

The data synchronization is done in 2 phases:

- Bit synchronization
- Sync word detection.

Bit synchronization is done using a Digital PLL (DPLL), with an oversampling factor of 12, i.e. the DPLL is running at 12 times the data rate. The output from the DPLL is a receive clock signal (RxC), which acts as the enable for a 20-bit shift register.

Sync word detection is achieved by checking the incoming data pattern with the expected synchronization field pattern, using a correlator.

The correlator has a programmable threshold, so it can accept bit errors in the sync field pattern up to the threshold level. Furthermore, the correlator window is programmable. This means that 'SlotSync', which indicates the slot synchronization event, can be detected only during a certain period (the time window).

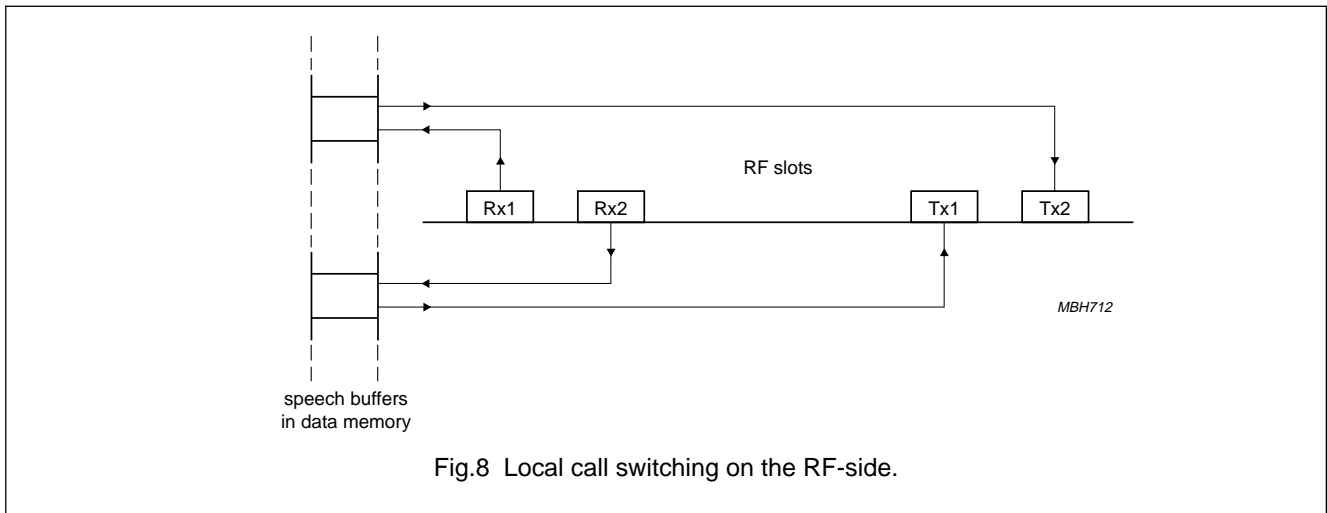

Fig.8 Local call switching on the RF-side.

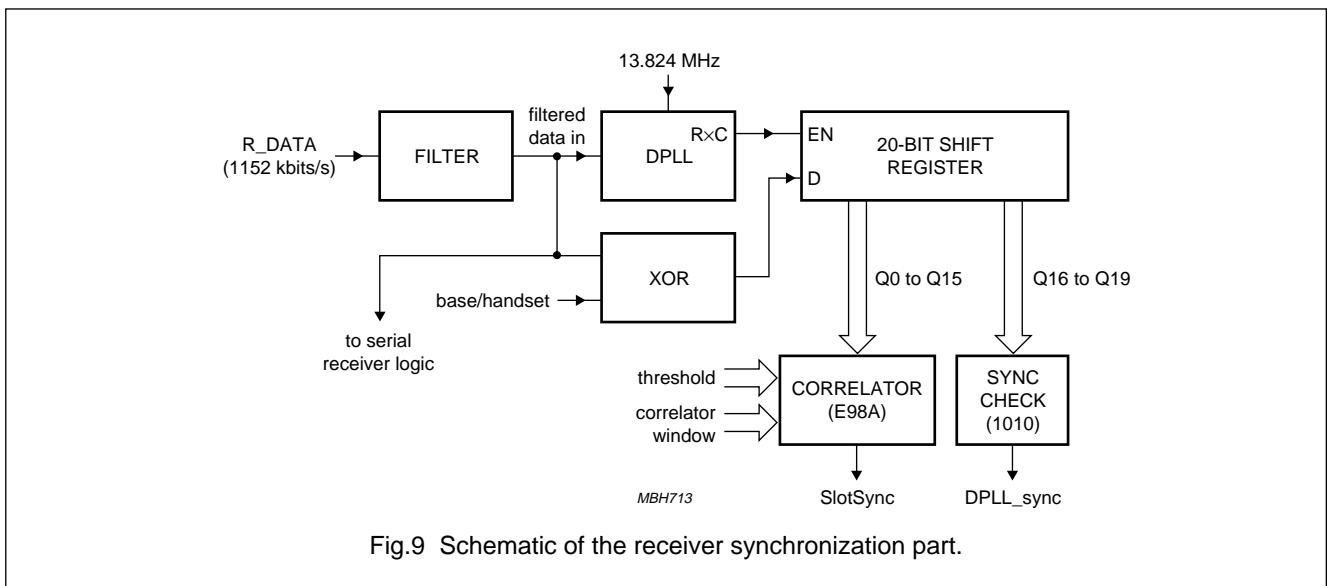

Fig.9 Schematic of the receiver synchronization part.

DECT burst mode controller

PCD5043

The 'DPLL_sync' indication should only be used, when 'SlotSync' is active. It indicates that the last 4 bits of the pre-amble field (the training sequence) are received correctly, and thus indicates that the DPLL was in lock (synchronized) in time. If the 'SlotSync' is active, and the 'DPLL_sync' is not, then a sliding interferer might have been detected.

If 'SlotSync' is not detected, effectively no data is received in that slot. This implies a 'fast mute' because speech data received in the previous frame is not destroyed.

6.5.9 CIPHERING MACHINE

The description of the cipher machine is subject to confidentiality. The specification of its algorithms are delivered by ETSI under the terms of a Non-Disclosure Agreement.

The cipher machine is under control of the TBC, which is implemented in the PCC. The cipher machine generates 2 fields of ciphering bits:

- A_cipher (40 bits) for A-field messages (ciphers tail only)
- B_cipher (320 bits) for speech in B-field.

The transmitted ciphered bits are then:

- A_ciphered: = A XOR A_cipher
- B_ciphered: = B XOR B_cipher.

On reception by the peer end point, deciphering consists of the same operation thanks to the synchronous generation of A_cipher and B_cipher.

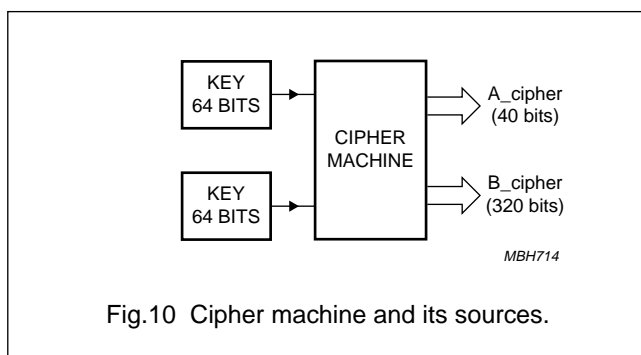

The cipher machine is time-multiplexed on a slot basis. Initially, the Initialisation Vector (IV) and the key must be loaded into the cipher machine. Transfer of the IV and key from the common data area to the cipher machine is done automatically by the cipher machine. The contents of the memory space where IV and key are found, are the

responsibility of the PCC, and the external microprocessor.

6.6 Microcontroller Interface

6.6.1 FUNCTION OF THE MICROCONTROLLER INTERFACE

The microcontroller Interface will provide the following services.

- Direct interface to processors which have an INTEL-8051 compatible interface
- General interface to processors that can handle 'wait states' e.g. 68000-family; in this case glue logic is required
- Processor clock signal of which the frequency is programmable in order to adjust instantaneously processor performance to processor work load
- A programmable interrupt register
- A watchdog timer with time-out periods of 1.25 or 82 seconds, depending on the programming.

The microcontroller can address the PCD5043 as any other RAM memory connected to the microcontroller bus. By writing the 'Interface-Mode Register', the microcontroller can select the interface mode and its own clock frequency.

6.6.2 MICROCONTROLLER INTERRUPTS

The function of microcontroller Interrupts is to make optimal use of the microcontroller's processing power, and to achieve optimal cooperation between time-critical tasks and less time-critical tasks both executed in software. Three registers are available to handle interrupts. These are:

- Interrupt Event Register
- Interrupt Enable Register
- Interrupt Reset Register.

These registers are to be regarded together. Corresponding bits in these registers relate to one and the same event. Bits in the Interrupt Event Register are set by the PCC and are to be reset by the external processor by writing '1's in the corresponding bits in the Interrupt Reset Register. The mask in the Interrupt Enable Register enables the interrupt if corresponding events do occur.

DECT burst mode controller

PCD5043

6.6.3 WATCHDOG

The PCD5043 is equipped with a watchdog timer, which generates a reset towards an external device (e.g. a μC) after time-out. Two (fixed) time-out periods can be programmed; 1.25 s and 82 s. The watchdog function can be disabled by using the EN_WATCHDOG input pin.

6.6.4 POWER-DOWN

The PCC may switch off the 6.912 MHz internal clock, to enter a power saving mode. All blocks, running on this clock are then switched off (i.e. RF-interface, cipher block, speech interface, PCC). This is called the power-down state, and is only used in the handset mode.

The 13.824 MHz clock is never switched off. The Timing Control, microcontroller interface, and Bus Controller keep running, in order to remain synchronous with a base station, and to keep the wake-up circuitry active. During power-down the external microcontroller has still access to the common data area.

6.7 Survey of registers

For a survey of all addresses occupied refer to Tables 1 and 2. Some of the address locations are used differently for read and write. The addresses 000 to 7DF are occupied by RAM memory, while the upper 32 bytes are assigned to the hardware registers. A part of the RAM memory is allocated for use by the RF block, cipher block, and the speech interface.

Table 1 Hardware register addresses

ADDRESS	WRITE	READ
7E0	–	–
7E1	S-DATA1	–
7E2	S-DATA2	–
7E3	S-DATA3	RMT-STAT
7E4	–	RF-STATUS
7E5	B-field-shift	–
7E6	B-field-loc.	–
7E7	A-field-loc.	–
7E8	window-wide-off	–
7E9	window-wide-on	–
7EA	window-narrow-off	–
7EB	window-narrow-on	–
7EC	T-power-rmp-on	–
7ED	synth-off	–
7EE	RF-control-port	sync-status
7EF	slot-cnt-off	slot-counter-copy
7F0	frame-cnt-ref	RSSI
7F1	sync-ref-preset	bit-counter-copy1
7F2	bit-counter-preset	bit-counter-copy2
7F3	frame-counter	frame-counter
7F4	slot-counter	slot-counter
7F5	sync-control	sync-control
7F6	BMC-mode	BMC-mode
7F7	correlator-threshold	measure
7F8	watchdog-1	–
7F9	watchdog-2	–
7FA	–	–
7FB	–	–
7FC	interrupt-event	interrupt-event
7FD	interrupt-enable	interrupt-enable
7FE	interrupt-reset	–
7FF	controller mode	controller mode

DECT burst mode controller

PCD5043

Table 2 Fixed RAM locations

ADDRESS	ENTRY
740 to 747	cipher key vector #0
748 to 74F	cipher key vector #1
750 to 757	cipher key vector #2
758 to 75F	cipher key vector #3
760 to 767	cipher key vector #4
768 to 76F	cipher key vector #5
770 to 777	cipher key vector #6
778 to 77F	cipher key vector #7
780 to 787	cipher key vector #8
788 to 78F	cipher key vector #9
790 to 797	cipher key vector #10
798 to 79F	cipher key vector #11
7A0 to 7A7	cipher init vector
7A8 to 7AA	not used
7AB	XZ field buffer
7AC to 7AF	S-field buffer
7B0 to 7BB	cipher-slot-control-table
7BC to 7BF	not used
7C0 to 7DF	speech-slot-control-table

7 LIMITING VALUES

In accordance with the Absolute Maximum Rating System (IEC 134).

SYMBOL	PARAMETER	MIN.	MAX.	UNIT
V_{DD}	supply voltage	-0.5	+6.5	V
V_i	all input voltages	-0.5	$V_{DD} + 0.5$	V
I_i	DC input current	-10	+10	mA
I_o	DC output current	-10	+10	mA
P_{tot}	total power dissipation	-	+500	mW
P_o	power dissipation per output	-	30	mW
I_{DD}	supply current	-100	+130	mA
I_{SS}	ground current	-100	+130	mA
T_{stg}	storage temperature range	-55	+100	°C
T_j	operating junction temperature	-	90	°C

DECT burst mode controller

PCD5043

8 CHARACTERISTICS

SYMBOL	PARAMETER	CONDITIONS	MIN.	TYP.	MAX.	UNIT
T_{amb}	operating ambient temperature		-25	-	+70	°C
V_{DD}	supply voltage		2.7	-	5.5	V
$V_{DD(ret)}$	RAM retention voltage		1.0	-	V_{DD}	V
I_{DD}	operating supply current	note 1	-	6	12	mA
$I_{DD(stb)}$	standby supply current	note 2	-	1	3	mA
	clock input duty cycle	All inputs LOW except WRN; XTAL1 running at 14 MHz	45	-	55	%
Digital I/O						
V_{IL}	LOW level input voltage		0	-	$0.3V_{DD}$	V
V_{OL}	LOW level output voltage		0	-	$0.3V_{DD}$	V
V_{IH}	HIGH level input voltage		$0.7V_{DD}$	-	V_{DD}	V
V_{OH}	HIGH level output voltage		$0.7V_{DD}$	-	V_{DD}	V
I_{LI}	input leakage current				1.0	µA
$I_{O(source)}$	output source current	$V_{DD} = 3.6\text{ V};$ $0.4\text{ V} \leq V_O \leq V_{DD} - 0.4\text{ V}$	2.0	5.0	-	mA
$I_{O(sink)}$	output sink current	$V_{DD} = 3.6\text{ V};$ $0.4\text{ V} \leq V_O \leq V_{DD} - 0.4\text{ V}$	2.0	5.0	-	mA
$I_{RDYN(sink)}$	RDYN output sink current	$V_{DD} = 3.6\text{ V}; V_O = 0.4\text{ V}$	2.0	5.0	-	mA
		$V_{DD} = 5.0\text{ V}; V_O = 0.4\text{ V}$	-	6.0	-	mA
f_{DCK}	DCK input frequency	$n = 1\text{ to }32$	-	$n \times 64$	-	kHz
f_{FS1}	FS1 input frequency		-	8	-	kHz
Oscillator (inputs XTAL1 and XTAL2)						
g_m	transconductance	$V_{DD} = 2.7\text{ V}$	0.6	-	-	mS
		$V_{DD} = 3.6\text{ V}$	-	1.6	-	mS
R_F	feedback resistance		200	500		kΩ
RSSI Peak detector (6-bit linear A-D converter, for RSSI measurement on input RSSI_AN)						
$V_{i(RSSI_AN)}$	input level		0	-	V_{DD}	V
$V_{conv(RSSI_AN)}$	voltage conversion range		0	-	V_{REF}	V
$V_{i(VREF)}$	V_{REF} input voltage		1.0	3.0	V_{DD}	V
$Z_{i(VREF)}$	V_{REF} input impedance	during power-down high impedance	-	50	-	kΩ
t_{conv}	conversion time		18.4	-	-	µs
	integral non-linearity		-	-	4	LSB
	differential non-linearity	note 3	-	0.2	1.5	LSB
$Z_{i(RSSI_AN)}$	input impedance RSSI_AN		-	1	-	MΩ

Notes to the characteristics

- $V_{DD} = 3.0\text{ V}; f_{clk} = 13.824\text{ MHz}$; no external load; one speech link active (under typical conditions).
- $V_{DD} = 3.0\text{ V}; f_{clk} = 13.824\text{ MHz}$; no external load; after reset.
- Maximum differential non-linearity at supply voltage 5.5 V and $V_{REF} = 1\text{ V}$.

DECT burst mode controller

PCD5043

9 PACKAGE OUTLINE

QFP64: plastic quad flat package;
64 leads (lead length 1.95 mm); body 14 x 20 x 2.7 mm; high stand-off height

SOT319-1

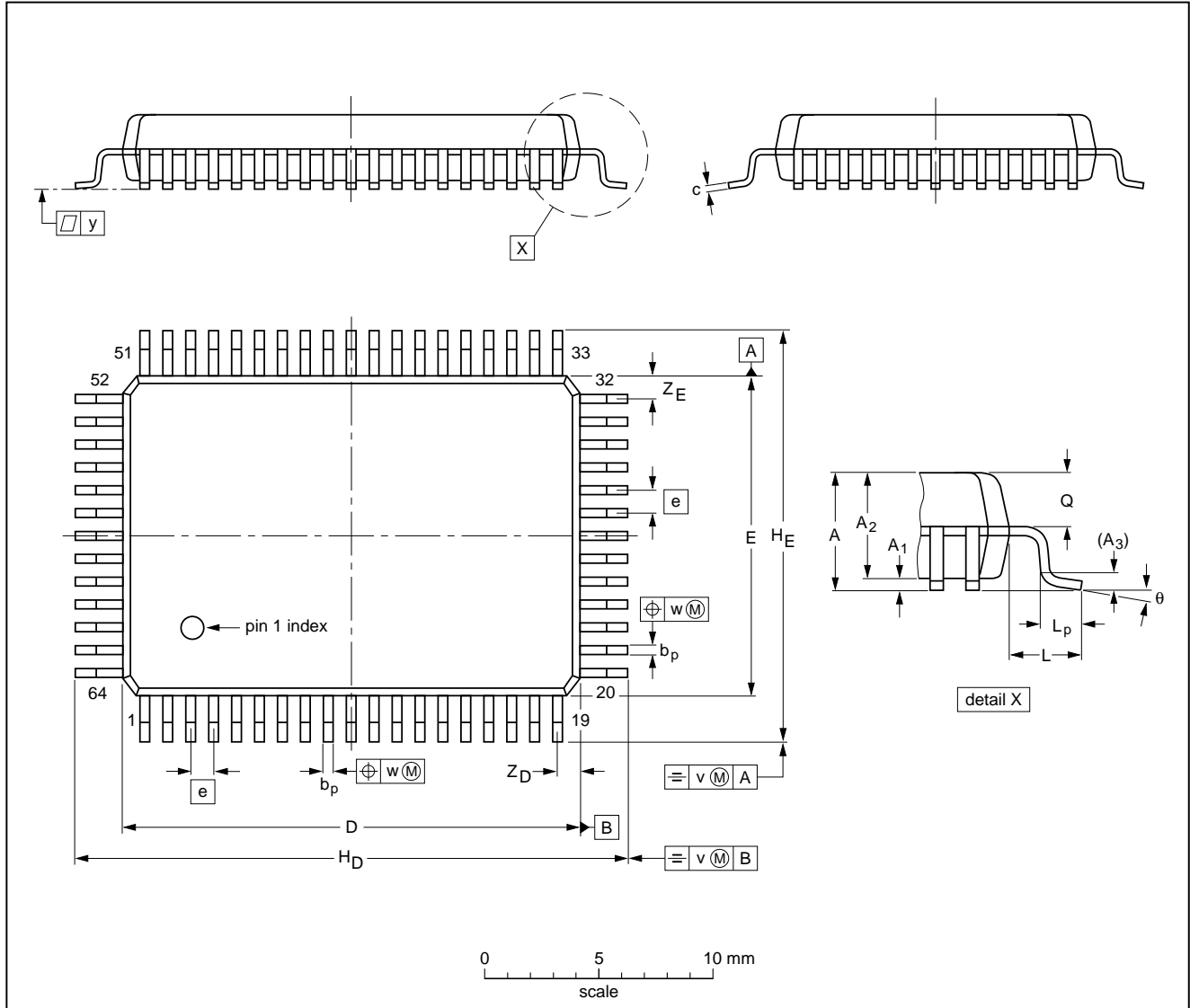

DIMENSIONS (mm are the original dimensions)

UNIT	A max.	A ₁	A ₂	A ₃	b _p	c	D ⁽¹⁾	E ⁽¹⁾	e	H _D	H _E	L	L _p	Q	v	w	y	Z _D ⁽¹⁾	Z _E ⁽¹⁾	θ
mm	3.3	0.36 0.10	2.87 2.57	0.25	0.50 0.35	0.25 0.13	20.1 19.9	14.1 13.9	1	24.2 23.6	18.2 17.6	1.95	1.0 0.6	1.43 1.23	0.2	0.2	0.1	1.2 0.8	1.2 0.8	7° 0°

Note

1. Plastic or metal protrusions of 0.25 mm maximum per side are not included.

OUTLINE VERSION	REFERENCES				EUROPEAN PROJECTION	ISSUE DATE
	IEC	JEDEC	EIAJ			
SOT319-1						92-11-17 95-02-04

DECT burst mode controller

PCD5043

10 SOLDERING

10.1 Introduction

There is no soldering method that is ideal for all IC packages. Wave soldering is often preferred when through-hole and surface mounted components are mixed on one printed-circuit board. However, wave soldering is not always suitable for surface mounted ICs, or for printed-circuits with high population densities. In these situations reflow soldering is often used.

This text gives a very brief insight to a complex technology. A more in-depth account of soldering ICs can be found in our *"IC Package Databook"* (order code 9398 652 90011).

10.2 Reflow soldering

Reflow soldering techniques are suitable for all QFP packages.

The choice of heating method may be influenced by larger plastic QFP packages (44 leads, or more). If infrared or vapour phase heating is used and the large packages are not absolutely dry (less than 0.1% moisture content by weight), vaporization of the small amount of moisture in them can cause cracking of the plastic body. For more information, refer to the Drypack chapter in our *"Quality Reference Handbook"* (order code 9397 750 00192).

Reflow soldering requires solder paste (a suspension of fine solder particles, flux and binding agent) to be applied to the printed-circuit board by screen printing, stencilling or pressure-syringe dispensing before package placement.

Several techniques exist for reflowing; for example, thermal conduction by heated belt. Dwell times vary between 50 and 300 seconds depending on heating method. Typical reflow temperatures range from 215 to 250 °C.

Preheating is necessary to dry the paste and evaporate the binding agent. Preheating duration: 45 minutes at 45 °C.

10.3 Wave soldering

Wave soldering is **not** recommended for QFP packages. This is because of the likelihood of solder bridging due to closely-spaced leads and the possibility of incomplete solder penetration in multi-lead devices.

If wave soldering cannot be avoided, the following conditions must be observed:

- **A double-wave (a turbulent wave with high upward pressure followed by a smooth laminar wave) soldering technique should be used.**
- **The footprint must be at an angle of 45° to the board direction and must incorporate solder thieves downstream and at the side corners.**

Even with these conditions, do not consider wave soldering the following packages: QFP52 (SOT379-1), QFP100 (SOT317-1), QFP100 (SOT317-2), QFP100 (SOT382-1) or QFP160 (SOT322-1).

During placement and before soldering, the package must be fixed with a droplet of adhesive. The adhesive can be applied by screen printing, pin transfer or syringe dispensing. The package can be soldered after the adhesive is cured.

Maximum permissible solder temperature is 260 °C, and maximum duration of package immersion in solder is 10 seconds, if cooled to less than 150 °C within 6 seconds. Typical dwell time is 4 seconds at 250 °C.

A mildly-activated flux will eliminate the need for removal of corrosive residues in most applications.

10.4 Repairing soldered joints

Fix the component by first soldering two diagonally-opposite end leads. Use only a low voltage soldering iron (less than 24 V) applied to the flat part of the lead. Contact time must be limited to 10 seconds at up to 300 °C. When using a dedicated tool, all other leads can be soldered in one operation within 2 to 5 seconds between 270 and 320 °C.

DECT burst mode controller

PCD5043

11 DEFINITIONS

Data sheet status	
Objective specification	This data sheet contains target or goal specifications for product development.
Preliminary specification	This data sheet contains preliminary data; supplementary data may be published later.
Product specification	This data sheet contains final product specifications.
Limiting values	
Limiting values given are in accordance with the Absolute Maximum Rating System (IEC 134). Stress above one or more of the limiting values may cause permanent damage to the device. These are stress ratings only and operation of the device at these or at any other conditions above those given in the Characteristics sections of the specification is not implied. Exposure to limiting values for extended periods may affect device reliability.	
Application information	
Where application information is given, it is advisory and does not form part of the specification.	

12 LIFE SUPPORT APPLICATIONS

These products are not designed for use in life support appliances, devices, or systems where malfunction of these products can reasonably be expected to result in personal injury. Philips customers using or selling these products for use in such applications do so at their own risk and agree to fully indemnify Philips for any damages resulting from such improper use or sale.

DECT burst mode controller

PCD5043

NOTES

DECT burst mode controller

PCD5043

NOTES

DECT burst mode controller

PCD5043

NOTES

Philips Semiconductors – a worldwide company

Argentina: see South America

Australia: 34 Waterloo Road, NORTH RYDE, NSW 2113,
Tel. +61 2 9805 4455, Fax. +61 2 9805 4466

Austria: Computerstr. 6, A-1101 WIEN, P.O. Box 213,
Tel. +43 1 60 101, Fax. +43 1 60 101 1210

Belarus: Hotel Minsk Business Center, Bld. 3, r. 1211, Volodarski Str. 6,
220050 MINSK, Tel. +375 172 200 733, Fax. +375 172 200 773

Belgium: see The Netherlands

Brazil: see South America

Bulgaria: Philips Bulgaria Ltd., Energoproject, 15th floor,
51 James Bourchier Blvd., 1407 SOFIA,
Tel. +359 2 689 211, Fax. +359 2 689 102

Canada: PHILIPS SEMICONDUCTORS/COMPONENTS,
Tel. +1 800 234 7381

China/Hong Kong: 501 Hong Kong Industrial Technology Centre,
72 Tat Chee Avenue, Kowloon Tong, HONG KONG,
Tel. +852 2319 7888, Fax. +852 2319 7700

Colombia: see South America

Czech Republic: see Austria

Denmark: Prags Boulevard 80, PB 1919, DK-2300 COPENHAGEN S,
Tel. +45 32 88 2636, Fax. +45 31 57 1949

Finland: Sinikalliontie 3, FIN-02630 ESPOO,
Tel. +358 9 615800, Fax. +358 9 61580/xxx

France: 4 Rue du Port-aux-Vins, BP317, 92156 SURESNES Cedex,
Tel. +33 1 40 99 6161, Fax. +33 1 40 99 6427

Germany: Hammerbrookstraße 69, D-20097 HAMBURG,
Tel. +49 40 23 53 60, Fax. +49 40 23 536 300

Greece: No. 15, 25th March Street, GR 17778 TAVROS/ATHENS,
Tel. +30 1 4894 339/239, Fax. +30 1 4814 240

Hungary: see Austria

India: Philips INDIA Ltd, Shivsagar Estate, A Block, Dr. Annie Besant Rd.
Worli, MUMBAI 400 018, Tel. +91 22 4938 541, Fax. +91 22 4938 722

Indonesia: see Singapore

Ireland: Newstead, Clonskeagh, DUBLIN 14,
Tel. +353 1 7640 000, Fax. +353 1 7640 200

Israel: RAPAC Electronics, 7 Kehilat Saloniki St, TEL AVIV 61180,
Tel. +972 3 645 0444, Fax. +972 3 649 1007

Italy: PHILIPS SEMICONDUCTORS, Piazza IV Novembre 3,
20124 MILANO, Tel. +39 2 6752 2531, Fax. +39 2 6752 2557

Japan: Philips Bldg 13-37, Kohnan 2-chome, Minato-ku, TOKYO 108,
Tel. +81 3 3740 5130, Fax. +81 3 3740 5077

Korea: Philips House, 260-199 Itaewon-dong, Yongsan-ku, SEOUL,
Tel. +82 2 709 1412, Fax. +82 2 709 1415

Malaysia: No. 76 Jalan Universiti, 46200 PETALING JAYA, SELANGOR,
Tel. +60 3 750 5214, Fax. +60 3 757 4880

Mexico: 5900 Gateway East, Suite 200, EL PASO, TEXAS 79905,
Tel. +9-5 800 234 7381

Middle East: see Italy

Netherlands: Postbus 90050, 5600 PB EINDHOVEN, Bldg. VB,
Tel. +31 40 27 82785, Fax. +31 40 27 88399

New Zealand: 2 Wagener Place, C.P.O. Box 1041, AUCKLAND,
Tel. +64 9 849 4160, Fax. +64 9 849 7811

Norway: Box 1, Manglerud 0612, OSLO,
Tel. +47 22 74 8000, Fax. +47 22 74 8341

Philippines: Philips Semiconductors Philippines Inc.,
106 Valero St. Salcedo Village, P.O. Box 2108 MCC, MAKATI,
Metro MANILA, Tel. +63 2 816 6380, Fax. +63 2 817 3474

Poland: Ul. Lukiska 10, PL 04-123 WARSZAWA,
Tel. +48 22 612 2831, Fax. +48 22 612 2327

Portugal: see Spain

Romania: see Italy

Russia: Philips Russia, Ul. Usatcheva 35A, 119048 MOSCOW,
Tel. +7 095 247 9145, Fax. +7 095 247 9144

Singapore: Lorong 1, Toa Payoh, SINGAPORE 1231,
Tel. +65 350 2538, Fax. +65 251 6500

Slovakia: see Austria

Slovenia: see Italy

South Africa: S.A. PHILIPS Pty Ltd., 195-215 Main Road Martindale,
2092 JOHANNESBURG, P.O. Box 7430 Johannesburg 2000,
Tel. +27 11 470 5911, Fax. +27 11 470 5494

South America: Rua do Rocio 220, 5th floor, Suite 51,
04552-903 São Paulo, SÃO PAULO - SP, Brazil,
Tel. +55 11 821 2333, Fax. +55 11 829 1849

Spain: Balmes 22, 08007 BARCELONA,
Tel. +34 3 301 6312, Fax. +34 3 301 4107

Sweden: Kottbygatan 7, Akalla, S-16485 STOCKHOLM,
Tel. +46 8 632 2000, Fax. +46 8 632 2745

Switzerland: Allmendstrasse 140, CH-8027 ZÜRICH,
Tel. +41 1 488 2686, Fax. +41 1 481 7730

Taiwan: PHILIPS TAIWAN Ltd., 23-30F, 66,
Chung Hsiao West Road, Sec. 1, P.O. Box 22978,
TAIPEI 100, Tel. +886 2 382 4443, Fax. +886 2 382 4444

Thailand: PHILIPS ELECTRONICS (THAILAND) Ltd.,
209/2 Sanpavuth-Bangna Road Prakanong, BANGKOK 10260,
Tel. +66 2 745 4090, Fax. +66 2 398 0793

Turkey: Talatpasa Cad. No. 5, 80640 GÜLTEPE/ISTANBUL,
Tel. +90 212 279 2770, Fax. +90 212 282 6707

Ukraine: PHILIPS UKRAINE, 4 Patrice Lumumba str., Building B, Floor 7,
252042 KIEV, Tel. +380 44 264 2776, Fax. +380 44 268 0461

United Kingdom: Philips Semiconductors Ltd., 276 Bath Road, Hayes,
MIDDLESEX UB3 5BX, Tel. +44 181 730 5000, Fax. +44 181 754 8421

United States: 811 East Arques Avenue, SUNNYVALE, CA 94088-3409,
Tel. +1 800 234 7381

Uruguay: see South America

Vietnam: see Singapore

Yugoslavia: PHILIPS, Trg N. Pasica 5/v, 11000 BEOGRAD,
Tel. +381 11 625 344, Fax. +381 11 635 777

For all other countries apply to: Philips Semiconductors, Marketing & Sales Communications,
Building BE-p, P.O. Box 218, 5600 MD EINDHOVEN, The Netherlands, Fax. +31 40 27 24825

Internet: <http://www.semiconductors.philips.com>

© Philips Electronics N.V. 1996

SCA52

All rights are reserved. Reproduction in whole or in part is prohibited without the prior written consent of the copyright owner.

The information presented in this document does not form part of any quotation or contract, is believed to be accurate and reliable and may be changed without notice. No liability will be accepted by the publisher for any consequence of its use. Publication thereof does not convey nor imply any license under patent- or other industrial or intellectual property rights.

Printed in The Netherlands

647021/00/01/pp24

Date of release: 1996 Oct 31

Document order number: 9397 750 01293

Let's make things better.

Philips
Semiconductors



PHILIPS