

OPTIDRIVE™

User Guide

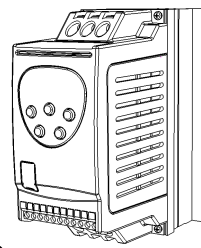

All rights reserved. No part of this User Guide may be reproduced or transmitted in any form or by any means, electrical or mechanical including photocopying, recording or by any information storage or retrieval system without permission in writing from the publisher.

Copyright Invertek Drives Ltd © 1998

The manufacturer accepts no liability for any consequences resulting from inappropriate, negligent or incorrect installation, or adjustment of the optional operating parameters of the drive or from mismatching of the drive to the motor.

The contents of this User Guide are believed to be correct at the time of printing. In the interest of a commitment to a policy of continuous improvement, the manufacturer reserves the right to change the specification of the product or its performance or the contents of the User Guide without notice.

SAFETY

This variable speed drive product (Optidrive) is intended for professional incorporation into complete equipment or systems. If installed incorrectly it may present a safety hazard. The Optidrive uses high voltages and currents, carries a high level of stored electrical energy, and is used to control mechanical plant that may cause injury. Close attention is required to system design and electrical installation to avoid hazards in either normal operation or in the event of equipment malfunction.

System design, installation, commissioning and maintenance must be carried out only by personnel who have the necessary training and experience. They must read carefully this safety information and the instructions in this Guide and follow all information regarding transport, storage, installation and use of the Optidrive, including the specified environmental limitations.

Please read the IMPORTANT SAFETY INFORMATION below, and all Warning and Caution boxes elsewhere.

SAFETY NOTICES

WARNING is given where there is a hazard that could lead to injury or death of personnel.

CAUTION is given where there is a hazard that could lead to damage to equipment.

IMPORTANT SAFETY INFORMATION

Safety of machinery, and safety-critical applications

Optidrive hardware and software are designed and tested to a high standard and failures are unlikely.

WARNING The level of integrity offered by the Optidrive control functions – for example stop/start, forward/reverse and maximum speed, is not sufficient for use in safety-critical applications without independent channels of protection. All applications where malfunction could cause injury or loss of life must be subject to a risk assessment and further protection provided where needed. Within the European Union, all machinery in which this product is used must comply with Directive 89/392/EEC, Safety of Machinery. In particular, the electrical equipment should comply with EN60204-1.

Electromagnetic Compatibility (EMC)

Optidrive is designed to high standards of EMC. EMC data is provided in a separate EMC Data Sheet, available on request. Under extreme conditions, the product might cause or suffer disturbance due to electromagnetic interaction with other equipment. It is the responsibility of the installer to ensure that the equipment or system into which the product is incorporated complies with the EMC legislation of the country of use. Within the European Union, equipment into which this product is incorporated must comply with 89/336/EEC, Electromagnetic Compatibility.

When installed as recommended in this User Guide, the radiated emissions levels of all Optidrives are less than those defined in the Generic radiated emissions standard EN50081-2. When correctly fitted with an Optifiter (Mains filter), the conducted emission levels are less than those defined in the Generic radiated emissions standard EN50081-1 (class B) for screened cable lengths of < 5m and with EN50081-2 (class A) for screened cable lengths of < 25m.

WARRANTY

All Invertek Drives Ltd (IDL) products carry a 2-year warranty, valid from the date of manufacture. This date is clearly visible on the rating label.

Complete Warranty Terms and Conditions are available upon request from your Moeller representative.

Distributed by :
MOELLER ELECTRIC LTD
 PO Box 35,
 Gatehouse Close
 Aylesbury,
 Buckinghamshire, UK
 HP19 3DH

Tel +44 (0) 1296 393322
 Fax +44 (0) 1296 392413
 E-mail enquiry@moeller.co.uk
 Internet www.moeller.co.uk

Part No. 82-ODMAN-MEL Rev 11, ECN0018
 September 2000

MANUFACTURED BY INVERTEK DRIVES LTD, www.invertek.co.uk

MECHANICAL INSTALLATION

CAUTION

- Carefully inspect the Optidrive before installation to ensure it is undamaged.
- Store the Optidrive in its box until wanted. Storage should be clean and dry. Temperature range -40°C to +60°C.
- Install the Optidrive on a flat, vertical, flame-resistant vibration-free mounting within an IP54 or equivalent enclosure (EN60529).
- Flammable material should not be placed close to the drive.
- The entry of conductive or flammable foreign bodies should be prevented.

MECHANICAL INSTALLATION

Optidrives can be installed side-by-side with their heatsink flanges touching. This gives adequate ventilation space between them.

If the Optidrive is to be installed above another drive or any other heat-producing device, the minimum vertical spacing is 100mm. The enclosure should either be force-ventilated or large enough to allow natural cooling. Allow 0.1 m³ per kW of drive rating. Max. ambient temperature 50°C, min. -5°C.

DIMENSIONS

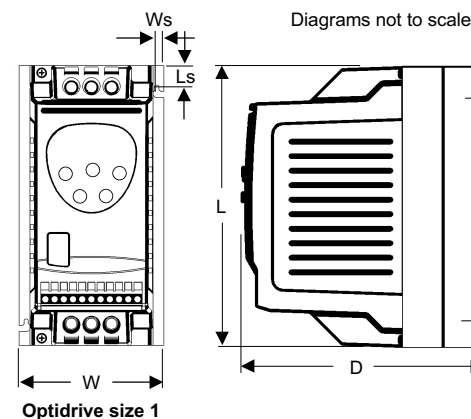

MECHANICAL DIMENSIONS

	Optidrive Size 1	Optidrive Size 2	Optidrive Size 3	Optidrive Size 4
Length (L)	155mm	260mm	260mm	520mm
Width (W)	80mm	100mm	171mm	340mm
Depth (D)	130mm	175mm	175mm	220mm
Width to screw centre (Ws)	4mm	4mm	4mm	9.5mm
Length to screw centre (Ls)	25mm	25mm	25mm	50mm
Number of fixing screws	2 x M4	2 x M4	4 x M4	4 x M8

ELECTRICAL INSTALLATION

WARNING

- Optidrives should be installed only by qualified electrical persons and in accordance with local and national regulations and codes of practice.
- Electric shock hazard!** Disconnect and **ISOLATE** the Optidrive before attempting any work on it. High voltages are present at the terminals and within the drive for up to 10 minutes after disconnection of the electrical supply.
- Where the electrical supply to the drive is through a plug and socket connector, do not disconnect until 10 minutes have elapsed after turning off the supply.
- Ensure correct grounding (earthing) connections. See Connections diagram at right.

CAUTION

- Ensure that the supply voltage, frequency and phases (3-ph or single) agree with the rating of the Optidrive as delivered.
- An isolator or other disconnecting device should be installed between the power supply and the drive.
- Never connect the power input cabling to the Optidrive output terminals UVW.
- Protect the drive by slow-blowing HRC fuses or MCB located in the input cabling.
- Do not install any type of automatic switchgear between the drive and the motor.
- Wherever control cabling is close to power cabling, maintain a minimum separation of 100 mm and arrange crossings at 90°.
- Ensure that screening or armouring of power cables is effected in accordance with the Connections diagram at right.
- Ensure that input and output power terminal screws are tightened to 1Nm

ELECTRICAL INSTALLATION

For connections see Power Connections and Grounding diagram at right. Refer to the DATA overleaf for the sizes of cabling and wiring. The earth cable must be sufficient to carry the prospective earth fault current. It is recommended that the power cabling should be 3-core or 4-core PVC-insulated screened cable, laid in accordance with local industrial regulations and codes of practice.

GROUNDING (EARTHING)

The ground terminal of each Optidrive should be individually connected DIRECTLY to the site earth (ground) busbar (through the Filter if installed) as shown in the diagram at right. Optidrive ground connections should not loop from one drive to another, or to or from any other equipment. Ground loop impedance must conform to local industrial safety regulations.

OPERATION

WARNING

- The STOP function does not remove potentially lethal high voltages. **ISOLATE** the drive and wait 10 minutes before starting any work on it.
- Parameter P-01 can be set to operate the motor at up to 30,000 rpm. Take care with the setting of this parameter.
- If it is desired to operate the drive at any frequency/speed above the rated speed (P-09/ P-10) of the motor, consult the manufacturers of the motor and the driven machine about suitability for overspeed operation.
- The fan fitted to the bottom of the Optidrive starts automatically when the heatsink temperature reaches approximately 40°C. At room temperature, the fan will be stopped.

CONTROL TERMINAL BLOCK

Default status

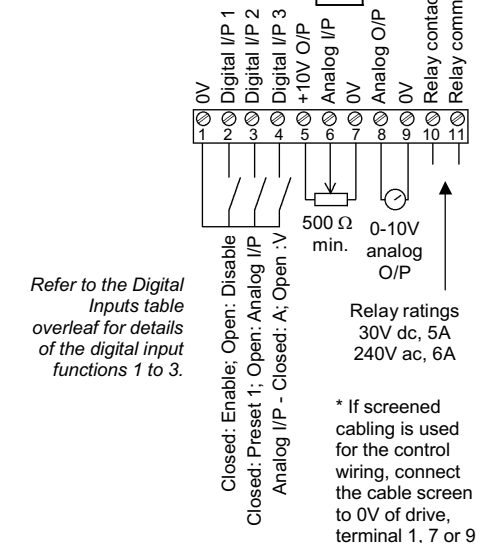

EASY START-UP

When delivered, the Optidrive is in the default state, meaning that it is set to operate in Terminal mode and all parameters (P-xx) have the default values as shown overleaf.

- Connect a control switch between terminals 1 and 2.
- Connect a potentiometer (500 ohm min.) between terminals 5 and 7, and wiper to terminal 6.
- Set the control switch between pins 1 and 2 open so that the drive is 'disabled'.
- With the potentiometer set to zero, switch on the supply to the drive. The display will show StoP.
- Close the control switch, terminals 1-2. The drive is now 'enabled' and the output frequency/speed are controlled by the potentiometer. The display shows zero speed in Hz (H 0.0) with the potentiometer turned to minimum.
- Turn the potentiometer to maximum. The motor will accelerate to 50Hz (the default value of P-01) under the control of the accelerating ramp time P-03 (5s). The display shows H 50.0 (50Hz) at max speed.
- To display motor current (A), briefly press the Navigate key ⇐.
- Press ⇐ again to return to speed display.
- To stop the motor, either turn the potentiometer back to zero or disable the drive by opening the control switch (terminals 1-2).
- If the enable/disable switch is opened, or the potentiometer is turned to zero, the display shows speed decreasing to zero under the control of the decelerating ramp time P-04. When zero is reached, the drive then displays StoP at which point the drive is disabled.

KEYPAD (PUSHBUTTON) CONTROL

- Connect a control switch between terminals 1 and 2.
- Press and hold the Navigate key ⇐ to access Parameter Edit mode. Change P-12 to 1 or 2.
- Close the control switch (terminals 1 & 2) and push the START button on the drive. Increase / decrease speed using the UP / DOWN keys. Push the STOP button to stop the drive.
- For remote push button operation see

MANAGING THE KEYPAD

When the drive is delivered from the factory, only the Standard Parameter Set (see overleaf) is accessible. To access the Standard Parameter Set, press the Navigate key ⇐ for >1 sec.

- Scroll through P-01 to P-14 (and roll over to P-01) by pressing ▲ or ▼.
- To display the parameter value, press ⇐.
- To edit the parameter value, press ▲ or ▼.
- To return to the parameter number, press ⇐.
- To exit from edit mode, press ⇐ for >1 sec or press no button for >20 sec.
- To access the Extended Parameter Set, set P-14 = 101 and press ⇐

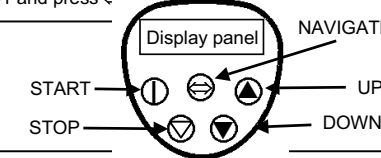

NOTE To prevent unauthorised access, make P-37 = any value from 0 to 9999.

- When in the Extended Parameter Set (except P-00), the display will revert to normal if no button is pressed for >20 sec.
- When P-00 is accessed, the display will revert to normal if no button is pressed for >60 sec.

TO SAVE CHANGES to Parameter settings, switch the power supply off and wait for the drive to power down (screen blank) before switching on. NOTE that this assumes P-38 = 0 (default). If P-38 = 1, changes are not saved.

TO RESTORE ALL DEFAULT VALUES, stop the drive and when display shows StoP, press and hold the ▲, ▼ and STOP keys simultaneously. The display will show P-DEF. Access code P-37 will revert to 101 but the hours-run meter P-39 is not affected. Press STOP to resume normal operation.

SIMPLE PARAMETER ADJUSTMENTS

The factory-set defaults may give satisfactory performance, however certain adjustments may be beneficial.

Maximum and Minimum Speeds P-01 & P-02 Set P-01 to the maximum speed and P-02 to the minimum speed for your application. These limits are mirrored for negative speeds.

Acceleration and Deceleration P-03 & P-04 Ramps which are too short will cause the drive to deliver currents in excess of full load current and may result in it tripping out or stalling the motor.

Stop Mode P-05 When ramp to stop (P-05 = 0) is selected, the drive decelerates the motor at the rate set by decel ramp time P-04.

If a non-zero minimum speed is set in P-02, the motor will ramp (P-03) to this minimum speed as soon as the drive is enabled. When disabled, the motor will ramp to zero then disable (P-05 = 0).

If it is preferred that the motor and load should decelerate naturally, ie freewheel, set P-05 = 1.

Torque/Speed Characteristic P-06 Certain loads such as fans and centrifugal pumps need very little torque at low speed. Set P-06=1 to reduce power loss at low speeds for this load type.

Rated Current, Rated Frequency and Rated Speed P-08, P-09, P-10. Parameters P-08 and P-09 should be set to correspond with the rated current and frequency shown on the motor rating plate. Parameter P-10 is optional. If this parameter is set to zero (default state), speed will be displayed in Hz; if speed indication is required in rpm, enter the motor rated speed (speed at full load) from the motor rating plate. This also activates the slip compensation feature which improves speed regulation/ holding for different load conditions.

Voltage Boost P-11 Any load which is 'sticky' to start will benefit from a voltage boost on starting. P-11 permits a boost of up to 25% of full motor voltage to be applied.

NOTE: Use of this parameter increases motor heating at low speeds.

Terminal or Keypad Control P-12 Terminal control is used when the drive needs to be controlled from some remote point, as for example by the action or status of a machine or system.

Keypad control is used when local manual control is preferable, and for commissioning.

Extended Parameter Set P15 to P-40 and P-00 The Extended Parameter Set is intended for use by specialist drives engineers and technicians and will not generally be required for simple applications.

OPERATING IN KEYPAD MODE

- With P-12 set to 1:**
- Enable the drive. The display will show StoP.
 - Press the START key. The display shows H 0.0.
 - Press ▲ to increase speed.
 - The drive will run forward, increasing speed until ▲ is released. The rate of acceleration is limited by the setting in P-03.

Either Press ▼ to decrease speed.

- The drive will decrease speed until ▼ is released. The rate of deceleration is limited by the setting in P-04.

- Or Press the STOP key.**
- The drive will decelerate to rest at the rate set in P-04.
 - The display will finally show StoP at which point the drive is disabled.

- With P-12 set to 2:**
- Press the START key. The display changes to H 0.0.
 - Press ▲ to increase speed.
 - The drive will run forward, increasing speed until ▲ is released. Acceleration is limited by the setting in P-03. The maximum speed is the speed set in P-01.
 - Press the START key again. The motor will

POWER CONNECTIONS AND GROUNDING

Each drive star connected to system earth point

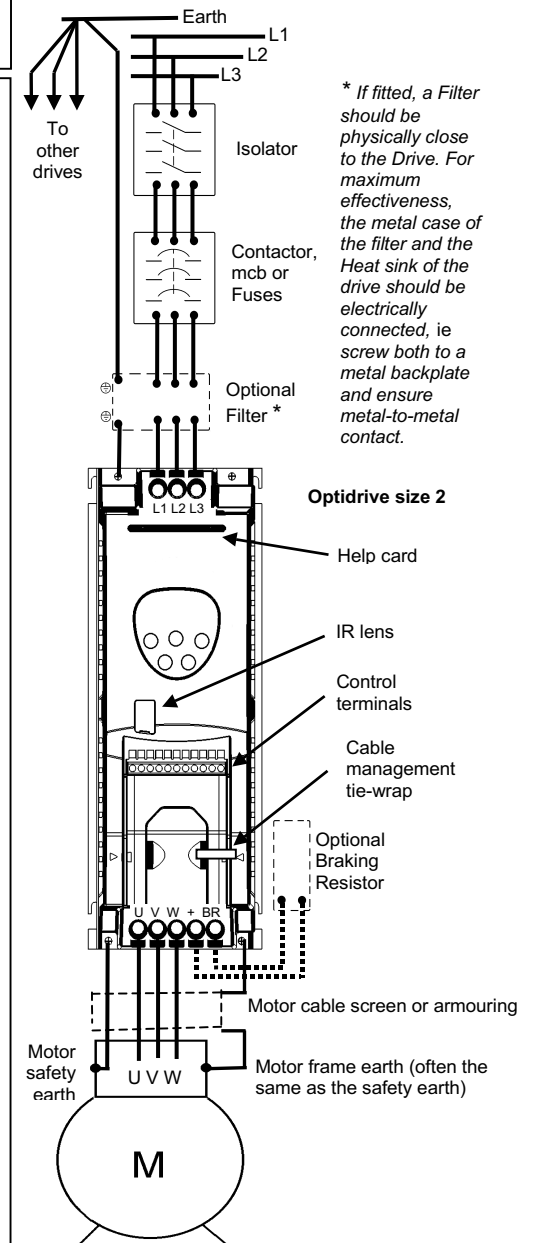

KEY TO SYMBOLS IN THE DISPLAY

H 50.0 = 50 Hz output speed A 4.5 = 4.5 amps rms output current 1465 = 1465rpm output speed StoP = drive disabled
 P 01 = Parameter P-01 L = Parameter locked (P-38) E = Error. Parameter can only be changed in STOP mode
 Flashing decimal points = drive is in overload StndbY = drive enabled, but output temporarily disabled to save energy (P-29)

STANDARD PARAMETER SET

Par.	Description	Range	Default	Explanations	Set to
P-01	Maximum speed	P-02 to 5*P-09 (max 545Hz)	50Hz	Maximum speed limit – Hz or rpm. See P-10.	
P-02	Minimum speed	0 to P-01 (max 545 Hz)	0Hz	Minimum speed limit – Hz or rpm. See P-10.	
P-03	Accel ramp time (s)	0 to 3,000s	5s	Accelerating time from 0 to maximum speed in seconds.	
P-04	Decel ramp time (s)	0 to 3,000s	5s	Decelerating time from maximum speed to 0 in seconds.	
P-05	Stop mode select	0, 2: Ramp stop 1: Coast to stop	0	On loss of supply, 0: Mains loss ride thro' 2: Ramp at P-07 to stop	
P-06	V/F characteristic	0: Constant torque, 1: Pump/fan	0	Either V = kf (linear) or V = kf ² (pumps / fans with HVAC rating).	
P-07	Rapid decel ramp time (s)	0.0 to 25s. (Disabled when 0.0s)	0.0s	Decel ramp time after mains loss (P-05 = 0 or 2) (see also P-19 table)	
P-08	Motor rated current	25% -100% of drive current rating	Drive rating	Rated (nameplate) current of the motor (Amps)	
P-09	Motor rated frequency	25 to 545Hz	50 Hz	Rated (nameplate) frequency of the motor. Changing P-09 resets P-02, P-10 & P-28 to 0, & P-01=P-09.	
P-10	Motor rated speed	0, P-09*12 to P-09*60 eg for 50Hz motor, range is 600 to 3000 rpm	0	When non-zero, speed is displayed in rpm in parameters P-01, P-02, P-20...P-23, P-27 and P-28; also slip compensation is automatically activated whenever this parameter is non-zero. – see also P-24.	
P-11	Voltage boost	0 to 25% of max output voltage	3%	Applies an adjustable boost to the Optidrive voltage output at low speed to assist with starting 'sticky' loads.	
P-12	Terminal or Keypad control	0, 3: Terminal control 1: Keypad control – fwd only 2: Keypad control – fwd and rev	0 (Terminal control, no IR transmit)	3: Terminal control with Optidrive speed info transmitted via IR link. When P-12 = 2, the keypad START key toggles between forward and reverse, after STOP drive always starts in a forward direction.	
P-13	Trip log	Last four trips stored	Read only	Most recent 4 trips stored in order of occurrence, ie on entry, display shows most recent first. Press ▲ or ▼ to step through all four.	
P-14	Extended menu access	Code 0 to 9999	0	Set to "101" (default) for extended menu access. Change code in P-37 to prevent unauthorised access to the Extended Parameter Set.	

EXTENDED PARAMETER SET

Par.	Description	Range	Default	Explanations	Set to
P-15	Motor rated voltage	230V product: 80V to 250V 400V product: 80V to 500V	0V 400V	When P-15 is non-zero, the applied motor voltage is controlled and scaled so that the specified voltage is achieved at rated freq (P-09).	
P-16	Analog input format (V / mA)	Voltage: 0-10V, 10-0V, -10-10V Current: 4-20mA, 0-20mA, 20-4mA	0-10V	Analog input format (on terminal 6). Set to "-10 -10" for bipolar analog input.	
P-17	Effective Power stage Switching frequency	8, 16, 32 kHz (sizes #1, #2) 8, 16 kHz (sizes #3, #4) (see Optidrive Data tables at right)	16kHz (8kHz 400V Optidrives)	Effective Power stage switching frequency. Improvements in acoustic noise and output current waveform occur with increasing switching frequency at the expense of increased losses within the drive.	
P-18	Relay output function	0: Drive enabled 1: Drive healthy 2: Set speed 3: Motor at zero 4: Motor at max speed (P-01)	1 : (Drive healthy)	Relay output function. Contacts closed if selected condition is true. Zero speed is set when the output frequency is < 5% of base frequency.	
P-19	Digital inputs function select	0 to 10	0	Defines function of digital inputs. (See also P-16 and Digital Inputs table at right.)	
P-20	Preset / Jog speed 1	-P-01 (reverse) to P-01	50Hz	Defines Preset / Jog speed 1.	
P-21	Preset / Jog speed 2	-P-01 (reverse) to P-01	0 Hz	Defines Preset / Jog speed 2.	
P-22	Preset / Jog speed 3	-P-01 (reverse) to P-01	0 Hz	Defines Preset / Jog speed 3.	
P-23	Preset / Jog speed 4	-P-01 (reverse) to P-01	0 Hz	Defines Preset / Jog speed 4.	
P-24	Slip compensation	20% to 250%	100%	Slip correction factor. Value defines the %age of the internally calculated slip compensation value to be applied. See also P-10.	
P-25	Analog output function	(A) 0: Motor Speed 1: Motor current (D) 2: Drive enabled 3: Set speed	0	Analog output select. (When P-25 = 0, 10V = 100% of P-01 otherwise 10V = 200% of P-08). P-25 = 2 or 3 gives a 5V digital output	
P-26	V/F characteristic adjustment factor	20% to 250%	100%	Used with P-29 to adjust the V/F characteristic. When P-26 > 100%, motor voltage is increased, when P-26 < 100%, voltage is reduced.	
P-27	Skip freq / speed	0 to P-01 (max)	0 Hz	Centre point for skip frequency band. The skip frequency band defined by P-27, P-28 is mirrored around zero for negative speeds.	
P-28	Skip freq / speed band	0 to 100% of rated speed/freq, P-09	0 Hz	Width of skip frequency band, the centre of which is defined by P-27.	
P-29	V/F characteristic adjustment frequency	0 to base frequency (P-09) (Function disabled when set to zero)	0 Hz	Sets the frequency at which the V/F adjustment factor in P-26 has full effect. This allows the motor voltage applied at the frequency in P-29 to be increased or decreased by the factor set in P-26.	
P-30	Drive start mode	Edge-r: Close Digital input 1 after power up to start drive Auto-0: drive runs whenever Digital input 1 closed. Auto-1..4: as Auto-0, except 1..4 Attempts to restart after a trip	Auto-0	When set to Edge-r, if drive is powered up with Digital Input 1 closed (enabled), drive will not run. The switch must be closed after power up or after a clearing a trip for the drive to run. When set to Auto-0, drive will run whenever digital input 1 is closed (if not tripped). Auto-1..4 makes 1..4 attempts to automatically restart after a trip (20s between attempts). If fault has cleared drive will restart. Drive must be powered down to reset auto reset counter.	
P-31	DC injection voltage	0.1 to 20% of max voltage	10%	If P-05 selection is 'ramp to stop', P-31 sets the level of DC braking applied when the ramp reaches zero.	
P-32	DC injection braking time	0 to 60s	0s	If P-05 selection is 'ramp to stop', P-32 sets the duration of DC braking applied when the ramp reaches zero.	
P-33	DC injection on enable	0: Inactive 1: Enabled	0	When 1, DC injection is applied whenever the drive is enabled	
P-34	External Brake Resistor	0: No brake resistor fitted 1: Optidrive braking resistor 2: Customer specified resistor	0	Activates the internal braking transistor. When P-34 = 1 the braking resistor is protected by the drive against overload. When P-34 = 2, a thermal overload relay must be used to protect the resistor and drive.	
P-35	Speed reference scaling factor (analog or digital)	20% to 250% (40% to 500% if P-01 > 2.5x P-09)	100%	Scales the analog input at control terminal 6 up or down, or the digital reference in keypad (or Slave) mode up or down.	
P-36	Drive address (s-comms)	0 to 63	1	Distinct drive address for serial comms. 0 = comms disabled.	
P-37	Access code definition	0 to 9999	101	Defines Extended Parameter Set access code, P-14.	
P-38	Parameter access lock	0: Parameters can be changed, auto-saved on power down 1: Parameter changes not saved on power down 2: Read-only. No changes allowed.	0 (write access and auto-save are enabled)	Controls user access to parameters. When P-38 = 0, all parameters can be changed and these changes will be stored automatically. When P-12 = 1, changes may be made but these will not be stored when the Optidrive powers down. When P-38 = 2, parameters are locked and cannot be changed, preventing unauthorised access.	
P-39	Hours run meter	0 to 99999 hours	Read only	Not affected by reset-to-default command.	
P-40	Drive identifier	Drive rating/Software version	Read only	Power, size and software version codes.	

PARAMETER ZERO

Par.	Description	Range	Default	Explanations	Set to
P-00	Provides a read only window into the drive. Access, scroll, change and exit are as for any other parameter. The selected variable is indicated at the left hand side of the display.	1 to 9	1	1 Unscaled analog input % 2 Speed reference from scaled (P-35) analog input Hz 3 Pre-ramp speed reference Hz 4 Post-ramp speed reference Hz 5 Slip speed Hz 6 Stator field frequency Hz 7 Applied motor voltage V 8 DC bus voltage V 9 Optidrive internal thermistor (NTC) value	

OPTIDRIVE DATA – Motors 0.37 to 2.2kW, single and 3-phase 230V

Size	1	1	1	1	2	2
Optidrive model reference	OD-xxxxx-MEL	120037	120055	120075	120110	220220
Supply voltage	+/-10%	220-240	220-240	220-240	220-240	220-240
Phases	1 or 3	1 or 3	1 or 3	1 or 3	1 or 3	1 or 3
Motor output rating kW	0.37	0.55	0.75	1.1	1.5	2.2
Motor output rating HP (nom.)	0.5	0.75	1.0	1.5	2.0	3.0
Output current A	2.3	3.1	4.3	5.8	7.0	10.5
Fuse or MCB rating 3-phase A	5	5	5	10	10	10
Fuse or MCB rating 1-phase A	10	10	10	20	20	30
Max. amb. temp. °C for switching freq. >8kHz	50	50	40	40	50	40
Motor cable size mm ²	1.0	1.0	1.0	1.5	1.5	1.5
Maximum motor cable length m	50	50	50	100	100	100
Weight kg	1.0	1.0	1.0	1.0	2.5	2.5
Min. Braking Resistor Ω	n/a	n/a	n/a	n/a	33	22

OPTIDRIVE DATA – Motors 0.75 to 37.0kW, 3-phase 400V

Size	1	1	2	2	2	3	3	3	3	4	4	4	4	
OD-xxxxx-MEL	140075	140150	240075	240150	240220	240400	340550	340750	341100	341500	441850	442200	443000	443700
Volts +/-10%	380-480	380-480	380-480	380-480	380-480	380-480	380-480	380-480	380-480	380-480	380-480	380-480	380-480	380-480
Phases	3	3	3	3	3	3	3	3	3	3	3	3	3	3
Output kW	0.75	1.5	0.75	1.5	2.2	4.0	5.5	7.5	11.0	15.0	18.5	22.0	30.0	37.0
Output HP (nom.)	1.0	2.0	1.0	2.0	3.0	5.5	7.5	10	15	20	25	30	40	50
Output A	2.2	4.1	2.2	4.1	5.8	9.5	13.0	16.0	25.0	29.5	39	46	61	72
MCB rating A	5	10	5	10	10	16	20	32	40	40	50	60	80	100
Max°C at 16kHz	40	40	50	40	50	40	50	40	20	-	40	30	20	-
Max°C at 32kHz	30	30	50	30	50	30	-	-	-	-	-	-	-	-
Cable size mm ²	1.0	1.0	1.0	1.0	1.5	1.5	2.5	2.5	4	6	10	10	16	16
Cable length m	10	10	50	100	100	100	100	100	100	100	100	100	100	100
Weight Kg	1.0	1.0	2.5	2.5	2.5	2.5	5.0	5.0	5.0	5.0	25	25	26	26
Min brake R Ω	-	-	47	47	47	33	22	22	22	22	12	12	12	12

DIGITAL INPUTS

P-19	Input 1 function	Input 2 function	Input 3 function
0	Open: Stop (disable) Closed: Run (enable)	Open: Analog speed reference Closed: Preset / Jog Speed 1	Open: Voltage analog input Closed: Current analog input
1	Open: Stop (disable) Closed: Run (enable)	Open: Analog speed reference Closed: Preset / Jog Speed 1 or 2, selected by Digital Input 3	Open: Preset / Jog Speed 1 Closed: Preset / Jog Speed 2
2	Open: Stop (disable) Closed: Run (enable)	Digital Input 2 Open + Digital Input 3 Open = Preset / Jog Speed 1 Digital Input 2 Closed + Digital Input 3 Open = Preset / Jog Speed 2 Digital Input 2 Open + Digital Input 3 Closed = Preset / Jog Speed 3 Digital Input 2 Closed + Digital Input 3 Closed = Preset / Jog Speed 4	
3	Open: Stop (disable) Closed: Run (enable)	External trip input: Open: TRIP; Closed: no trip.	Open: Analog speed reference Closed: Preset / Jog Speed 1
4	Open: Stop (disable) Closed: Run (enable)	Open: Run forward Closed: Run reverse	Open: Analog speed reference Closed: Preset / Jog Speed 1
5	Open: Fwd Stop (disable) Closed: Fwd Run (enable)	Open: Reverse Stop (disable) Closed: Reverse Run (enable)	Open: Analog speed reference Closed: Preset / Jog Speed 1
6	Open: Stop (disable) Closed: Run (enable)	Open: Run forward Closed: Run reverse	External trip input: Open: TRIP; Closed: no trip.
7	Open: Fwd Stop (disable) Closed: Fwd Run (enable)	Open: Reverse Stop (disable) Closed: Reverse Run (enable)	External trip input: Open: TRIP; Closed: no trip.
8	Open: Stop (disable) Closed: Run (enable)	Open: Run forward Closed: Run reverse	Open: Preset / Jog Speed 1 Closed: Preset / Jog Speed 2
9	Open: Fwd Stop (disable) Closed: Fwd Run (enable)	Open: Reverse Stop (disable) Closed: Reverse Run (enable)	Open: Preset / Jog Speed 1 Closed: Preset / Jog Speed 2
10	Normally Open (N.O.) Momentary close to run (Enable)	Normally Closed (N.C.) Momentary open to Stop (disable)	Open: Analog speed reference Closed: Preset / Jog Speed 1

- 'Forward' speed is defined as clockwise rotation looking at the shaft end of the motor.
- When P-19 = 0 the analog input will be configured for 0-10V when Digital Input 3 is open. When Digital Input 3 is closed, the analog input assumes a 4-20mA format if P-16 is set to 0-10V, otherwise the analog input will be configured for the format set in P-16. For P-19 > 0, the analog input is defined by the setting of P-16.
- P-19 = 5, 7 or 9 selects the 'wire break' stop function. Opening digital input 1 or 2 (eg wire break) will disable the drive. This setting also activates the fast stop ramp (P-07) when digital inputs 1 and 2 are closed simultaneously.

TROUBLESHOOTING

TO CLEAR A TRIP CONDITION Remove the condition which caused the trip and press the STOP key. The drive will restart according to the mode selected by P-30.
 If the motor is stopped and the display shows StoP, there is no fault; the drive output is disabled and ready to run.
 NOTE: If the application requires terminals 1 and 2 to be permanently connected, P-30 must be set to "Auto-0".

Fault Code	What has happened	What to do
P-deF	Default parameters loaded.	Press STOP key to acknowledge and enter parameter values.
O-I	Over current on drive output. Excess load on the motor.	Motor at constant speed: investigate overload or malfunction. Motor starting: load stalled or jammed. Motor accelerating/decelerating: accel/decel time too short. Check for star-delta motor wiring error.
O-Uolt	Over voltage on DC bus.	Supply problem, or increase decel ramp time P-04.
U-Uolt	Under voltage on DC bus.	This occurs routinely when power is switched off. If it occurs during running, check power supply voltage.
OI-br	Brake resistor short circuit.	Check cabling first. If ok, check resistor for burn out.
I.t-trP	Overload. 150% current for >1 min.	Check driven machine; drive may be too small for the load
th-Fit	Faulty thermistor on heatsink.	Refer to your IDL Authorised Distributor.
E-triP	External trip (on digital input 2 or 3)	External trip on digital input – see P-19 (motor thermistor ?)
EE-F	EEPROM fault. Parameters not saved, defaults reloaded.	Try again. If problem recurs, refer your IDL Authorised Distributor.
PS-Fit	Internal power stage fault.	Refer to your IDL Authorised Distributor.
O-t	Heatsink over temperature.	Check drive ambient temp. Added space or cooling needed?
Ain-F	Hardware fault.	Refer to your IDL Authorised Distributor.
lin-F	Current analog input out of range	Check input current in range defined by P-16
OL-br	Braking Resistor Overload	Increase decel. time, P-04 or reduce braking resistor value
SC-trP	Serial communications trip	Check OptiLink integrity between drives connected optically

Acceleration/ deceleration: Very short ramp times may require >150%. This may result in the accel/decel rate not being achieved, and/or O-I fault.
Overload protection: When the drive is delivering >100% full load current, an I.t integral will result in the drive tripping, should the I.t limit be exceeded. This occurs after 1 minute at 150%. When overloaded, the Optidrive display will flash.

GENERAL TECHNICAL DATA

- Supply frequency 48 to 62 Hz.
- Maximum permissible 3-phase supply imbalance 3%.
- Max. ambient temperature 50 °C.
- Relative humidity must be less than 95% (non-condensing).
- Max. altitude 2000 m.
- Derate above 1000 m, 1% per 100 m.
- Derate output current 5%/°C above max. ambient temp (see * table) up to 50°C max
- I x t protection above 100% output current.
- 150% overload protection for 60 sec.
- 175% overload allowable for 2 sec.
- Storage temperature range -40 to +60 °C.

OPTIDRIVE FEATURES

- Speed range 0 to 545Hz (0 to 32,700 rpm).
- Speed regulation 1.0%.
- On-board brake module (sizes 2, 3 and 4 only).
- Power output constant torque or fan/pump characteristic.
- Drive efficiency typically 95%
- Motorised potentiometer function
- Independent fast ramp to stop

CONTROL FEATURES

- Three programmable digital inputs.
- One bipolar analog input (voltage or current).
- One analog output (current or speed).
- One programmable output relay.
- Analog input update time less than 8 ms.
- Control terminals galvanically isolated to >2.5kV
- Control terminal outputs short-circuit-proof.
- Four preset speeds selectable.
- Auto restart selectable.
- Skip frequencies selectable.
- Near-silent motor running (32kHz effective switching frequency).
- Selectable switching frequencies 8, 16, 32kHz

OPTIDRIVE OPTIONS

- The following additional products are available:
- Additional EMC filters to EN 50081-1 and EN 50081-2 (industrial) for long motor cables.
 - LCD infrared remote control unit 'Optiwand'.
 - Multi-language LCD display and parameter copy facility in Optiwand.
 - Braking resistor (sizes 2, 3 & 4 Optidrive).
 - RS232/485 serial communications unit.
 - Profibus DP communication unit.
 - DeviceNet communication unit.

For further information, please consult your local Moeller representative.

CONFORMITY with STANDARDS

- CE-marked for Low Voltage Directive.
- IEC 664-1 Insulation Coordination within Low Voltage Systems.
- UL 840 Insulation coordination for electrical equipment.
- EN50081-2 EMC Generic Emissions Standard, Industrial Level.
- EN50082-2 EMC Generic Immunity Standard, Industrial Level.
- Enclosure ingress protection, EN60529 IP20, NEMA 250.
- Flammability rating according to UL 94.

G O Jones
 G O Jones, Technical Director