

*RoHS COMPLIANT

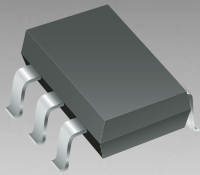

BOURNS®

Features

- Lead free device (RoHS compliant*)
- Protects 4 lines
- ESD protection
- Low capacitance 3.5 pF

Applications

- Ethernet – 10/100/100 Base T
- Cellular phones
- Video/graphics card
- USB 2.0 interface
- DVI interface

CDSOT23-SRV05-4 – Steering Diode TVS Array Combo

General Information

The markets of portable communications, computing and video equipment are challenging the semiconductor industry to develop increasingly smaller electronic components.

Bourns offers Transient Voltage Suppressor Array diodes for surge and ESD protection applications, in compact chip package SOT23-6 size format. Bourns® Chip Diodes conform to JEDEC standards, are easy to handle on standard pick and place equipment and their flat configuration minimizes roll away.

The Bourns® device will meet IEC 61000-4-2 (ESD), IEC 61000-4-4 (EFT) and IEC 61000-4-5 (Surge) requirements.

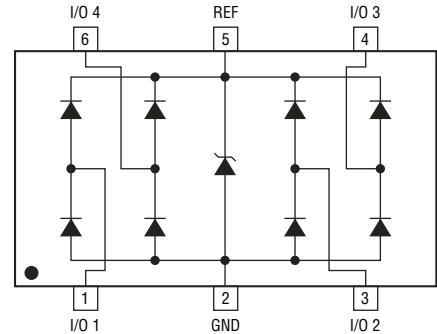

Electrical Characteristics (@ T_A = 25 °C Unless Otherwise Noted)

Parameter	Symbol	Min.	Nom.	Max.	Unit
Peak Pulse Current (t _p = 8/20 μs)	I _{PP}			43	A
Peak Pulse Power (t _p = 8/20 μs) ¹	P _{PP}			500	W
Working Peak Reverse Voltage	V _{WM}			5	V
Breakdown Voltage @ 1 mA	V _{BR}	6			V
Leakage Current @ V _{WM}	I _D			5	μA
Capacitance	C _{J(SD)}		3.5		pF
Forward Surge Rating (1/20 s @ 25 °C, I _F = 10 mA)	V _F			1.5	V
Clamping Voltage	@ I _{PP} = 2 A	V _C		12	V
	@ I _{PP} = 30 A	V _C		15	V

Note:

1. See Peak Pulse Power vs. Pulse Time.

Thermal Characteristics (@ T_A = 25 °C Unless Otherwise Noted)

Parameter	Symbol	Min.	Nom.	Max.	Unit
Operating Temperature	T _J	-55	+25	+150	°C
Storage Temperature	T _{STG}	-55	+25	+150	°C

CDSOT23-SRV05-4 – Steering Diode TVS Array Combo

BOURNS®

Mechanical Characteristics

This is a molded JEDEC SOT23-6 package with lead free Nickel-Paladium-Gold (Ni/Pd/Au) on the lead frame. It weighs approximately 15 mg and has a flammability rating of UL 94V-0.

Product Dimensions

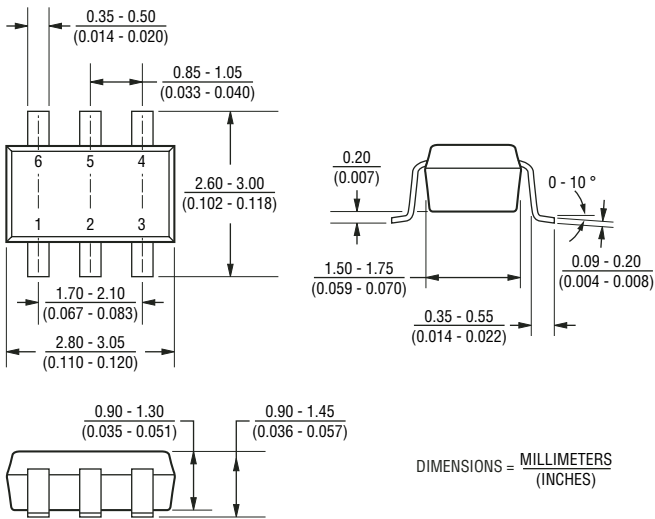

Recommended Footprint

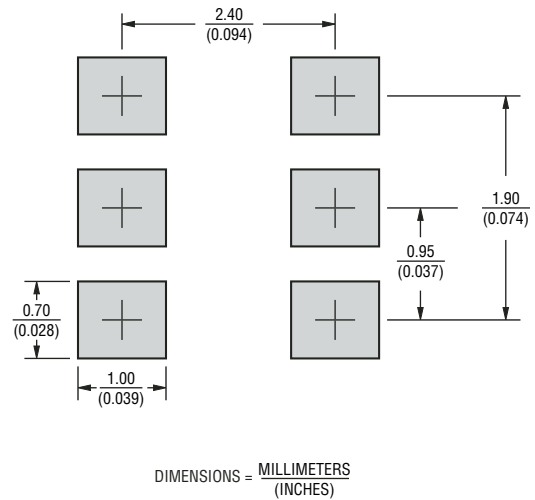

Packaging Information

The product will be dispensed in Tape and Reel format (see diagram below).

TOP SIDE VIEW
(INTO COMPONENT POCKET)

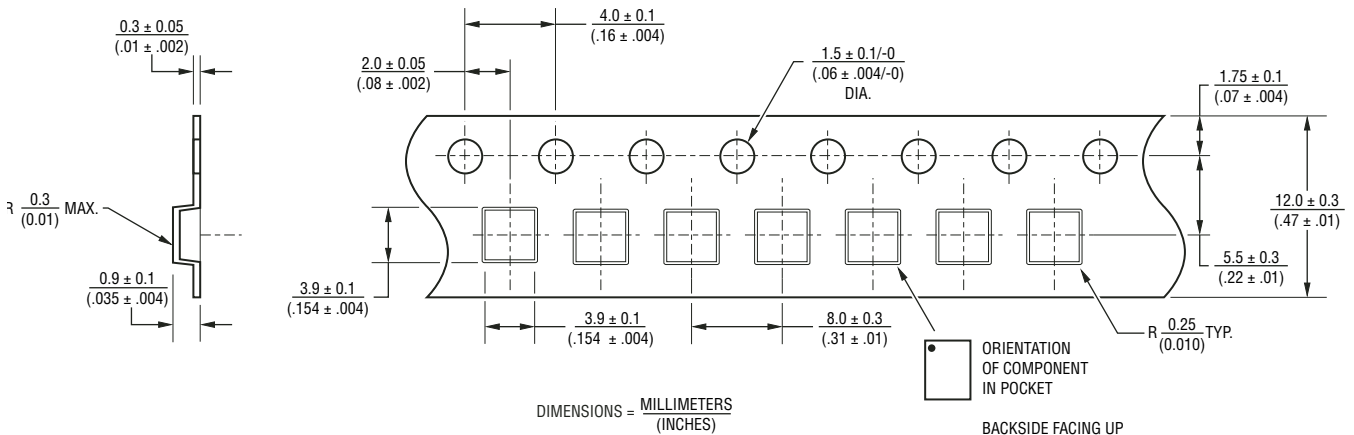

Devices are packed in accordance with EIA standard RS-481-A and specifications shown here.

CDSOT23-SRV05-4 – Steering Diode TVS Array Combo



Performance Graphs

Peak Pulse Power vs Pulse Time

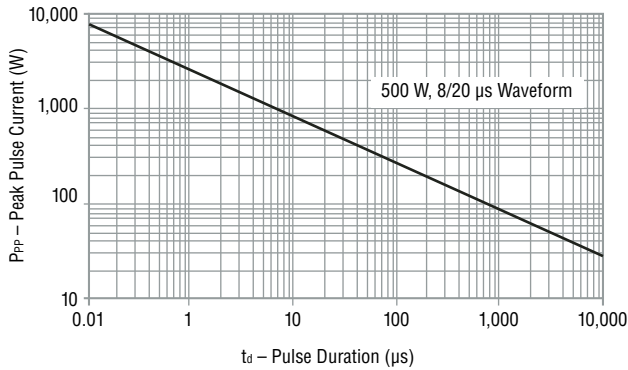

Pulse Wave Form

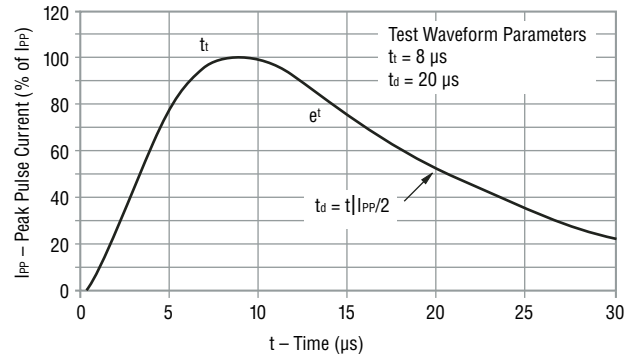

Block Diagram

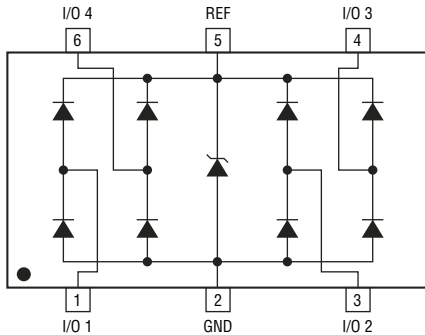

Power Derating Curve

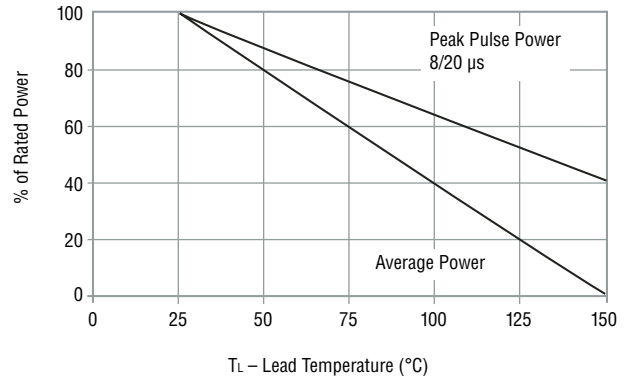

How To Order

CD SOT23 - SRV 05 - 4

Common Code _____
 CD = Chip Diode
 Package _____
 SOT23 = SOT23-6 Package
 Model _____
 SRV = Steering Diode Array
 Working Peak Reverse Voltage _____
 05 = 5 V_{RWM} (Volts)
 Number of Protection Lines _____

Typical Part Marking

CDSOT23-SRV05-4 **S5**



Reliable Electronic Solutions

Asia-Pacific:

Tel: +886-2 2562-4117 • Fax: +886-2 2562-4116

Europe:

Tel: +41-41 768 5555 • Fax: +41-41 768 5510

The Americas:

Tel: +1-951 781-5500 • Fax: +1-951 781-5700

www.bourns.com