

# AC / DC Converter

## BP5048 / BP5048-15 / BP5048-24

The BP5048, BP5048-15 and BP5048-24 are AC / DC converters which can be used to supply DC output from a commercial power supply (200 to 220 V AC). Using these modules enable simple, easy drive of microcomputers, LEDs, and other electronic components without using a transformer. They also allow set PCBs to be kept compact and lightweight, with extremely few attachments.

These products can accommodate the 200V AC power supplies used as household power supplies in Asia and Europe, as well as in buildings and facilities in Japan.

### ●Applications

Power supply circuits for vacuum cleaners, refrigerators, washing machines, air conditioners, irons, electric carpets, cordless telephones, air purifiers, humidifiers, dehumidifiers, home bakery devices, electric crock pots and rice cookers, illumination devices and other small household appliances, as well as power supply circuits for gas leakage sensors, and other industrial products

### ●Features

- 1) Elimination of a transformer enables compact, lightweight power supply boards.
- 2) Wide input voltage range. (249 to 358V DC for DC voltage conversion)
- 3) DC power supplies can be easily configured, with few attachments.
- 4) Because no transformer is used, the power supply board is less vulnerable to splitting or cracking from impact or shock.
- 5) Allow easy assemblage of components.

### ●List of the BP5048 series

	BP5048	BP5048-15	BP5048-24	Unit
Power supply voltage	249~358	249~358	249~358	V
Output voltage	12	15	24	V
Output current	300	200	200	mA

### ●Absolute maximum ratings (Ta=25°C)

Parameter	Symbol	Limits	Unit
Power supply voltage	V <sub>IN</sub>	358	V
Operating temperature range	T <sub>opr</sub>	-20~+80	°C
Storage temperature range	T <sub>stg</sub>	-25~+105	°C

### ●Recommended operating conditions (Ta=25°C)

Parameter	Symbol	Min.	Typ.	Max.	Unit
Power supply voltage	V <sub>IN</sub>	249	311	358	V <sub>(DC)</sub>

## Power Module

## ●Block diagram

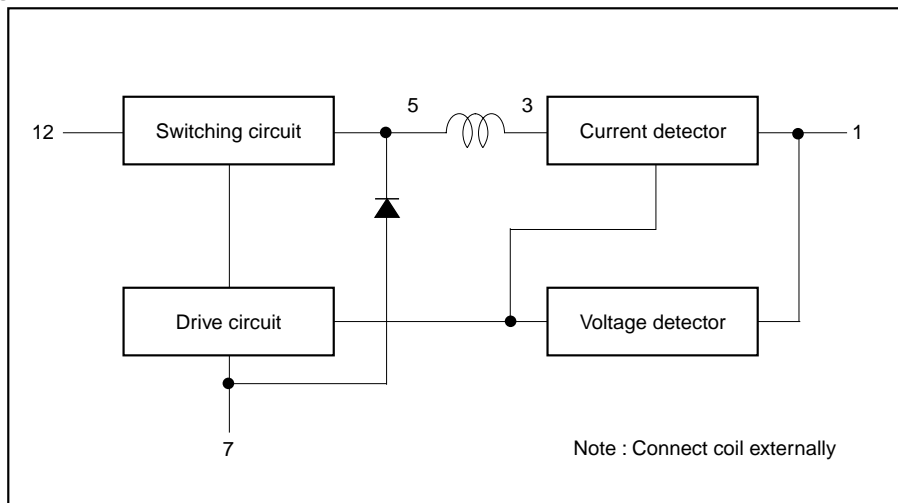

## ●Pin descriptions

Pin No.	Pin name
1	V <sub>OUT</sub>
3	COIL
5	COIL
7	COMMON
10	NC
12	V <sub>IN</sub>

Pins 2, 4, 6, 8, 9,11 are removed

●Electrical characteristics (Unless otherwise noted, T<sub>a</sub>=25°C)

## BP5048

Parameter	Symbol	Min.	Typ.	Max.	Unit	Conditions
Input voltage	V <sub>IN</sub>	249	311	358	V	DC
Output voltage	V <sub>O</sub>	11.0	12.0	13.0	V	V <sub>IN</sub> =311V, I <sub>O</sub> =100mA
Output current	I <sub>O</sub>	0	–	300	mA	V <sub>IN</sub> =311V *1
Line regulation	V <sub>r</sub>	-0.20	0.05	+0.20	V	V <sub>IN</sub> =249~358V, I <sub>O</sub> =100mA
Load regulation	V <sub>l</sub>	-0.20	0.05	+0.20	V	V <sub>IN</sub> =311V, I <sub>O</sub> =0~100mA
Output ripple voltage	V <sub>p</sub>	–	0.07	0.15	V <sub>PP</sub>	V <sub>IN</sub> =311V, I <sub>O</sub> =100mA *2
Conversion efficiency	η	65	78	–	%	V <sub>IN</sub> =311V, I <sub>O</sub> =300mA

\*1 Maximum output current varies depending on ambient temperature ; please refer to derating curve.

\*2 Spike noise is not included in output ripple voltage.

Power Module

BP5048-15

Parameter	Symbol	Min.	Typ.	Max.	Unit	Conditions
Input voltage	$V_{IN}$	249	311	358	V	DC
Output voltage	$V_O$	13.9	15.0	16.1	V	$V_{IN}=311V, I_o=100mA$
Output current	$I_o$	0	-	200	mA	$V_{IN}=311V$ *1
Line regulation	$V_r$	-0.20	0.05	+0.20	V	$V_{IN}=249\sim358V, I_o=100mA$
Load regulation	$V_l$	-0.20	0.05	+0.20	V	$V_{IN}=311V, I_o=0\sim100mA$
Output ripple voltage	$V_p$	-	0.07	0.15	$V_{PP}$	$V_{IN}=311V, I_o=100mA$ *2
Conversion efficiency	$\eta$	60	75	-	%	$V_{IN}=311V, I_o=200mA$

\*1 Maximum output current varies depending on ambient temperature ; please refer to derating curve.

\*2 Spike noise is not included in output ripple voltage.

BP5048-24

Parameter	Symbol	Min.	Typ.	Max.	Unit	Conditions
Input voltage	$V_{IN}$	249	311	358	V	DC
Output voltage	$V_O$	23.0	24.0	25.8	V	$V_{IN}=311V, I_o=100mA$
Output current	$I_o$	0	-	200	mA	$V_{IN}=311V$ *1
Line regulation	$V_r$	-0.20	0.05	+0.20	V	$V_{IN}=249\sim358V, I_o=100mA$
Load regulation	$V_l$	-0.20	0.05	+0.20	V	$V_{IN}=311V, I_o=0\sim100mA$
Output ripple voltage	$V_p$	-	0.07	0.15	$V_{PP}$	$V_{IN}=311V, I_o=100mA$ *2
Conversion efficiency	$\eta$	65	78	-	%	$V_{IN}=311V, I_o=200mA$

\*1 Maximum output current varies depending on ambient temperature ; please refer to derating curve.

\*2 Spike noise is not included in output ripple voltage.

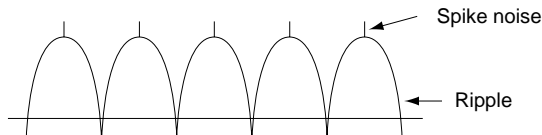

●Measurement circuits

BP5048 / BP5048-15

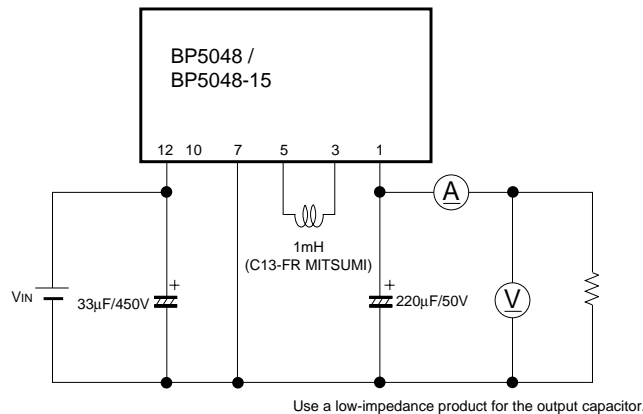

Fig.1

BP5048-24

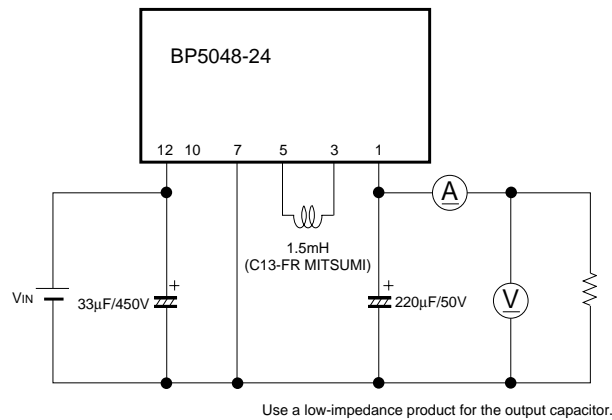
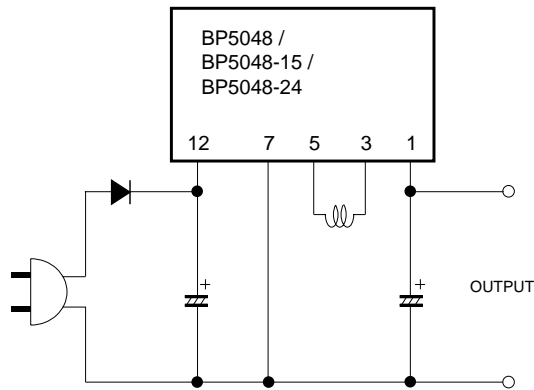

Fig.2

### ●Application example

Half wave rectifier circuit



Full wave rectifier circuit

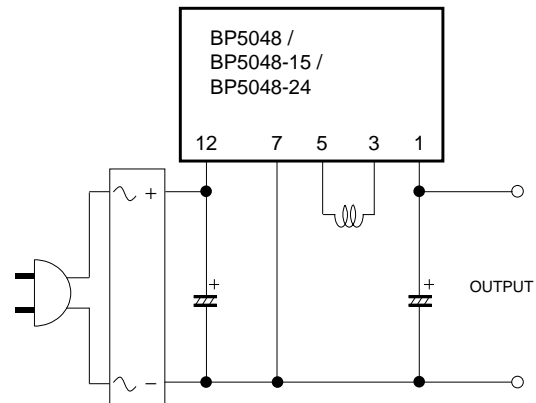

Fig.3

### ●Operation notes

- (1) Output current should be reduced with increasing ambient temperature.
- (2) Over current and shorted circuit  
The overcurrent protection circuit limits the current to about 330mA (BP5048), 240mA (BP5048-15), 230mA (BP5048-24) with drooping model. If there is any danger of the load being shorted or overcurrent being produced, always use a protective device such as a fuse.
- (3) Insulation  
These products are not insulated on the primary side, and there is a danger of electrical shock if they are touched.
- (4) Avoid subjecting these products to strong impact.
- (5) Lead pins should be securely connected. If lead pins are not securely connected, irregular voltages could be produced, causing breakdowns and damage.

Power Module

●Electrical characteristic curves

BP5048

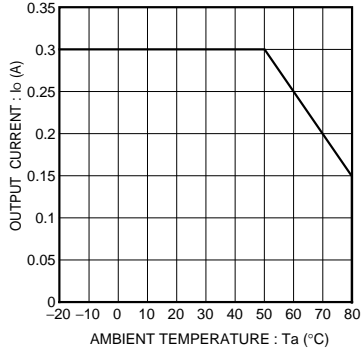

Fig.4 Derating curve

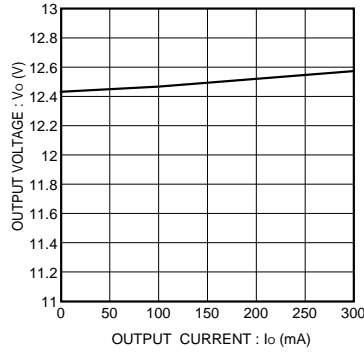

Fig.5 Load regulation

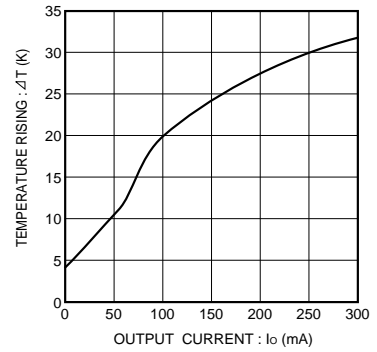

Fig.6 Surface temperature rise

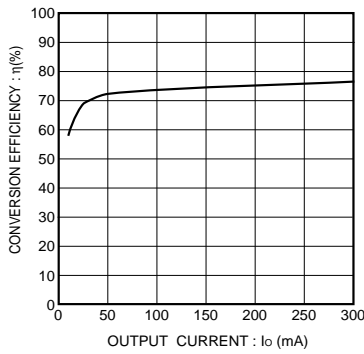

Fig.7 Conversion efficiency

BP5048-15

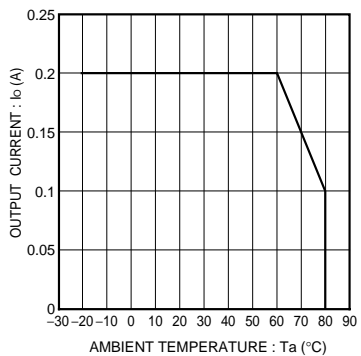

Fig.8 Derating curve

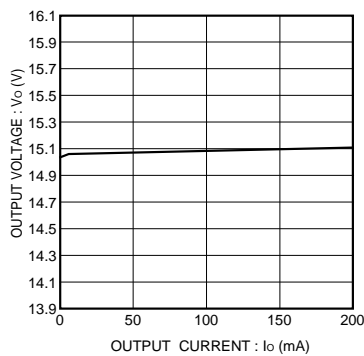

Fig.9 Load regulation

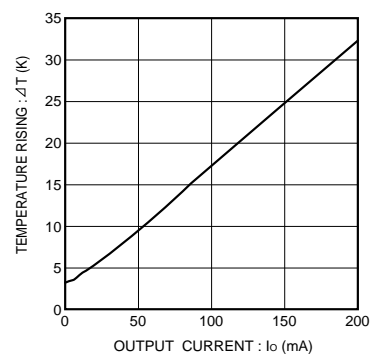

Fig.10 Surface temperature rise

Power Module

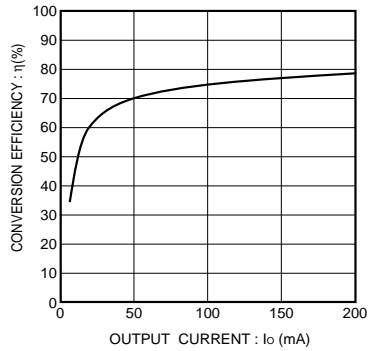

Fig.11 Conversion efficiency

BP5048-24

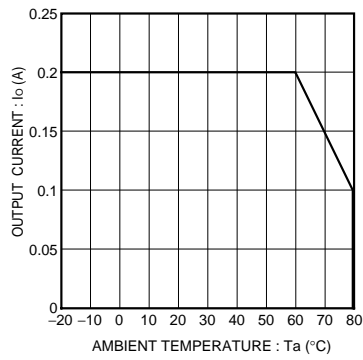

Fig.12 Derating curve

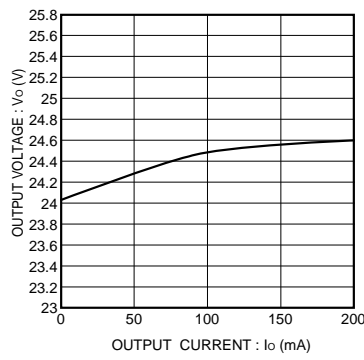

Fig.13 Load regulation

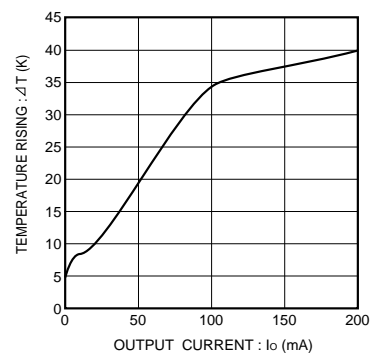

Fig.14 Surface temperature rise

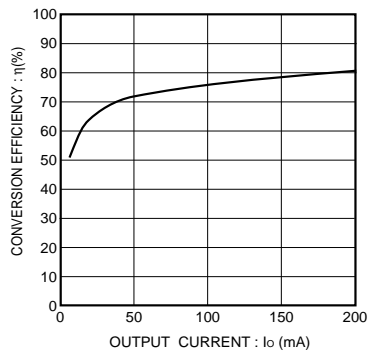

Fig.15 Conversion efficiency

Power Module

●External dimensions (Units : mm)

