

DATA SHEET

Part No.	AN18165B
Package Code No.	SSOP024-P-0300E

Contents

- Overview 3
- Features 3
- Applications 3
- Package 3
- Type 3
- Application Circuit Example (Block Diagram)..... 4
- Pin Descriptions 5
- Absolute Maximum Ratings 6
- Operating Supply Voltage Range 6
- Allowed Voltage Ranges 6

AN18165B

FM-MPX demodulation / FM noise canceller for car radio

■ Overview

AN18165B is an IC for FM-MPX demodulation for car radio and FM noise canceller.

This IC is enable to adjust and change over various function by I²C-bus, and built-in VCO reduces the number of parts.

■ Features

- I²C-bus control
- FM-MPX demodulation
- Built-in FM noise canceller (PNL)
- Built-in VCO(No cellalock required)

■ Applications

- Car radio

■ Package

- 24 pin plastic shrink small outline package (SSOP Type)

■ Type

- Silicon monolithic bipolar IC

■ Application Circuit Example / Block Diagram

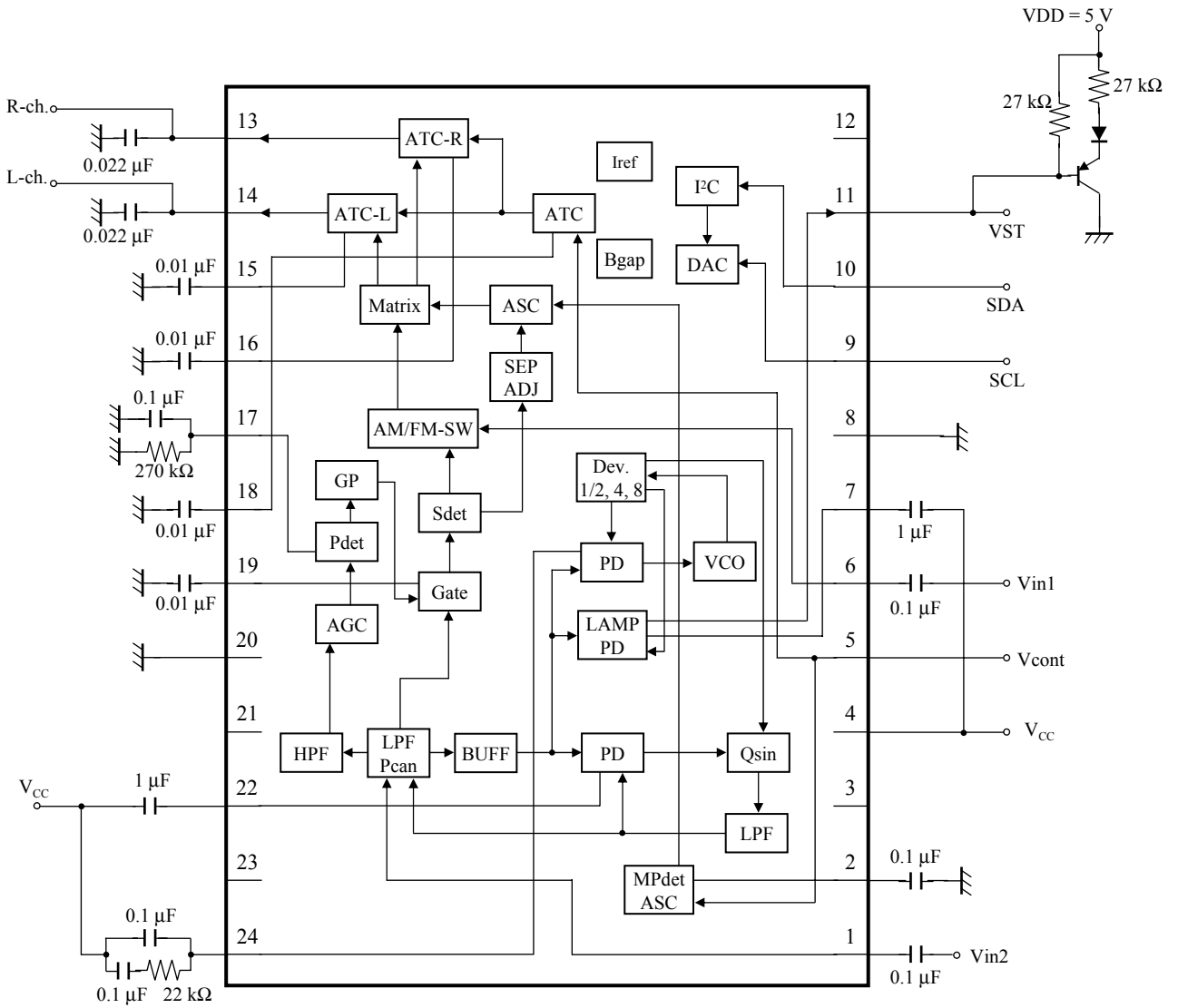

■ Pin Descriptions

Pin No.	Pin name	Type	Description
1	FMIN	Input	FM input
2	ASCTC	—	ASC time constant
3	N.C.	—	Non connected
4	VCC	Power supply	V _{CC}
5	VCONTIN	Input	FM Control voltage input
6	AMIN	Input	AM input
7	PDLPF	—	Pilot detection low-pass filter
8	VSS	Ground	VSS (Logic-GND)
9	SCL	Input	SCL
10	SDA	Input	SDA
11	STIND	Output	Stereo indicator
12	N.C.	—	Non connected
13	ROUT	Output	R-ch. output
14	LOUT	Output	L-ch. output
15	LATCLPF	—	L-ch. FM-ATC low-pass filter
16	RATCLPF	—	R-ch. FM-ATC low-pass filter
17	PNLAGC	Output	PNL AGC
18	FMATCTC	—	FM-ATC time constant
19	PNLHOLD	Output	PNL output hold
20	GND	Ground	Ground
21	N.C.	—	Non connected
22	PCLPF	—	Pilot cancellation control low-pass filter
23	N.C.	—	Non connected
24	PLLLPF	—	PLL low-pass filter

■ Absolute Maximum Ratings

A No.	Parameter	Symbol	Rating	Unit	Notes
1	Supply voltage	V_{CC}	9.1	V	*1
2	Supply current	I_{CC}	28	mA	—
3	Power dissipation	P_D	156	mW	*2
4	Operating ambient temperature	T_{opr}	-40 to +85	°C	*3
5	Storage temperature	T_{stg}	-55 to +125	°C	*3

Notes) *1: The values under the condition not exceeding the above absolute maximum ratings and the power dissipation.

*2: The power dissipation shown is the value at $T_a = 85^\circ\text{C}$ for the independent (unmounted) IC package without a heat sink.

*3: Except for the power dissipation, operating ambient temperature, and storage temperature, all ratings are for $T_a = 25^\circ\text{C}$.

■ Operating supply voltage range

Parameter	Symbol	Range	Unit	Notes
Supply voltage range	V_{CC}	7.2 to 9.0	V	*

Note) *: The values under the condition not exceeding the above absolute maximum ratings and the power dissipation.

■ Allowable Voltage Ranges

Pin No.	Pin name	Range	Unit	Notes
4	V_{CC}	0 to 9.0	V	—
5	VCONTIN	0 to 5.5	V	—
9	SCL	0 to 5.5	V	—
10	SDA	0 to 5.5	V	—
11	STIND	0 to 5.5	V	—

Note) 1. The ranges on the list are the voltages of respective pins in relation to GND.

The GND represents the voltage of GND and VSS. And $\text{GND}=\text{VSS}$.

2. Do not apply the voltages or the currents from external into the pins which are not on the list.

Request for your special attention and precautions in using the technical information and semiconductors described in this book

- (1) If any of the products or technical information described in this book is to be exported or provided to non-residents, the laws and regulations of the exporting country, especially, those with regard to security export control, must be observed.
- (2) The technical information described in this book is intended only to show the main characteristics and application circuit examples of the products, and no license is granted under any intellectual property right or other right owned by our company or any other company. Therefore, no responsibility is assumed by our company as to the infringement upon any such right owned by any other company which may arise as a result of the use of technical information described in this book.
- (3) The products described in this book are intended to be used for standard applications or general electronic equipment (such as office equipment, communications equipment, measuring instruments and household appliances).
Consult our sales staff in advance for information on the following applications:
 - Special applications (such as for airplanes, aerospace, automobiles, traffic control equipment, combustion equipment, life support systems and safety devices) in which exceptional quality and reliability are required, or if the failure or malfunction of the products may directly jeopardize life or harm the human body.
 - Any applications other than the standard applications intended.
- (4) The products and product specifications described in this book are subject to change without notice for modification and/or improvement. At the final stage of your design, purchasing, or use of the products, therefore, ask for the most up-to-date Product Standards in advance to make sure that the latest specifications satisfy your requirements.
- (5) When designing your equipment, comply with the range of absolute maximum rating and the guaranteed operating conditions (operating power supply voltage and operating environment etc.). Especially, please be careful not to exceed the range of absolute maximum rating on the transient state, such as power-on, power-off and mode-switching. Otherwise, we will not be liable for any defect which may arise later in your equipment.
 - Even when the products are used within the guaranteed values, take into the consideration of incidence of break down and failure mode, possible to occur to semiconductor products. Measures on the systems such as redundant design, arresting the spread of fire or preventing glitch are recommended in order to prevent physical injury, fire, social damages, for example, by using the products.
- (6) Comply with the instructions for use in order to prevent breakdown and characteristics change due to external factors (ESD, EOS, thermal stress and mechanical stress) at the time of handling, mounting or at customer's process. When using products for which damp-proof packing is required, satisfy the conditions, such as shelf life and the elapsed time since first opening the packages.
- (7) This book may be not reprinted or reproduced whether wholly or partially, without the prior written permission of Matsushita Electric Industrial Co., Ltd.