



CR6202

Switching Power Supply Controller ICs

Features

- Set-in high-voltage power switch transistor of 700V and few peripheral components
- With the modulation of lock pulse width, the testing is according to the pulse limit current.
- With the function of output frequency reduction, the non-output power consumption can be less than 0.25W.
- Inner-built ramp and anti-feedback compensation function
- The independent upper-limit current testing controller deals with over-current and over-load of the controller real-timely.
- The period emission pole is turned off and it outputs by deflected voltage, and the pressure resistance of the power transistor is improved.
- Set-in current limit resistance with temperature compensation, which makes the current limit precise
- Set-in heat protection circuit
- Startup is accomplished with the magnification function of the switch power transistor, and the power consumption of startup resistance is reduced more than 10 times.
- Few peripheral components
- Low startup and operating current
- VCC over-voltage automatic limit
- Wide-voltage output power up to 5W, and the narrow-voltage output power up to 8W.
- Pb-Free DIP-8L Package

General Description

CR6202 is a high-performance current mode flyback PWM controller for AC/DC transformer with high performance and price ratio, which supplies continuous output power of 5W within the range of wide-voltage between 85V and 265V, the output power of peak value can be up to 18W. The combination of optimized reasonable circuit design and bipolar factory technology with high performance and price ratio economizes the whole cost ultimately. The power controller can be applied to the typical flyback circuit topology so as to form a simple AC/DC transformer. The startup circuit inside IC is designed as a particular current inhalation way, so it can start up with the magnification function of the power switch transistor itself, which lessens the power consumption for starting the resistance remarkably; when the output power is lower, IC will reduce the working frequency automatically, therefore, the standby power consumption becomes extremely low. When the power transistor is closed, the interior circuit will

bias it reversely, utilize the characteristic of high pressure resistance CB of bipolar transistor directly, and improve its pressure resistance capacity to the high voltage of 700V, which ensures the security of the power transistor.

Meanwhile, the perfect function of overload and saturation prevention is provided inside of IC, which can keep away some abnormal status, such as overload, saturation of transformer, and output short circuit, so as to improve the reliability of the power supply. Besides, there is a 2.5V voltage reference integrated inside IC for providing precise voltage to the clock circuit, and clock frequency can be set up by an exterior timing capacity. Now the standard encapsulation and the environmental protection leadless encapsulation that meets European standard of DIP-8L are supplied.

Typical Application Circuit

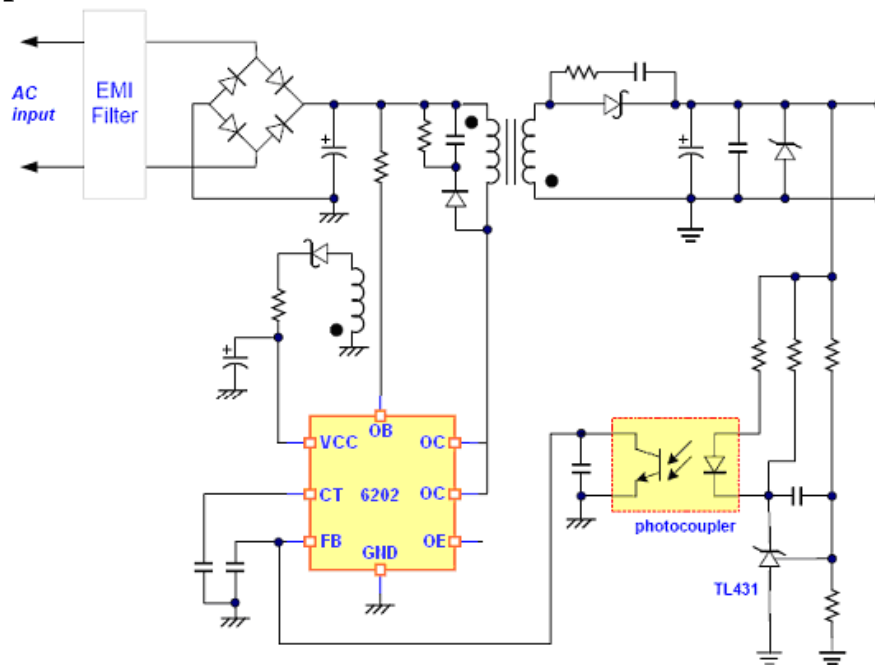

Absolute Maximum Ratings

Symbol	Parameter	Rating	Unit
V_{CC}	Power Supply voltage	16	V
V_{ST}	Startup input voltage	16	V
V_{PIN}	Pins input voltage	$V_{CC}+0.3V$	V
V_{OC_Max}	Endurance voltage of OC collector	-0.3 to 700V	V
I_{SW_Max}	Switching current of peak value	300	mA
P_D	Total dissipation power	1000	mW
	ESD Capability, HBM Model	3000	V
T_L	Lead Temperature (Soldering) @DIP-8 (10S)	260	°C
T_{OP}	Operating temperature range	0 to +125	°C
T_{STG}	Storage Temperature Range	-55 to +150	°C

CR6202

Pin Assignment & Description

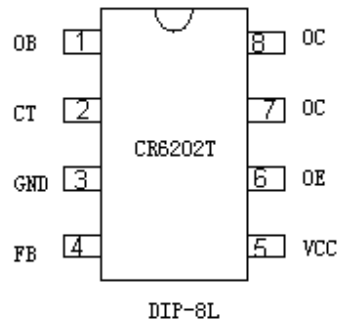

Name	Description
CT	By connecting a cap to ground to set the switching frequency
FB	Feedback pin
GND	GND
OC	Power Transistor collector drive output and start-up current input.
OE	No connected
OB	Power Transistor Base drive output and start-up current control.
VCC	Power Supply.

Block Diagram

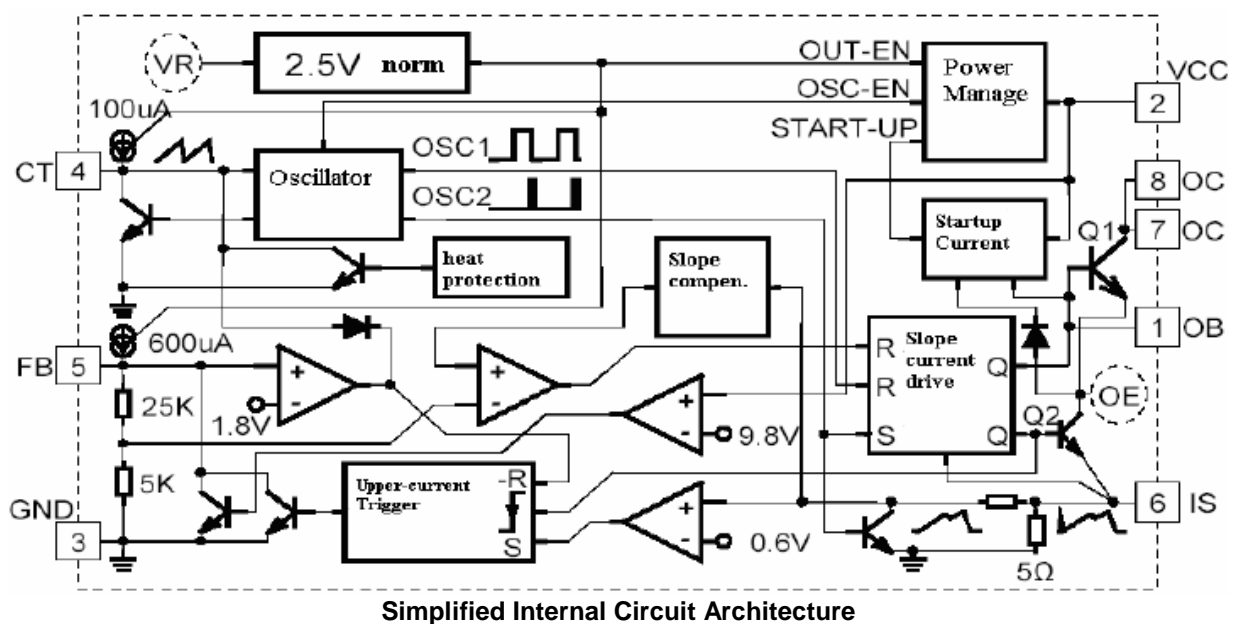

CR6202**RECOMMENDED OPERATION CONDITION**

Item	Min.	Typ.	Max.	Unit
Power supply voltage, V _{CC}	4.8	5.5	9.0	V
Pins input voltage	-0.3	-	V _{CC}	V
Reverse voltage of peak value	-	-	500	V
Switching current of peak value	-	-	250	mA
Timing capacitance	270	330	680	pF
Oscillating frequency	32	66	81	kHz
Operating temperature	0		70	°C

Electrical Characteristics (Ta=25°C, V_{CC}=5.5-7.5V, Ct=330PF)**Output**

Item	Testing condition	Min.	Typ.	Max.	Unit
Maximum pressure resistance of switching transistor	I _{oc} =10mA	700	-	-	V
on-saturation pressure drop	I _{oc} =250mA	-	-	1	V
Output rise-time	CL=1nF	-	-	75	ns
Output fall-time	CL=1nF	-	-	75	ns
Output limit current	T _j =0-100°C	250	270	290	mA
OE clamp voltage	OE=0.001-0.29A	-	1.5	-	V

Reference

Item	Testing condition	Min.	Typ.	Max.	Unit
Reference output voltage	I _o =1.0mA	2.4	2.5	2.6	V
Power Regulation	V _{CC} =5.5-9V	-	2	20	mV
Load Regulation	I _o =0.1-1.2mA	-	-	3	%
Temperature stability		-	0.2	-	mV/°C
Output noise voltage	F=10Hz-10KHz	-	-	50	μV
Long-term stability	1000h @ T=85°C	-	5	-	mV

Oscillator

Item	Testing condition	Min.	Typ.	Max.	Unit
Oscillating frequency	C _t =330PF	59	66	73	KHz
Frequency change ratio with	V _{CC} =5.5-9V	-	-	1	%

CR6202

voltage					
Frequency change ratio with temperature	Ta=0-85°C	-	-	1	%
Vibration amplitude of oscillator (Vp-p)		-	2.4	-	V
Drop edge of oscillator	Ct=330PF	-	900	-	ns

Feedback

Item	Testing condition	Min.	Typ.	Max.	Unit
Pull-up current	Ct=330PF	-	0.50	0.60	mA
pull-down resistance	Vcc=5.5-9V	-	23	-	KΩ
Power supply rejection ratio	Vcc=5.5-9V	-	60	70	dB

Current sampling

Item	Testing condition	Min.	Typ.	Max.	Unit
Current sampling limit		0.55	0.60	0.65	V
upper limit current prevention		0.25	0.27	0.29	A
Power supply rejection ratio		-	60	70	dB
transmission delay		-	150	250	ns

Pulse Width Modulation

Item	Testing condition	Min.	Typ.	Max.	Unit
Maximum duty cycle		55	57	65	%
Minimum duty cycle		-	-	3.5	%

Power Supply current

Item	Testing condition	Min.	Typ.	Max.	Unit
Startup acceptance current		1.6	2.4	3.2	mA
Startup static current		-	50	80	μA
Static current	Vcc=8V	-	3.0	-	mA
Startup voltage		8.5	9.0	9.8	V
Close voltage of oscillator		4.0	4.4	4.6	V
Restart voltage		-	3.6	-	V
Over-voltage limit margin		10.0	10.8	12.0	V

CR6202

Operation description

- Initially, after power up, FB pull-up current source is turn off. OC inputs start-up current from power transistor to VCC. OB controls the base current of power transistor and limits the collector current (start-up accept current of CR6202) of power transistor so to safeguard the power transistor. When the VCC voltage rises to 10.2V, the start-up phase completes and goes to the normal operation.
- In normal operation, VCC voltage must keep 4.8~9V,FB pull-up current source turns on. Oscillator outputs OSC1 to decide the maximum duty cycle and OSC2 to trigger power supply entering the open cycle and cover spike value of power transistor start-up current. If FB is less than 1.8V(about 1.2-1.8V), the less the FB is, the wider the oscillation cycle is. (This characteristics reduces the standby consumption of the switching power supply) . If external feedback intends to get VCC greater than 11.4V, the internal feedback circuit regular VCC on 11.4V. (Making use of this characteristics to stable output voltage no using external feedback circuit, but the regulating is not precise) .

In open cycle, OB provides the base current for power transistor, OE pulls down the emitter of power transistor to IS and OB adopts slop current drive (OB open current is IS function, when IS=0V,OB open current is about 24mA, and OB open current is increasing with IS linear increasing. When IS increases 0.6V, OB open current is about 40mA. This characteristics makes use of output current of OB effectively and reduces power consumption of CR6202). If IS detects the FB designated current, it enters closed cycle. In closed cycle, OB pulls down, the power transistor is not be turn off immediately but OE clamps 1.5V (after power transistor is turn off, the base is reverse bias, the breakdown voltage of power transistor is improved). In the open or closed cycle, if power transistor is detected to exceed upper limit current, the upper limit current trigger will set firstly and forces FB to pull down, duty cycle reduced, so to protect power transistor and transformer. In the next closed cycle start-up time, or when FB is less than 1.8V, upper current trigger resets. In addition, CR6202 is built in thermal protection, when the internal temperature is above 125°C, it will widen the cycle of oscillator, so that the temperature of CR6202 will not exceed 135°C. Slop compensation is built in to stabilization open/closed cycle during the maximum duty cycle or the continual current mode of CR6202.

- If VCC reduces to 4.4V, oscillator is turn off, OSC1 OSC2 low level, power supply keeps closed cycle. when VCC continually reduces to about 3.6 V , CR6202 enters start-up phase again.

Definition of Electric Parameter

- Start-up acceptance current: the current on OC when OB inputs 0.5mA during the start-up phase
- Start-up Quiescent Current: the current of minimum current source that can make VCC oscillate (namely finish the start-up of CR6202) when VCC meets filter capacitance and adjustable current source, CT meets 330PF, and other pins no connected.
- Start-up Voltage: Maximum VCC value of above VCC oscillation.
- Re-start Voltage: Minimum VCC value of above VCC oscillation.

CR6202

- Close Voltage of Oscillator: VCC value that makes RC oscillator stop oscillating when the above VCC oscillates the falling edge.
- Quiescent Current: VCC power current when FB is grounded with 1.0Kohm of resistance at normal phase.
- Pull-up/pull-down Current of the Oscillator: at normal phase, FB is 2.5V, CT is 1.25V, and CT is in pull-up/pull-down current.
- FB Pull-up Current: Pull-up current on FB at normal phase when FB is 2.5V, IS is 0V.
- FB Upper Limit Current Prevention: The pull-down current on FB at normal phase when FB is 6V, IS is 0.3V.
- Internal Feedback Power Voltage: VCC value of CR6202 power supply of the circuit without peripheral standby at normal phase
- OC Upper Limit Voltage: the minimum OC current of pull-down current on FB when FB is 6V
- Ramp current drive: it refers to the power tube base drive OB on-current is the function of IS, when IS is 0V, on-current OB is about 24mA, then on-current OB will increase linearly with IS, when IS is increased to 0.6V, on-current OE is about 40mA.

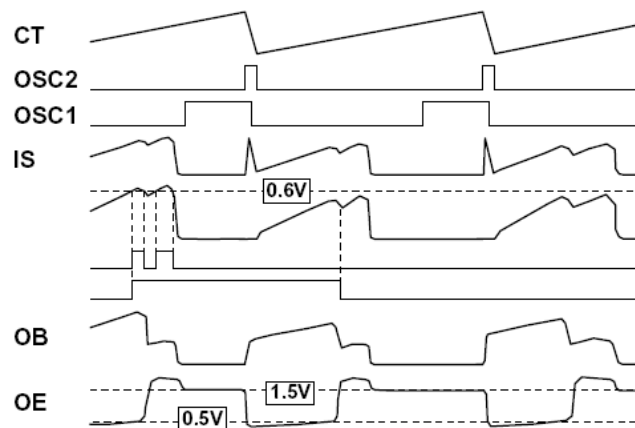

Fig.1 OPEN/CLOSED CYCLE WAVES IN NORMAL OPERATION

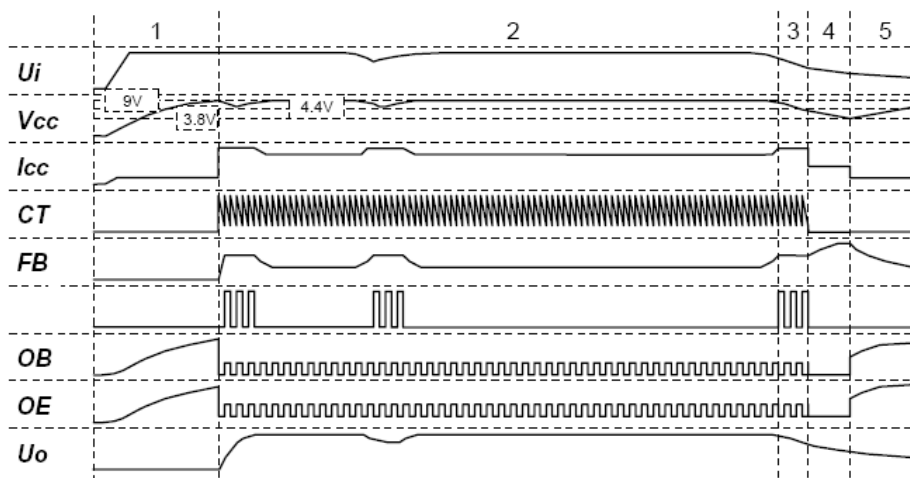

Fig.2 OVERALL SIGNAL WAVEFORMS OF CR6202

CR6202

Application Information

1. Relationship between CT timing capacitance and switching frequency

CT capacitance is charged by 50uA constant current through internal current source to form the rise-up edge, when the voltage is charged to 1.6V, the internal circuit will discharge CT with 1.9mA of pull-down current to form the fall-down edge of the clock, and accomplish a clock cycle, which is about:

$$T=CT*48000 (S)$$

$$Fs=1/T (Hz)$$

Although the bipolar circuit can work under higher frequency, but for the switch of bipolar power, the influence caused by switch loss for the storage time is still be considered. Generally, the appropriate switching frequency is about below 70KHz. Under common application situation, CT capacitance of CR6202 can be configured by 330PF, when the relevant working frequency is around 66KHz.

2. FB feedback and control

In normal working state, the voltage of FB will decide the value of the maximum switching current, the higher the voltage is, the bigger the switching current is (it is only limited at the peak value). FB pins pull up 600uA power source internally, the pull-down resistance is about 23K Ω (it approximates the equivalent value). In addition, when FB voltage is less than 1.8V, the oscillating cycle will be enlarged, the switching frequency will declined, the more it is less than 1.8V, the lower the switching frequency is. The external FB capacitance will influence the feedback bandwidth, so some external parameters will be affected, such as transient-state characteristic.

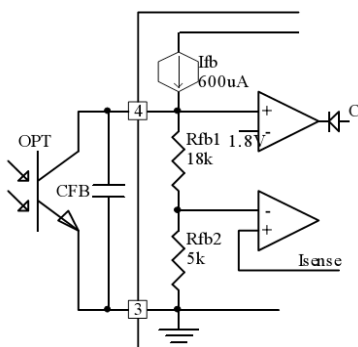

As for the value of CFB capacitance, the typical application can be selected according to the frequency character of feedback circuit between 10nF and 100nF. It is recommended to use 22nF.

3. Over temperature protection

The interior of IC integrates the function of over temperature protection. When the internal temperature of the chip reaches 125°C, the over-heat protection circuit will work, it will pull down the clock signal, the switching frequency will fall until the oscillator is turned off. As shown in the following figure

CR6202

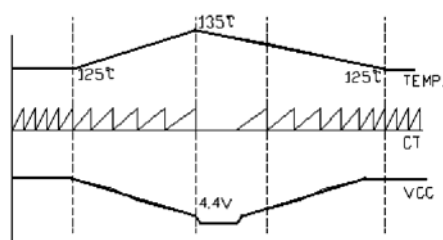

4. Driving characteristic and high voltage endurance bias technology of power tube

The power tube adopts the ramp current drive, the driving current will increase with the output power, when FB is 0, the current of OB is about 24mA, when FB is 6V, the current of OB is about 40mA, and the driving power consumption will decrease remarkably when the output is low.

The interior of IC integrates the particular bias technology, when the power tube is shut, the output of OB will be pulled down to the ground, meanwhile, it will bias the output of OE to 1.5V or so, bias the emitter junction, accelerate the decreasing speed of Ic current, expand the effective safe working area, the switching tube affords the reverse voltage CB, therefore, the endurance characteristic of the switching tube can be up to 700V. For more detail information for the voltage endurance characteristic of the switching tube, please refer to the relevant technical data.

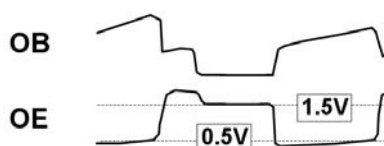

5. Over-voltage and under-voltage protection

IC has the function of slow-moving under-voltage protection, when the voltage of VCC reaches 8.8V, IC will set out to start, the initial start-up voltage is provided by the driving resistance, the high voltage of input will be injected into the base of the switching tube through Ic current, consequently, the driving voltage is formed. When IC works normally, the voltage of VCC should be keep between 4.8V and 9V (including the situation of full load output), if the voltage of VCC falls to 4.2V, the oscillator will enter the state of shutoff, when it decreases to 3.6V further, IC will begin to reset. As shown in the following figure:

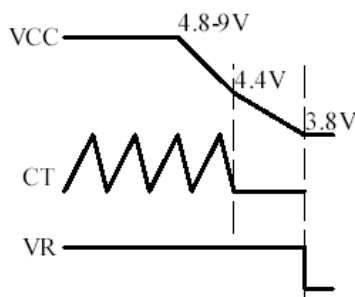

VCC in side IC is provided with a comparator controller of the upper limit voltage, if VCC tries to be more than 10V, the comparator will work, FB will be pulled down, and it will lock VCC to 10V, and reach the limit

CR6202

function of over voltage, by which the voltage feedback function of the front terminal can be accomplished conveniently, the rising phenomenon of the output voltage in large extent can be avoided when the open-loop is output, so as to guarantee the security of the load. Because of the existence of this characteristic, the design of VCC shall be kept at the proper range, so as to avoid VCC rising excessively high when the output is high, and make the output voltage escape from decreasing when IC over-voltage limit works.

6. Maximum switching current limit

IC has the function of current limit cycle by cycle. It will test every switching current in every switching cycle, if the current fixed by FB or upper limit current prevention is reached, it will come into the close cycle, and the detection of the current has the function of real-time foreland hide, it can shield the switching peak, and avoid the wrong detection of the switching current. Then the reasonable temperature compensation eliminates the influence of temperature, comparing with normal MOSFET (the alteration of R_{on} will be large when the temperature changes) switching chip, the switching current can always be very accurate in a larger range, thus not too much allowance is needed to match a larger working temperature range for the designer when he designs the scenario, and the security of the circuit for use can be improved.

The typical maximum limit value of switching current for CR6202 is 0.25A. When designing a flyback power with 80V of emitter voltage, it can accomplish the output power of more than 5W easily, and meet the broad temperature range.

7. Requirement of heat elimination

As for a typical power switch, it must have necessary heat elimination measures, so as to avoid that the excessive heat leads to heat protection. The primary heat inside IC is produced by the on-off wasting of the switching tube, so appropriate heat elimination position is Pin7-8 pin of IC, one wiely way is to pave PCB copper foil of a certain area on Pin7-8 pin, what's more, plating tin on the copper foil will improve the heat elimination ability greatly. For an input of 85-265V, the typical application of 5W output and 100mm² copper foil are necessary.

CR6202

CR6202_5V1A FLYBACK POWER

SCHEMATIC

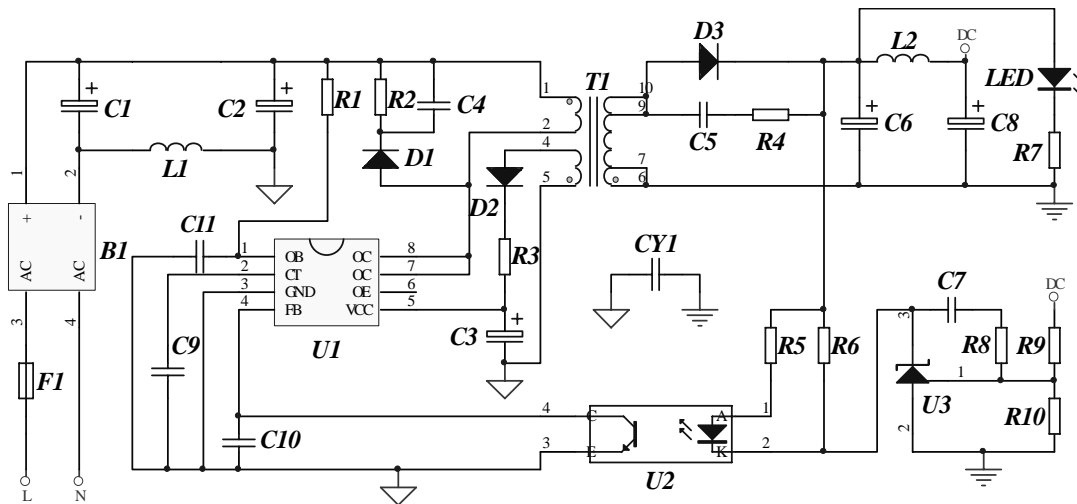

PCB LAYOUT:

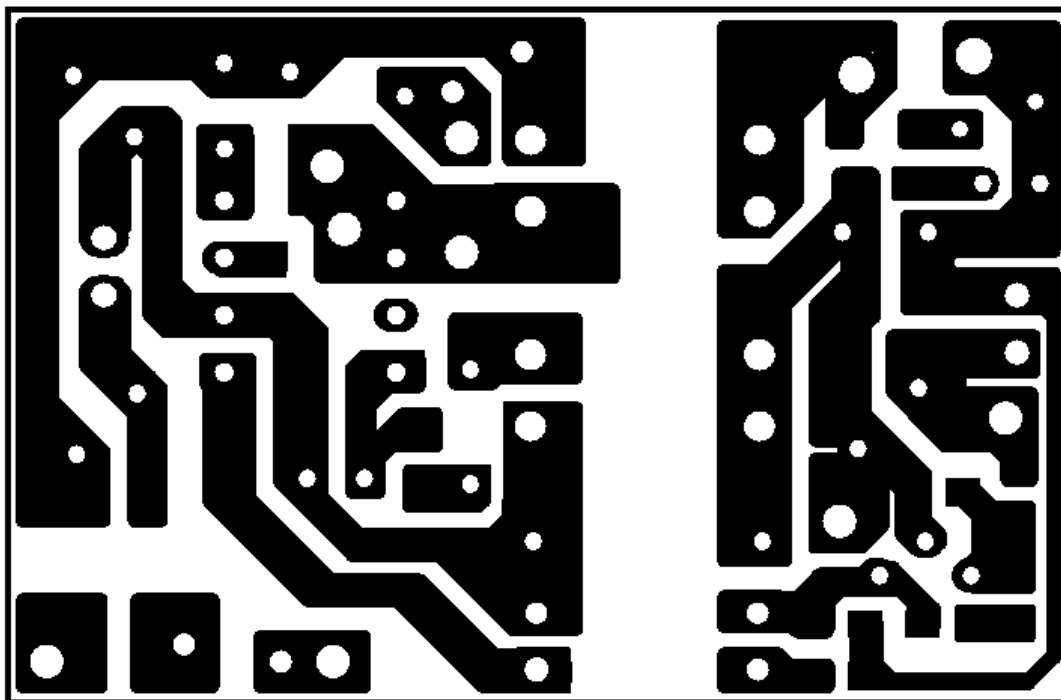

PCB Layout

CR6202

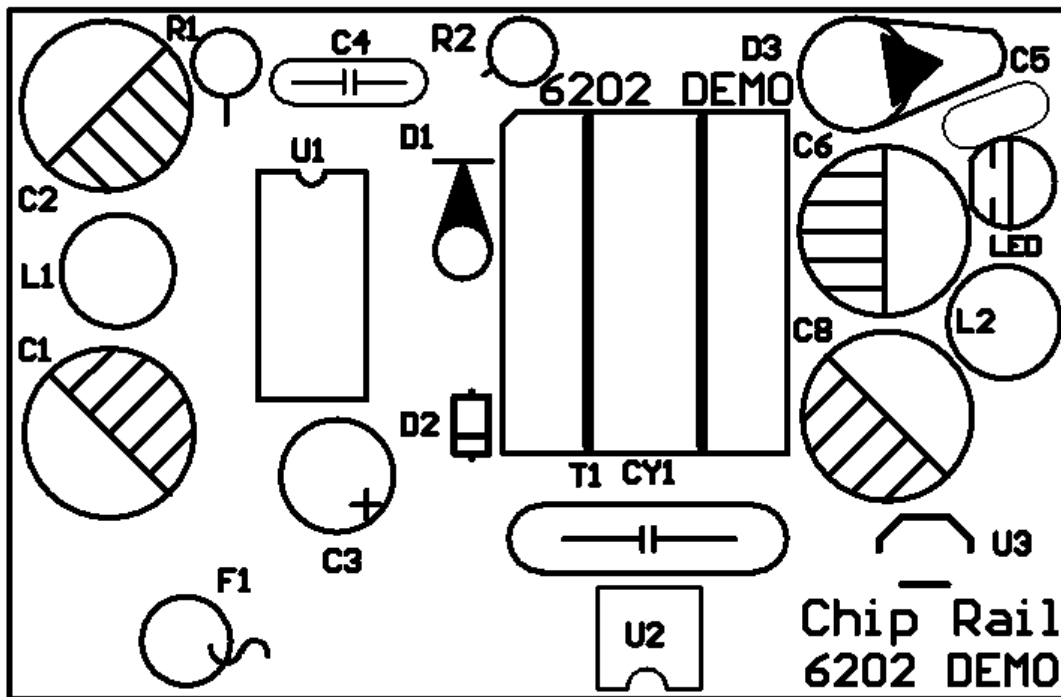

PCB Top Overlay

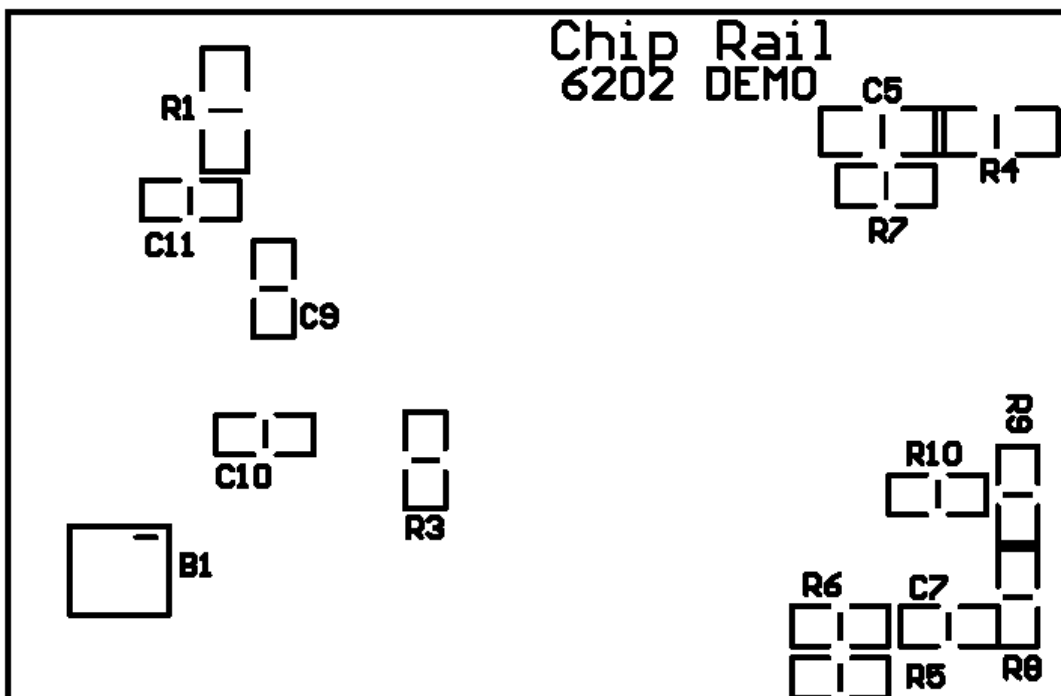

PCB Bottom Overlay

CR6202**BOM List:****BOM**

DESIGNATOR	DESCRIPTION	NOTE	DESIGNATOR	DESCRIPTION	NOTE
B1	1A600V	BRIGE	F1	1A/250V	FUSE
C1	4.7uF	C/C;DIP;+/-10%;PINTCH=110MIL	L1	330uH	Φ6*8
C2	4.7uF	C/C;DIP;+/-10%;PINTCH=110MIL	L2	10uH	Φ6*9/1A
C3	22uF/50V	Φ5*12	T1	EE16	EE16
C4	103/1KV	C/C;DIP;+/-10%;PINTCH=200MIL	R1	2.2M	RES;SMD;1206;+/-5%
C5	102/100V	1206	R2	100K	RES;MOF;+/-3%;1W
C6	470uF/25V	C/C;DIP;+/-10%;PINTCH=110MIL	R3	4.7Ω	RES;SMD;0805;+/-5%
C7	104/25V	0805	R4	20Ω	RES;SMD;1206;+/-5%
C8	330uF/25V	C/C;DIP;+/-10%;PINTCH=110MIL	R5	100Ω	RES;SMD;0805;+/-5%
C9	330pF	0805	R6	2.2K	RES;SMD;0805;+/-5%
C10	103	0805	R7	3.3K	RES;SMD;0805;+/-5%
C11	102	0805	R8	10K	RES;SMD;0805;+/-5%
CY1	222/400V	C/Y1;+/-20%;PINTCH=400MIL;	R9	10K	RES;SMD;0805;+/-5%
D1	FR107	DIODE	U1	CR6202	DIP8
D2	1N4148	DIODE	U2	PC817B	DIP4
D3	1N5822	DIODE	U3	TL431A	T092
D5	LED	Φ3MM			

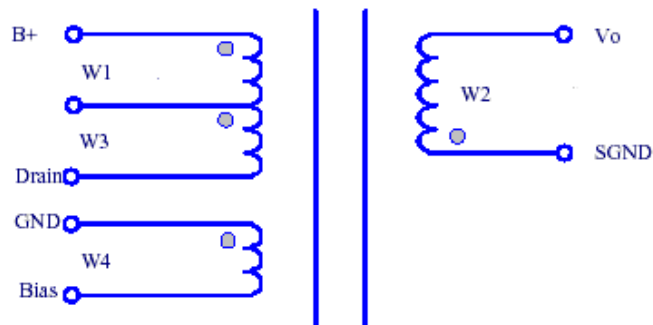
Transformer:

Core & Bobbin	WINDING	WIRE GAUGE(MM)	TURNS
EE16	W1	0.18*1	75
	W2	0.51*1	11
	W3	0.18*1	75
	W4	0.18*1	14

NOTE: N1(W1+W3) INDUCTANCE=3MH

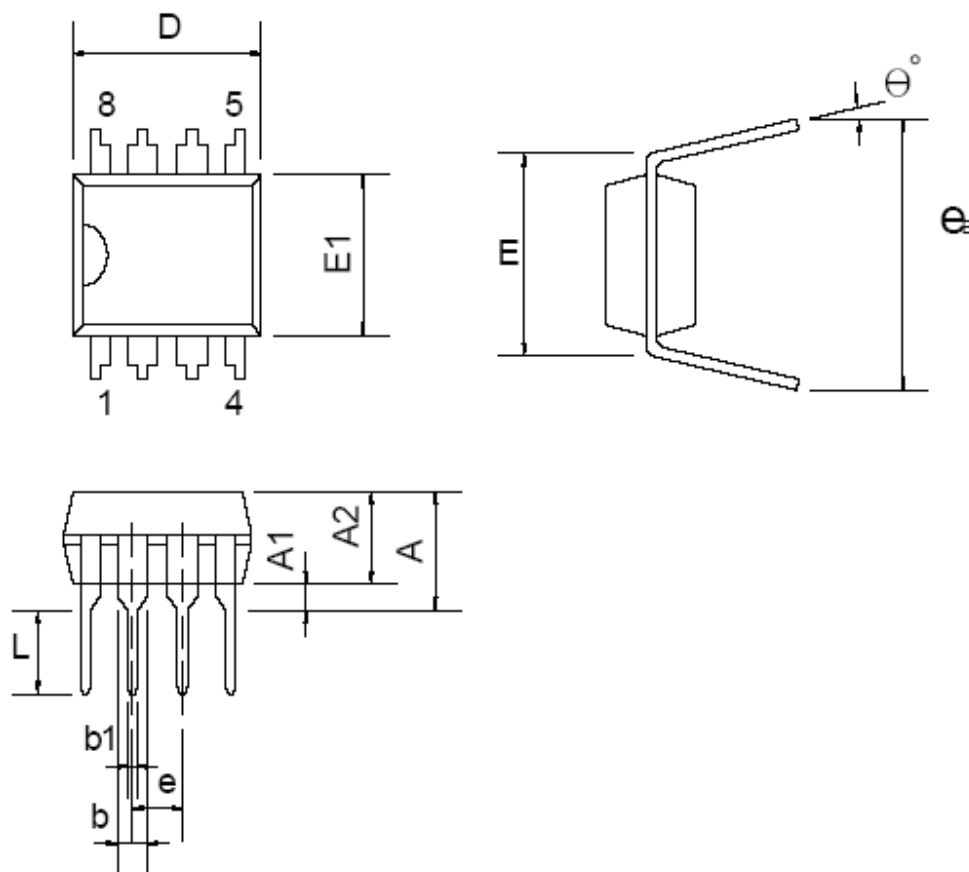
CR6202**PACKAGE INFORMATION****DIP-8****Dimensions**

Symbol	Millimeters			Inches		
	Min.	Typ.	Max.	Min.	Typ.	Max.
A			5.334			0.210
A1	0.381			0.015		
A2	3.175	3.302	3.429	0.125	0.130	0.135
b		1.524			0.060	
b1		0.457			0.018	
D	9.017	9.271	10.160	0.355	0.365	0.400
E		7.620			0.300	
E1	6.223	6.350	6.477	0.245	0.250	0.255
e		2.540			0.100	
L	2.921	3.302	3.810	0.115	0.130	0.150
eB	8.509	9.017	9.525	0.335	0.355	0.375
θ°	0°	7°	15°	0°	7°	15°