

## Features

- Operating voltage:
  - 2.4V~5V for the HT12A/B/C
  - 2.4V~12V for the HT12E/EA
- Low power and high noise immunity CMOS technology
- Low stand-by current
- Minimum transmission word:
  - Four words for the HT12E/EA
  - One word for the HT12A/B/C
- A built-in oscillator with only a 5% resistor
- HT12A/B/C with a 38KHz carrier for Infra-Red transmission medium
- Data code polarity:
  - HT12A/C/E/EA: Positive polarity
  - HT12B: Negative polarity
- Minimal external components

## Applications

- Burglar alarm system
- Smoke and fire alarm system
- Garage door controllers
- Car door controllers
- Car alarm system
- Security system
- Cordless telephones
- Other remote control systems

## General Description

The 2<sup>12</sup> encoders are a series of CMOS LSIs for remote control system applications. They are capable of encoding information which consists of N address bits and 12-N data bits. Each address/data input can be set to one of the two logic states. The programmed addresses/data are transmitted together with the header bits

via an RF or an Infra-Red transmission medium upon receipt of a trigger signal. The capability to select a  $\overline{TE}$  trigger on the HT12E/EA or a DATA trigger on the HT12A/B/C further enhances the application flexibility of the 2<sup>12</sup> series of encoders. The HT12A/B/C additionally provides a 38KHz carrier for Infra-Red systems.

## Selection Table

Function Item	Address No.	Address/Data No.	Data No.	Oscillator	Trigger	Package	Carrier Output	Negative Polarity
HT12A	8	0	4	455K Hz resonator	D8~D11	18 DIP 20 SOP	38K Hz	No
HT12B	8	0	4	455K Hz resonator	D8~D11	18 DIP 20 SOP	38K Hz	Yes
HT12C	0	0	10	455K Hz resonator	D2~D11	16 DIP 16 SOP	38K Hz	No
	2					18 DIP		
HT12E/EA	8	4	0	RC oscillator	$\overline{TE}$	14/18 DIP 16/20 SOP 16 NSOP	No	No

Note: Address/Data represents pins that can be address or data according the decoder requirement.

**Block Diagram**

$\overline{TE}$  trigger

HT12E/EA

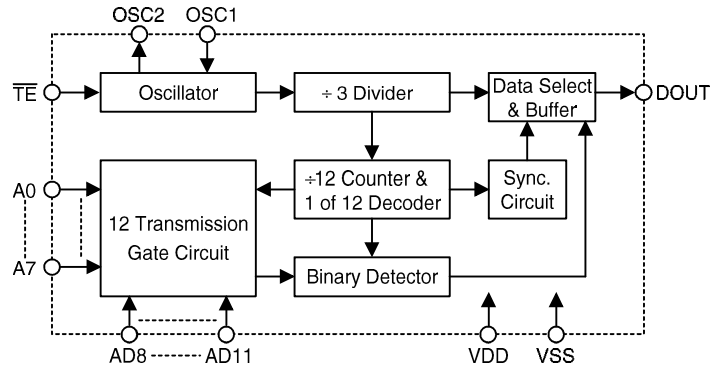

www.DataSheet4U.com

**DATA trigger**

HT12A/B/C

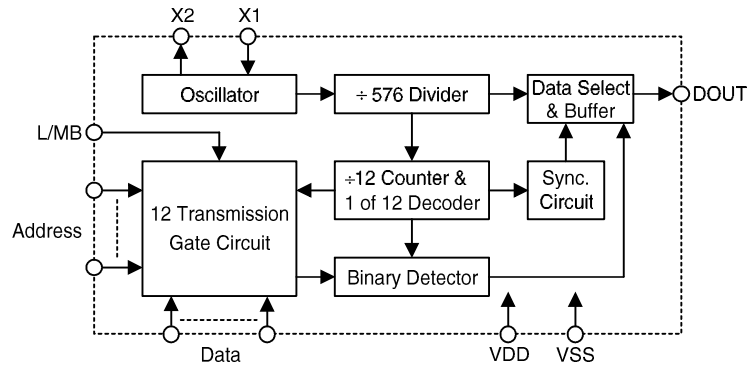

Note: The address data pins are available in various combinations (refer to the address/data table).

**Pin Description**

Pin Name	I/O	Internal Connection	Description
A0~A7	I	CMOS IN Pull-High (HT12A/B/C)	Input pins for address A0~A7 setting They can be externally set to VDD or VSS.
		NMOS TRANSMISSION GATE (HT12E)	
		NMOS TRANSMISSION GATE PROTECTION DIODE (HT12EA)	
AD8~AD11	I	NMOS TRANSMISSION GATE (HT12E)	Input pins for address/data AD8~AD11 setting They can be externally set to VDD or VSS (only for the HT12E/EA).
		NMOS TRANSMISSION GATE PROTECTION DIODE (HT12EA)	
D2~D11	I	CMOS IN Pull-High	Input pins for data D2~D11 setting and transmission enable, active low They can be externally set to VSS or left open (see Note).
DOUT	O	CMOS OUT	Encoder data serial transmission output
L/MB	I	CMOS IN Pull-High	Latch/Momentary transmission format selection pin: Latch: Floating or VDD Momentary: VSS
$\overline{TE}$	I	CMOS IN Pull-High	Transmission enable, active low (see Note).
OSC1	I	OSCILLATOR 1	Oscillator input pin
OSC2	O	OSCILLATOR 1	Oscillator output pin
X1	I	OSCILLATOR 2	455KHz resonator oscillator input
X2	O	OSCILLATOR 2	455KHz resonator oscillator output
VSS	I	—	Negative power supply (GND)
VDD	I	—	Positive power supply

Note: D2~D11 are all data input and transmission enable pins of the HT12A/B/C.

$\overline{TE}$  is a transmission enable pin of the HT12E/EA.

**Approximate internal connection circuits**

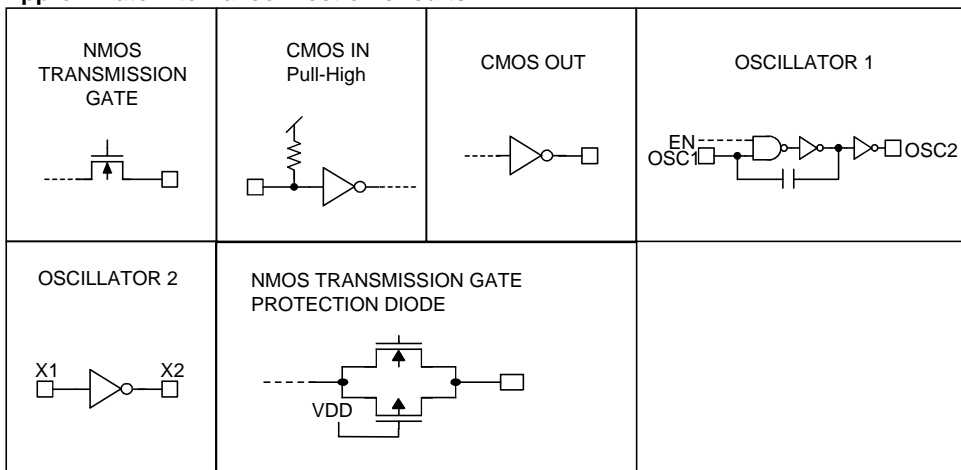

www.DataSheet4U.com

**Absolute Maximum Ratings**

Supply Voltage (HT12A/B/C) ..... -0.3V to 5.5V      Supply Voltage (HT12E/EA) ..... -0.3V to 13V  
 Input Voltage..... V<sub>SS</sub>-0.3 to V<sub>DD</sub>+0.3V      Storage Temperature..... -50°C to 125°C  
 Operating Temperature..... -20°C to 75°C

**Electrical Characteristics**

HT12A/B/C

(T<sub>a</sub>=25°C)

Symbol	Parameter	Test Condition		Min.	Typ.	Max.	Unit
		V <sub>DD</sub>	Condition				
V <sub>DD</sub>	Operating Voltage	—	—	2.4	3	5	V
I <sub>STB</sub>	Stand-by Current	3V	Oscillator stops.	—	0.1	1	μA
		5V		—	0.1	1	μA
I <sub>DD</sub>	Operating Current	3V	No load F <sub>OSC</sub> =455KHz	—	200	400	μA
		5V		—	400	800	μA
I <sub>DOUT</sub>	Output Drive Current	5V	V <sub>OH</sub> =0.9V <sub>DD</sub> (Source)	-1	-1.6	—	mA
			V <sub>OL</sub> =0.1V <sub>DD</sub> (Sink)	2	3.2	—	mA
V <sub>IH</sub>	"H" Input Voltage	—	—	0.8V <sub>DD</sub>	—	V <sub>DD</sub>	V
V <sub>IL</sub>	"L" Input Voltage	—	—	0	—	0.2V <sub>DD</sub>	V
R <sub>DATA</sub>	D2~D11 Pull-High Resistance	5V	V <sub>DATA</sub> =0V	—	150	300	KΩ

**HT12E**

(Ta=25°C)

Symbol	Parameter	Test Condition		Min.	Typ.	Max.	Unit
		V <sub>DD</sub>	Condition				
V <sub>DD</sub>	Operating Voltage	—	—	2.4	5	12	V
I <sub>STB</sub>	Stand-by Current	3V	Oscillator stops.	—	0.1	1	μA
		12V		—	2	4	μA
I <sub>DD</sub>	Operating Current	3V	No load F <sub>OSC</sub> =3KHz	—	40	80	μA
		12V		—	150	300	μA
I <sub>DOUT</sub>	Output Drive Current	5V	V <sub>OH</sub> =0.9V <sub>DD</sub> (Source)	-1	-1.6	—	mA
			V <sub>OL</sub> =0.1V <sub>DD</sub> (Sink)	1	1.6	—	mA
V <sub>IH</sub>	"H" Input Voltage	—	—	0.8V <sub>DD</sub>	—	V <sub>DD</sub>	V
V <sub>IL</sub>	"L" Input Voltage	—	—	0	—	0.2V <sub>DD</sub>	V
F <sub>OSC</sub>	Oscillator Frequency	5V	R <sub>OSC</sub> =1.1MΩ	—	3	—	KHz
R <sub>TE</sub>	$\overline{\text{TE}}$ Pull-High Resistance	5V	V <sub>TE</sub> =0V	—	1.5	3	MΩ

www.DataSheet4U.com

**Functional Description**

**Operation**

The 2<sup>12</sup> series of encoders begins a 4 word transmission cycle upon receipt of a transmission enable ( $\overline{TE}$  for the HT12E/EA or D2~D11 for the HT12A/B/C, active low). This cycle will repeat itself as long as the transmission enable ( $\overline{TE}$  or D2~D11) is held low. Once the transmission enable returns high the encoder output completes its final cycle and then stops as shown in Fig.1 for the HT12E/EA and in Fig.2,3 for the HT12A/B/C.

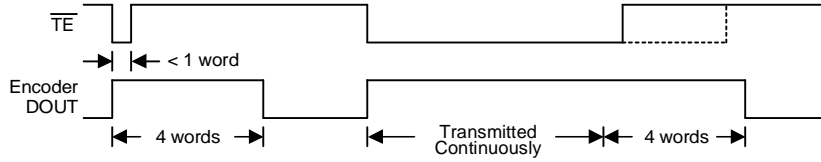

Fig.1 Transmission timing for the HT12E/EA

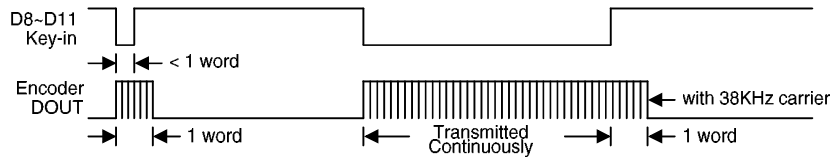

Fig.2 Transmission timing for the HT12A/B/C (L/MB=Floating or VDD)

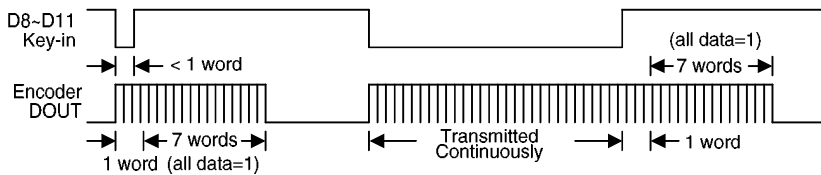

Fig.3 Transmission timing for the HT12A/B/C (L/MB=VSS)

**Information word**

L/MB is the Latch/Momentary type selection pin. If L/MB=1 the device is in the latch mode (for use with the latch type of data decoders). When the transmission enable is removed during a transmission, the DOUT pin outputs a complete word and then stops. On the other hand, if L/MB=0 the device is in the momentary mode (for use with the momentary type of data decoders). When the transmission enable is removed during a transmission, the DOUT outputs a complete word and then adds 7 words all with the "1" data code.

An information word consists of 3 periods as illustrated in Fig.4.

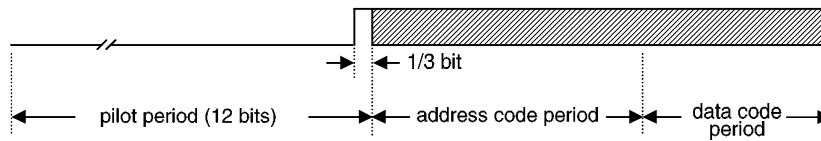

Fig.4 Composition of information

**Address/data waveform**

Each programmable address/data pin can be externally set to one of the following two logic states as shown in Fig.5 (for the HT12E/EA) and Fig.6,7 (for the HT12A/B/C):

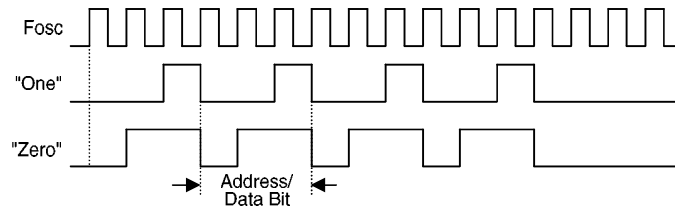

Fig.5 Address/Data bit waveform for the HT12E/EA

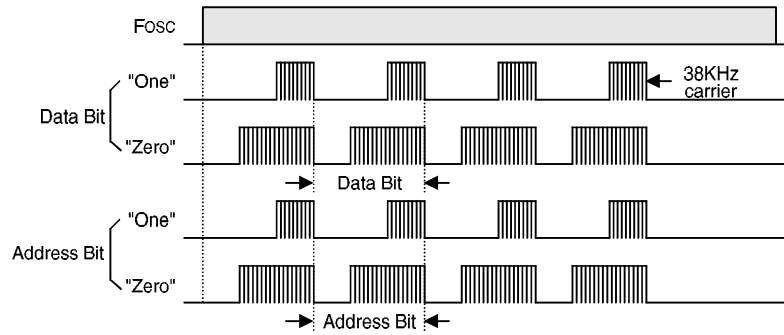

Fig.6 Address/Data bit waveform for the HT12A/C

The HT12B data code polarity is inverted:

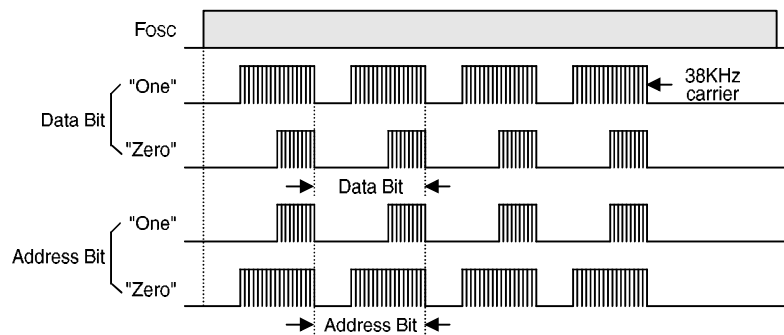

Fig.7 Address/Data bit waveform for the HT12B

The address/data bits of the HT12A/B/C are transmitted with a 38KHz carrier for Infra-Red remote controller flexibility.

**Address/data programming (preset)**

The status of each address/data pin can be individually pre-set to logic "high" or "low". If a transmission enable signal is applied, the encoder scans and transmits the status of the 12 bits of address/data serially in the order A0 to AD11 for the HT12E/EA encoder and A0 to D11 for the HT12A/B/C encoder.

During information transmission these bits are transmitted with a preceding synchronization bit. But if the trigger signal is not applied, the chip enters the stand-by mode and consumes a reduced current which is less than 1µA for a supply voltage of 5V.

Usual applications preset the address pins with individual security codes by the DIP switches or PCB wiring, while the data is selected by the push button or electronic switches.

The following figure shows an application using the HT12E/EA:

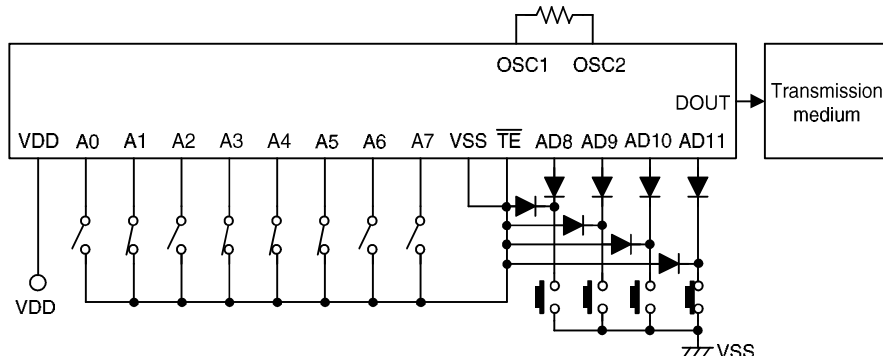

The transmitted information is as shown:

Pilot & Sync.	A0	A1	A2	A3	A4	A5	A6	A7	AD8	AD9	AD10	AD11
1	0	1	0	0	0	1	1	1	1	1	0	

**Address/Data sequence**

The following provides a table of the address/data sequence for various models of the 2<sup>12</sup> series encoders. A correct device should be selected according to the requirements of individual address and data.

HOLTEK Part No.	Address/Data Bits											
	0	1	2	3	4	5	6	7	8	9	10	11
HT12A	A0	A1	A2	A3	A4	A5	A6	A7	D8	D9	D10	D11
HT12B	A0	A1	A2	A3	A4	A5	A6	A7	D8	D9	D10	D11
HT12C	A0	A1	D2	D3	D4	D5	D6	D7	D8	D9	D10	D11
HT12E/EA	A0	A1	A2	A3	A4	A5	A6	A7	AD8	AD9	AD10	AD11



**Transmission enable**

For the HT12E/EA encoder, transmission is enabled by applying a low signal to the  $\overline{TE}$  pin. But for the HT12A/B/C encoders transmission it is enabled by applying a low signal to one of the data pins D2~D11.

**Two mistakable application circuits of HT12EA**

HT12EA equip a protection diode in input pins, that is the difference of HT12EA from HT12E (see the "Approximate internal connection circuits" on page4). The HT12EA must exact practice the application circuit by HOTEK's supply (see the "Application circuit" on page 14 or page8). Two mistakable examples as below.

www.DataSheet4U.com

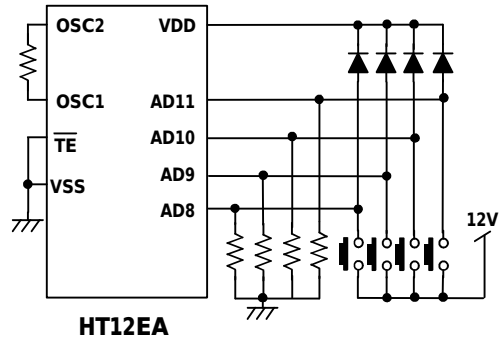

- mistakable cause: AD8~AD11 pins input voltage > VDD+0.3V

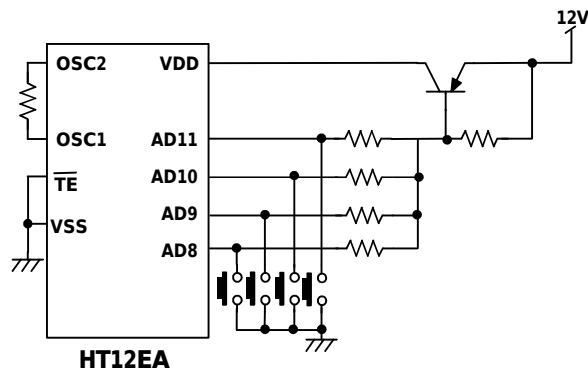

- mistakable cause: The IC's power source from AD8~AD11 pins

**Flowchart**  
HT12A/B/C

HT12E/EA

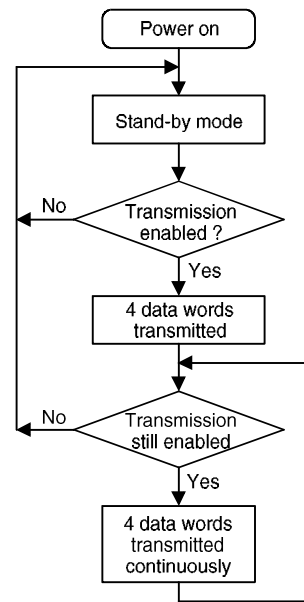
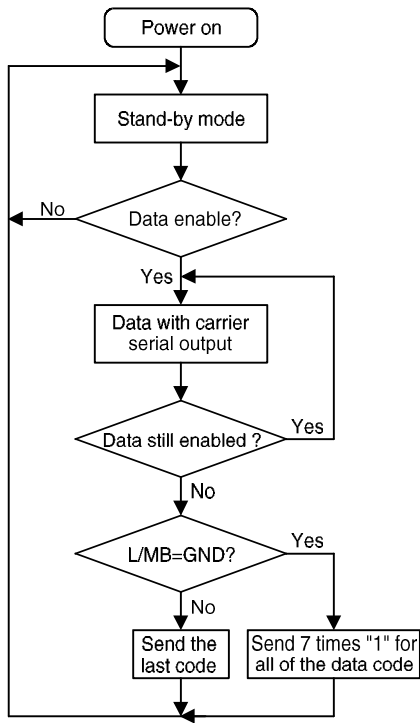

Note: D2~D11 are transmission enables of the HT12A/B/C.

$\overline{\text{TE}}$  is the transmission enable of the HT12E/EA.

Oscillator frequency chart of the HT12E/EA

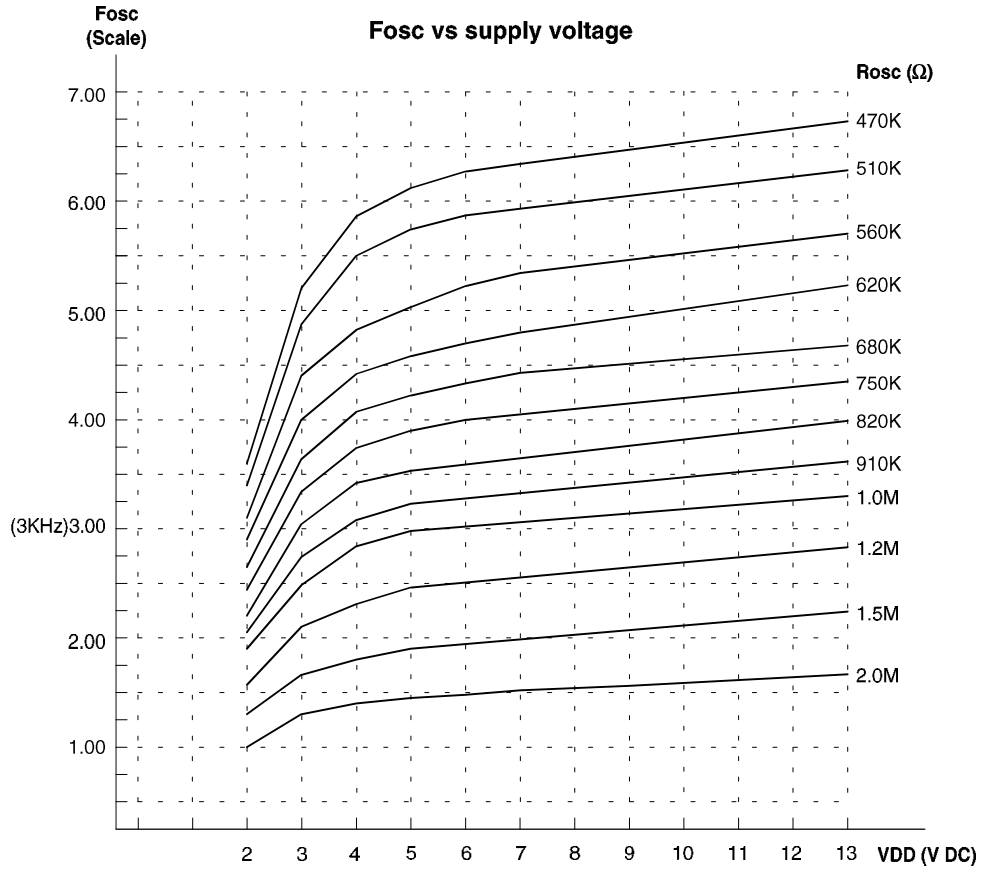

The recommended oscillator frequency is  $F_{OSCD}(\text{decoder}) \cong 50 F_{OSCE}(\text{HT12E/EA})$

$$\cong \frac{1}{3} F_{OSCE}(\text{HT12A/B/C}).$$

**Package Information**

**8 Address  
4 Data**

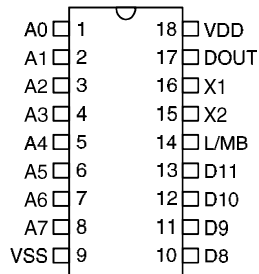

**HT12A  
-18 DIP**

**8 Address  
4 Data**

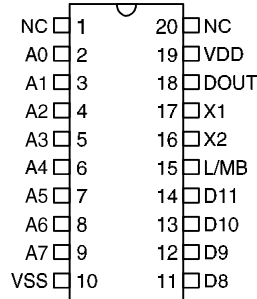

**HT12A  
-20 SOP**

**8 Address  
4 Data**

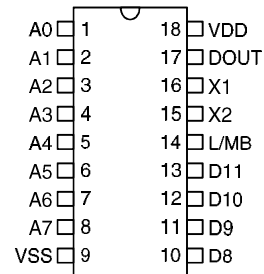

**HT12B  
-18 DIP**

**8 Address  
4 Data**

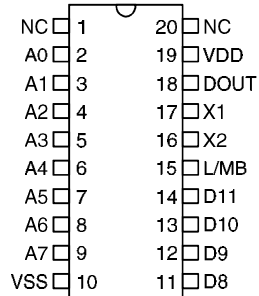

**HT12B  
-20 SOP**

**0 Address  
10 Data**

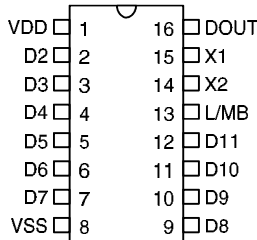

**HT12C  
-16 DIP/SOP**

**2 Address  
10 Data**

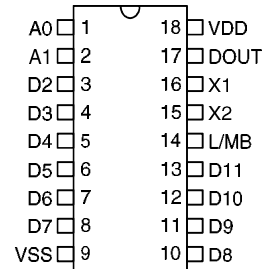

**HT12C  
-18 DIP**

www.DataSheet4U.com

**8 Address**

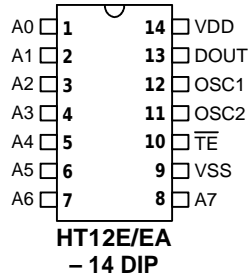

**8 Address  
2 Address/Data**

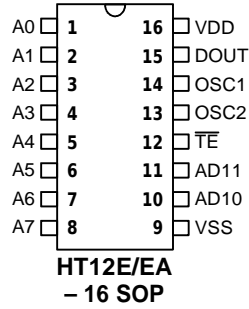

**8 Address  
4 Address/Data**

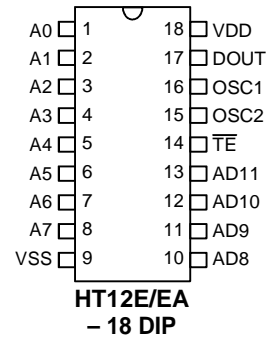

www.DataSheet4U.com

**8 Address  
4 Address/Data**

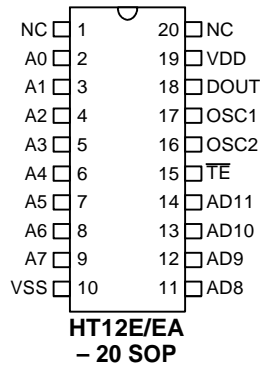

Application Circuits

Application circuit 1

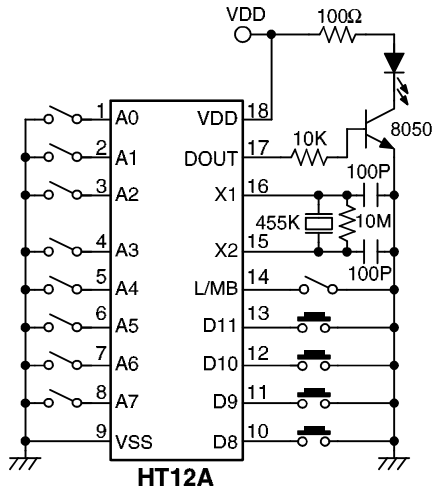

Application circuit 2

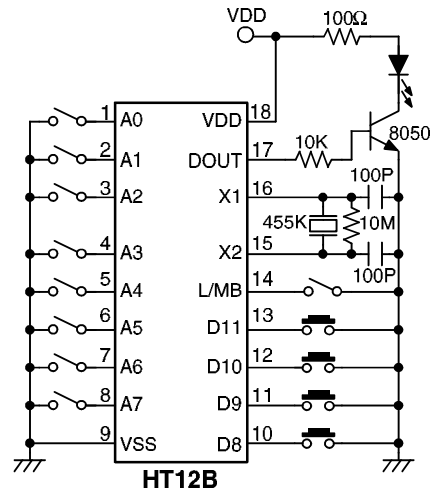

Application circuit 3

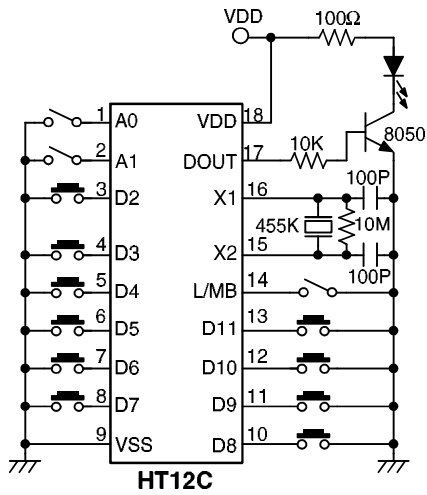

Application circuit 4

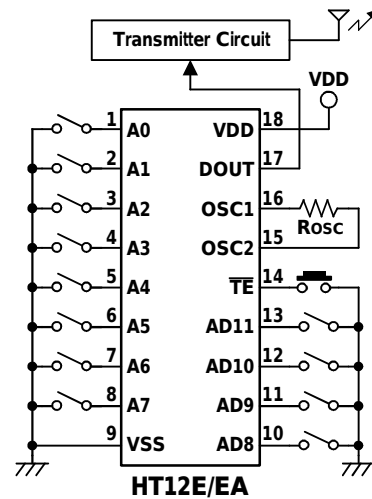

Note: Typical infrared diode: EL-1L2 (KODENSHI CORP.)

Typical RF transmitter: JR-220 (JUWA CORP.)

FD-493TX (FISCHER-OLSEN, GERMANY).