

E cores and accessories

E 25/13/7
(EF25)

General data for 10-pins E 25/13/7 coil former

PARAMETER	SPECIFICATION
Coil former material	polybutyleneterephthalate (PBT), glass reinforced, flame retardant in accordance with "UL 94V-0"; UL file number E45329
Pin material	copper-clad steel, tin- (Sn) plated
Maximum operating temperature	155 °C, "IEC 60085", class F
Resistance to soldering heat	"IEC 60068-2-20", Part 2, Test Tb, method 1B, 350 °C, 3.5 s
Solderability	"IEC 60068-2-20", Part 2, Test Ta, method 1, 235 °C, 2 s

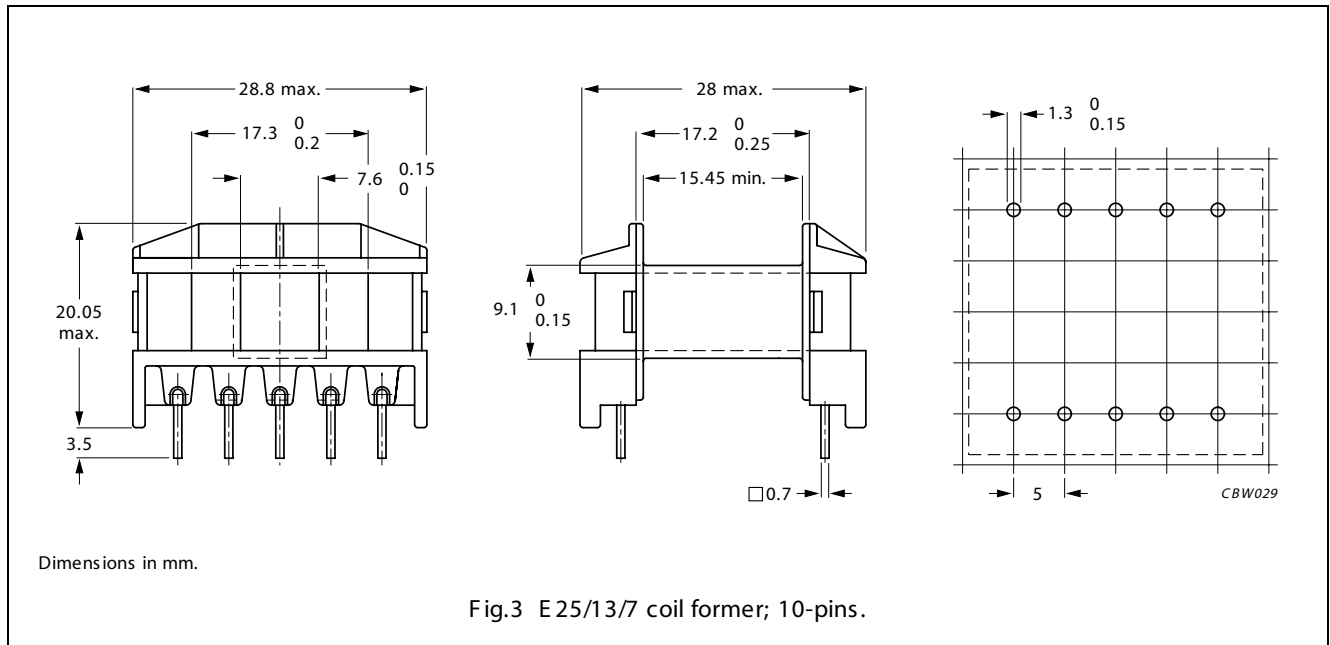

Winding data for 10-pins E 25/13/7 coil former

NUMBER OF SECTIONS	WINDING AREA (mm ²)	MINIMUM WINDING WIDTH (mm)	AVERAGE LENGTH OF TURN (mm)	TYPE NUMBER
1	63.3	15.45	52.8	CPH-E25/13/7-1S-10P