

MC3000 Series (0 to +75°C)/MC74H00

MC3100 Series (-55 to +125°C)/MC54H00

ISSUE A

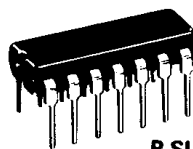

P SUFFIX
PLASTIC PACKAGE
CASE 646

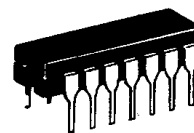

L SUFFIX
CERAMIC PACKAGE
CASE 632

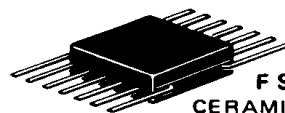

F SUFFIX
CERAMIC PACKAGE
CASE 607

MTTL III integrated circuits comprise a family of transistor-transistor logic designed for general purpose digital applications. The family has a high operating speed (30-50 MHz clock rate), good external noise immunity, high fan-out, and the capability of driving lines up to 600 pF capacitance.

FUNCTIONS AND CHARACTERISTICS ($V_{CC} = 5.0 \text{ V}$, $T_A = 25^\circ\text{C}$)

Function	Type ①		Loading Factor Each Output	Propagation Delay ns typ	Power Dissipation mW typ/pkg
	Case 605, 607, 632 0 to +70°C	Case 607, 632 -55°C to +125°C			
Quad 2-Input NAND Gate	MC3000(74H00)	MC3100(54H00)	10	6.0	88
Quad 2-Input AND Gate	MC3001	MC3101	10	9.0	112
Quad 2-Input NOR Gate	MC3002	MC3102	10	6.0	122
Quad 2-Input OR Gate	MC3003	MC3103	10	9.0	150
Quad 2-Input NAND Gate (Open Collector)	MC3004(74H01)	MC3104(54H01)	10	8.0	88
Triple 3-Input NAND Gate	MC3005(74H10)	MC3105(54H10)	10	6.0	66
Triple 3-Input AND Gate	MC3006(74H11)	MC3106(54H11)	10	9.0	84
Triple 3-Input NAND Gate (Open Collector)	MC3007	MC3107	10	8.0	66
Hex Inverter	MC3008(74H04)	MC3108(54H04)	10	6.0	140
Hex Inverter	MC3009(74H05)	MC3109(54H05)	10	8.0	90
Dual 4-Input NAND Gate	MC3010(74H20)	MC3110(54H20)	10	6.0	44
Dual 4-Input AND Gate	MC3011(74H21)	MC3111(54H21)	10	9.0	56
Dual 4-Input NAND Gate (Open Collector)	MC3012(74H22)	MC3112(54H22)	10	8.0	44
8-Input NAND Gate	MC3015	MC3115	10	8.0	22
8-Input NAND Gate	MC3016(74H30)	MC3116(54H30)	10	8.0	22
Expandable Dual 2-Wide 2-Input AND-OR-INVERT Gate	MC3020(74H50)	MC3120(54H50)	10	6.0	62.5
Quad 2-Input Exclusive OR Gate	MC3021	MC3121	8	14	100
Quad 2-Input Exclusive NOR Gate	MC3022	MC3122	8	14	85
Dual 2-Wide 2-Input AND-OR-INVERT Gate	MC3023(74H51)	MC3123(54H51)	10	6.0	62.5
Dual 4-Input NAND Buffer Gate	MC3024(74H40)	MC3124(54H40)	30	6.0	90
Dual 4-Input NAND Power Gate	MC3025	MC3125	20	6.0	70
Dual 4-Input AND Power Gate	MC3026	MC3126	20	9.0	90
Dual 3-Input 3-Output AND Series Terminated Line Driver	MC3028	MC3128	*	9.0	56
Dual 3-Input 3-Output NAND Series Terminated Line Driver	MC3029	MC3129	*	6.0	44
Expandable 4-Wide 2-2-2-3 Input AND-OR Gate	MC3031(74H52)	MC3131(54H52)	10	10	87.5
Expandable 4-Wide 2-2-2-3 Input AND-OR-INVERT Gate	MC3032(74H53)	MC3132(54H53)	10	7.0	40
AND Input J-K Flip-Flop	MC3051	MC3151	10	f = 50 MHz	50
AND Input JJ-KK Flip-Flop	MC3052	MC3152	10	f = 40 MHz	75
Dual Type D Flip-Flop	MC3060	MC3160	10	f = 30 MHz	120
Dual J-K Flip-Flop	MC3061	MC3161	10	f = 50 MHz	100
Dual J-K Flip-Flop	MC3062	MC3162	10	f = 50 MHz	100

① F suffix denotes Flat Package, L suffix denotes Dual In-Line Ceramic Package, P suffix denotes Plastic Package, (i.e., MC3000F = Flat Package, MC3000L = Ceramic Package, MC3000P = Plastic Package).

*Direct Output = 10 minus the number of resistor-terminated outputs being used.

GATES

<p>MC3000/MC3100 Quad 2-Input NAND Gate MC74H00/54H00</p> <p>$3 = 1 \cdot 2$</p> <p>$t_{pd} = 6.0 \text{ ns typ}$ $P_D = 88 \text{ mW typ/pkg}$</p>	<p>MC3001/MC3101 Quad 2-Input AND Gate</p> <p>$3 = 1 \cdot 2$</p> <p>$t_{pd} = 9.0 \text{ ns typ}$ $P_D = 112 \text{ mW typ/pkg}$</p>	<p>MC3002/MC3102 Quad 2-Input NOR Gate</p> <p>$3 = 1 + 2$</p> <p>$t_{pd} = 6.0 \text{ ns typ}$ $P_D = 122 \text{ mW typ/pkg}$</p>
<p>MC3003/MC3103 (74H32)/(54H32) Quad 2-Input OR Gate</p> <p>$3 = 1 + 2$</p> <p>$t_{pd} = 9.0 \text{ ns typ}$ $P_D = 150 \text{ mW typ/pkg}$</p>	<p>MC3004/MC3104 (74H01)/(54H01) Quad 2-Input NAND Gate (Open Collector)</p> <p>$3 = 1 \cdot 2$</p> <p>$t_{pd} = 8.0 \text{ ns typ}$ $P_D = 88 \text{ mW typ/pkg}$</p>	<p>MC3005/MC3105 Triple 3-Input NAND Gate MC74H10/54H10</p> <p>$12 = 1 \cdot 2 \cdot 13$</p> <p>$t_{pd} = 6.0 \text{ ns typ}$ $P_D = 66 \text{ mW typ/pkg}$</p>
<p>MC3006/MC3106 Triple 3-Input AND Gate MC74H11/MC54H11</p> <p>$12 = 1 \cdot 2 \cdot 13$</p> <p>$t_{pd} = 9.0 \text{ ns typ}$ $P_D = 84 \text{ mW typ/pkg}$</p>	<p>MC3007/MC3107 Triple 3-Input NAND Gate (Open Collector)</p> <p>$12 = 1 \cdot 2 \cdot 13$</p> <p>$t_{pd} = 8.0 \text{ ns typ}$ $P_D = 66 \text{ mW typ/pkg}$</p>	<p>MC3010/MC3110 Dual 4-Input NAND Gate MC74H20/MC54H20</p> <p>$6 = 1 \cdot 2 \cdot 4 \cdot 5$</p> <p>$t_{pd} = 6.0 \text{ ns typ}$ $P_D = 44 \text{ mW typ/pkg}$</p>

(continued)

Numbers at ends of terminals represent pin numbers.
Numbers in parenthesis indicate loading.

V_{CC} = Pin 14, Gnd = Pin 7.

GATES (continued)

MC3011/MC3111
Dual 4-Input AND Gate
MC74H21/MC54H21

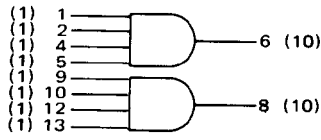

$$6 = 1 \cdot 2 \cdot 4 \cdot 5$$

t_{pd} = 9.0 ns typ
P_D = 56 mW typ/pkg

MC3012/MC3112
Quad 4-Input NAND Gate
(Open Collector)
MC74H22/MC54H22

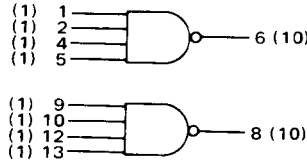

$$6 = \overline{1 \cdot 2 \cdot 4 \cdot 5}$$

t_{pd} = 8.0 ns typ
P_D = 44 mW typ/pkg

MC3015/MC3115
8-Input NAND Gate

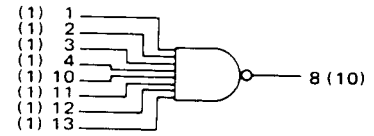

$$8 = \overline{1 \cdot 2 \cdot 3 \cdot 4 \cdot 10 \cdot 11 \cdot 12 \cdot 13}$$

t_{pd} = 8.0 ns typ
P_D = 22 mW typ/pkg

MC3016/MC3116
8-Input NAND Gate
MC74H30/MC54H30

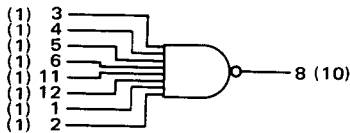

$$8 = \overline{3 \cdot 4 \cdot 5 \cdot 6 \cdot 11 \cdot 12 \cdot 1 \cdot 2}$$

t_{pd} = 8.0 ns typ
P_D = 22 mW typ/pkg

MC3020/MC3120
Expandable Dual 2-Wide 2-Input
AND-OR-INVERT Gate
MC74H50/MC54H50

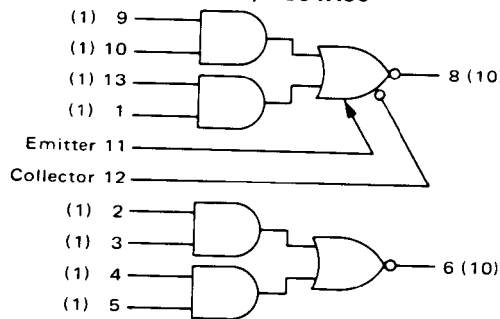

$$8 = (9 \cdot 10) + (13 \cdot 1) + (\text{Expanders})$$

t_{pd} = 6.0 ns typ
P_D = 62.5 mW typ/pkg

MC3021/MC3121
Quad 2-Input
Exclusive OR Gate

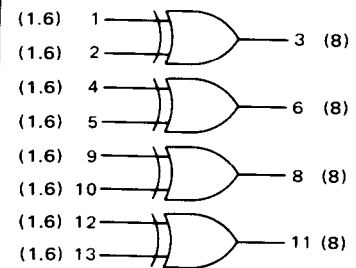

$$3 = 1 \cdot \bar{2} + \bar{1} \cdot 2$$

t_{pd} = 14 ns typ
P_D = 100 mW typ/pkg

MC3022/MC3122
Quad 2-Input
Exclusive NOR Gate

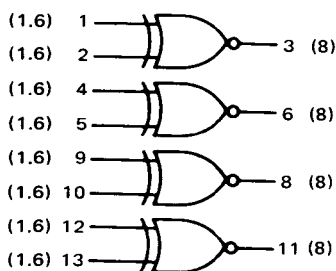

$$3 = \bar{1} \cdot \bar{2} + 1 \cdot 2$$

t_{pd} = 14 ns typ
P_D = 85 mW typ/pkg

MC3023/MC3123
Dual 2-Wide 2-Input
AND-OR-INVERT Gate
MC74H51/MC54H51

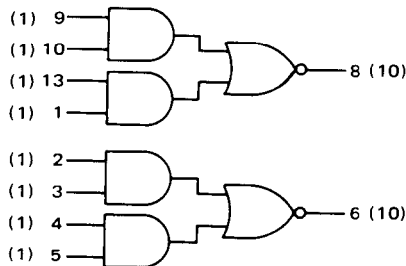

$$8 = \overline{(9 \cdot 10) + (13 \cdot 1)}$$

t_{pd} = 6.0 ns typ
P_D = 62.5 mW typ/pkg

MC3024/MC3124
Dual 4-Input NAND
Buffer Gate
MC74H40/MC54H40

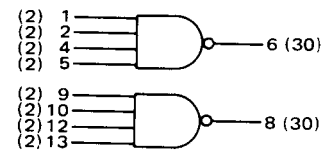

$$6 = \overline{1 \cdot 2 \cdot 4 \cdot 5}$$

typ = 6.0 ns typ
P_D = 90 mW typ/pkg

(continued)

MTTL III LOGIC DIAGRAMS

GATES (continued)

MC3031/MC3131
Expandable 4-Wide 2-2-2-3-Input
AND-OR Gate
MC74H52/MC54H52

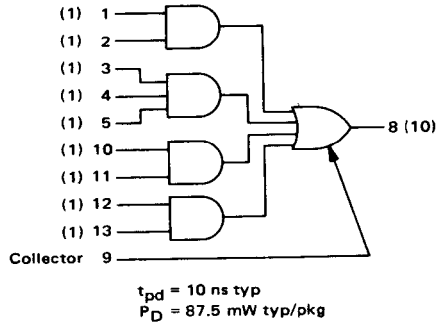

MC3032/MC3132
Expandable 4-Wide 2-2-2-3-Input
AND-OR-INVERT Gate
MC74H53/MC54H53

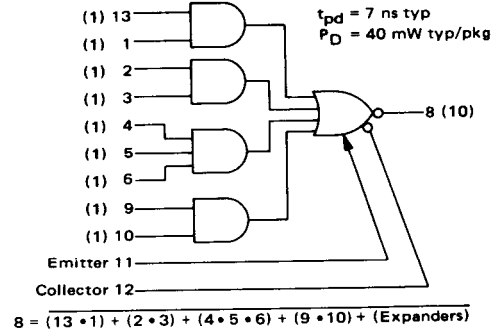

POWER GATES

MC3025/MC3125
Dual 4-Input NAND Power Gate

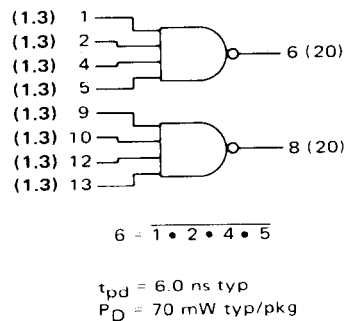

MC3026/MC3126
Dual 4-Input AND Power Gate

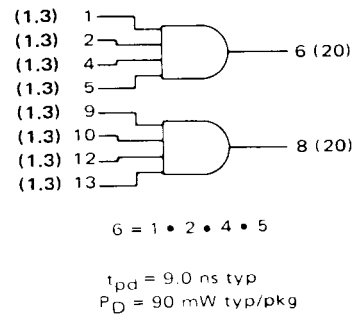

LINE DRIVERS

MC3028/MC3128
Dual 3-Input 3-Output AND
Series Terminated Line Driver

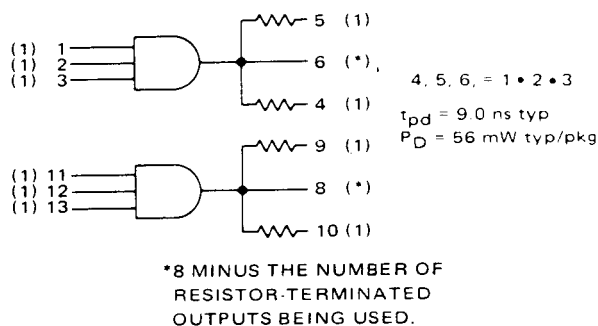

MC3029/MC3129
Dual 3-Input 3-Output NAND
Series Terminated Line Driver

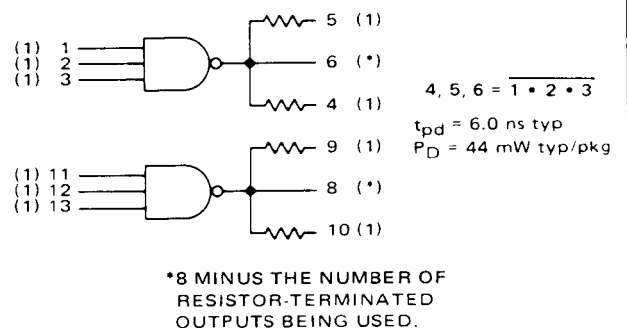

INVERTERS

MC3008/MC3108 Hex Inverter MC74H04/Mc54H04

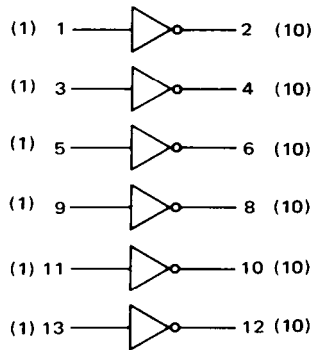

$$2 = \bar{1}$$

$t_{pd} = 6.0 \text{ ns typ}$
 $P_D = 140 \text{ mW typ/pkg}$

MC3009/MC3109 Hex Inverter Open Collector MC74H05/MC54H05

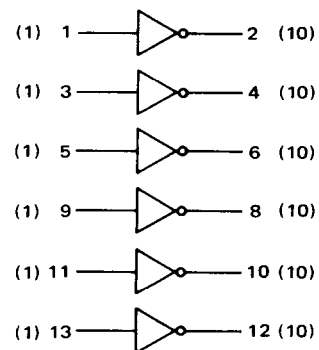

$$2 = \bar{1}$$

$t_{pd} = 8.0 \text{ ns typ}$
 $P_D = 90 \text{ mW typ/pkg}$

FLIP-FLOPS

MC3051/MC3151 AND J-K Flip-Flop

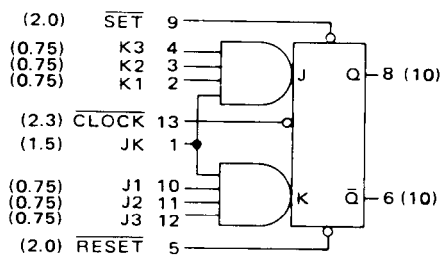

where

$$J = J1 \cdot J2 \cdot J3 \cdot JK$$

$$K = K1 \cdot K2 \cdot K3 \cdot JK$$

$f = 50 \text{ MHz}$
 $P_D = 50 \text{ mW typ/pkg}$

J	K	Q^n	Q^{n+1}
0	0	0	0
0	0	1	1
0	1	0	0
0	1	1	0
1	0	0	1
1	0	1	1
1	1	0	1
1	1	1	0

MC3052/MC3152 AND Input JJ-KK Flip-Flop

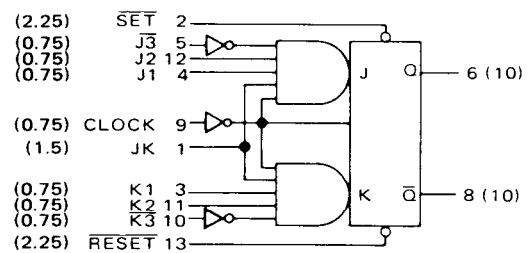

Where:

$$J = J1 \cdot J2 \cdot J3 \cdot JK$$

$$K = K1 \cdot K2 \cdot K3 \cdot JK$$

$f = 40 \text{ MHz}$
 $P_D = 75 \text{ mW typ/pkg}$

J	K	Q^n	Q^{n+1}
0	0	0	0
0	0	1	1
0	1	0	0
0	1	1	0
1	0	0	1
1	0	1	1
1	1	0	1
1	1	1	0

FLIP-FLOPS (continued)

MC3060/MC3160 Dual Type D Flip-Flop

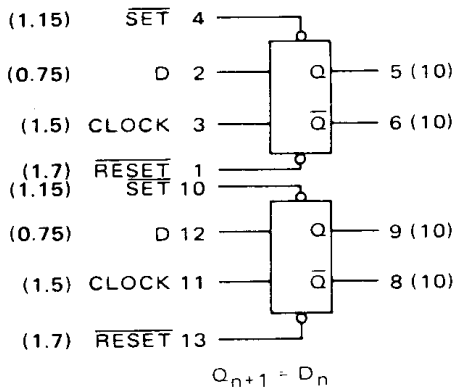

D	Q_n	Q_{n+1}
0	0	0
0	1	0
1	0	1
1	1	1

$f = 30 \text{ MHz}$
 $P_D = 120 \text{ mW typ/pkg}$

MC3061/MC3161 Dual J-K Flip-Flop

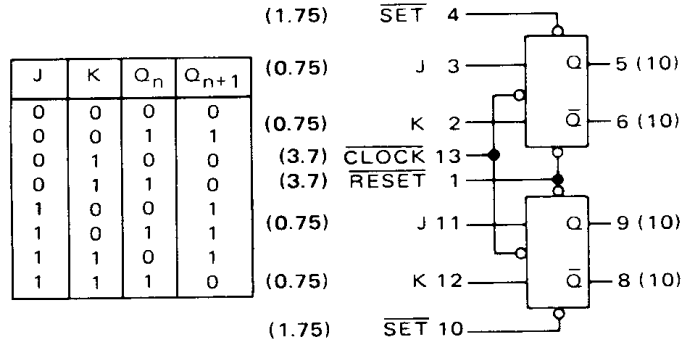

J	K	Q_n	Q_{n+1}
0	0	0	0
0	0	1	1
0	1	0	0
0	1	1	0
1	0	0	1
1	0	1	1
1	1	0	1
1	1	1	0

$f = 50 \text{ MHz}$
 $P_D = 100 \text{ mW typ/pkg}$

MC3062/MC3162 Dual J-K Flip-Flop

J	K	Q_n	Q_{n+1}
0	0	0	0
0	0	1	1
0	1	0	0
0	1	1	0
1	0	0	1
1	0	1	1
1	1	0	1
1	1	1	0

$f = 50 \text{ MHz}$
 $P_D = 100 \text{ mW typ/pkg}$

