

Low Profile Miniature Glass Passivated Single-Phase Surface Mount Bridge Rectifier

MB05F thru MB10F

VOLTAGE - 50 TO 1000 VOLTS CURRENT - 0.5 AMPERES



MBF

FEATURES

- Low profile space
- Ideal for automated placement
- Glass passivated chip junction
- Low forward voltage drop
- Low leakage current
- High forward surge capability
- High temperature soldering:
260°C/10 seconds at terminals
- Component in accordance to
RoHS 2002/95/1 and WEEE 2002/96/EC

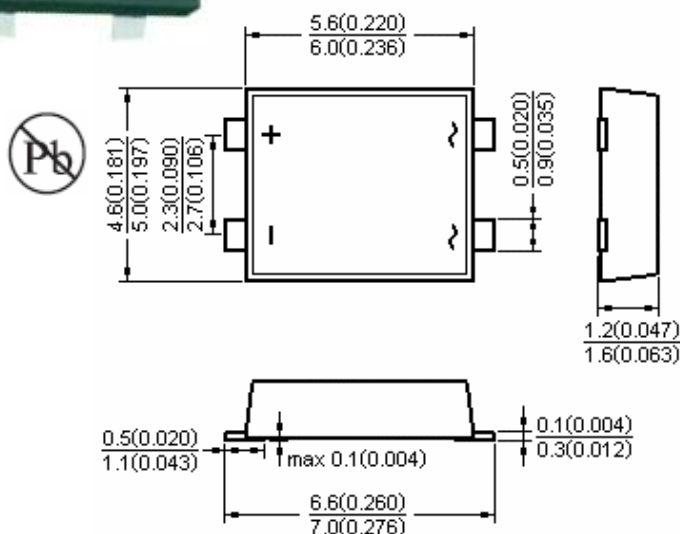

Dimensions in millimeters and (inches)

MECHANICAL DATA

- Case: MBF Molded plastic over glass passivated chip
- Terminals: Solder plated, solderable per J-STD-002B and JESD22-B102D
- Polarity: Polarity symbols marked on body

MAXIMUM RATINGS AND ELECTRICAL CHARACTERISTICS

(T_A = 25 °C unless otherwise noted)

	Symbol	MB05F	MB1F	MB2F	MB4F	MB6F	MB8F	MB10F	UNIT	
Maximum repetitive peak reverse voltage	V _{RRM}	50	100	200	400	600	800	1000	V	
Maximum RMS voltage	V _{RMS}	35	70	140	280	420	560	700	V	
Maximum DC blocking voltage	V _{DC}	50	100	200	400	600	800	1000	V	
Maximum average forward output rectified current at T _A =30°C -on glass-epoxy P.C.B(NOTE 1) -on aluminum substrate(NOTE 2)	I _{F(AV)}								0.5 0.8	A
Peak forward surge current 8.3 ms single half sine-wave superimposed on rated load(JEDEC Method)	I _{FSM}								35	A
Maximum instantaneous forward voltage drop per leg at 0.4A	V _F								1	V
Maximum DC reverse current at T _A = 25 °C rated DC blocking voltage per leg T _A = 125 °C	I _R								5.0 100	μ A
Typical junction capacitance per leg at 4.0 V ,1MHz	C _J								13	p F
Thermal resistance per leg	(NOTE 1) R _{θJA}								85	°C/ W
	(NOTE 2) R _{θJA}								70	
	(NOTE 1) R _{θJL}								20	
Operating junction and storage temperature range	T _J , T _{STG}								-55 to +150	°C

NOTE1: On glass epoxy P.C.B. mounted on 0.05×0.05" (1.3×1.3mm) pads

NOTE2: On aluminum substrate P.C.B. with an area of 0.8" × 0.8" (20×20mm) mounted on 0.05×0.05" (1.3×1.3mm) solder pad

MB05F thru MB10F

VOLTAGE - 50 TO 1000 VOLTS CURRENT - 0.5 AMPERES

Characteristic Curves ($T_A=25^\circ\text{C}$ unless otherwise noted)

Fig.1 Derating Curve For Output Rectified Current

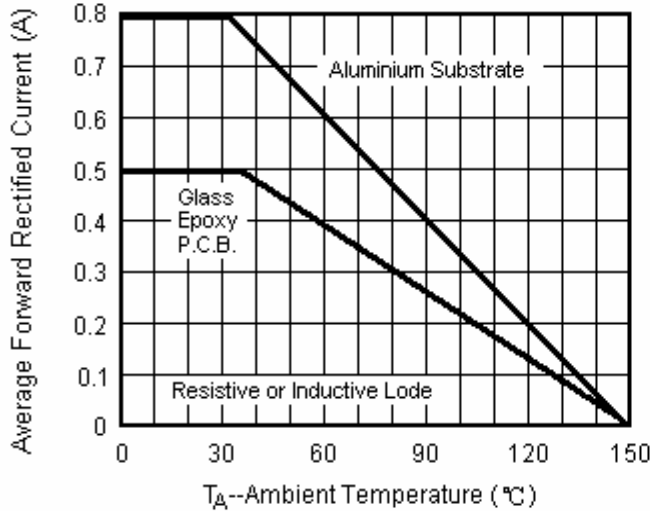

Fig.2 Maximum Non-Repetitive Peak Forward Surge Current Per Leg

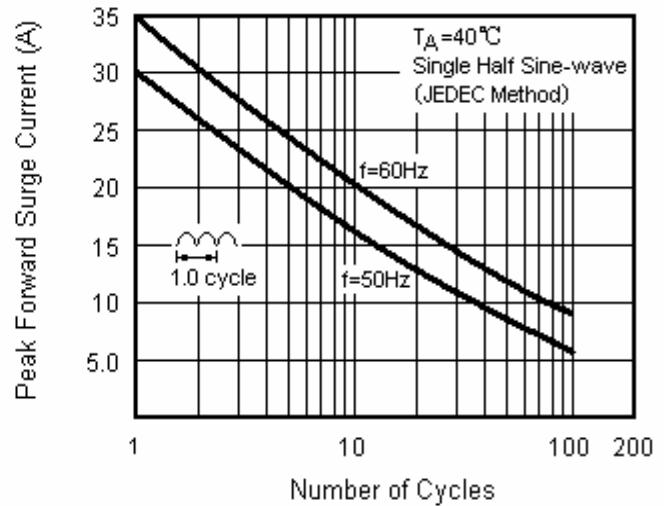

Fig.3 Typical Forward Voltage Characteristics Per Leg

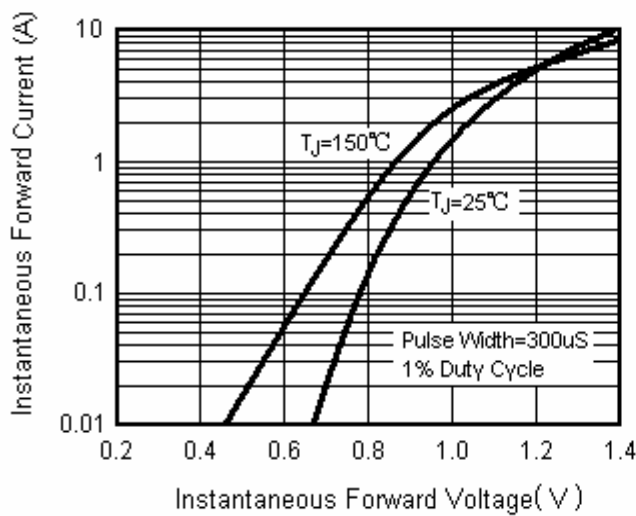

Fig.4 Typical Reverse Leakage Characteristics Per Leg

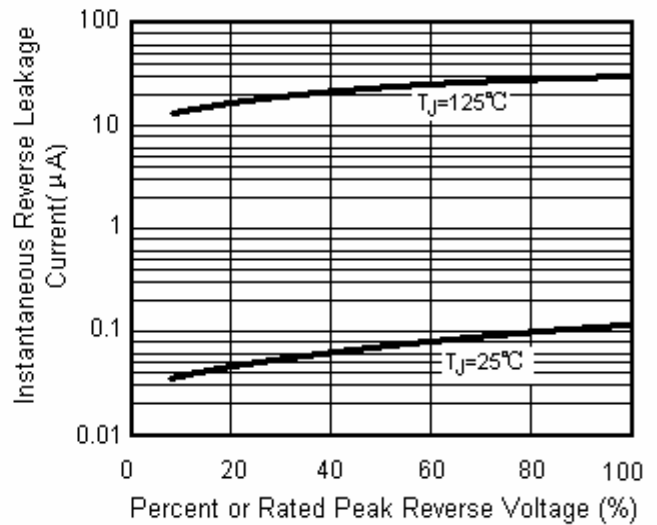

Fig.5 Typical Junction Capacitance Per Leg

