

IT8722F

**Media Interface – Low Pin Count Input / Output
(Media - I/O)**

Preliminary Specification V0.31

INTEGRATED TECHNOLOGY EXPRESS, INC.

Copyright © 2002 ITE, Inc.

This is Preliminary document release. All specifications are subject to change without notice. The material contained in this document supersedes all previous documentation issued for the related products included herein. Please contact ITE, Inc. for the latest document(s).

All sales are subject to ITE's Standard Terms and Conditions, a copy of which is included in the back of this document.

ITE, IT8722F is a trademark of ITE, Inc.
Intel is claimed as a trademark by Intel Corp.
Microsoft and Windows are claimed as trademarks by Microsoft Corporation.
PCI is claimed as a trademark by the PCI Special Interest Group.
IrDA is claimed as a trademark by the Infrared Data Association.
All other trademarks are claimed by their respective owners.
All specifications are subject to change without notice.

Additional copies of this manual or other ITE literature may be obtained from :

ITE, Inc.
Marketing Department
8F, No. 233-1, Bao Chiao RD., Hsin Tien,
Taipei County 231, Taiwan, R.O.C.

Phone: (02) 29126889
Fax: (02) 2910-2551, 2910-2552

ITE (USA) Inc.
Marketing Department
1235 Midas Way
Sunnyvale, CA 94086
U.S.A.

Phone: (408) 530-8860
Fax: (408) 530-8861

ITE (USA) Inc.
Eastern U.S.A. Sales Office
896 Summit St., #105
Round Rock, TX 78664
U.S.A.

Phone: (512) 388-7880
Fax: (512) 388-3108

If you have any marketing or sales questions, please contact:

Lawrence Liu, at ITE Taiwan: E-mail: lawrence.liu@ite.com.tw, Tel: 886-2-29126889 X6071,
Fax: 886-2-29102551

David Lin, at ITE U.S.A: E-mail: david.lin@iteusa.com, Tel: (408) 530-8860 X238,
Fax: (408) 530-8861

Don Gardenhire, at ITE Eastern USA Office: E-mail: don.gardenhire@iteusa.com,
Tel: (512) 388-7880, Fax: (512) 388-3108

To find out more about ITE, visit our World Wide Web at:

<http://www.iteusa.com>
<http://www.ite.com.tw>

Or e-mail itesupport@ite.com.tw for more product information/services.

CONTENTS

1. Features	1
2. General Description	3
3. Block Diagram	5
4. Pin Configuration	7
5. IT8722F Pin Descriptions	9
6. List of GPIO Pins	25
7. Power On Strapping Options and Special Pin Routings	27
8. Configuration	29
8.1 Configuring Sequence Description	29
8.2 Description of the Configuration Registers	30
8.2.1 Logical Device Base Address	36
8.3 Global Configuration Registers (LDN: All)	37
8.3.1 Configure Control (Index=02h)	37
8.3.2 Logical Device Number (LDN, Index=07h)	37
8.3.3 Chip ID Byte 1 (Index=20h, Default=87h)	37
8.3.4 Chip ID Byte 2 (Index=21h, Default=22h)	37
8.3.5 Chip Version (Index=22h, Default=00h)	37
8.3.6 Clock Selection Register (Index=23h, Default=00h)	37
8.3.7 Software Suspend (Index=24h, Default=00h, MB PnP)	37
8.3.8 GPIO Set 1 Multi-Function Pin Selection Register (Index=25h, Default=00h)	38
8.3.9 GPIO Set 2 Multi-Function Pin Selection Register (Index=26h, Default=00h)	39
8.3.10 GPIO Set 3 Multi-Function Pin Selection Register (Index=27h, Default=00h)	40
8.3.11 GPIO Set 4 Multi-Function Pin Selection Register (Index=28h, Default=00h)	41
8.4 GPIO Set 5 Multi-Function Pin Selection Register (Index=29h, Default=00h)	42
8.4.1 Test 1 Register (Index=2Eh, Default=00h)	42
8.4.2 Test 2 Register (Index=2Fh, Default=00h)	42
8.5 FDC Configuration Registers (LDN=00h)	42
8.5.1 FDC Activate (Index=30h, Default=00h)	42
8.5.2 FDC Base Address MSB Register (Index=60h, Default=03h)	43
8.5.3 FDC Base Address LSB Register (Index=61h, Default=F0h)	43
8.5.4 FDC Interrupt Level Select (Index=70h, Default=06h)	43
8.5.5 FDC DMA Channel Select (Index=74h, Default=02h)	43
8.5.6 FDC Special Configuration Register 1 (Index=F0h, Default=00h)	43
8.5.7 FDC Special Configuration Register 2 (Index=F1h, Default=00h)	43
8.6 Serial Port 1 Configuration Registers (LDN=01h)	44
8.6.1 Serial Port 1 Activate (Index=30h, Default=00h)	44
8.6.2 Serial Port 1 Base Address MSB Register (Index=60h, Default=03h)	44
8.6.3 Serial Port 1 Base Address LSB Register (Index=61h, Default=F8h)	44
8.6.4 Serial Port 1 Interrupt Level Select (Index=70h, Default=04h)	44
8.6.5 Serial Port 1 Special Configuration Register 1 (Index=F0h, Default=00h)	44
8.6.6 Serial Port 1 Special Configuration Register 2 (Index=F1h, Default=50h)	45
8.6.7 Serial Port 1 Special Configuration Register 3 (Index=F2h, Default=00h)	45
8.6.8 Serial Port 1 Special Configuration Register 4 (Index=F3h, Default=7Fh)	45
8.7 Serial Port 2 Configuration Registers (LDN=02h)	45
8.7.1 Serial Port 2 Activate (Index=30h, Default=00h)	45

8.7.2	Serial Port 2 Base Address MSB Register (Index=60h, Default=02h).....	45
8.7.3	Serial Port 2 Base Address LSB Register (Index=61h, Default=F8h).....	46
8.7.4	Serial Port 2 Interrupt Level Select (Index=70h, Default=03h)	46
8.7.5	Serial Port 2 Special Configuration Register 1 (Index=F0h, Default=00h).....	46
8.7.6	Serial Port 2 Special Configuration Register 2 (Index=F1h, Default=50h).....	46
8.7.7	Serial Port 2 Special Configuration Register 3 (Index=F2h, Default=00h).....	47
8.7.8	Serial Port 2 Special Configuration Register 4 (Index=F3h, Default=7Fh)	47
8.8	Parallel Port Configuration Registers (LDN=03h).....	47
8.8.1	Parallel Port Activate (Index=30h, Default=00h).....	47
8.8.2	Parallel Port Primary Base Address MSB Register (Index=60h, Default=03h).....	47
8.8.3	Parallel Port Primary Base Address LSB Register (Index=61h, Default=78h).....	47
8.8.4	Parallel Port Secondary Base Address MSB Register (Index=62h, Default=07h).....	48
8.8.5	Parallel Port Secondary Base Address LSB Register (Index=63h, Default=78h).....	48
8.8.6	Parallel Port Interrupt Level Select (Index =70h, Default=07h).....	48
8.8.7	Parallel Port DMA Channel Select (Index=74h, Default=03h)	48
8.8.8	Parallel Port Special Configuration Register (Index=F0h, Default=03h).....	48
8.9	Environment Controller Configuration Registers (LDN=04h)	49
8.9.1	Environment Controller Activate Register (Index=30h, Default=00h)	49
8.9.2	Environment Controller Base Address MSB Register (Index=60h, Default=02h).....	49
8.9.3	Environment Controller Base Address LSB Register (Index=61h, Default=90h).....	49
8.9.4	PME Direct Access Base Address MSB Register (Index=62h, Default=02h).....	49
8.9.5	PME Direct Access Base Address LSB Register (Index=63h, Default=30h).....	49
8.9.6	Environment Controller Interrupt Level Select (Index=70h, Default=09h)	49
8.9.7	APC/PME Event Enable Register (PER) (Index=F0h, Default=00h)	50
8.9.8	APC/PME Status Register (PSR) (Index=F1h, Default=00h)	50
8.9.9	APC/PME Control Register 1 (PCR 1) (Index=F2h, Default=00h).....	51
8.9.10	Environment Controller Special Configuration Register (Index=F3h, Default=00h)	51
8.9.11	APC/PME Control Register 2 (PCR 2) (Index=F4h, Default=00h).....	51
8.9.12	APC/PME Special Code Index Register (Index=F5h).....	51
8.9.13	APC/PME Special Code Data Register (Index=F6h).....	52
8.10	KBC (keyboard) Configuration Registers (LDN=05h).....	52
8.10.1	KBC (keyboard) Activate (Index=30h, Default=01h or 00h).....	52
8.10.2	KBC (keyboard) Data Base Address MSB Register (Index=60h, Default=00h)	52
8.10.3	KBC (keyboard) Data Base Address LSB Register (Index=61h, Default=60h)	52
8.10.4	KBC (keyboard) Command Base Address MSB Register (Index=62h, Default=00h)	52
8.10.5	KBC (keyboard) Command Base Address LSB Register (Index=63h, Default=64h)	52
8.10.6	KBC (keyboard) Interrupt Level Select (Index=70h, Default=01h).....	52
8.10.7	KBC (keyboard) Interrupt Type (Index=71h, Default=02h)	52
8.10.8	KBC (keyboard) Special Configuration Register (Index=F0h, Default=00h).....	53
8.11	KBC (mouse) Configuration Registers (LDN=06h)	53
8.11.1	KBC (mouse) Activate (Index=30h, Default=00h).....	53
8.11.2	KBC (mouse) Interrupt Level Select (Index=70h, Default=0Ch).....	53
8.11.3	KBC (mouse) Interrupt Type (Index=71h, Default=02h)	54
8.11.4	KBC (mouse) Special Configuration Register (Index=F0h, Default=00h).....	54
8.12	GPIO Configuration Registers (LDN=07h)	54
8.12.1	SMI# Normal Run Access Base Address MSB Register (Index=60h, Default=00h)	54
8.12.2	SMI# Normal Run Access Base Address LSB Register (Index=61h, Default=00h)	54
8.12.3	Simple I/O Base Address MSB Register (Index=62h, Default=00h).....	54
8.12.4	Simple I/O Base Address LSB Register (Index=63h, Default=00h).....	54
8.12.5	Panel Button De-bounce Base Address MSB Register (Index=64h, Default=00h)	54
8.12.6	Panel Button De-bounce Base Address LSB Register (Index=65h, Default=00h)	55
8.12.7	Panel Button De-bounce Interrupt Level Select Register (Index=70h, Default=00h).....	55

8.12.8	Watch Dog Timer Control Register (Index=71h, Default=00h).....	55
8.12.9	Watch Dog Timer Configuration Register (Index=72h, Default=00h).....	55
8.12.10	Watch Dog Timer Time-Out Value Register (Index=73h, Default=00h).....	55
8.12.11	GPIO Pin Set 1, 2, 3, 4 and 5 Polarity Registers (Index=B0h, B1h, B2h, B3h and B4h, Default=00h).....	55
8.12.12	GPIO Pin Set 1, 2, 3, 4 and 5 Pin Internal Pull-up Enable Registers (Index=B8h, B9h, BAh, BBh and BCh, Default=00h).....	56
8.12.13	Simple I/O Set 1, 2, 3, 4 and 5 Enable Registers (Index=C0h, C1h, C2h, C3h and C4h, Default=00h).....	56
8.12.14	Simple I/O Set 1, 2, 3, 4 and 5 Output Enable Registers (Index=C8h, C9h, CAh, CBh and CCh, Default=00h).....	56
8.12.15	Panel Button De-bounce Control Register (Index=D0h, Default=00h).....	56
8.12.16	Panel Button De-bounce Set 1, 2, 3, 4 and 5 Enable Registers (Index=D1h, D2h, D3h, D4h and D5h, Default=00h).....	56
8.12.17	IRQ3-7, 9-12 and 14-15 External Routing Input Pin Mapping Registers (Index=E3h-E7h, E9h-ECh and EEh-EFh, Default=00h).....	57
8.12.18	SMI# Control Register 1 (Index=F0h, Default=00h).....	57
8.12.19	SMI# Control Register 2 (Index=F1h, Default=00h).....	57
8.12.20	SMI# Status Register 1 (Index=F2h, Default=00h).....	57
8.12.21	SMI# Status Register 2 (Index=F3h, Default=00h).....	58
8.12.22	SMI# Pin Mapping Register (Index=F4h, Default=00h).....	58
8.12.23	Hardware Monitor Thermal Output Pin Mapping Register (Index=F5h, Default=00h).....	58
8.12.24	Hardware Monitor Alert Beep Pin Mapping Register (Index=F6h, Default=00h).....	58
8.12.25	Keyboard Lock Pin Mapping Register (Index=F7h, Default=00h).....	58
8.12.26	GP LED Blinking 1 Pin Mapping Register (Index=F8h, Default=00h).....	58
8.12.27	GP LED Blinking 1 Control Register (Index=F9h, Default=00h).....	59
8.12.28	GP LED Blinking 2 Pin Mapping Register (Index=FAh, Default=00h).....	59
8.12.29	GP LED Blinking 2 Control Register (Index=FBh, Default=00h).....	59
8.13	MIDI Port Configuration Registers (LDN=08h).....	59
8.13.1	MIDI Port Activate (Index=30h, Default=00h).....	59
8.13.2	MIDI Port Base Address MSB Register (Index=60h, Default=03h).....	59
8.13.3	MIDI Port Base Address LSB Register (Index=61h, Default=00h).....	60
8.13.4	MIDI Port Interrupt Level Select (Index=70h, Default=0Ah).....	60
8.13.5	MIDI Port Special Configuration Register (Index=F0h, Default=00h).....	60
8.14	Game Port Configuration Registers (LDN=09h).....	60
8.14.1	Game Port Activate (Index=30h, Default=00h).....	60
8.14.2	Game Port Base Address MSB Register (Index=60h, Default=02h).....	60
8.14.3	Game Port Base Address LSB Register (Index=61h, Default=01h).....	60
8.15	Consumer IR Configuration Registers (LDN=0Ah).....	61
8.15.1	Consumer IR Activate (Index=30h, Default=00h).....	61
8.15.2	Consumer IR Base Address MSB Register (Index=60h, Default=03h).....	61
8.15.3	Consumer IR Base Address LSB Register (Index=61h, Default=10h).....	61
8.15.4	Consumer IR Interrupt Level Select (Index=70h, Default=0Bh).....	61
8.15.5	Consumer IR Special Configuration Register (Index=F0h, Default=00h).....	61
8.16	Memory Stick Configuration Registers (LDN=0Bh).....	61
8.16.1	Memory Stick Activate (Index=30h, Default=00h).....	61
8.16.2	Memory Stick Base Address MSB Register (Index=60h, Default=02h).....	62
8.16.3	Memory Stick Base Address LSB Register (Index=61h, Default=20h).....	62
8.16.4	Memory Stick Interrupt Level Select (Index=70h, Default=05h).....	62
8.16.5	Memory Stick DMA Channel Select (Index=74h, Default=05h).....	62
8.16.6	Memory Stick Special Configuration Register (Index=F0h, Default=00h).....	62
8.17	SD Configuration Registers (LDN=0Ch).....	62

8.17.1	SD Activate (Index=30h, Default=00h)	62
8.17.2	SDBase Address MSB Register (Index=60h, Default=02h)	63
8.17.3	SD Base Address LSB Register (Index=61h, Default=30h)	63
8.17.4	SD Interrupt Level Select (Index=70h, Default=09h)	63
8.17.5	SD DMA Channel Select (Index=74h, Default=06h)	63
8.17.6	SD Special Configuration Register (Index=F0h, Default=00h)	63
9.	Functional Description	67
9.1	LPC Interface	67
9.1.1	LPC Transactions	67
9.1.2	LDRQ# Encoding	67
9.2	Serialized IRQ	67
9.2.1	Continuous Mode	67
9.2.2	Quiet Mode	68
9.2.3	Waveform Samples of SERIRQ Sequence	68
9.2.4	SERIRQ Sampling Slot	69
9.3	General Purpose I/O	70
9.4	Advanced Power Supply Control and Power Management Event (PME#)	72
9.5	Environment Controller	73
9.5.1	Interfaces	73
9.5.2	Registers	73
9.5.2.1	Address Port (Base+05h, Default=00h)	73
9.5.2.2	Register Description	77
9.5.2.2.1	Configuration Register (Index=00h, Default=18h)	77
9.5.2.2.2	Interrupt Status Register 1 (Index=01h, Default=00h)	77
9.5.2.2.3	Interrupt Status Register 2 (Index=02h, Default=00h)	77
9.5.2.2.4	Interrupt Status Register 3 (Index=03h, Default=00h)	77
9.5.2.2.5	SMI# Mask Register 1 (Index=04h, Default=00h)	77
9.5.2.2.6	SMI# Mask Register 2 (Index=05h, Default=00h)	78
9.5.2.2.7	SMI# Mask Register 3 (Index=06h, Default=00h)	78
9.5.2.2.8	Interrupt Mask Register 1 (Index=07h, Default=00h)	78
9.5.2.2.9	Interrupt Mask Register 2 (Index=08h, Default=00h)	78
9.5.2.2.10	Interrupt Mask Register 3 (Index=09h, Default=00h)	78
9.5.2.2.11	Fan Tachometer Divisor Register (Index=0Bh, Default=09h)	79
9.5.2.2.12	Fan Tachometer 1-3 Reading Registers (Index=0Dh-0Fh)	79
9.5.2.2.13	Fan Tachometer 1-3 Limit Registers (Index=10h-12h)	79
9.5.2.2.14	Fan Controller Main Control Register (Index=13h, Default=00h)	79
9.5.2.2.15	FAN_CTL Control Register (Index=14h, Default=00h)	79
9.5.2.2.16	FAN_CTL1 PWM Control Register (Index=15h, Default=00h)	80
9.5.2.2.17	FAN_CTL2 PWM Control Register (Index=16h, Default=00h)	80
9.5.2.2.18	FAN_CTL3 PWM Control Register (Index=17h, Default=00h)	80
9.5.2.2.19	VIN7-VIN0 Voltage Reading Registers (Index=27h-20h)	80
9.5.2.2.20	VBAT Voltage Reading Register (Index=28h)	80
9.5.2.2.21	TMPIN3-1 Temperature Reading Registers (Index=2Bh-29h)	81
9.5.2.2.22	VIN7-0 High Limit Registers (Index=3Eh, 3Ch, 3Ah, 38h, 36h, 34h, 32h, 30h)	81
9.5.2.2.23	VIN7-0 Low Limit Registers (Index=3Fh, 3Dh, 3Bh, 39h, 37h, 35h, 33h, 31h)	81
9.5.2.2.24	TMPIN3-1 High Limit Registers (Index=44h, 42h, 40h)	81
9.5.2.2.25	TMPIN3-1 Low Limit Registers (Index=45h, 43h, 41h)	81
9.5.2.2.26	ADC Voltage Channel Enable Register (Index=50h, Default=00h)	81
9.5.2.2.27	ADC Temperature Channel Enable Register (Index=51h, Default=00h)	81

	81
9.5.2.2.28	TMPIN3-1 Thermal Output Limit Registers (Index=54h-52h, Default=7Fh) 81
9.5.2.2.29	Vendor ID Register (Index=58h, Default=90h) 81
9.5.2.2.30	Thermal Diode Zero Degree Adjust Register (Index=59h, Default=56h) 81
9.5.2.2.31	Beep Event Enable Register (Index=5Ch, Default=00h) 82
9.5.2.2.32	Beep Frequency Divisor of Fan Event Register (Index=5Dh, Default=00h) 82
9.5.2.2.33	Beep Frequency Divisor of Voltage Event Register (Index=5Eh, Default=00h) 82
9.5.2.2.34	Beep Frequency Divisor of Temperature Event Register (Index=5Fh, Default=00h) 82
9.5.2.2.35	FAN_CTL3-1 SmartGuardian Automatic Mode Temperature Limit of OFF Registers (Index=70h, 68h, 60h, Default=7Fh)..... 82
9.5.2.2.36	FAN_CTL3-1 SmartGuardian Automatic Mode Temperature Limit of Low Speed Registers (Index=71h, 69h, 61h, Default=7Fh)..... 82
9.5.2.2.37	FAN_CTL3-1 SmartGuardian Automatic Mode Temperature Limit of Medium Speed Registers (Index=72h, 6Ah, 62h, Default=7Fh) 83
9.5.2.2.38	FAN_CTL3-1 SmartGuardian Automatic Mode Temperature Limit of High Speed Registers (Index=73h, 6Bh, 63h, Default=7Fh)..... 83
9.5.2.2.39	FAN_CTL3-1 SmartGuardian Automatic Mode Over Temperature Limit Registers (Index=74h, 6Ch, 64h, Default=7Fh) 83
9.5.2.2.40	FAN_CTL3-1 SmartGuardian Automatic Mode Low Speed PWM Registers (Index=75h, 6Dh, 65h, Default=00h)..... 83
9.5.2.2.41	FAN_CTL3-1 SmartGuardian Automatic Mode Medium Speed PWM Registers (Index=76h, 6Eh, 66h, Default=00h)..... 83
9.5.2.2.42	FAN_CTL3-1 SmartGuardian Automatic Mode High Speed PWM Registers (Index=77h, 6Fh, 67h, Default=00h) 83
9.5.3	Operation 83
9.5.3.1	Power On RESET and Software RESET 83
9.5.3.2	Starting Conversion..... 84
9.5.3.3	Voltage and Temperature Inputs..... 85
9.5.3.4	Layout and Grounding..... 85
9.5.3.5	Fan Tachometer..... 85
9.5.3.6	Interrupt of the EC..... 86
9.5.3.7	FAN Controller FAN_CTL's ON-OFF and SmartGuardian Modes..... 87
9.6	Floppy Disk Controller (FDC) 87
9.6.1	Introduction 88
9.6.2	Reset..... 88
9.6.3	Hardware Reset (LRESET# Pin) 89
9.6.4	Software Reset (DOR Reset and DSR Reset) 89
9.6.5	Digital Data Separator..... 89
9.6.6	Write Precompensation 89
9.6.7	Data Rate Selection 89
9.6.8	Status, Data and Control Registers 90
9.6.8.1	Digital Output Register (DOR, FDC Base Address + 02h)..... 90
9.6.8.2	Tape Drive Register (TDR, FDC Base Address + 03h) 90
9.6.8.3	Main Status Register (MSR, FDC Base Address + 04h) 91
9.6.8.4	Data Rate Select Register (DSR, FDC Base Address + 04h)..... 92
9.6.8.5	Data Register (FIFO, FDC Base Address + 05h)..... 93
9.6.8.6	Digital Input Register (DIR, FDC Base Address + 07h) 93

9.6.8.7	Diskette Control Register (DCR, FDC Base Address + 07h)	93
9.6.9	Controller Phases	93
9.6.9.1	Command Phase	93
9.6.9.2	Execution Phase	94
9.6.9.3	Result Phase	94
9.6.9.4	Result Phase Status Registers	94
9.6.10	Command Set	96
9.6.11	Data Transfer Commands	112
9.6.11.1	Read Data	112
9.6.11.2	Read Deleted Data	112
9.6.11.3	Read A Track	112
9.6.11.4	Write Data	113
9.6.11.5	Write Deleted Data	113
9.6.11.6	FORMAT A TRACK	113
9.6.11.7	SCAN	113
9.6.11.8	VERIFY	115
9.6.12	Control Commands	115
9.6.12.1	Read ID	115
9.6.12.2	Configure	116
9.6.12.3	Re-Calibrate	116
9.6.12.4	Seek	116
9.6.12.5	Relative Seek	116
9.6.12.6	Dumpreg	117
9.6.12.7	Lock	117
9.6.12.8	Version	117
9.6.12.9	Sense Interrupt Status	117
9.6.12.10	Sense Drive Status	117
9.6.12.11	Specify	118
9.6.12.12	Perpendicular Mode	118
9.6.12.13	Invalid	119
9.6.13	DMA Transfers	119
9.6.14	Low Power Mode	119
9.7	Serial Port (UART) Description	120
9.7.1	Data Registers	120
9.7.2	Control Registers: IER, IIR, FCR, DLL, DLM, LCR and MCR	121
9.7.3	Status Registers: LSR and MSR	126
9.7.4	Reset	128
9.7.5	Programming	129
9.7.6	Software Reset	129
9.7.7	Clock Input Operation	129
9.7.8	FIFO Interrupt Mode Operation	129
9.8	Smart Card Reader	130
9.8.1	Features	130
9.8.2	Operation	130
9.8.3	Connection of IFD to ICC Socket	130
9.8.4	Baud Rate Relationship Between UART and Smart Card Interface	131
9.8.5	Waveform Relationship	132
9.8.6	Clock Divider	132
9.8.7	Waveform Example of Activation/Deactivation Sequence	132
9.8.8	ATR and PTS Structure	133
9.8.9	Smart Card Operating Sequence Example	134
9.9	Parallel Port	135

9.9.1	SPP and EPP Modes	135
9.9.2	EPP Mode Operation	137
9.9.3	ECP Mode Operation	138
9.10	Keyboard Controller (KBC).....	144
9.10.1	Host Interface.....	145
9.10.2	Data Registers and Status Register.....	146
9.10.3	Keyboard and Mouse Interface.....	146
9.10.4	KIRQ and MIRQ.....	146
9.11	Consumer Remote Control (TV Remote) IR (CIR).....	146
9.11.1	Overview	146
9.11.2	Features	146
9.11.3	Block Diagram	147
9.11.4	Transmit Operation	147
9.11.5	Receive Operation	148
9.11.6	Register Descriptions and Address	148
9.11.6.1	CiR Data Register (DR)	148
9.11.6.2	CiR Interrupt Enable Register (IER).....	149
9.11.6.3	CiR Receiver Control Register (RCR).....	150
9.11.6.4	CiR Transmitter Control Register 1 (TCR1).....	151
9.11.6.5	CiR Transmitter Control Register (TCR2).....	152
9.11.6.6	CiR Baud Rate Divisor Low Byte Register (BDLR)	155
9.11.6.7	CiR Baud Rate Divisor High Byte Register (BDHR).....	155
9.11.6.8	CiR Transmitter Status Register (TSR)	155
9.11.6.9	CiR Receiver FIFO Status Register (RSR).....	156
9.11.6.10	CiR Interrupt Identification Register (IIR).....	156
9.12	Game Port Interface	156
9.12.1	Game Port (Base+0h).....	157
9.13	MIDI Interface.....	157
9.13.1	MPU-401 Register Interface	157
9.13.2	Operation	157
9.14	Memory Stick Host Controller.....	158
9.14.1	Overview	158
9.14.2	Features	158
9.14.3	Register Descriptions.....	159
9.14.3.1	MS Command 1 Register.....	159
9.14.3.2	MS Command 2 Register.....	159
9.14.3.3	MS Status Register	160
9.14.3.4	MS Control Register	160
9.14.3.5	MS Receive Data Buffer Register	160
9.14.3.6	MS Transmit Data Buffer Register	161
9.14.3.7	MS ACMD Register	161
9.14.3.8	MS Interrupt Control Register	162
9.14.3.9	MS Interrupt Data Register	163
9.15	SD Host Controller.....	163
9.15.1	Overview	163
9.15.2	Features	163
9.15.3	Register Descriptions.....	164
9.15.3.1	SD Command Register (SD_CMD)	166
9.15.3.2	SD Command Mode Register (SD_CMD_MD).....	166
9.15.3.3	SD Port Selection Register (SD_PORTSEL)	167
9.15.3.4	SD Command Argument Register (SD_ARG4, SD_ARG3, SD_ARG2, and SD_ARG1)	

.....	167
9.15.3.5 Data Stop Register (SD_STOP).....	168
9.15.3.6 Transfer Sector Counter Enable Register (SD_SEC_EN).....	168
9.15.3.7 Transfer Sector Count Register (SD_SECCNTL and SD_SECCNTH).....	168
9.15.3.8 SD Memory Card Response Register (SD_RSP0 – SD_RSP14).....	169
9.15.3.9 SD Memory Card Information Register (SD_INFOL and SD_INFOH).....	171
9.15.3.10 SD Memory Card Buffer Status Register (SD_BUFSTS)	172
9.15.3.11 SD Memory Card Error Register (SD_ERR)	172
9.15.3.12 SD Memory Card Information Mask Register (SD_INFOL_MASK and SD_INFOH_MASK)	174
9.15.3.13 SD Memory Card Buffer Status Mask Register (SD_BUFSTS_MASK).....	174
9.15.3.14 SD Memory Card Error Mask Register (SD_ERR_MASK)	175
9.15.3.15 SD Clock Enable Register (SD_CLKEN)	175
9.15.3.16 SD Clock Divisor Register (SD_CLK_DIV)	176
9.15.3.17 SD Transfer Data Length Register (SD_SIZEL and SD_SIZEH).....	176
9.15.3.18 SD Access Control Option Register (SD_OPTION).....	178
9.15.3.19 SD Data Width Register (SD_DATA_SEL)	178
9.15.3.20 SD CMD and END Error Status Register (SD_CMD_END_ERR_STS).....	179
9.15.3.21 SD CRC Error Status Register (SD_CRC_ERR_STS).....	179
9.15.3.22 SD Timeout Error Status Register (SD_TIMEOUT_ERR_STS).....	179
9.15.3.23 SD Buffer Read/Write Port Register (SD_BUFL and SD_BUFH).....	180
9.15.3.24 SDIO Mode Control Register (SD_MODE1 and SD_MODE2)	181
9.15.3.25 SD IO Card Information Register (SDIO_INFOL and SDIO_INFOH)	183
9.15.3.26 SDIO Card Information Mask Register (SDIO_INFOL_MASK and SDIO_INFOH_MASK)	184
9.15.3.27 DMA Enable Register (DMA_EN)	184
9.15.3.28 Software Reset Register (SOFT_RST).....	184
9.15.3.29 Controller Version Register (VERSION)	185
9.15.3.30 SD Card I/F Power Register (Power Control)	185
9.15.3.31 SD IO Card Information for Port 1 Register (EXT_SDIO).....	185
9.15.3.32 SDIO Card Information Mask for Port 1 Register (EXT_SDIO MASK).....	186
9.15.3.33 Write Protect for Port 1 Register (EXT_WP)	186
9.15.3.34 Card Detect with SDB_DAT3 Register (EXT_CD_DAT3).....	186
9.15.3.35 Card Detect with SDB_DAT3 Mask Register (EXT_CD_DAT3_MASK).....	187
10. DC Electrical Characteristics	189
11. AC Characteristics (VCC = 5V ± 5%, Ta = 0°C to + 70°C)	193
11.1 Clock Input Timings.....	193
11.2 LCLK (PCICLK) and LRESET Timings	193
11.3 LPC and SERIRQ Timings	194
11.4 Serial Port, ASKIR, SIR and Consumer Remote Control Timings.....	195
11.5 Modem Control Timings.....	195
11.6 Floppy Disk Drive Timings.....	195
11.7 EPP Address or Data Write Cycle Timings	197
11.8 EPP Address or Data Read Cycle Timings	198
11.9 ECP Parallel Port Forward Timings.....	198
11.10 ECP Parallel Port Backward Timings.....	199
12. Package Information	201
13. Ordering Information	203

FIGURES

Figure 7-1. IT8722F Special Applications Circuitry for Intel ICH.....	27
Figure 9-1. Start Frame Timing.....	68
Figure 9-2. Stop Frame Timing.....	68
Figure 9-3. General Logic of GPIO Function	71
Figure 9-4. Application Example. Resistor should provide approximately 2V at the Analog Inputs.	84
Figure 9-5. Temperature Interrupt Response Diagram	86
Figure 9-6. SmartGuardian Automatic Mode.....	87
Figure 9-7. Smart Card Reader Application.....	131
Figure 9-8. 9600 Baud Rate Example	132
Figure 9-9. Waveform Example of IFD.....	132
Figure 9-10. Keyboard and Mouse Interface	145
Figure 9-11. CIR Block Diagram.....	147
Figure 11-1. Clock Input Timings.....	193
Figure 11-2. LCLK (PCICLK) and LRESET Timings	193
Figure 11-3. LPC and SERIRQ Timings	194
Figure 11-4. Serial Port, ASKIR, SIR and Consumer Remote Control Timings	195
Figure 11-5. Modem Control Timings.....	195
Figure 11-6. Floppy Disk Drive Timings.....	196
Figure 11-7. EPP Address or Data Write Cycle Timings	197
Figure 11-8. EPP Address or Data Read Cycle Timings	198
Figure 11-9. ECP Parallel Port Forward Timings.....	198
Figure 11-10. ECP Parallel Port Backward Timings	199

TABLES

Table 4-1. Pins Listed in Numeric Order.....	8
Table 5-1. Pin Description of Supplies Signals.....	9
Table 6-1. General Purpose I/O Group 1 (Set 1).....	25
Table 6-2. General Purpose I/O Group 2 (Set 2).....	25
Table 6-3. General Purpose I/O Group 3 (Set 3).....	26
Table 6-4. General Purpose I/O Group 4 (Set 4).....	26
Table 6-5. General Purpose I/O Group 5 (Set 5).....	26
Table 7-1. Power On Strapping Options.....	27
Table 8-1. Global Configuration Registers.....	30
Table 8-2. FDC Configuration Registers.....	30
Table 8-3. Serial Port 1 Configuration Registers.....	31
Table 8-4. Serial Port 2 Configuration Registers.....	31
Table 8-5. Parallel Port Configuration Registers.....	31
Table 8-6. Environment Controller Configuration Registers.....	32
Table 8-7. KBC(Keyboard) Configuration Registers.....	32
Table 8-8. KBC(Mouse) Configuration Registers.....	32
Table 8-9. GPIO Configuration.....	33
Table 8-10. GPIO Configuration Registers.....	34
Table 8-11. MIDI Port Configuration Registers.....	35
Table 8-12. Game Port Configuration Registers.....	35
Table 8-13. Consumer IR Configuration Registers.....	35
Table 8-14. Memory Stick Configuration Registers.....	35
Table 8-15. SD Configuration Registers.....	36
Table 8-16. Base Address of Logical Devices.....	36
Table 9-1. Address Map on the LPC Bus.....	73
Table 9-2. Environment Controller Registers.....	74
Table 9-3. Environment Controller Registers.....	76
Table 9-4. Digital Output Register (DOR).....	90
Table 9-5. Tape Drive Register (TDR).....	90
Table 9-6. Main Status Register (MSR).....	91
Table 9-7. Data Rate Select Register (DSR).....	92
Table 9-8. Data Register (FIFO).....	93
Table 9-9. Digital Input Register (DIR).....	93
Table 9-10. Diskette Control Register (DCR).....	93
Table 9-11. Status Register 0 (ST0).....	94
Table 9-12. Status Register 1 (ST1).....	95
Table 9-13. Status Register 2 (ST2).....	96
Table 9-14. Status Register 3 (ST3).....	96

Table 9-15. Command Set Symbol Descriptions	97
Table 9-16. Command Set Summary	98
Table 9-17. Effects of MT and N Bits	112
Table 9-18. SCAN Command Result	114
Table 9-19. VERIFY Command Result	115
Table 9-20. Interrupt Identification	117
Table 9-21. HUT Values	118
Table 9-22. SRT Values	118
Table 9-23. HLT Values	118
Table 9-24. Effects of GAP and WG on FORMAT A TRACK and WRITE DATA Commands	118
Table 9-25. Effects of Drive Mode and Data Rate on FORMAT A TRACK and WRITE DATA Commands ...	119
Table 9-26. Serial Channel Registers	120
Table 9-27. Interrupt Enable Register Description	121
Table 9-28. Interrupt Identification Register	122
Table 9-29. FIFO Control Register Description	123
Table 9-30. Receiver FIFO Trigger Level Encoding	123
Table 9-31. Baud Rates Using (24 MHz ÷ 13) Clock	124
Table 9-32. Line Control Register Description	125
Table 9-33. Stop Bits Number Encoding	125
Table 9-34. Modem Control Register Description	126
Table 9-35. Line Status Register Description	126
Table 9-36. Modem Status Register Description	128
Table 9-37. Reset Control of Registers and Pinout Signals	128
Table 9-38. SCRCLK Selections	132
Table 9-39. Parallel Port Connector in Different Modes	135
Table 9-40. Address Map and Bit Map for SPP and EPP Modes	135
Table 9-41. Bit Map of the ECP Registers	138
Table 9-42. ECP Register Definitions	139
Table 9-43. ECP Mode Descriptions	139
Table 9-44. ECP Pin Descriptions	140
Table 9-45. Extended Control Register (ECR) Mode and Description	142
Table 9-46. Data Register READ/WRITE Controls	145
Table 9-47. Status Register	146
Table 9-48. List of CIR Registers	148
Table 9-49. Modulation Carrier Frequency	153
Table 9-50. Receiver Demodulation Low Frequency (HCFS = 0)	154
Table 9-51. Receiver Demodulation High Frequency (HCFS = 1)	155
Table 9-52. Memory Stick Register List	159
Table 9-53. SD Host Controller Access Port	164

Table 9-54. SD Host Controller Register	164
Table 9-55. SD Data Transfer Data Length	177

1. Features

■ Low Pin Count Interface

- Complies with Intel Low Pin Count Interface Specification Rev. 1.0
- Supports LDRQ#, SERIRQ protocols
- Supports LPCPD#, CLKRUN#, PCI PME# Interfaces

■ PC98/99, ACPI & LANDesk Compliant

- ACPI V. 1.0 compliant
- Register sets compatible with "Plug and Play ISA Specification V. 1.0a"
- LANDesk 3.X compliant
- Supports 12 logical devices

■ Memory Stick Interface

- Memory Stick V1.3 Specifications compliant
- Up to 20MHz interface serial clock
- Support DMA transmission
- Support interrupt polling transmission

■ Secure Digital (SD) Memory Card Interface

- Up to 24MHz interface serial clock
- Forward compatibility to MultiMedia Card
- Support DMA transmission
- 512byte data buffer
- SD Memory/IO card Interface Supported

■ Enhanced Hardware Monitor

- Built-in 8-bit Analog to Digital Converter
- 3 thermal inputs from remote thermal resistor, thermal diode or diode-connected transistor
- 8 voltage monitor inputs (VBAT is measured internally.)
- 1 chassis open detection input with low power Flip-Flop backed by the battery
- Watch Dog comparison of all monitored values
- SM Bus slave mode supported

■ Fan Speed Controller

- Provides fan's power and PWM control
- Supports 3 programmable Pulse Width Modulation (PWM) outputs
- 128 steps of PWM modes
- Monitors 3 fan tachometer inputs

■ SmartGuardian Controller

- Provides programmable fan speed automatic control
- Supports mix-and-match for temperature inputs and fan speed control outputs
- Overrides fan speed control during catastrophic situations
- Provides the beep tone warning when the temperature is over

■ Two 16C550 UARTs

- Supports two standard Serial Ports
- Supports IrDA 1.0/ASKIR protocols
- Supports Smart Card Reader protocols

■ Smart Card Reader

- Compliant with Personal Computer Smart Card (PC/SC) Working Group standard
- Compliant with smart card (ISO 7816) protocols
- Supports card present detect
- Supports Smart Card insert the power-on feature
- Supports one programmable clock frequency, and 7.1 MHz and 3.5 MHz (Default) card clocks

■ Consumer Remote Control (TV remote) IR with Power-up Feature

■ IEEE 1284 Parallel Port

- Standard mode -- Bi-directional SPP compliant
- Enhanced mode -- EPP V. 1.7 and V. 1.9 compliant
- High speed mode -- ECP, IEEE 1284 compliant
- Back-drive current reduction
- Printer power-on damage reduction
- Supports POST (Power-On Self Test) Data Port

■ Floppy Disk Controller

- Supports two 360K/ 720K/ 1.2M/ 1.44M/ 2.88M floppy disk drives
- Enhanced digital data separator
- 3-Mode drives supported
- Supports automatic write protection via software

- **Keyboard Controller**
 - 8042 compatible for PS/2 keyboard and mouse
 - 2KB of custom ROM and 256-byte data RAM
 - GateA20 and Keyboard reset output
 - Supports any key, or 2-5 sequential keys, or 1-3 simultaneous keys keyboard power-on events
 - Supports Mouse Double-click and/or Mouse Move Power on Events
 - Supports the keyboard and mouse I/F hardware auto-swap
- **Game Port**
 - Built-in 558 quad timers and buffer chips
 - Supports direct connection of two joysticks
- **Dedicated MIDI Interface**
 - MPU-401 UART mode compatible
- **38 General Purpose I/O Pins**
 - Input mode supports either switch de-bounce or programmable external IRQ input routing
 - Output mode supports 2 sets of programmable LED blinking periods
- **External IRQ Input Routing Capability**
 - Provides IRQ input routing through GPIO input mode
 - Programmable registers for IRQ routing
- **Watchdog Timer**
 - Time resolution 1 minute or 1 second, maximum 255 minutes or 255 seconds
 - Output to KRST# when expired
- **ITE Innovative Automatic Power-failure Resume and Power Button de-bounce**
- **Dedicated Infrared Pins**
- **VCCH and Vbat Supported**
- **Built-in 32.768 KHz Oscillator**
- **Single 24/48 MHz Clock Input**
- **+5V Power Supply**
- **128-pin QFP**

2. General Description

The IT8722F is a Low Pin Count Interface-based highly integrated Super I/O. The IT8722F provides the most commonly used legacy Super I/O functionality and the latest Environment Control initiatives, such as H/W Monitor, Fan Speed Controller, ITE's "SmartGuardian" function and Smart Card Reader Interface. The device's LPC interface complies with Intel "LPC Interface Specification Rev. 1.0". The IT8722F meets the requirements of Microsoft PC98 & PC99 System Design Guide, and is ACPI & LANDesk compliant.

The IT8722F features the enhanced hardware monitor providing 3 thermal inputs from remote thermal resistors, thermal diode or diode-connected transistor (2N3094). The device also provides the ITE innovative and intelligent automatic fan ON/OFF and speed control functions (SmartGuardian) to protect the system and reduce its noise and power consumption. It also features a PC/SC and ISO 7816 compliant Smart Card Reader.

The Memory Stick Interface complies with Sony Memory Stick Standard Ver 1.3. It supports up to 20MHz clock. The Secure Digital Interface complies with SD-Memory Card Specifications/Part1. Part one physical Layer Specification Ver. 1.0. It supports up to 24MHz clock. Besides the new feature, the IT8722F contains one game port which supports two joysticks, one MIDI port and one Fan Speed Controller. The fan speed controller is responsible to control three fan speeds through three 128-step of Pulse Width Modulation (PWM) output pins and to monitor three FANs' Tachometer inputs. It also features two 16C550 UARTs, one IEEE 1284 Parallel Port, one Floppy Disk Controller and one 8042 Keyboard Controller.

The IT8722F has integrated 13 logical devices. One high-performance 2.88MB floppy disk controller, with digital data separator, supports two 360K/ 720K/ 1.2M/ 1.44M/ 2.88M floppy disk drives. One multi-mode high-performance parallel port features the bi-directional Standard Parallel Port (SPP), the Enhanced Parallel Port (EPP V. 1.7 and EPP V. 1.9 are supported), and the IEEE 1284 compliant Extended Capabilities Port (ECP). Two 16C550 standard compatible enhanced UARTs perform asynchronous communication and support either IR or MIDI interfaces. One game port with built-in 558 quad timers and buffer chips supports direct connection of 2 joysticks. The device also features one MPU-401 UART mode compatible MIDI port, one fan speed controller responsible for controlling / monitoring 3 fans and 5 GPIO ports (38 GPIO pins). The IT8722F also has an integrated 8042 compatible Keyboard Controller with 2KB of programmable ROM for customer application.

These 13 logical devices can be individually enabled or disabled via software configuration registers. The IT8722F utilizes power-saving circuitry to reduce power consumption and the inputs are gated inhibit, the outputs are tri-state and the input clock is disabled once a logical device is disabled. The device requires a single 24/48 MHz clock input and operates with +5V power supply. The IT8722F is available in 128-pin QFP (Quad Flat Package).

3. Block Diagram

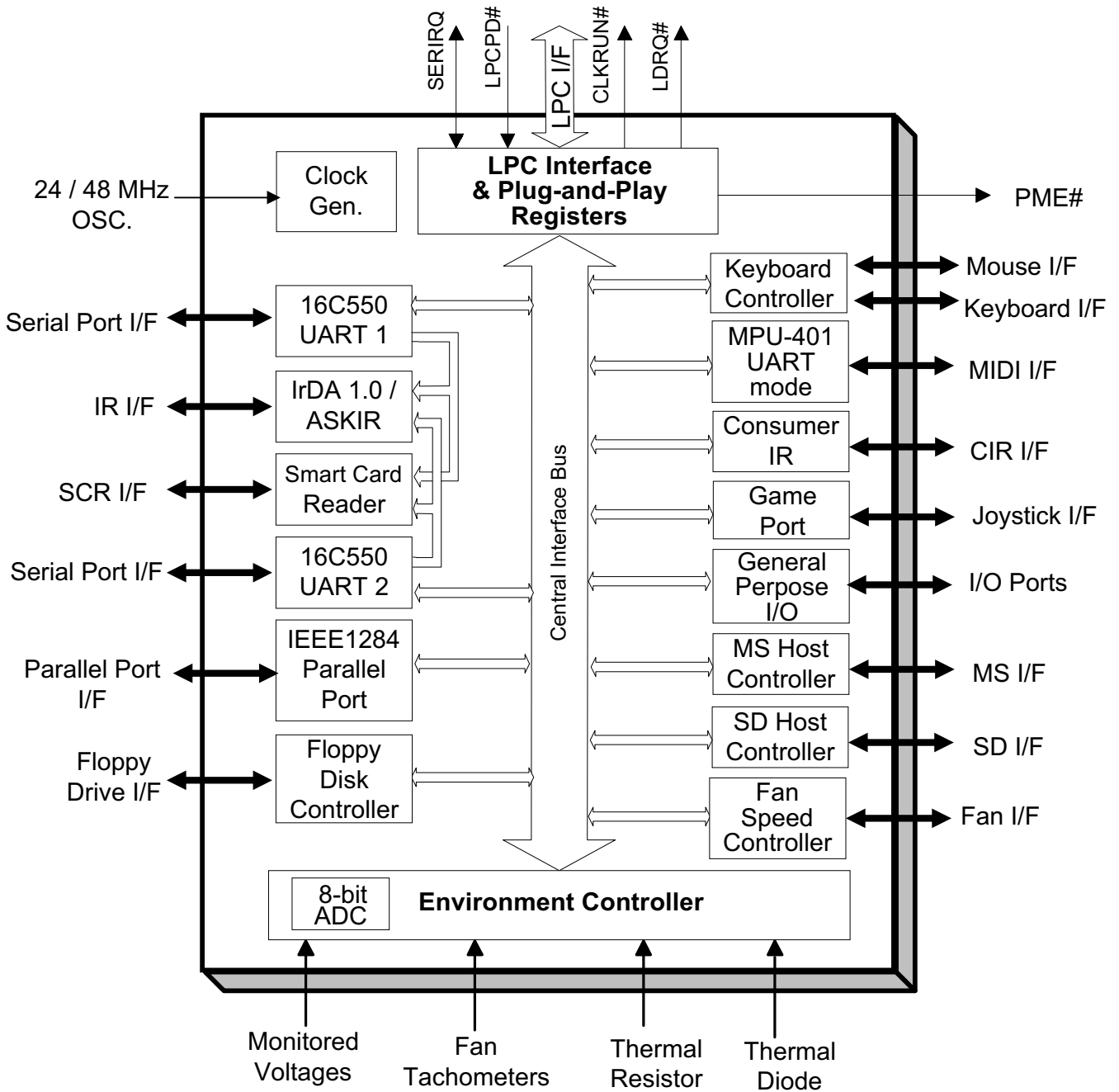

4. Pin Configuration

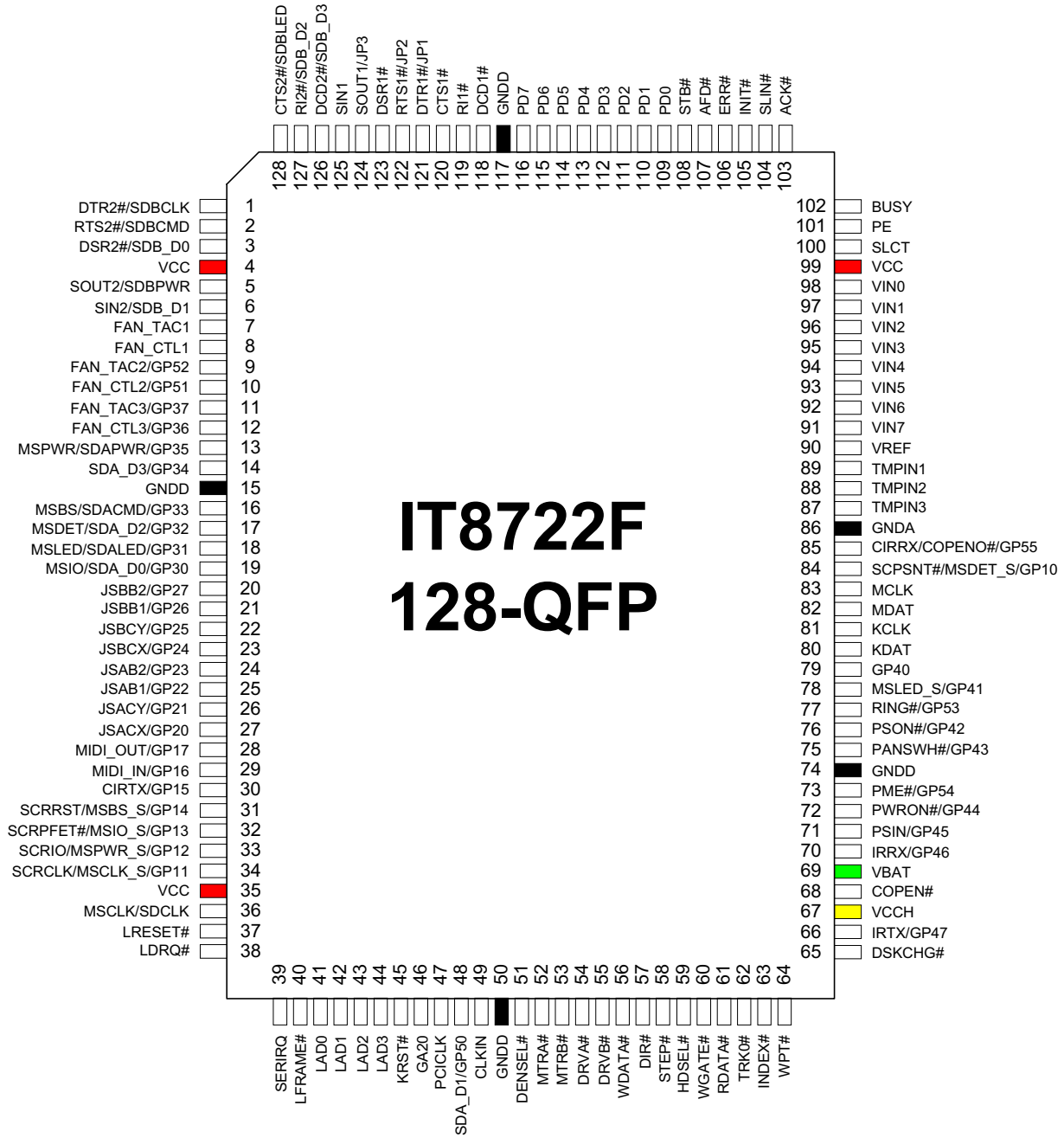

Top View

Table 4-1. Pins Listed in Numeric Order

Pin	Signal	Pin	Signal	Pin	Signal	Pin	Signal
1	DTR2#/ SDBCLK	33	SCRIO/ MSPWR_S/GP12	65	DSKCHG#	97	VIN1
2	RTS2#/SDBCMD	34	SCRCLK/ MSCLK_S/GP11	66	IRTX/GP47	98	VIN0
3	DSR2#/ SDB_D0	35	VCC	67	VCCH	99	VCC
4	VCC	36	MSCLK/SDCLK	68	COPEN#	100	SLCT
5	SOUT2/SDBPWR	37	LRESET#	69	VBAT	101	PE
6	SIN2/SDB_D1	38	LDRQ#	70	IRRX/GP46	102	BUSY
7	FAN_TAC1	39	SERIRQ	71	PSIN/GP45	103	ACK#
8	FAN_CTL1	40	LFRAME#	72	PWRON#/GP44	104	SLIN#
9	FAN_TAC2/GP52	41	LAD0	73	PME#/GP54	105	INIT#
10	FAN_CTL2/GP51	42	LAD1	74	GNDD	106	ERR#
11	FAN_TAC3/GP37	43	LAD2	75	PANSWH#/GP43	107	AFD#
12	FAN_CTL3/GP36	44	LAD3	76	PERSON#/GP42	108	STB#
13	MSPWR/ SDAPWER/GP35	45	KRST#	77	RING#/GP53	109	PD0
14	SDA_D3/GP34	46	GA20	78	MSLED_S/GP41	110	PD1
15	GNDD	47	PCICLK	79	GP40	111	PD2
16	MSBS/SDACMD/ GP33	48	SDA_D1/GP50	80	KDAT	112	PD3
17	MSDET/SDA_D2/ GP32	49	CLKIN	81	KCLK	113	PD4
18	MSLED/SDALED/ GP31	50	GNDD	82	MDAT	114	PD5
19	MSIO/SDA_D0/ GP30	51	DENSEL#	83	MCLK	115	PD6
20	JSBB2/GP27	52	MTRA#	84	SCRPRES#/MSD ET_S/GP10	116	PD7
21	JSBB1/GP26	53	MTRB#	85	CIRRX/COPENO# / GP55	117	GNDD
22	JSBCY/GP25	54	DRVA#	86	GNDA	118	DCD1#
23	JSBCX/GP24	55	DRVB#	87	TMPIN3	119	RI1#
24	JSAB2/GP23	56	WDATA#	88	TMPIN2	120	CTS1#
25	JSAB1/GP22	57	DIR#	89	TMPIN1	121	DTR1#/JP1
26	JSACY/GP21	58	STEP#	90	VREF	122	RTS1#/JP2
27	JSACX/GP20	59	HDSEL#	91	VIN7	123	DSR1#
28	MIDI_OUT/GP17	60	WGATE#	92	VIN6	124	SOUT1/J3
29	MIDI_IN/GP16	61	RDATA#	93	VIN5	125	SIN1
30	CIRTX/GP15	62	TRK0#	94	VIN4	126	DCD2#/ SDB_D3
31	SCRST/ MSBS_S/GP14	63	INDEX#	95	VIN3	127	RI2#/SDB_D2
32	SCRPFET#/ MSIO_S/GP13	64	WPT#	96	VIN2	128	CTS2#/SDBLED

5. IT8722F Pin Descriptions

Table 5-1. Pin Description of Supplies Signals

Pin(s) No.	Symbol	Attribute	Power	Description
4, 35, 99	VCC	PWR	-	+5V Power Supply.
67	VCCH	PWR	-	+5V VCC Help Supply.
69	VBAT	PWR	-	+3.3V Battery Supply.
15, 50, 74, 117	GNDD	GND	-	Digital Ground.
86	GNDA	GND	-	Analog Ground.

Table 5-2. Pin Description of LPC Bus Interface Signals

Pin(s) No.	Symbol	Attribute	Power	Description
38	LDRQ#	DO16	VCC	LPC DMA Request #. An encoded signal for DMA channel select.
40	LFRAME#	DI	VCC	LPC Frame #. This signal indicates the start of LPC cycle.
37	LRESET#	DI	VCC	LPC RESET #.
39	SERIRQ	DIO16	VCC	Serial IRQ.
41 – 44	LAD[0:3]	DIO16	VCC	LPC Address/Data 0 - 3. 4-bit LPC address/bi-directional data lines. LAD0 is the LSB and LAD3 is the MSB.
47	PCICLK	DI	VCC	PCI Clock. 33 MHz PCI clock input for LPC I/F and SERIRQ.
73	PME#/GP54	DOD8/ DIOD8	VCCH	Power Management Event # / General Purpose I/O 54. <ul style="list-style-type: none"> The first function of this pin is the power management event #. It supports the PCI PME# interface. This signal allows the peripheral to request the system to wake up from the D3 (cold) state. The second function of this pin is the General Purpose I/O Port 5 Bit 4. The function configuration of this pin is determined by programming the software configuration registers.

Table 5-3. Pin Description of MIDI Interface Signals

Pin(s) No.	Symbol	Attribute	Power	Description
28	MIDI_OUT/ GP17	DO8/ DIOD8	VCC	MIDI Output / General Purpose I/O 17. <ul style="list-style-type: none"> The first function of this pin is MIDI Output. The second function of this pin is the General Purpose I/O Port 1 Bit 7. The function configuration of this pin is determined by programming the software configuration registers.
29	MIDI_IN/ GP16	DI/ DIOD8	VCC	MIDI Input / General Purpose I/O 16. <ul style="list-style-type: none"> The first function of this pin is MIDI Input. The second function of this pin is the General Purpose I/O Port 1 Bit 6. The function configuration of this pin is determined by programming the software configuration registers.

Table 5-4. Pin Description of Game Port Signals

Pin(s) No.	Symbol	Attribute	Power	Description
27	JSACX/ GP20	DIOD8/ DIOD8	VCC	Joystick A Coordinate X / General Purpose I/O 20. <ul style="list-style-type: none"> The first function of this pin is Joystick A Coordinate X. The second function of this pin is the General Purpose I/O Port 2 Bit 0. The function configuration of this pin is determined by programming the software configuration registers.
26	JSACY/ GP21	DIOD8/ DIOD8	VCC	Joystick A Coordinate Y / General Purpose I/O 21. <ul style="list-style-type: none"> The first function of this pin is Joystick A Coordinate Y. The second function of this pin is the General Purpose I/O Port 2 Bit 1. The function configuration of this pin is determined by programming the software configuration registers.
25	JSAB1/ GP22	DI/ DIOD8	VCC	Joystick A Button 1 / General Purpose I/O 22. <ul style="list-style-type: none"> The first function of this pin is Joystick A Button 1. The second function of this pin is the General Purpose I/O Port 2 Bit 2. The function configuration of this pin is determined by programming the software configuration registers.
24	JSAB2/ GP23	DI/ DIOD8	VCC	Joystick A Button 2 / General Purpose I/O 23. <ul style="list-style-type: none"> The first function of this pin is Joystick A Button 2. The second function of this pin is the General Purpose I/O Port 2 Bit 3. The function configuration of this pin is determined by programming the software configuration registers.
23	JSBCX/ GP24	DIOD8/ DIOD8	VCC	Joystick B Coordinate X / General Purpose I/O 24. <ul style="list-style-type: none"> The first function of this pin is Joystick B Coordinate X. The second function of this pin is the General Purpose I/O Port 2 Bit 4. The function configuration of this pin is determined by programming the software configuration registers.
22	JSBCY/ GP25	DIOD8/ DIOD8	VCC	Joystick B Coordinate Y / General Purpose I/O 25. <ul style="list-style-type: none"> The first function of this pin is Joystick B Coordinate Y. The second function of this pin is the General Purpose I/O Port 2 Bit 5. The function configuration of this pin is determined by programming the software configuration registers.
21	JSBB1/ GP26	DI/ DIOD8	VCC	Joystick B Button 1 / General Purpose I/O 26. <ul style="list-style-type: none"> The first function of this pin is Joystick B Button 1. The second function of this pin is the General Purpose I/O Port 2 Bit 6. The function configuration of this pin is determined by programming the software configuration registers.

Table 5-4. Pin Description of Game Port Signals [cont'd]

Pin(s) No.	Symbol	Attribute	Power	Description
20	JSBB2/ GP27	DI/ DIOD8	VCC	Joystick B Button 2 / General Purpose I/O 27. <ul style="list-style-type: none"> The first function of this pin is Joystick B Button 2. The second function of this pin is the General Purpose I/O Port 2 Bit 7. The function configuration of this pin is determined by programming the software configuration registers.

Table 5-5. Pin Description of Hardware Monitor Signals^{Note1}

Pin(s) No.	Symbol	Attribute	Power	Description
98 – 91	VIN[0:7]	AI	VCC	Voltage Analog Inputs [0:7]. 0 to 4.096V FSR Analog Inputs.
90	VREF	AO	VCC	Reference Voltage Output. Regulated and referenced voltage for 3 external temperature sensors and negative voltage monitor.
89 – 87	TMPIN[1:3]	AI	VCC	External Thermal Inputs [1:3]. Connected to thermistors [1:3] or thermal temperature sensors and negative voltage monitor.
7	FAN_TAC1	DI	VCC	Fan Tachometer Input 1. 0 to +5V amplitude fan tachometer input.
9	FAN_TAC2/ GP52	DI/ DIOD8	VCC	Fan Tachometer Input 2 / General Purpose I/O 52. <ul style="list-style-type: none"> The first function of this pin is Fan Tachometer Input 2. 0 to +5V amplitude fan tachometer input. The second function of this pin is the General Purpose I/O Port 5 Bit 2. The function configuration of this pin is determined by programming the software configuration registers.
11	FAN_TAC3/ GP37	DI/ DIOD8	VCC	Fan Tachometer Input 3 / General Purpose I/O 37. <ul style="list-style-type: none"> The first function of this pin is Fan Tachometer Input 3. 0 to +5V amplitude fan tachometer input. The second function of this pin is the General Purpose I/O Port 5 Bit 2. The function configuration of this pin is determined by programming the software configuration registers.
68	COPEN#	DIOD8	VCCH or VBAT	Case Open Detection #. <ul style="list-style-type: none"> The Case Open Detection is connected to a specially designed low power CMOS flip-flop backed by the battery for case open state preservation during power loss.

Table 5-6. Pin Description of Fan Controller Signals

Pin(s) No.	Symbol	Attribute	Power	Description
8	FAN_CTL1	DOD8	VCC	Fan Control Output 1. (PWM output signal to Fan's FET.)
10	FAN_CTL2/ GP51	DOD8/ DIOD8	VCC	Fan Control Output 2 / General Purpose I/O 51. <ul style="list-style-type: none"> The first function of this pin is Fan Control Output 2. (PWM output signal to Fan's FET.) The second function of this pin is the General Purpose I/O Port 5 Bit 1. The function configuration of this pin is determined by programming the software configuration registers.

Table 5-6. Pin Description of Fan Controller Signals [cont'd]

Pin(s) No.	Symbol	Attribute	Power	Description
12	FAN_CTL3/ GP36	DOD8/ DIOD8	VCC	Fan Control Output 3 / General Purpose I/O 36. <ul style="list-style-type: none"> The first function of this pin is Fan Control Output 3. (PWM output signal to Fan's FET.) The second function of this pin is the General Purpose I/O Port 3 Bit 6. The function configuration of this pin is determined by programming the software configuration registers.

Table 5-7. Pin Description of Infrared Port Signals

Pin(s) No.	Symbol	Attribute	Power	Description
30	CIRTX/ GP15	DOD8/ DIOD8	VCC	Consumer Infrared Transmit Output / General Purpose I/O 15. <ul style="list-style-type: none"> The first function of this pin is Consumer Infrared Transmit Output. The second function of this pin is the General Purpose I/O Port 1 Bit 5. The function configuration of this pin is determined by programming the software configuration registers.
85	CIRRX/ COPENO#/ GP55	DI/ DOD8/ DIOD8	VCCH	Consumer Infrared Receive Input / Case Open Output # / General Purpose I/O 55. <ul style="list-style-type: none"> The first function of this pin is Consumer Infrared Receive Input or Case Open Output #, which is decided by the software register (LDN4, Index F4h, bit6). If the bit is set to 1 (selecting COPENO#), it will output low when COPEN# is detected low. The second function of this pin is the General Purpose I/O Port 5 Bit 5. The function configuration of this pin is determined by programming the software configuration registers.
70	IRRX/ GP46	DI/ DIOD8	VCCH	Infrared Receive Input / General Purpose I/O 46. <ul style="list-style-type: none"> The first function of this pin is Infrared Receive Input. The second function of this pin is the General Purpose I/O Port 4 Bit 6. The function configuration of this pin is determined by programming the software configuration registers.
66	IRTX/ GP47	DO8/ DIOD8	VCC	Infrared Transmit Output / General Purpose I/O 47. <ul style="list-style-type: none"> The first function of this pin is Infrared Transmit output. The second function of this pin is the General Purpose I/O Port 4 Bit 7. The function configuration of this pin is determined by programming the software configuration registers.

Table 5-8. Pin Description of Serial Port 1 Signals

Pin(s) No.	Symbol	Attribute	Power	Description
125	SIN1	DI	VCC	Serial Data Input 1. This input receives serial data from the communications link.
124	SOUT1/ JP3	DO8/ DI	VCC	Serial Data Output 1. This output sends serial data to the communications link. This signal is set to a marking state (logic 1) after a Master Reset operation or when the device is in one of the Infrared communications modes. During LRESET#, this pin is input for JP3 power-on strapping option
123	DSR1#	DI	VCC	Data Set Ready 1 #. When the signal is low, it indicates that the MODEM or data set is ready to establish a communications link. The DSR# signal is a MODEM status input whose condition can be tested by reading the MSR register.
122	RTS1#/ JP2	DO8/ DI	VCC	Request to Send 1 #. When this signal is low, this output indicates to the MODEM or data set that the device is ready to send data. RTS# is activated by setting the appropriate bit in the MCR register to 1. After a Master Reset operation or during Loop mode, RTS# is set to its inactive state. <u>During LRESET#, this pin is input for JP2 power-on strapping option</u>
121	DTR1#/ JP1	DO8/ DI	VCC	Data Terminal Ready 1 #. DTR# is used to indicate to the MODEM or data set that the device is ready to exchange data. DTR# is activated by setting the appropriate bit in the MCR register to 1. After a Master Reset operation or during Loop mode, DTR# is set to its inactive state. <u>During LRESET#, this pin is input for JP1 power-on strapping option</u>
120	CTS1#	DI	VCC	Clear to Send 1 #. When the signal is low, it indicates that the MODEM or data set is ready to accept data. The CTS# signal is a MODEM status input whose condition can be tested by reading the MSR register.
119	RI1#	DI	VCC	Ring Indicator 1 #. When the signal is low, it indicates that a telephone ring signal has been received by the MODEM. The RI# signal is a MODEM status input whose condition can be tested by reading the MSR register.
118	DCD1#	DI	VCC	Data Carrier Detect 1 #. When the signal is low, it indicates that the MODEM or data set has detected a carrier. The DCD# signal is a MODEM status input whose condition can be tested by reading the MSR register.

Table 5-9. Pin Description of Serial Port 2 Signals

Pin(s) No.	Symbol	Attribute	Power	Description
6	SIN2/ SDB_D1	DI/ DIO8	VCC	Serial Data Input 2 / SD I/F B Data 1. <ul style="list-style-type: none"> The first function of this pin is Serial Data Input 2. This input receives serial data from the communications link. The second function of this pin is SD I/F B Data 1. The function configuration of this pin is determined by programming the software configuration registers.
5	SOUT2/ SDBPWR	DO8/ DOD8	VCC	Serial Data Output 2 / SD I/F B Power FET Control. <ul style="list-style-type: none"> The first function of this pin is Serial Data Output 2. This output sends serial data to the communications link. This signal is set to a marking state (logic 1) after a Master Reset operation or when the device is in one of the Infrared communications modes. The second function of this pin is SD I/F B Power FET Control. The function configuration of this pin is determined by programming the software configuration registers.
3	DSR2#/ SDB_D0	DI/ DIO8	VCC	Data Set Ready 2 # / SD I/F B Data 0. <ul style="list-style-type: none"> The first function of this pin is Data Set Ready 2 #. When the signal is low, it indicates that the MODEM or data set is ready to establish a communications link. The DSR# signal is a MODEM status input whose condition can be tested by reading the MSR register. The second function of this pin is SD I/F B Data 0. The function configuration of this pin is determined by programming the software configuration registers.
2	RTS2#/ SDBCMD	DO8/ DIO8	VCC	Request to Send 2 # / SD I/F B Command. <ul style="list-style-type: none"> The first function of this pin is Request to Send 2 #. When this signal is low, this output indicates to the MODEM or data set that the device is ready to send data. RTS# is activated by setting the appropriate bit in the MCR register to 1. After a Master Reset operation or during Loop mode, RTS# is set to its inactive state. The second function of this pin is SD I/F B Command. The function configuration of this pin is determined by programming the software configuration registers.
1	DTR2#/ SDBCLK	DO8/ DO8	VCC	Data Terminal Ready 2 # / SD I/F B Clock. <ul style="list-style-type: none"> The first function of this pin is Data Terminal Ready 2 #. DTR# is used to indicate to the MODEM or data set that the device is ready to exchange data. DTR# is activated by setting the appropriate bit in the MCR register to 1. After a Master Reset operation or during Loop mode, DTR# is set to its inactive state. The second function of this pin is SD I/F B Clock. The function configuration of this pin is determined by programming the software configuration registers.

Table5-9. Pin Description of Serial Port 2 Signals [cont'd]

Pin(s) No.	Symbol	Attribute	Power	Description
128	CTS2#/ SDBLED	DI/ DOD8	VCC	Clear to Send 2 # / SD I/F B LED. <ul style="list-style-type: none"> The first function of this pin is Clear to Send 2 #. When the signal is low, it indicates that the MODEM or data set is ready to accept data. The CTS# signal is a MODEM status input whose condition can be tested by reading the MSR register. The second function of this pin is SD I/F B LED. The function configuration of this pin is determined by programming the software configuration registers.
127	RI2#/ SDB_D2	DI/ DIO8	VCC	Ring Indicator 2 # / SD I/F B Data 2. <ul style="list-style-type: none"> The first function of this pin is Ring Indicator 2 #. When the signal is low, it indicates that a telephone ring signal has been received by the MODEM. The RI# signal is a MODEM status input whose condition can be tested by reading the MSR register. The second function of this pin is SD I/F B Data 2. The function configuration of this pin is determined by programming the software configuration registers.
126	DCD2#/ SDB_D3	DI/ DIO8	VCC	Data Carrier Detect 2 # / SD I/F B Data 3. <ul style="list-style-type: none"> The first function of this pin is Data Carrier Detect 2 #. When the signal is low, it indicates that the MODEM or data set has detected a carrier. The DCD# signal is a MODEM status input whose condition can be tested by reading the MSR register. The second function of this pin is SD I/F B Data 3. The function configuration of this pin is determined by programming the software configuration registers.

Table 5-10. Pin Description of Parallel Port Signals

Pin(s) No.	Symbol	Attribute	Power	Description
100	SLCT	DI	VCC	Printer Select. This signal goes high when the line printer has been selected.
101	PE	DI	VCC	Printer Paper End. This signal is set high by the printer when it runs out of paper.
102	BUSY	DI	VCC	Printer Busy. This signal goes high when the line printer has a local operation in progress and cannot accept data.
103	ACK#	DI	VCC	Printer Acknowledge #. This signal goes low to indicate that the printer has already received a character and is ready to accept another one.
104	SLIN#	DIO24	VCC	Printer Select Input #. When the signal is low, the printer is selected. This signal is derived from the complement of bit 3 of the printer control register.
105	INIT#	DIO24	VCC	Printer Initialize #. When the signal is low, the printer is selected. This signal is derived from the complement of bit 3 of the printer control register.
106	ERR#	DI	VCC	Printer Error #. When the signal is low, it indicates that the printer has encountered an error. The error message can be read from bit 3 of the printer status register.
107	AFD#	DIO24	VCC	Printer Auto Line Feed #. When the signal is low, it is derived from the complement of bit 1 of the printer control register and is used to advance one line after each line is printed.
108	STB#	DI	VCC	Printer Strobe #. When the signal is low, it is the complement of bit 0 of the printer control register and is used to strobe the printing data into the printer.
109 – 116	PD[0:7]	DIO24	VCC	Parallel Port Data [0:7]. This bus provides a byte-wide input or output to the system. The eight lines are held in a high impedance state when the port is deselected.

Table 5-11. Pin Description of Floppy Disk Controller Signals

Pin(s) No.	Symbol	Attribute	Power	Description
51	DENSEL#	DO40	VCC	FDD Density Select #. DENSEL# is high for high data rates (500 Kbps, 1 Mbps). DENSEL# is low for low data rates (250 Kbps, 300 Kbps).
52	MTRA#	DO40	VCC	FDD Motor A Enable #. This signal is active low.
53	MTRB#	DO40	VCC	FDD Motor B Enable #. This signal is active low.
54	DRVA#	DO40	VCC	FDD Drive A Enable #. This signal is active low.
55	DRVB#	DO40	VCC	FDD Drive B Enable #. This signal is active low.
56	WDATA#	DO40	VCC	FDD Write Serial Data to the Drive #. This signal is active low.
57	DIR#	DO40	VCC	FDD Head Direction #. Step in when this signal is low and step out when high during a SEEK operation.
58	STEP#	DO40	VCC	FDD Step Pulse #. This signal is active low.
59	HDSEL#	DO40	VCC	FDD Head Select #. This signal is active low.
60	WGATE#	DO40	VCC	FDD Write Gate Enable #. This signal is active low.
61	RDATA#	DI	VCC	FDD Read Disk Data #. This signal is active low. It is serial data input from FDD.
62	TRK0#	DI	VCC	FDD Track 0 #. This signal is active low. It indicates that the head of the selected drive is on track 0.
63	INDEX#	DI	VCC	FDD Index #. This signal is active low. It indicates the beginning of a disk track.
64	WPT#	DI	VCC	FDD Write Protect #. This signal is active low. It indicates that the disk of the selected drive is write-protected.
65	DSKCHG#	DI	VCC	FDD Disk Change #. This signal is active low. It senses whether the drive door has been opened or a diskette has been changed.

Table 5-12. Pin Description of Smart Card Reader Interface Signals

Pin(s) No.	Symbol	Attribute	Power	Description
31	SCRRST/ MSBS_S/ GP14	DOD8/ DO8/ DIOD8	VCC	Smart Card Reset / MS I/F Bus State (Secondary) / General Purpose I/O 13. <ul style="list-style-type: none"> The first function of this pin is Smart Card Reset. The second function of this pin is MS I/F Bus State. This is the secondary port. The third function of this pin is the General Purpose I/O Port 1 Bit 4. The function configuration of this pin is determined by programming the software configuration registers.
32	SCRPFET#/ MSIO_S/ GP13	DOD8/ DIO8/ DIOD8	VCC	Smart Card Power FET Control Output # / MS I/F Data I/O (Secondary) / General Purpose I/O 13. <ul style="list-style-type: none"> The first function of this pin is Smart Card Power FET Control Output #. The Smart Card Reader interface requires this pin to drive an external Power FET to supply the current for the Smart Card. The second function of this pin is MS I/F Data I/O. This is the secondary port. The third function of this pin is the General Purpose I/O Port 1 Bit 3. The function configuration of this pin is determined by programming the software configuration registers.
33	SCRIO/ MSPWR_S/ GP12	DIOD8/ DOD8/ DIOD8	VCC	Smart Card Serial Data I/O / MS I/F Power FET Control (Secondary) / General Purpose I/O 12. <ul style="list-style-type: none"> The first function of this pin is Smart Card Serial Data I/O. The second function of this pin is MS I/F Power FET Control. This is the secondary port. The third function of this pin is the General Purpose I/O Port 1 Bit 2. The function configuration of this pin is determined by programming the software configuration registers.
34	SCRCLK/ MSCLK_S/ GP11	DOD8/ DO8/ DIOD8	VCC	Smart Card Clock / MS I/F Clock (Secondary) / General Purpose I/O 11. <ul style="list-style-type: none"> The first function of this pin is Smart Card Clock. Three different card clocks are selectable from this pin: high speed (7.1 MHz), low speed (Default: 3.5 MHz) and a programmable card clock. The second function of this pin is MS I/F Clock. This is the secondary port. The third function of this pin is the General Purpose I/O Port 1 Bit 1. The function configuration of this pin is determined by programming the software configuration registers.

Table 5-12. Pin Description of Smart Card Reader Interface Signals[cont'd]

Pin(s) No.	Symbol	Attribute	Power	Description
84	SCPSNT#/ MSDET_S/ GP10	DI/ DI/ DIOD8	VCCH	Smart Card Present Detect # / MS I/F Insertion Detect (Secondary) / General Purpose I/O 10. <ul style="list-style-type: none"> • The first function of this pin is Smart Card Present Detect #. This pin provides the Smart Card insertion detection for the Smart Card Reader interface. Upon detecting the insertion of the Smart Card, this pin will trigger the power-on event. • The second function of this pin is MS I/F Insertion Detect. This is the secondary port. • The third function of this pin is the General Purpose I/O Port 1 Bit 0. • The function configuration of this pin is determined by programming the software configuration registers.

Table 5-13. Pin Description of Memory Stick/Secure Digital Interface Signals

Pin(s) No.	Symbol	Attribute	Power	Description
13	MSPWR/ SDAPWR/ GP35	DOD8/ DOD8/ DIOD8	VCC	MS I/F Power FET Control / SD I/F A Power FET Control / General Purpose I/O 13. <ul style="list-style-type: none"> The first function of this pin is MS I/F Power FET Control. This is the first port. The second function of this pin is SD I/F A Power FET Control. The third function of this pin is the General Purpose I/O Port 3 Bit 5. The function configuration of this pin is determined by programming the software configuration registers.
14	SDA_D3/ GP34	DIO8/ DIOD8	VCC	SD I/F A Data 3 / General Purpose I/O 34. <ul style="list-style-type: none"> The first function of this pin is SD I/F A Data 3. The second function of this pin is the General Purpose I/O Port 3 Bit 4. The function configuration of this pin is determined by programming the software configuration registers.
16	MSBS/ SDACMD/ GP33	DO8/ DIO8/ DIOD8	VCC	MS I/F Bus State / SD I/F A Command / General Purpose I/O 33. <ul style="list-style-type: none"> The first function of this pin is MS I/F Bus State. This is the first port. The second function of this pin is SD I/F A Command. The third function of this pin is the General Purpose I/O Port 3 Bit 3. The function configuration of this pin is determined by programming the software configuration registers.
17	MSDET/ SDA_D2/ GP32	DI/ DIO8/ DIOD8	VCC	MS I/F Insertion Detect / SD I/F A Data 2 / General Purpose I/O 32. <ul style="list-style-type: none"> The first function of this pin is MS I/F Insertion Detect. This is the first port. The second function of this pin is SD I/F A Data 2. The third function of this pin is the General Purpose I/O Port 3 Bit 2. The function configuration of this pin is determined by programming the software configuration registers.

Table 5-13. Pin Description of Memory Stick/Secure Digital Interface Signals[cont'd]

Pin(s) No.	Symbol	Attribute	Power	Description
18	MSLED/ SDALED/ GP31	DOD8/ DOD8/ DIOD8	VCC	MS I/F LED / SD I/F A LED / General Purpose I/O 31. <ul style="list-style-type: none"> The first function of this pin is MS I/F LED. This is the first port. The second function of this pin is SD I/F A LED. The third function of this pin is the General Purpose I/O Port 3 Bit 1. The function configuration of this pin is determined by programming the software configuration registers.
19	MSIO/ SDA_D0/ GP30	DIO8/ DIO8/ DIOD8	VCC	MS I/F Data I/O / SD I/F A Data 0 / General Purpose I/O 30. <ul style="list-style-type: none"> The first function of this pin is MS I/F Data I/O. This is the first port. The second function of this pin is SD I/F A Data 0. The third function of this pin is the General Purpose I/O Port 3 Bit 0. The function configuration of this pin is determined by programming the software configuration registers.
36	MSCLK/ SDACLK	DO8/ DO8	VCC	MS I/F Clock / SD I/F A Clock. <ul style="list-style-type: none"> The first function of this pin is MS I/F Clock. This is the first port. The second function of this pin is SD I/F A Clock. The function configuration of this pin is determined by programming the software configuration registers.
48	SDA_D1/ GP50	DIO8/ DIOD8	VCC	SD I/F A Data 1 / General Purpose I/O 50. <ul style="list-style-type: none"> The first function of this pin is SD I/F A Data 1. The second function of this pin is the General Purpose I/O Port 5 Bit 0. The function configuration of this pin is determined by programming the software configuration registers.
78	MSLED_S/ GP41	DOD8/ DIOD8	VCCH	MS I/F LED (Secondary) / General Purpose I/O 41. <ul style="list-style-type: none"> The first function of this pin is MS I/F LED. This is the secondary port. The second function of this pin is the General Purpose I/O Port 4 Bit 1. The function configuration of this pin is determined by programming the software configuration registers.

Table 5-14. Pin Description of Memory Stick/Secure Digital Interface Signals

Pin(s) No.	Symbol	Attribute	Power	Description
80	KDAT	DIOD16	VCCH	Keyboard Data.
81	KCLK	DIOD16	VCCH	Keyboard Clock.
82	MDAT	DIOD16	VCCH	PS/2 Mouse Data.
83	MCLK	DIOD16	VCCH	PS/2 Mouse Clock.
45	GA20	DO16	VCC	Gate Address 20.
46	GA20	DO16	VCC	Gate Address 20.

Table 5-15. Pin Description of Miscellaneous Signals

Pin(s) No.	Symbol	Attribute	Power	Description
49	CLKIN	DI	VCC	24 or 48 MHz Clock Input.
72	PWRON#/ GP44	DOD8/ DIOD8	VCCH	Power On Request Output # / General Purpose I/O 34. <ul style="list-style-type: none"> The first function of this pin is Power On Request Output #. The second function of this pin is the General Purpose I/O Port 4 Bit 4. The function configuration of this pin is determined by programming the software configuration registers.
75	PANSWH#/ GP43	DI/ DIOD8	VCCH	Main Power Switch Button Input # / General Purpose I/O 43. <ul style="list-style-type: none"> The first function of this pin is Main Power Switch Button Input #. The second function of this pin is the General Purpose I/O Port 4 Bit 3. The function configuration of this pin is determined by programming the software configuration registers.
76	PSON#/ GP42	DOD8/ DIOD8	VCCH	Power Supply On-Off Output # / General Purpose I/O 42. <ul style="list-style-type: none"> The first function of this pin is Power Supply On-Off Control Output #. The second function of this pin is the General Purpose I/O Port 4 Bit 2. The function configuration of this pin is determined by programming the software configuration registers.
71	PSIN#/ GP45	DI/ DIOD8	VCCH	Power Supply On-Off Switch Input # / General Purpose I/O 45. <ul style="list-style-type: none"> The first function of this pin is Power Supply On-Off Switch Input #. The second function of this pin is the General Purpose I/O Port 4 Bit 5. The function configuration of this pin is determined by programming the software configuration registers.
77	RING#/ GP53	DI/ DIOD8	VCCH	Ring Wake Up Input # / General Purpose I/O 53. <ul style="list-style-type: none"> The first function of this pin is Ring Wake Up Input #. The second function of this pin is the General Purpose I/O Port 5 Bit 3. The function configuration of this pin is determined by programming the software configuration registers.
79	GP40	DIOD8	VCCH	General Purpose I/O 45. <ul style="list-style-type: none"> The first function of this pin is reserved. The second function of this pin is the General Purpose I/O Port 4 Bit 5. The function configuration of this pin is determined by programming the software configuration registers.

Note 1: In addition to providing a highly integrated chip, ITE has also implemented a “SmartGuardian Utility” for hardware monitor application, providing a total solution for customers. The “SmartGuardian Utility” and the application circuit of the hardware monitor function (the function arrangement of VIN0-7, TMPIN1-3, FAN_TAC1-3 and FAN_CTL1-3) are interdependent. That is to say, the “SmartGuardian Utility” is programmed according to the application circuit of the hardware monitor function. ITE strongly recommends customers to follow the referenced application circuit of IT8722F to reduce the “time-to-market” schedule.

Pin No.	Symbol	Recommended function arrangement
98	VIN0	2 Volt for VCORE1 of CPU
97	VIN1	2 Volt for VCORE2 of CPU
96	VIN2	3.3 Volt for system
95	VIN3	5 Volt for system
94	VIN4	+12 Volt for system
93	VIN5	-12 Volt for system
92	VIN6	-5 Volt for system
91	VIN7	5 Volt for VCCH

IO Cell:

DO8: 8mA Digital Output buffer

DOD8: 8mA Digital Open-Drain Output buffer

DO16: 16mA Digital Output buffer

DO24: 24mA Digital Output buffer

DO40: 48mA Digital Output buffer

DIO8: 8mA Digital input/output buffer

DIOD8: 8mA Digital Open-Drain input/output buffer

DIO16: 16mA Digital input/output buffer

DIOD16: 16mA Digital Open-Drain input/output buffer

DIO24: 24mA Digital input/output buffer

DI: Digital Input

AI: Analog Input

AO: Analog Output

6. List of GPIO Pins

Table 6-1. General Purpose I/O Group 1 (Set 1)

Pin(s) No.	Symbol	Attribute	Description
84	SCPSNT#/MSD ET_S/GP10	DI/DI/ DIOD8	<i>Smart Card Present Detect # / MS I/F Insertion Detect (Secondary) / General Purpose I/O 10.</i>
34	SCRCLK/MSC LK_SGP11	DOD8/DO8/ DIOD8	<i>Smart Card Clock / MS I/F Clock (Secondary) / General Purpose I/O 11.</i>
33	SCRIO/MSPW R_S/GP12	DIOD8/ DOD8/ DIOD8	<i>Smart Card Serial Data I/O / MS I/F Power FET Control (Secondary) / General Purpose I/O 12.</i>
32	SCRPFET#/ MSIO_S/GP13	DOD8/DIO/ DIOD8	<i>Smart Card Power FET Control Output # / MS I/F Data I/O (Secondary) / General Purpose I/O 13.</i>
31	SCRRST/ MSBS_S/GP14	DOD8/DO8/ DIOD8	<i>Smart Card Reset / MS I/F Bus State (Secondary) / General Purpose I/O 14.</i>
30	CIRTX/GP15	DOD8/ DIOD8	<i>Consumer Infrared Transmit Output / General Purpose I/O 15.</i>
29	MIDI_IN/GP16	DI/DIOD8	<i>MIDI Input / General Purpose I/O 16.</i>
28	MIDI_OUT/ GP17	DO8/DIOD8	<i>MIDI Output / General Purpose I/O 17.</i>

Table 6-2. General Purpose I/O Group 2 (Set 2)

Pin(s) No.	Symbol	Attribute	Description
27	JSACX/GP20	DIOD8/ DIOD8	<i>Joystick A Coordinate X / General Purpose I/O 20.</i>
26	JSACY/GP21	DIOD8/ DIOD8	<i>Joystick A Coordinate Y / General Purpose I/O 21.</i>
25	JSAB1/GP22	DI/DIOD8	<i>Joystick A Button 1 / General Purpose I/O 22.</i>
24	JSAB2/GP23	DI/DIOD8	<i>Joystick A Button 2 / General Purpose I/O 23.</i>
23	JSBCX/GP24	DIOD8/ DIOD8	<i>Joystick B Coordinate X / General Purpose I/O 24.</i>
22	JSBCY/GP25	DIOD8/ DIOD8	<i>Joystick B Coordinate Y / General Purpose I/O 25.</i>
21	JSBB1/GP26	DI/DIOD8	<i>Joystick B Button 1 / General Purpose I/O 26.</i>
20	JSBB2/GP27	DI/DIOD8	<i>Joystick B Button 2 / General Purpose I/O 27.</i>

Table 6-3. General Purpose I/O Group 3 (Set 3)

Pin(s) No.	Symbol	Attribute	Description
19	MSIO/SDA_D0/ GP30	DIO8/DIO8/ DIOD8	MS I/F Data I/O / SD I/F A Data 0 / General Purpose I/O 30.
18	MSLED/ SDALED/GP31	DOD8/ DOD8/ DI/DIOD8	MS I/F LED / SD I/F A LED / General Purpose I/O 31.
17	MSDET/SDA_D 2/GP32	DI/DIO8/ DIOD8	MS I/F Insertion Detect / SD I/F A Data 2 / General Purpose I/O 32.
16	MSBS/SDACMD / GP33	DO8/DIO8/ DIOD8	MS I/F Bus State / SD I/F A Command / General Purpose I/O 33.
14	SDA_D3/ GP34	DIO8/ DIOD8	SD I/F A Data 3 / General Purpose I/O 34.
13	MSPWR/ SDAPWR/GP35	DOD8/ DOD8/ DIOD8	MS I/F Power FET Control / SD I/F A Power FET Control / General Purpose I/O 35.
12	FAN_CTL3/ GP36	DOD8/ DIOD8	Fan Control Output 3 / General Purpose I/O 36.
11	FAN_TAC3/ GP37	DI/DIOD8	Fan Tachometer Input 3 / General Purpose I/O 37.

Table 6-4. General Purpose I/O Group 4 (Set 4)

Pin(s) No.	Symbol	Attribute	Description
79	GP40	DIOD8	General Purpose I/O 40. /
78	MSDET_S/ GP41	DI/DIOD8	Memory Stick Insertion Detection (Secondary) / General Purpose I/O 41.
76	PSON#/GP42	DOD8/ DIOD8	Power Supply On-Off Control Output # / General Purpose I/O 42.
75	PANSWH#/GP 43	DI/DIOD8	Main Power Switch Button Input # / General Purpose I/O 43.
72	PWRON#/GP4 4	DOD8/ DIOD8	Power On Request Output # / General Purpose I/O 44.
71	PSIN/GP45	DI/DIOD8	Power Supply On-Off Switch Input / General Purpose I/O 45.
70	IRRX/GP46	DI/DIOD8	Infrared Receive Input / General Purpose I/O 46.
66	IRTX/GP47	DO8/DIOD8	Infrared Transmit Output / General Purpose I/O 47.

Table 6-5. General Purpose I/O Group 5 (Set 5)

Pin(s) No.	Symbol	Attribute	Description
48	SDA_D1/GP50	DIO16/ DIOD16	SD I/F A Data 1 / General Purpose I/O 50.
10	FAN_CTL2/GP 51	DOD8/ DIOD8	Fan Control Output 2 / General Purpose I/O 51.
9	FAN_TAC2/GP 52	DI/DIOD8	Fan Tachometer Input 2 / General Purpose I/O 52.
77	RING#/GP53	DI/DIOD8	Ring Wake Up Input # / General Purpose I/O 53
73	PME#/GP54	DOD8/ DIOD8	Power Management Event # / General Purpose I/O 54.
85	CIRRX/COPEN O# /GP55	DI/DOD8/ DIOD8	Consumer Infrared Receive Input / Case Open Output # / General Purpose I/O 55.

7. Power On Strapping Options and Special Pin Routings

Table 7-1. Power On Strapping Options

	Symbol	Value	Description
JP1	KBCEN	1	KBC is enabled.
		0	KBC is disabled.
JP2	KBC_IROM	1	KBC's ROM is built in.
		0	KBC's ROM is external. This is used for custom code verification. A special application circuit is required.
JP3	CHIP_ID	-	Chip ID. Please refer to 9.3.5 for detail.

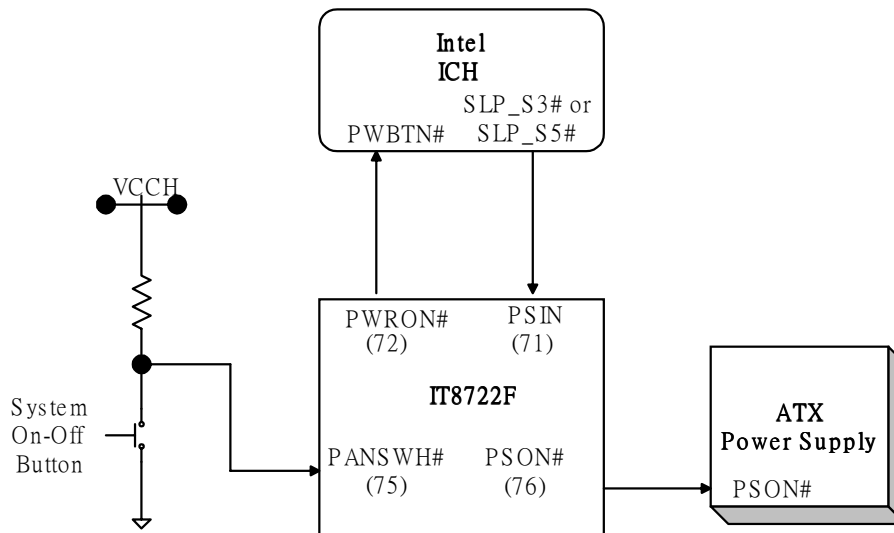
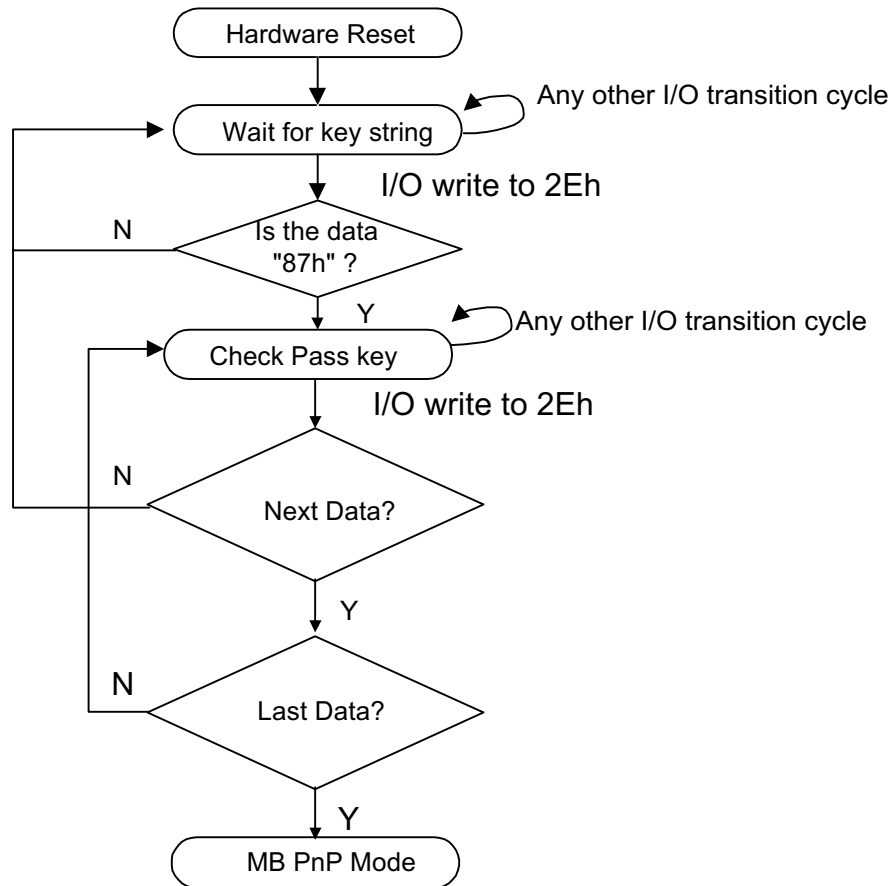

Figure 7-1. IT8722F Special Applications Circuitry for Intel ICH

8. Configuration

8.1 Configuring Sequence Description

After the hardware reset or power-on reset, the IT8722F enters the normal mode with all logical devices disabled except KBC. The initial state (enable bit) of this logical device (KBC) is determined by the state of pin 121 (DTR1#) at the falling edge of the system reset during power-on reset.



There are three steps to complete the configuration setup: (1) Enter the MB PnP Mode; (2) Modify the data of configuration registers; (3) Exit the MB PnP Mode. Undesired result may occur if the MB PnP Mode is not exited normally.

(1) Enter the MB PnP Mode

To enter the MB PnP Mode, four special I/O write operations are to be performed during Wait for Key state. To ensure the initial state of the key-check logic, it is necessary to perform four write operations to the Special Address port (2Eh). Two different enter keys are provided to select configuration ports (2Eh/2Fh or 4Eh/4Fh) of the next step.

	<u>Address port</u>	<u>Data port</u>
87h, 01h, 55h, 55h;	2Eh	2Fh
or 87h, 01h, 55h, AAh;	4Eh	4Fh

(2) Modify the Data of the Registers

All configuration registers can be accessed after entering the MB PnP Mode. Before accessing a selected register, the content of Index 07h must be changed to the LDN to which the register belongs, except some Global registers.

(3) Exit the MB PnP Mode

Set bit 1 of Configure Control register (Index=02h) to “1” to exit the MB PnP Mode.

8.2 Description of the Configuration Registers

All the registers except APC/PME’ registers will be reset to the default state when RESET is activated.

Table 8-1. Global Configuration Registers

LDN	Index	R/W	Reset	Configuration Register or Action
All	02h	W	NA	Configure Control
All	07h	R/W	NA	Logical Device Number (LDN)
All	20h	R	87h	Chip ID Byte 1
All	21h	R	22h	Chip ID Byte 2
All	22h	R	00h	Chip Version
All	23h	R/W	00h	Clock Selection Register
All	24h	R/W	00h	Software Suspend
07h	25h	R/W	00h	GPIO Set 1 Multi-Function Pin Selection Register
07h	26h	R/W	00h	GPIO Set 2 Multi-Function Pin Selection Register
07h	27h	R/W	00h	GPIO Set 3 Multi-Function Pin Selection Register
07h	28h	R/W	00h	GPIO Set 4 Multi-Function Pin Selection Register
07h	29h	R/W	00h	GPIO Set 5 Multi-Function Pin Selection Register
F4h ^{Note1}	2Eh	R/W	00h	Test 1 Register
F4h ^{Note1}	2Fh	R/W	00h	Test 2 Register

Table 8-2. FDC Configuration Registers

LDN	Index	R/W	Reset	Configuration Register or Action
00h	30h	R/W	00h	FDC Activate
00h	60h	R/W	03h	FDC Base Address MSB Register
00h	61h	R/W	F0h	FDC Base Address LSB Register
00h	70h	R/W	06h	FDC Interrupt Level Select
00h	74h	R/W	02h	FDC DMA Channel Select
00h	F0h	R/W	00h	FDC Special Configuration Register 1
00h	F1h	R/W	00h	FDC Special Configuration Register 2

Table 8-3. Serial Port 1 Configuration Registers

LDN	Index	R/W	Reset	Configuration Register or Action
01h	30h	R/W	00h	Serial Port 1 Activate
01h	60h	R/W	03h	Serial Port 1 Base Address MSB Register
01h	61h	R/W	F8h	Serial Port 1 Base Address LSB Register
01h	70h	R/W	04h	Serial Port 1 Interrupt Level Select
01h	F0h	R/W	00h	Serial Port 1 Special Configuration Register 1
01h	F1h	R/W	50h	Serial Port 1 Special Configuration Register 2
01h	F2h	R/W	00h	Serial Port 1 Special Configuration Register 3
01h	F3h	R/W	7Fh	Serial Port 1 Special Configuration Register 4

Table 8-4. Serial Port 2 Configuration Registers

LDN	Index	R/W	Reset	Configuration Register or Action
02h	30h	R/W	00h	Serial Port 2 Activate
02h	60h	R/W	02h	Serial Port 2 Base Address MSB Register
02h	61h	R/W	F8h	Serial Port 2 Base Address LSB Register
02h	70h	R/W	03h	Serial Port 2 Interrupt Level Select
02h	F0h	R/W	00h	Serial Port 2 Special Configuration Register 1
02h	F1h	R/W	50h	Serial Port 2 Special Configuration Register 2
02h	F2h	R/W	00h	Serial Port 2 Special Configuration Register 3
02h	F3h	R/W	7Fh	Serial Port 2 Special Configuration Register 4

Table 8-5. Parallel Port Configuration Registers

LDN	Index	R/W	Reset	Configuration Register or Action
03h	30h	R/W	00h	Parallel Port Activate
03h	60h	R/W	03h	Parallel Port Primary Base Address MSB Register
03h	61h	R/W	78h	Parallel Port Primary Base Address LSB Register
03h	62h	R/W	07h	Parallel Port Secondary Base Address MSB Register
03h	63h	R/W	78h	Parallel Port Secondary Base Address LSB Register
03h	70h	R/W	07h	Parallel Port Interrupt Level Select
03h	74h	R/W	03h	Parallel Port DMA Channel Select ^{Note2}
03h	F0h	R/W	03h ^{Note3}	Parallel Port Special Configuration Register

Table 8-6. Environment Controller Configuration Registers

LDN	Index	R/W	Reset	Configuration Register or Action
04h	30h	R/W	00h	Environment Controller Activate
04h	60h	R/W	02h	Environment Controller Base Address MSB Register
04h	61h	R/W	90h	Environment Controller Base Address LSB Register
04h	62h	R/W	02h	PME Direct Access Base Address MSB Register
04h	63h	R/W	30h	PME Direct Access Base Address LSB Register
04h	70h	R/W	09h	Environment Controller Interrupt Level Select
04h	F0h	R/W	00h	APC/PME Event Enable Register
04h	F1h	R/W	00h	APC/PME Status Register
04h	F2h	R/W	00h	APC/PME Control Register 1
04h	F3h	R/W	00h	Environment Controller Special Configuration Register
04h	F4h	R-R/W	00h	APC/PME Control Register 2
04h	F5h	R/W	-	APC/PME Special Code Index Register
04h	F6h	R/W	-	APC/PME Special Code Data Register

Table 8-7. KBC(Keyboard) Configuration Registers

LDN	Index	R/W	Reset	Configuration Register or Action
05h	30h	R/W	Note4	KBC Activate
05h	60h	R/W	00h	KBC Data Base Address MSB Register
05h	61h	R/W	60h	KBC Data Base Address LSB Register
05h	62h	R/W	00h	KBC Command Base Address MSB Register
05h	63h	R/W	64h	KBC Command Base Address LSB Register
05h	70h	R/W	01h	KBC Interrupt Level Select
05h	71h	R-R/W	02h	KBC Interrupt Type ^{Note5}
05h	F0h	R/W	00h	KBC Special Configuration Register

Table 8-8. KBC(Mouse) Configuration Registers

LDN	Index	R/W	Reset	Configuration Register or Action
06h	30h	R/W	00h	KBC (Mouse) Activate
06h	70h	R/W	0Ch	KBC (Mouse) Interrupt Level Select
06h	71h	R-R/W	02h	KBC (Mouse) Interrupt Type ^{Note5}
06h	F0h	R/W	00h	KBC (Mouse) Special Configuration Register

Table 8-9. GPIO Configuration

LDN	Index	R/W	Reset	Configuration Register or Action
07h	60h	R/W	00h	SMI# Normal Run Access Base Address MSB Register
07h	61h	R/W	00h	SMI# Normal Run Access Base Address LSB Register
07h	62h	R/W	00h	Simple I/O Base Address MSB Register
07h	63h	R/W	00h	Simple I/O Base Address LSB Register
07h	64h	R/W	00h	Panel Button De-bounce Base Address MSB Register
07h	65h	R/W	00h	Panel Button De-bounce Base Address LSB Register
07h	70h	R/W	00h	Panel Button De-bounce Interrupt Level Select Register
07h	71h	R/W	00h	Watch Dog Timer Control Register
07h	72h	R/W	00h	Watch Dog Timer Configuration Register
07h	73h	R/W	00h	Watch Dog Timer Time-out Value Register
07h	B0h	R/W	00h	GPIO Set 1 Pin Polarity Register
07h	B1h	R/W	00h	GPIO Set 2 Pin Polarity Register
07h	B2h	R/W	00h	GPIO Set 3 Pin Polarity Register
07h	B3h	R/W	00h	GPIO Set 4 Pin Polarity Register
07h	B4h	R/W	00h	GPIO Set 5 Pin Polarity Register
07h	B8h	R/W	00h	GPIO Set 1 Pin Internal Pull-up Enable Register
07h	B9h	R/W	00h	GPIO Set 2 Pin Internal Pull-up Enable Register
07h	BAh	R/W	00h	GPIO Set 3 Pin Internal Pull-up Enable Register
07h	BBh	R/W	00h	GPIO Set 4 Pin Internal Pull-up Enable Register
07h	BCh	R/W	00h	GPIO Set 5 Pin Internal Pull-up Enable Register
07h	C0h	R/W	00h	Simple I/O Set 1 Enable Register
07h	C1h	R/W	00h	Simple I/O Set 2 Enable Register
07h	C2h	R/W	00h	Simple I/O Set 3 Enable Register

Table 8-10. GPIO Configuration Registers

LDN	Index	R/W	Reset	Configuration Register or Action
07h	C3h	R/W	00h	Simple I/O Set 4 Enable Register
07h	C4h	R/W	00h	Simple I/O Set 5 Enable Register
07h	C8h	R/W	00h	Simple I/O Set 1 Output Enable Register
07h	C9h	R/W	00h	Simple I/O Set 2 Output Enable Register
07h	CAh	R/W	00h	Simple I/O Set 3 Output Enable Register
07h	CBh	R/W	00h	Simple I/O Set 4 Output Enable Register
07h	CCh	R/W	00h	Simple I/O Set 5 Output Enable Register
07h	D0h	R/W	00h	Panel Button De-bounce Control Register
07h	D1h	R/W	00h	Panel Button De-bounce Set 1 Enable Register
07h	D2h	R/W	00h	Panel Button De-bounce Set 2 Enable Register
07h	D3h	R/W	00h	Panel Button De-bounce Set 3 Enable Register
07h	D4h	R/W	00h	Panel Button De-bounce Set 4 Enable Register
07h	D5h	R/W	00h	Panel Button De-bounce Set 5 Enable Register
07h	E3h	R/W	00h	IRQ3 External Routing Input Pin Mapping Register
07h	E4h	R/W	00h	IRQ4 External Routing Input Pin Mapping Register
07h	E5h	R/W	00h	IRQ5 External Routing Input Pin Mapping Register
07h	E6h	R/W	00h	IRQ6 External Routing Input Pin Mapping Register
07h	E7h	R/W	00h	IRQ7 External Routing Input Pin Mapping Register
07h	E9h	R/W	00h	IRQ9 External Routing Input Pin Mapping Register
07h	EAh	R/W	00h	IRQ10 External Routing Input Pin Mapping Register
07h	EBh	R/W	00h	IRQ11 External Routing Input Pin Mapping Register
07h	ECh	R/W	00h	IRQ12 External Routing Input Pin Mapping Register
07h	EEh	R/W	00h	IRQ14 External Routing Input Pin Mapping Register
07h	EFh	R/W	00h	IRQ15 External Routing Input Pin Mapping Register
07h	F0h	R/W	00h	SMI# Control Register 1
07h	F1h	R/W	00h	SMI# Control Register 2
07h	F2h	R/W	00h	SMI# Status Register 1
07h	F3h	R/W	00h	SMI# Status Register 2
07h	F4h	R/W	00h	SMI# Pin Mapping Register
07h	F5h	R/W	00h	Hardware Monitor Thermal Output Pin Mapping Register
07h	F6h	R/W	00h	Hardware Monitor Alert Beep Pin Mapping Register
07h	F7h	R/W	00h	Keyboard Lock Pin Mapping Register
07h	F8h	R/W	00h	GP LED Blinking 1 Pin Mapping Register
07h	F9h	R/W	00h	GP LED Blinking 1 Control Register
07h	FAh	R/W	00h	GP LED Blinking 2 Pin Mapping Register
07h	FBh	R/W	00h	GP LED Blinking 2 Control Register

Table 8-11. MIDI Port Configuration Registers

LDN	Index	R/W	Reset	Configuration Register or Action
08h	30h	R/W	00h	MIDI Port Activate
08h	60h	R/W	03h	MIDI Port Base Address MSB Register
08h	61h	R/W	00h	MIDI Port Base Address LSB Register
08h	70h	R/W	0Ah	MIDI Port Interrupt Level Select
08h	F0h	R/W	00h	MIDI Port Special Configuration Register

Table 8-12. Game Port Configuration Registers

LDN	Index	R/W	Reset	Configuration Register or Action
09h	30h	R/W	00h	Game Port Activate
09h	60h	R/W	02h	Game Port Base Address MSB Register
09h	61h	R/W	01h	Game Port Base Address LSB Register

Table 8-13. Consumer IR Configuration Registers

LDN	Index	R/W	Reset	Configuration Register or Action
0Ah	30h	R/W	00h	Consumer IR Activate
0Ah	60h	R/W	03h	Consumer IR Base Address MSB Register
0Ah	61h	R/W	10h	Consumer IR Base Address LSB Register
0Ah	70h	R/W	0Bh	Consumer IR Interrupt Level Select
0Ah	F0h	R/W	00h	Consumer IR Special Configuration Register

Table 8-14. Memory Stick Configuration Registers

LDN	Index	R/W	Reset	Configuration Register or Action
0Bh	30h	R/W	00h	Memory Stick Activate
0Bh	60h	R/W	02h	Memory Stick Base Address MSB Register
0Bh	61h	R/W	20h	Memory Stick Base Address LSB Register
0Bh	70h	R/W	05h	Memory Stick Interrupt Level Select
0Bh	74h	R/W	05h	Memory Stick DMA Channel Select
0Bh	F0h	R/W	00h	Memory Stick Special Configuration Register

Table 8-15. SD Configuration Registers

LDN	Index	R/W	Reset	Configuration Register or Action
0Ch	30h	R/W	00h	SD Activate
0Ch	60h	R/W	02h	SD Base Address MSB Register
0Ch	61h	R/W	30h	SD Base Address LSB Register
0Ch	70h	R/W	09h	SD Interrupt Level Select
0Ch	74h	R/W	06h	SD DMA Channel Select
0Ch	F0h	R/W	00h	SD Special Configuration Register

Note 1: All these registers can be read from all LDNs.

Note 2: When the ECP mode is not enabled, this register is **read only** as “04h”, and cannot be written.

Note 3: When the bit 2 of the Primary Base Address LSB Register of Parallel Port is set to 1, the EPP mode cannot be enabled. Bit 0 of this register is always 0.

Note 4: The initial value of the activate bit of KBC is determined by the latched state of DTR1# at the rising edge of the LRESET# signal.

Note 5: These registers are **read only** unless the write enable bit (Index=F0h) is asserted.

8.2.1 Logical Device Base Address

The base I/O range of logical devices shown below is located in the base I/O address range of each logical device.

Table 8-16. Base Address of Logical Devices

Logical Devices	Address	Notes
LDN=0 FDC	Base + (2 - 5) and + 7	
LDN=1 SERIAL PORT 1	Base + (0 -7)	
LDN=2 SERIAL PORT 2	Base1 + (0 -7)	COM port
LDN=3 PARALLEL PORT	Base1 + (0 -3)	SPP
	Base1 + (0 -7)	SPP+EPP
	Base1 + (0 -3) and Base2 + (0 -3)	SPP+ECP
	Base1 + (0 -7) and Base2 + (0 -3)	SPP+EPP+ECP
Base3	POST data port	
LDN=4 Environment Controller	Base1 + (0 -7)	Environment Controller
	Base2 + (0 -3)	PME#
LDN=5 KBC	Base1 + Base2	KBC
LDN=8 MIDI port	Base + (0 -1)	
LDN=9 Game Port	Base	
LDN=A Consumer IR	Base + (0 -7)	
LDN=B Memory Stick Controller	Base + (0 -7)	
LDN=C Secure Digital Controller	Base + (0 -1)	

8.3 Global Configuration Registers (LDN: All)

8.3.1 Configure Control (Index=02h)

This register is **write only**. Its values are not sticky; that is to say, a hardware reset will automatically clear the bits and does not require the software to clear them.

Bit	Description
7-2	Reserved
1	Returns to the “Wait for Key” state. This bit is used when the configuration sequence is completed.
0	Resets all logical devices and restores configuration registers to their power-on states.

8.3.2 Logical Device Number (LDN, Index=07h)

This register is used to select the current logical devices. By reading from or writing to the configuration of I/O, Interrupt, DMA and other special functions, all registers of the logical devices can be accessed. In addition, ACTIVATE command is only effective for the selected logical devices. This register is **read/write**.

8.3.3 Chip ID Byte 1 (Index=20h, Default=87h)

This register is the Chip ID Byte 1 and is **read only**. Bits [7:0]=87h when read.

8.3.4 Chip ID Byte 2 (Index=21h, Default=22h)

This register is the Chip ID Byte 2 and is **read only**. Bits [7:0]=22h when read.

8.3.5 Chip Version (Index=22h, Default=00h)

This register is the Chip Version and is **read only**.

8.3.6 Clock Selection Register (Index=23h, Default=00h)

Bit	Description
7-2	Reserved
1	SD_Clock_Sel Select the clock source for SD I/F controller. 1: 33MHz -- PCICLK. 0: 48MHz -- CLKIN.
0	CLKIN Frequency 0: 48 MHz. 1: 24 MHz.

8.3.7 Software Suspend (Index=24h, Default=00h, MB PnP)

This register is the Software Suspend register. When bit 0 is set, the IT8722F enters the “Software Suspend” state. All the devices, except KBC, remain inactive until this bit is cleared or when the wake-up event occurs. The wake-up event occurs at any transition on signals RI1# (pin 119) and RI2# (pin 127).

8.3.8 GPIO Set 1 Multi-Function Pin Selection Register (Index=25h, Default=00h)

If the enabled bits are not set, the multi-function pins will perform the original functions. On the contrary, if they are set, they will perform the GPIO functions. This register can be read from any LDN, but can only be written if LDN=07h.

Bit	Description
7	Perform the Function Selection of MIDI_OUT or GP17 of Pin 28 0: Selects the function of MIDI Output (MIDI_OUT). 1: Selects the function of General Purpose I/O 17 (GP17).
6	Perform the Function Selection of MIDI_IN or GP16 of pin 29 0: Selects the function of MIDI Input (MIDI_IN). 1: Selects the function of General Purpose I/O 16 (GP16).
5	Perform the Function Selection of CIRTX or GP15 of 30 0: Selects the function of Consumer Infrared Transmit Output (CIRTX). 1: Selects the function of General Purpose I/O 15 (GP15).
4	Perform the Function Selection of SCRRST, MSBS_S, or GP14 of pin 31 0: Selects the function of Smart Card Reset (SCRRST) or MSBS_S (if bit 1 of Memory Stick Special configuration register is set to 1). 1: Selects the function of General Purpose I/O 14 (GP14).
3	Perform the Function Selection of SCRFET#, MSIO_S, or GP13 of pin 32 0: Selects the function of Smart Card Power FET Control Output #. 1: Selects the function of General Purpose I/O 13 (GP13) or MSIO_S (if bit 1 of Memory Stick Special configuration register is set to 1).
2	Perform the Function Selection of SCRIO, MSPWR_S, or GP12 of pin 33 0: Selects the function of Smart Card Serial Data I/O (SCRIO). 1: Selects the function of General Purpose I/O 12 (GP12) or MSPWR_S (if bit 1 of Memory Stick Special configuration register is set to 1).
1	Perform the Function Selection of SCRCLK, MSCLK_S, or GP11 of pin 34 0: Selects the function of Smart Card Clock (SCRCLK). 1: Selects the function of General Purpose I/O 11 (GP11) or MSCLK_S (if bit 1 of Memory Stick Special configuration register is set to 1).
0	Perform the Function Selection of SCRPRES#, MSDET_S, or GP10 of pin 84 0: Selects the function of Smart Card Present Detect# (SCRPRES#). 1: Selects the function of General Purpose I/O 10 (GP10) or MSDET_S (if bit 1 of Memory Stick Special configuration register is set to 1).

8.3.9 GPIO Set 2 Multi-Function Pin Selection Register (Index=26h, Default=00h)

If the enabled bits are not set, the multi-function pins will perform the original functions. On the contrary, if they are set, they will perform the GPIO functions. This register can be read from any LDN, but can only be written if LDN=07h.

Bit	Description
7	Perform the Function Selection of JSBB2 or GP27 of pin 20 0: Selects the function of Joystick B Button 2 (JSBB2). 1: Selects the function of General Purpose I/O 27 (GP27).
6	Perform the Function Selection of JSBB1 or GP26 of pin 21 0: Selects the function of Joystick B Button 1 (JSBB1). 1: Selects the function of General Purpose I/O 26 (GP26).
5	Perform the Function Selection of JSBCY or GP25 of pin 22 0: Selects the function of Joystick B Coordinate Y (JSBCY). 1: Selects the function of General Purpose I/O 25 (GP25).
4	Perform the Function Selection of JSBCX or GP24 of pin 23 0: Selects the function of Joystick B Coordinate X (JSBCX). 1: Selects the function of General Purpose I/O 24 (GP24).
3	Perform the Function Selection of JSAB2 or GP23 of pin 24 0: Selects the function of Joystick A Button 2 (JSAB2). 1: Selects the function of General Purpose I/O 23 (GP23).
2	Perform the Function Selection of JSAB1 or GP22 of pin 25 0: Selects the function of Joystick A Button 1 (JSAB1). 1: Selects the function of General Purpose I/O 22 (GP22).
1	Perform the Function Selection of JSACY or GP21 pin 26 0: Selects the function of Joystick A Coordinate Y (JSACY). 1: Selects the function of General Purpose I/O 21 (GP21).
0	Perform the Function Selection of JSACX Or GP20 of pin 27 0: Selects the function of Joystick A Coordinate X (JSACX). 1: Selects the function of General Purpose I/O 20 (GP20).

8.3.10 GPIO Set 3 Multi-Function Pin Selection Register (Index=27h, Default=00h)

If the enabled bits are not set, the multi-function pins will perform the original functions. On the contrary, if they are set, they will perform the GPIO functions. This register can be read from any LDN, but can only be written if LDN=07h.

Bit	Description
7	Perform the Function Selection of FAN_TAC3 or GP37 of pin 11 0: Selects the function of Fan Tachometer Input 3 (FAN_TAC3). 1: Selects the function of General Purpose I/O 37 (GP37).
6	Perform the Function Selection of FAN_CTL3 or GP36 of pin 12 0: Selects the function of Fan Control Output 3 (FAN_CTL3). 1: Selects the function of General Purpose I/O 36 (GP36).
5	Perform the Function Selection of MSPWR, SDAPWR, or GP35 of pin 13 0: Selects the function of MSPWR or SDAPWR (if bit 2 of SD Special configuration register is set to 1). 1: Selects the function of General Purpose I/O 35 (GP35).
4	Perform the Function Selection of SDA_D3, or GP34 of pin 14 0: Selects the function of SDA_D3 (if bit 2 of SD Special configuration register is set to 1). 1: Selects the function of General Purpose I/O 34 (GP34).
3	Perform the Function Selection of MSBS, SDACMD, or GP33 of pin 16 0: Selects the function of MSBS or SDACMD (if bit 2 of SD Special configuration register is set to 1). 1: Selects the function of General Purpose I/O 33 (GP33).
2	Perform the Function Selection of MSDET, SDA_D2, or GP32 of pin 17 0: Selects the function of MSDET or SDA_D2 (if bit 2 of SD Special configuration register is set to 1). 1: Selects the function of General Purpose I/O 32 (GP32).
1	Perform the Function Selection of MSLED, SDALED, or GP31 of pin 18 0: Selects the function of MSLED or SDALED (if bit 2 of SD Special configuration register is set to 1). 1: Selects the function of General Purpose I/O 31 (GP31).
0	Perform the Function Selection of MSIO, SDA_D0, or GP30 of pin 19 0: Selects the function of MSIO or SDA_D0 (if bit 2 of SD Special configuration register is set to 1). 1: Selects the function of General Purpose I/O 30 (GP30).

8.3.11 GPIO Set 4 Multi-Function Pin Selection Register (Index=28h, Default=00h)

If the enabled bits are not set, the multi-function pins will perform the original functions. On the contrary, if they are set, they will perform the GPIO functions. This register can be read from any LDN, but can only be written if LDN=07h.

Bit	Description
7	Perform the Function Selection of IRTX or GP47 of pin 66. 0: Selects the function of Infrared Transmit Output (IRTX). 1: Selects the function of General Purpose I/O 47 (GP47).
6	Perform the Function Selection of IRRX or GP46 of pin 70. 0: Selects the function of Infrared Receive Input (IRRX). 1: Selects the function of General Purpose I/O 46 (GP46).
5	Perform the Function Selection of PSIN or GP45 of pin 71. 0: Selects the function of Power Supply On-Off Switch Input (PSIN). 1: Selects the function of General Purpose I/O 45 (GP45).
4	Perform the Function Selection of PWRON# or GP44 of pin 72. 0: Selects the function of Power On Request Output # (PWRON#). 1: Selects the function of General Purpose I/O 44 (GP44).
3	Perform the Function Selection of PANSWH# or GP43 of pin 75. 0: Selects the function of Main Power Switch Button Input # (PANSWH#). 1: Selects the function of General Purpose I/O 43 (GP43).
2	Perform the Function Selection of PSON# or GP42 of pin 76. 0: Selects the function of Power Supply ON-Off Control Output # (PSON#). 1: Selects the function of General Purpose I/O 42 (GP42).
1	Perform the Function Selection of MSLED_S or GP41 of pin 78. 0: Selects the function of MSLED_S (if bit 1 of Memory Stick Special configuration register is set to 1). 1: Selects the function of General Purpose I/O 41 (GP41).
0	Perform the Function Selection of GP40 of pin 79. 0: Reserved. 1: Selects the function of General Purpose I/O 40 (GP40).

8.4 GPIO Set 5 Multi-Function Pin Selection Register (Index=29h, Default=00h)

If the enabled bits are not set, the multi-function pins will perform the original functions. On the contrary, if they are set, they will perform the GPIO functions. This register can be read from any LDN, but can only be written if LDN=07h.

Bit	Description
7	Reserved
6	Reserved
5	Perform the Function Selection of CIRRX or GP55 of pin 85. 0: Selects the function of Consumer Infrared Receive Input (CIRRX). 1: Selects the function of General Purpose I/O 55 (GP55).
4	Perform the Function Selection of PME# or GP54 of pin 73. 0: Selects the function of Power Management Event # (PME#). 1: Selects the function of General Purpose I/O 54 (GP54).
3	Perform the Function Selection of RING# or GP53 of pin 77. 0: Selects the function of Ring Wake Up Input # (RING#). 1: Selects the function of General Purpose I/O 53 (GP53).
2	Perform the Function Selection of FAN_TAC2 or GP52 of pin 9. 0: Selects the function of Fan Tachometer Input 2 (FAN_TAC2). 1: Selects the function of General Purpose I/O 52 (GP52).
1	Perform the Function Selection of FAN_CTL2 or GP51 of pin 10. 0: Selects the function of Fan Control Output 2 (FAN_CTL2). 1: Selects the function of General Purpose I/O 51 (GP51).
0	Perform the Function Selection of SDA_D1, or GP50 of pin 48. 0: Selects the function of SDA_D1 (if bit 2 of SD Special configuration register is set to 1). 1: Selects the function of General Purpose I/O 50 (GP50).

8.4.1 Test 1 Register (Index=2Eh, Default=00h)

This register is the Test 1 Register and is reserved for ITE. It should not be set.

8.4.2 Test 2 Register (Index=2Fh, Default=00h)

This register is the Test 2 Register and is reserved for ITE. It should not be set.

8.5 FDC Configuration Registers (LDN=00h)

8.5.1 FDC Activate (Index=30h, Default=00h)

Bit	Description
7-1	Reserved
0	FDC Enable. 1: Enabled. 0: Disabled.

8.5.2 FDC Base Address MSB Register (Index=60h, Default=03h)

Bit	Description
7-4	Read only , with "0h" for Base Address [15:12].
3-0	Mapped as Base Address [11:8].

8.5.3 FDC Base Address LSB Register (Index=61h, Default=F0h)

Bit	Description
7-3	Read/write , mapped as Base Address [7:3].
2-0	Read only as "000b."

8.5.4 FDC Interrupt Level Select (Index=70h, Default=06h)

Bit	Description
7-4	Reserved with default "0h."
3-0	Select the interrupt level ^{Note1} for FDC.

8.5.5 FDC DMA Channel Select (Index=74h, Default=02h)

Bit	Description
7-3	Reserved with default "00h."
2-0	Select the DMA channel ^{Note2} for FDC. 5h~7h are not available.

8.5.6 FDC Special Configuration Register 1 (Index=F0h, Default=00h)

Bit	Description
7-4	Reserved with default "00h."
3	1: IRQ sharing. 0: Normal IRQ.
2	1: Swap Floppy Drives A, B. 0: Normal.
1	1: 3-mode. 0: AT-mode.
0	1: Software Write Protect. 0: Normal.

8.5.7 FDC Special Configuration Register 2 (Index=F1h, Default=00h)

Bit	Description
7-4	Reserved with default "00h."
3-2	FDD B Data Rate Table Select (DRT1-0).
1-0	FDD A Data Rate Table Select (DRT1-0).

8.6 Serial Port 1 Configuration Registers (LDN=01h)

8.6.1 Serial Port 1 Activate (Index=30h, Default=00h)

Bit	Description
7-1	Reserved
0	Serial Port 1 Enable. 1: Enabled. 0: Disabled.

8.6.2 Serial Port 1 Base Address MSB Register (Index=60h, Default=03h)

Bit	Description
7-4	Read only as "0h" for Base Address [15:12].
3-0	Read/write mapped as Base Address [11:8].

8.6.3 Serial Port 1 Base Address LSB Register (Index=61h, Default=F8h)

Bit	Description
7-3	Read/write, mapped as Base Address [7:3].
2-0	Read only as "000b."

8.6.4 Serial Port 1 Interrupt Level Select (Index=70h, Default=04h)

Bit	Description
7-4	Reserved with default "0h."
3-0	Select the interrupt level ^{Note1} for Serial Port 1.

8.6.5 Serial Port 1 Special Configuration Register 1 (Index=F0h, Default=00h)

Bit	Description
7	Reserved
6-4	Serial Port 1 Mode ^{Note3} 000: Standard (default) 001: IrDA 1.0 (HP SIR) 010: ASKIR 100: Smart Card Reader (SCR) others: Reserved
3	Reserved with default "0."
2-1	Clock Source. 00: 24 MHz/13 (Standard) 01: 24 MHz/12 (MIDI) 10: Reserved 11: Reserved
0	1: IRQ sharing. 0: Normal.

8.6.6 Serial Port 1 Special Configuration Register 2 (Index=F1h, Default=50h)

Bit	Description
7	1: No transmission delay (40 bits) when the SIR or ASKIR is switched from RX mode to TX mode. 0: Transmission delay (40 bits) when the SIR or ASKIR is switched from RX mode to TX mode.
6	1: No reception delay (40 bits) when the SIR or ASKIR is switched from TX mode to RX mode. 0: Reception delay (40 bits) when the SIR or ASKIR is switched from TX mode to RX mode.
5	Single Mask Mode: When set, the RX of UART is masked under TX transmission.
4	1: Half Duplex (default). 0: Full Duplex.
3-0	Reserved

8.6.7 Serial Port 1 Special Configuration Register 3 (Index=F2h, Default=00h)

This register is valid only when Serial Port 1's Mode is Smart Card Reader.

Bit	Description
7-3	Reserved
2	SCRPFET# Polarity
1-0	SCR_CLKSEL1-0 00: Stop 01: 3.5 MHz 10: 7.1 MHz 11: Special Divisor (96 MHz/DIV96M)

8.6.8 Serial Port 1 Special Configuration Register 4 (Index=F3h, Default=7Fh)

This register is valid only when Serial Port 1's Mode is Smart Card Reader.

Bit	Description
7	Reserved
6-0	SCR DIV96M6-0

8.7 Serial Port 2 Configuration Registers (LDN=02h)

8.7.1 Serial Port 2 Activate (Index=30h, Default=00h)

Bit	Description
7-1	Reserved
0	Serial Port 2 Enable. 1: Enabled. 0: Disabled.

8.7.2 Serial Port 2 Base Address MSB Register (Index=60h, Default=02h)

Bit	Description
7-4	Read only with "0h" for Base Address [15:12].
3-0	Read/write , mapped as Base Address [11:8].

8.7.3 Serial Port 2 Base Address LSB Register (Index=61h, Default=F8h)

Bit	Description
7-3	Read/write , mapped as Base Address [7:3].
2-0	Read only as "000b."

8.7.4 Serial Port 2 Interrupt Level Select (Index=70h, Default=03h)

Bit	Description
7-4	Reserved with default "0h."
3-0	Select the interrupt level ^{Note1} for Serial Port 2.

8.7.5 Serial Port 2 Special Configuration Register 1 (Index=F0h, Default=00h)

Bit	Description
7	Reserved
6-4	Serial Port 2 Mode Note3 000: Standard (default) 001: IrDA 1.0 (HP SIR) 010 : ASKIR 100 : Smart Card Reader (SCR) others : Reserved
3	Reserved with default "0."
2-1	Clock Source. 00: 24 MHz/13 (Standard) 01: 24 MHz/12 (MIDI) 10: Reserved 11: Reserved
0	1: IRQ sharing. 0: Normal.

8.7.6 Serial Port 2 Special Configuration Register 2 (Index=F1h, Default=50h)

Bit	Description
7	1: No transmission delay (40 bits) when the SIR or ASKIR is switched from RX mode to TX mode. 0: Transmission delay (40 bits) when the SIR or ASKIR is switched from RX mode to TX mode.
6	1: No reception delay (40 bits) when the SIR or ASKIR is switched from TX mode to RX mode. 0: Reception delay (40 bits) when the SIR or ASKIR is switched from TX mode to RX mode.
5	Single Mask Mode: When set, the RX of UART is masked under TX transmission.
4	1: Half Duplex (default). 0: Full Duplex.
3-0	Reserved

8.7.7 Serial Port 2 Special Configuration Register 3 (Index=F2h, Default=00h)

This register is valid only when Serial Port 2's Mode is Smart Card Reader.

Bit	Description
7-3	Reserved
2	SCRPFET# polarity.
1-0	SCR_CLKSEL1-0. 00: Stop 01: 3.5 MHz 10: 7.1 MHz 11: Special Divisor (96 MHz/DIV96M)

8.7.8 Serial Port 2 Special Configuration Register 4 (Index=F3h, Default=7Fh)

This register is valid only when Serial Port 2's Mode is Smart Card Reader.

Bit	Description
7	Reserved
6-0	SCR DIV96M6-0.

8.8 Parallel Port Configuration Registers (LDN=03h)

8.8.1 Parallel Port Activate (Index=30h, Default=00h)

Bit	Description
7-1	Reserved
0	Parallel Port Enable. 1: Enabled. 0: Disabled.

8.8.2 Parallel Port Primary Base Address MSB Register (Index=60h, Default=03h)

Bit	Description
7-4	Read only as "0h" for Base Address [15:12].
3-0	Read/write, mapped as Base Address [11:8].

8.8.3 Parallel Port Primary Base Address LSB Register (Index=61h, Default=78h)

If bit 2 is set to 1, the EPP mode is disabled automatically.

Bit	Description
7-2	Read/write, mapped as Base Address [7:2].
1-0	Read only as "00b."

8.8.4 Parallel Port Secondary Base Address MSB Register (Index=62h, Default=07h)

Bit	Description
7-4	Read only as "0h" for Base Address [15:12].
3-0	Read/write, mapped as Base Address [11:8].

8.8.5 Parallel Port Secondary Base Address LSB Register (Index=63h, Default=78h)

Bit	Description
7-2	Read/write, mapped as Base Address [7:2].
1-0	Read only as "00b."

8.8.6 Parallel Port Interrupt Level Select (Index =70h, Default=07h)

Bit	Description
7-4	Reserved with default "0h."
3-0	Select the interrupt level ^{Note1} for Parallel Port.

8.8.7 Parallel Port DMA Channel Select (Index=74h, Default=03h)

Bit	Description
7-3	Reserved with default "00h."
2-0	Select the DMA channel ^{Note2} for Parallel Port. 5h~7h are not available.

8.8.8 Parallel Port Special Configuration Register (Index=F0h, Default=03h)

Bit	Description
7-4	Reserved
3	1: POST Data Port Disable. 0: POST Data Port Enable.
2	1: IRQ sharing. 0: Normal.
1-0	Parallel Port Modes. 00: Standard Parallel Port mode (SPP) 01: EPP mode 10: ECP mode 11: EPP mode & ECP mode

If bit 1 is set, ECP mode is enabled. If bit 0 is set, EPP mode is enabled. These two bits are independent. However, according to the EPP spec., when Parallel Port Primary Base Address LSB Register bit 2 is set to 1, the EPP mode cannot be enabled.

8.9 Environment Controller Configuration Registers (LDN=04h)

8.9.1 Environment Controller Activate Register (Index=30h, Default=00h)

Bit	Description
7-1	Reserved
0	Environment Controller Enable. 1: Enabled. 0: Disabled. This is a read/write register.

8.9.2 Environment Controller Base Address MSB Register (Index=60h, Default=02h)

Bit	Description
7-4	Read only as "0h" for Base Address [15:12].
3-0	Read/write , mapped as Base Address [11:8].

8.9.3 Environment Controller Base Address LSB Register (Index=61h, Default=90h)

Bit	Description
7-3	Read/write , mapped as Base Address [7:3].
2-0	Read only as "000b."

8.9.4 PME Direct Access Base Address MSB Register (Index=62h, Default=02h)

Bit	Description
7-4	Read only as "0h" for Base Address [15:12].
3-0	Read/write , mapped as Base Address [11:8].

8.9.5 PME Direct Access Base Address LSB Register (Index=63h, Default=30h)

Bit	Description
7-3	Read/write , mapped as Base Address [7:3].
2-0	Read only as "000b."

8.9.6 Environment Controller Interrupt Level Select (Index=70h, Default=09h)

Bit	Description
7-4	Reserved with default "0h."
3-0	Select the interrupt level ^{Note1} for Environment Controller.

8.9.7 APC/PME Event Enable Register (PER) (Index=F0h, Default=00h)

Bit	Description
7	It is set to 1 when VCCH is OFF. Write 1 to clear this bit. This bit is ineffective if a 0 is written to this bit.
6	0: Smart Card Reader card detects event disabled. 1: Smart Card Reader card detects event enabled.
5	0: RING# event disabled. 1: RING# event enabled.
4	0: PS/2 Mouse event disabled. 1: PS/2 Mouse event enabled.
3	0: Keyboard event disabled. 1: Keyboard event enabled.
2	0: RI2# event disabled. 1: RI2# event enabled.
1	0: RI1# event disabled. 1: RI1# event enabled.
0	0: CIR event disabled. 1: CIR event enabled.

8.9.8 APC/PME Status Register (PSR) (Index=F1h, Default=00h)

Bit	Description
7	It is set to 1 when VCC is ON at previous AC power failure and 0 when VCC is OFF.
6	0: No Smart Card Reader card detects event Detected. 1: Smart Card Reader card detects event Detected.
5	0: No RING# Event Detected. 1: RING# Event Detected.
4	0: No PS/2 Mouse Event Detected. 1: PS/2 Mouse Event Detected.
3	0: No Keyboard Event Detected. 1: Keyboard Event Detected.
2	0: No RI2# Event Detected. 1: RI2# Event Detected.
1	0: No RI1# Event Detected. 1: RI1# Event Detected.
0	0: No CIR event Detected. 1: CIR event Detected.

8.9.9 APC/PME Control Register 1 (PCR 1) (Index=F2h, Default=00h)

Bit	Description
7	PER and PSR normal run access enable.
6	PME# Output Control 0: Enabled. 1: Disabled.
5	This bit is restored automatically to the previous VCC state before power failure occurs.
4	Disables all APC events after the power failure occurs, excluding PANSWH#.
3	Keyboard Event Mode Selection when VCC is ON 1: Determined by PCR 2. 0: Pulse falling edge on KCLK.
2	Mouse Event when VCC is OFF 1: Click Key twice sequentially. 0: Pulse falling edge on MCLK.
1	Mouse Event when VCC is ON 1: Click Key twice sequentially. 0: Pulse falling edge on MCLK.
0	RING# Event Mode Selection 1: Pulse train mode. 0: Pulse falling edge mode.

8.9.10 Environment Controller Special Configuration Register (Index=F3h, Default=00h)

Bit	Description
7-1	Reserved
0	1: IRQ sharing. 0: Normal.

8.9.11 APC/PME Control Register 2 (PCR 2) (Index=F4h, Default=00h)

Bit	Description
7	Disable KCLK/KDAT and MCLK/MDAT auto-swap. 0: Enabled. 1: Disabled.
6	SIR/ASKIR and CIR use the same pins (Pin 66 and Pin 70).
5	PSON# State when VCCH is Switched from OFF to ON. 0: High-Z (default power OFF). 1: Inverting of PSIN.
4	Masks PANSWH# power-on Event.
3-2	Key Number of the Keyboard power-up Event. 00: 5 (Key string mode), 3 (Stroke keys at same time mode) 01: 4 (Key string mode), 2 (Stroke keys at same time mode) 10: 3 (Key string mode), 1 (Stroke keys at same time mode) 11: 2 (Key string mode), Reserved (Stroke keys at same time mode)
1-0	Keyboard power-up Event Mode Selection. 00: KCLK falling edge 01: Key string mode 10: Stroke keys at same time mode 11: Reserved

8.9.12 APC/PME Special Code Index Register (Index=F5h)

Bit	Description
7-6	Reserved (should be "00").
5-0	Indicate which Identification Key Code or CIR code register is to be read/written via 0xF6.

8.9.13 APC/PME Special Code Data Register (Index=F6h)

There are 5 bytes for Key String mode, 3 bytes for Stroke Keys at same time mode, and CIR event codes.

8.10 KBC (keyboard) Configuration Registers (LDN=05h)

8.10.1 KBC (keyboard) Activate (Index=30h, Default=01h or 00h)

Bit	Description
7-1	Reserved
0	KBC (keyboard) Enable. 1: Enabled. 0: Disabled. This is a read/write register. The default value depends on the state of the DTR1# when LRESET# is activated. The default value is 1b for the high state of DTR1# when LRESET# is activated. It is 0b for the low state of DTR1# when LRESET# is activated.

8.10.2 KBC (keyboard) Data Base Address MSB Register (Index=60h, Default=00h)

Bit	Description
7-4	Read only as "0h" for Base Address [15:12].
3-0	Read/write , mapped as Base Address [11:8].

8.10.3 KBC (keyboard) Data Base Address LSB Register (Index=61h, Default=60h)

Bit	Description
7-0	Read/write , mapped as Base Address[7:0].

8.10.4 KBC (keyboard) Command Base Address MSB Register (Index=62h, Default=00h)

Bit	Description
7-4	Read only as "0h" for Base Address[15:12].
3-0	Read/write , mapped as Base Address[11:8].

8.10.5 KBC (keyboard) Command Base Address LSB Register (Index=63h, Default=64h)

Bit	Description
7-0	Read/write , mapped as Base Address[7:0].

8.10.6 KBC (keyboard) Interrupt Level Select (Index=70h, Default=01h)

Bit	Description
7-4	Reserved with default "0h."
3-0	Select the interrupt level ^{Note1} for KBC (keyboard).

8.10.7 KBC (keyboard) Interrupt Type (Index=71h, Default=02h)

This register indicates the type of interrupt set for KBC (keyboard) and is **read only** as "02h" when bit 0 of the

KBC (keyboard) Special Configuration Register is cleared. When bit 0 is set, this type of interrupt can be selected as level or edge trigger.

Bit	Description
7-2	Reserved
1	1: High Level. 0: Low Level.
0	1: Level Type. 0: Edge Type.

8.10.8 KBC (keyboard) Special Configuration Register (Index=F0h, Default=00h)

Bit	Description
7	Reserved
6	Reserved
5	Reserved
4	1: IRQ sharing. 0: Normal.
3	1: KBC's clock 8 MHz. 0: KBC's clock 12 MHz.
2	1: Key lock enabled. 0: Key lock disabled.
1	1: Type of interrupt of KBC (keyboard) can be changed. 0: Type of interrupt of KBC (keyboard) is fixed.
0	1: Enables the External Access ROM of 8042. 0: Internal built-in ROM is used.

8.11 KBC (mouse) Configuration Registers (LDN=06h)

8.11.1 KBC (mouse) Activate (Index=30h, Default=00h)

Bit	Description
7-1	Reserved
0	KBC (mouse) Enable. 1: Enabled. 0: Disabled.

8.11.2 KBC (mouse) Interrupt Level Select (Index=70h, Default=0Ch)

Bit	Description
7-4	Reserved with default "0h."
3-0	Select the interrupt level ^{Note1} for KBC (mouse).

8.11.3 KBC (mouse) Interrupt Type (Index=71h, Default=02h)

This register indicates the type of interrupt used for KBC (mouse) and is **read only** as “02h” when bit 0 of the KBC (mouse) Special Configuration Register is cleared. When bit 0 is set, the type of interrupt can be selected as level or edge trigger.

Bit	Description
7-2	Reserved
1	1: High Level. 0: Low Level.
0	1: Level Type. 0: Edge Type.

8.11.4 KBC (mouse) Special Configuration Register (Index=F0h, Default=00h)

Bit	Description
7-2	Reserved with default “00h.”
1	1: IRQ sharing. 0: Normal.
0	1: Type of interrupt of KBC (mouse) can be changed. 0: Type of interrupt of KBC (mouse) is fixed.

8.12 GPIO Configuration Registers (LDN=07h)

8.12.1 SMI# Normal Run Access Base Address MSB Register (Index=60h, Default=00h)

Bit	Description
7-4	Read only as “0h” for Base Address [15:12].
3-0	Read/write mapped as Base Address [11:8].

8.12.2 SMI# Normal Run Access Base Address LSB Register (Index=61h, Default=00h)

Bit	Description
7-0	Read/write mapped as Base Address [7:0].

8.12.3 Simple I/O Base Address MSB Register (Index=62h, Default=00h)

Bit	Description
7-4	Read only as “0h” for Base Address [15:12].
3-0	Read/write mapped as Base Address [11:8].

8.12.4 Simple I/O Base Address LSB Register (Index=63h, Default=00h)

Bit	Description
7-0	Read/write mapped as Base Address [7:0].

8.12.5 Panel Button De-bounce Base Address MSB Register (Index=64h, Default=00h)

Bit	Description
7-4	Read only as “0h” for Base Address [15:12].
3-0	Read/write mapped as Base Address [11:8].

8.12.6 Panel Button De-bounce Base Address LSB Register (Index=65h, Default=00h)

Bit	Description
7-0	Read/write, mapped as Base Address [7:0].

8.12.7 Panel Button De-bounce Interrupt Level Select Register (Index=70h, Default=00h)

Bit	Description
7-4	Reserved
3-0	Select the interrupt level ^{Note1} for Panel Button De-bounce.

8.12.8 Watch Dog Timer Control Register (Index=71h, Default=00h)

Bit	Description
7	WDT is reset upon a CIR interrupt.
6	WDT is reset upon a read or a write to the Game Port base address.
5	WDT is reset upon a KBC (keyboard) interrupt.
4	WDT is reset upon a KBC (mouse) interrupt.
3-2	Reserved
1	Force Time-out. This bit is self-clearing.
0	WDT Status 1: WDT value reaches 0. 0: WDT value is not 0.

8.12.9 Watch Dog Timer Configuration Register (Index=72h, Default=00h)

Bit	Description
7	WDT Time-out value select. 1: Second. 0: Minute.
6	WDT output through KRST (pulse) enable.
5-4	Reserved
3-0	Select the interrupt level Note1 for WDT.

8.12.10 Watch Dog Timer Time-Out Value Register (Index=73h, Default=00h)

Bit	Description
7-0	WDT time-out value 7-0.

8.12.11 GPIO Pin Set 1, 2, 3, 4 and 5 Polarity Registers (Index=B0h, B1h, B2h, B3h and B4h, Default=00h)

These registers are used to program the GPIO pin type as polarity inverting or non-inverting.

Bit	Description
7-0	1: Inverting. 0: Non-inverting.

8.12.12 GPIO Pin Set 1, 2, 3, 4 and 5 Pin Internal Pull-up Enable Registers (Index=B8h, B9h, BAh, BBh and BCh, Default=00h)

These registers are used to enable the GPIO pin internal pull-up.

Bit	Description
7-0	1: Enabled. 0: Disabled.

8.12.13 Simple I/O Set 1, 2, 3, 4 and 5 Enable Registers (Index=C0h, C1h, C2h, C3h and C4h, Default=00h)

These registers are used to select the function as the Simple I/O function or the Alternate function.

Bit	Description
7-0	1: Simple I/O function. 0: Alternate function.

8.12.14 Simple I/O Set 1, 2, 3, 4 and 5 Output Enable Registers (Index=C8h, C9h, CAh, CBh and CCh, Default=00h)

These registers are used to determine the direction of the Simple I/O.

Bit	Description
7-0	0: Input mode. 1: Output mode.

8.12.15 Panel Button De-bounce Control Register (Index=D0h, Default=00h)

Bit	Description
7-5	Reserved
4	IRQ sharing enable.
3	IRQ output enable.
2	IRQ output type.
1-0	De-bounce time selection. 00: 8 ms (6 ms ignored, 8 ms passed) 01: 16 ms (12 ms ignored, 16 ms passed) 10: 32 ms (24 ms ignored, 21 ms passed) 11: 64 ms (48 ms ignored, 64 ms passed)

8.12.16 Panel Button De-bounce Set 1, 2, 3, 4 and 5 Enable Registers (Index=D1h, D2h, D3h, D4h and D5h, Default=00h)

These registers are used to enable Panel Button De-bounce for each pin.

Bit	Description
7-0	1: Enabled. 0: Disabled.

8.12.17 IRQ3-7, 9-12 and 14-15 External Routing Input Pin Mapping Registers (Index=E3h-E7h, E9h-ECh and EEh-EFh, Default=00h)

These registers are used to determine the external routing input pin mappings of IRQ3-7, 9-12 and 14-15.

Bit	Description
7	Reserved
6	IRQ Sharing enable.
5-0	Input pin Location. Please see Location mapping table ^{Note4} .

8.12.18 SMI# Control Register 1 (Index=F0h, Default=00h)

Bit	Description
7	Enables the generation of an SMI# due to MIDI's IRQ (EN_MIDI).
6	Enables the generation of an SMI# due to KBC (Mouse)'s IRQ (EN_MIRQ).
5	Enables the generation of an SMI# due to KBC (Keyboard)'s IRQ (EN_KIRQ).
4	Enables the generation of an SMI# due to Environment Controller's IRQ (EN_ECIRQ).
3	Enables the generation of an SMI# due to Parallel Port's IRQ (EN_PIRQ).
2	Enables the generation of an SMI# due to Serial Port 2's IRQ (EN_S2IRQ).
1	Enables the generation of an SMI# due to Serial Port 1's IRQ (EN_S1IRQ).
0	Enables the generation of an SMI# due to FDC's IRQ (EN_FIRQ).

8.12.19 SMI# Control Register 2 (Index=F1h, Default=00h)

Bit	Description
7	Forces to clear all the SMI# status register bits, non-sticky.
6	0: Edge trigger. 1: Level trigger.
5	Reserved
4	Enables the generation of an SMI# due to SD's IRQ (EN_EN).
3	Enables the generation of an SMI# due to MS's IRQ (EN_MS).
2	Enables the generation of an SMI# due to WDT's IRQ (EN_WDT).
1	Enables the generation of an SMI# due to CIR's IRQ (EN_CIR).
0	Enables the generation of an SMI# due to PBD's IRQ (EN_PBD).

8.12.20 SMI# Status Register 1 (Index=F2h, Default=00h)

This register is used to read the status of SMI# inputs.

Bit	Description
7	MIDI's IRQ.
6	KBC (PS/2 Mouse)'s IRQ.
5	KBC (Keyboard)'s IRQ.
4	Environment Controller's IRQ.
3	Parallel Port's IRQ.
2	Serial Port 2's IRQ.
1	Serial Port 1's IRQ.
0	FDC's IRQ.

8.12.21 SMI# Status Register 2 (Index=F3h, Default=00h)

This register is used to read the status of SMI# inputs.

Bit	Description
7-5	Reserved
4	SD's IRQ. (Secure Digital I/F)
3	MS's IRQ. (Memory Stick I/F)
2	WDT's IRQ.
1	CIR's IRQ.
0	PBD's IRQ.

8.12.22 SMI# Pin Mapping Register (Index=F4h, Default=00h)

Bit	Description
7-6	Reserved
5-0	SMI# Pin Location. Please see Location mapping table ^{Note4} .

8.12.23 Hardware Monitor Thermal Output Pin Mapping Register (Index=F5h, Default=00h)

Bit	Description
7-6	Reserved
5-0	Thermal Output Pin Location. Please see Location mapping table ^{Note4} .

8.12.24 Hardware Monitor Alert Beep Pin Mapping Register (Index=F6h, Default=00h)

Bit	Description
7-6	Reserved
5-0	Alert Beep Pin Location. Please see Location mapping table ^{Note4} .

8.12.25 Keyboard Lock Pin Mapping Register (Index=F7h, Default=00h)

Bit	Description
7-6	Reserved
5-0	Keyboard Lock Pin Location. Please see Location mapping table ^{Note4} .

8.12.26 GP LED Blinking 1 Pin Mapping Register (Index=F8h, Default=00h)

Bit	Description
7-6	Reserved
5-0	GP LED Blinking 1 Location. Please see Location mapping table ^{Note4} .

8.12.27 GP LED Blinking 1 Control Register (Index=F9h, Default=00h)

Bit	Description
7-4	Reserved
3	GP LED Blinking 1 short low pulse enabled.
2-1	GP LED 1 Frequency Control. 00: 2.72 ± 20% Hz 01: 0.68 ± 20% Hz 10: 0.17 ± 20% Hz 11: 0.085 ± 20% Hz
0	GP LED Blinking 1 Output low enabled.

8.12.28 GP LED Blinking 2 Pin Mapping Register (Index=FAh, Default=00h)

Bit	Description
7-6	Reserved
5-0	GP LED Blinking 2 Location. Please see Location mapping table ^{Note4} .

8.12.29 GP LED Blinking 2 Control Register (Index=FBh, Default=00h)

Bit	Description
7-4	Reserved
3	GP LED Blinking 2 short low pulse enabled.
2-1	GP LED 2 Frequency Control. 00: 2.72 ± 20% Hz 01: 0.68 ± 20% Hz 10: 0.17 ± 20% Hz 11: 0.085 ± 20% Hz
0	GP LED Blinking 2 Output low enabled.

8.13 MIDI Port Configuration Registers (LDN=08h)
8.13.1 MIDI Port Activate (Index=30h, Default=00h)

Bit	Description
7-1	Reserved
0	MIDI Port Enable. 1: Enabled. 0: Disabled.

8.13.2 MIDI Port Base Address MSB Register (Index=60h, Default=03h)

Bit	Description
7-4	Read only with "0h" for Base Address[15:12].
3-0	Read/write, mapped as Base Address[11:8].

8.13.3 MIDI Port Base Address LSB Register (Index=61h, Default=00h)

Bit	Description
7-3	Read/write, mapped as Base Address[7:3].
2-0	Read only as "000b."

8.13.4 MIDI Port Interrupt Level Select (Index=70h, Default=0Ah)

Bit	Description
7-4	Reserved with default "0h."
3-0	Select the interrupt level ^{Note1} for MIDI Port.

8.13.5 MIDI Port Special Configuration Register (Index=F0h, Default=00h)

Bit	Description
7-3	Reserved with default "00h."
2-1	Receive FIFO trigger level. 00: 1 byte 01: 4 bytes 10: 8 bytes 11: 14 bytes
0	1: IRQ sharing. 0: Normal.

8.14 Game Port Configuration Registers (LDN=09h)

8.14.1 Game Port Activate (Index=30h, Default=00h)

Bit	Description
7-1	Reserved
0	Game Port Enable. 1: Enabled. 0: Disabled.

8.14.2 Game Port Base Address MSB Register (Index=60h, Default=02h)

Bit	Description
7-4	Read only with "0h" for Base Address [15:12].
3-0	Read/write mapped as Base Address [11:8].

8.14.3 Game Port Base Address LSB Register (Index=61h, Default=01h)

Bit	Description
7-0	Read/write mapped as Base Address [7:0].

8.15 Consumer IR Configuration Registers (LDN=0Ah)

8.15.1 Consumer IR Activate (Index=30h, Default=00h)

Bit	Description
7-1	Reserved
0	Consumer IR Enable. 1: Enabled. 0: Disabled.

8.15.2 Consumer IR Base Address MSB Register (Index=60h, Default=03h)

Bit	Description
7-4	Read only with "0h" for Base Address [15:12].
3-0	Read/write mapped as Base Address [11:8].

8.15.3 Consumer IR Base Address LSB Register (Index=61h, Default=10h)

Bit	Description
7-3	Read/write , mapped as Base Address [7:3].
2-0	Read only as "000b."

8.15.4 Consumer IR Interrupt Level Select (Index=70h, Default=0Bh)

Bit	Description
7-4	Reserved with default "0h."
3-0	Select the interrupt level ^{Note1} for Consumer IR.

8.15.5 Consumer IR Special Configuration Register (Index=F0h, Default=00h)

Bit	Description
7-1	Reserved with default "00h."
0	1: IRQ sharing. 0: Normal.

8.16 Memory Stick Configuration Registers (LDN=0Bh)

8.16.1 Memory Stick Activate (Index=30h, Default=00h)

Bit	Description
7-1	Reserved
0	Memory Stick Enable 1: Enabled. 0: Disabled.

8.16.2 Memory Stick Base Address MSB Register (Index=60h, Default=02h)

Bit	Description
7-4	Read only with "0h" for Base Address [15:12].
3-0	Read/write mapped as Base Address [11:8].

8.16.3 Memory Stick Base Address LSB Register (Index=61h, Default=20h)

Bit	Description
7-3	Read/write mapped as Base Address [7:3].
2-0	Read only as "000b."

8.16.4 Memory Stick Interrupt Level Select (Index=70h, Default=05h)

Bit	Description
7-4	Reserved with default "0h."
3-0	Select the interrupt level ^{Note1} for Memory Stick.

8.16.5 Memory Stick DMA Channel Select (Index=74h, Default=05h)

Bit	Description
7-3	Reserved with default "0h."
2-0	Select the DMA channel ^{Note2} for Memory Stick.

8.16.6 Memory Stick Special Configuration Register (Index=F0h, Default=00h)

Bit	Description
7-2	Reserved with default "00h."
1	Pin_Select Selects Memory Stick I/F pin group. The used pins' multi-function selection registers should be set as media I/F. Additionally, the other media I/F (SD, Smart Card) cannot be used. 1: Pins 31, 32, 33, 34, 78, and 84 are used. (Smart Card I/F should be disabled) 0: Pins 13, 16, 17, 18, 19, and 36 are used. (SD I/F A should be disabled)
0	IRQ_mode. 1: IRQ sharing. 0: Normal.

8.17 SD Configuration Registers (LDN=0Ch)

8.17.1 SD Activate (Index=30h, Default=00h)

Bit	Description
7-1	Reserved
0	SD Enable 1: Enabled. 0: Disabled.

8.17.2 SDBase Address MSB Register (Index=60h, Default=02h)

Bit	Description
7-4	Read only with "0h" for Base Address [15:12].
3-0	Read/write, mapped as Base Address [11:8].

8.17.3 SD Base Address LSB Register (Index=61h, Default=30h)

Bit	Description
7-1	Read/write, mapped as Base Address [7:1].
0	Read only as "0b."

8.17.4 SD Interrupt Level Select (Index=70h, Default=09h)

Bit	Description
7-4	Reserved with default "0h."
3-0	Select the interrupt level ^{Note1} for SD.

8.17.5 SD DMA Channel Select (Index=74h, Default=06h)

Bit	Description
7-3	Reserved with default "0h."
2-0	Select the DMA channel ^{Note2} for SD.

8.17.6 SD Special Configuration Register (Index=F0h, Default=00h)

Bit	Description
7-3	Reserved with default "00h."
2	Port_1_Enable. Enable SD Port 1 (pin port group B). The Serial Port 2 cannot be used as COM port. 1: Enable. 0: Disable.
1	Port_0_Enable. Enable SD Port 0 (pin port group A). The used pins' multi-function selection registers should be set as media I/F. Additionally, 13, 16, 17, 18, 19, and 36 cannot be used as the Memory Stick I/F. 1: Enable. 0: Disable.
0	IRQ_mode. 1: IRQ sharing. 0: Normal.

Note 1: Interrupt level mapping

Fh-Dh: not valid

Ch: IRQ12

.

3h: IRQ3

2h: not valid

1h: IRQ1

0h: no interrupt selected

Note 2: DMA channel mapping

7h: DMA7
6h: DMA6
5h: DMA5
7h-5h: not valid
4h: no DMA channel selected
3h: DMA3
2h: DMA2
1h: DMA1
0h: DMA0

Note 3: Except the standard mode, COM1 and COM2 cannot be selected in the same time mode.

Note 4: The Location mapping table

Location	Description
001 000	GP10 (pin 84) Powered by VCCH
001 001	GP11 (pin 34)
001 010	GP12 (pin 33)
001 011	GP13 (pin 32)
001 100	GP14 (pin 31)
001 101	GP15 (pin 30)
001 110	GP16 (pin 29)
001 111	GP17 (pin 28)
010 000	GP20 (pin 27)
010 001	GP21 (pin 26)
010 010	GP22 (pin 25)
010 011	GP23 (pin 24)
010 100	GP24 (pin 23)
010 101	GP25 (pin 22)
010 110	GP26 (pin 21)
010 111	GP27 (pin 20)
011 000	GP30 (pin 19)
011 001	GP31 (pin 18)
011 010	GP32 (pin 17)
011 011	GP33 (pin 16)
011 100	GP34 (pin 14)
011 101	GP35 (pin 13)
011 110	GP36 (pin 12)
011 111	GP37 (pin 11)
100 000	GP40 (pin 79) Powered by VCCH
100 001	GP41 (pin 78) Powered by VCCH
100 010	GP42 (pin 76) Powered by VCCH
100 011	GP43 (pin 75) Powered by VCCH
100 100	GP44 (pin 72) Powered by VCCH
100 101	GP45 (pin 71) Powered by VCCH
100 110	GP46 (pin 70) Powered by VCCH
100 111	GP47 (pin 66)
101 000	GP50 (pin 48)
101 001	GP51 (pin 10)
101 010	GP52 (pin 9)
101 011	GP53 (pin 77) Powered by VCCH
101 100	GP54 (pin 73) Powered by VCCH
101 101	GP55 (pin 85) Powered by VCCH
others	Reserved

9. Functional Description

9.1 LPC Interface

The IT8722F supports the peripheral site of the LPC I/F as described in the LPC Interface Specification Rev.1.0 (Sept. 29, 1997). In addition to the required signals (LAD3-0, LFRAME#, LRESET#, LCLK (which is the same as PCICLK.), the IT8722F also supports LDRQ#, SERIRQ and PME#.

9.1.1 LPC Transactions

The IT8722F supports some parts of the cycle types described in the LPC I/F specification. Memory read and Memory write cycles are used for the Flash I/F. I/O read and I/O write cycles are used for the programmed I/O cycles. DMA read and DMA write cycles are used for DMA cycles. All of these cycles are characteristic of the single byte transfer.

For LPC host I/O read or write transactions, the Super I/O module processes a positive decoding and the LPC interface can respond to the result of the current transaction by sending out SYNC values on LAD[3:0] signals or leave LAD[3:0] tri-state depending on its result.

For DMA read or write transactions, the LPC interface will have reactions according to the DMA requests from the DMA devices in the Super I/O modules and decides whether to ignore the current transaction or not.

The FDC and ECP are 8-bit DMA devices, so if the LPC Host initializes a DMA transaction with data size of 16/32 bits, the LPC interface will process the first 8-bit data and response with a SYNC ready (0000b) which will terminate the DMA burst. The LPC interface will then reissue another LDRQ# message to assert DREQn after finishing the current DMA transaction.

9.1.2 LDRQ# Encoding

The Super I/O module provides two DMA devices: the FDC, the ECP, the MS, and the SD. The LPC Interface provides LDRQ# encoding to reflect the DREQ [7:5] and DREQ [3:0] statuses. Two LDRQ# messages or different DMA channels may be issued back-to-back to trace DMA requests quickly. However, four PCI clocks will be inserted between two LDRQ# messages of the same DMA channel to guarantee that there is at least 10 PCI clocks for one DMA request to change its status. (The LPC host will decode these LDRQ# messages and send those decoded DREQn to the legacy DMA controller which runs at 4 MHz or 33/8 MHz).

9.2 Serialized IRQ

The IT8722F follows the specification of Serialized IRQ Support for PCI System, Rev. 6.0, September 1, 1995, to support the serialized IRQ feature and is able to interface most PC chipsets. The IT8722F encodes the parallel interrupts to an SERIRQ which will be decoded by the chipset with built-in Interrupt Controllers (two 8259 compatible modules).

9.2.1 Continuous Mode

When in the Continuous mode, the SIRQ host initiates the Start frame of each SERIRQ sequence after sending out the Stop frame by itself. (The next Start frame may or may not begin immediately after the turn-around state of current Stop frame.) The SERIRQ is always activated and SIRQ host keeps polling all the IRQn and system events, even though no IRQn status is changed. The SERIRQ enters the Continuous mode following a system reset.

9.2.2 Quiet Mode

In the Quiet mode, when one SIRQ Slave detects its input IRQn/events have been changed, it may initiate the first clock of the Start frame. Then the SIRQ host can follow to complete the SERIRQ sequence. In the Quiet mode, the SERIRQ has no activity following the Stop frame until it is initiated by SIRQ Slave, which implies that low activity is equal to low mode power consumption.

9.2.3 Waveform Samples of SERIRQ Sequence

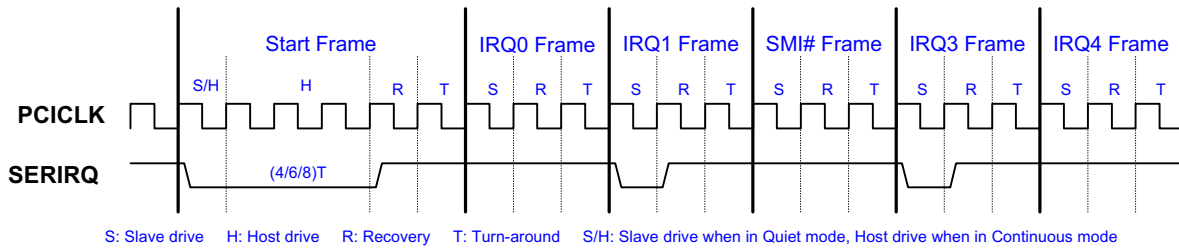

Figure 9-1. Start Frame Timing

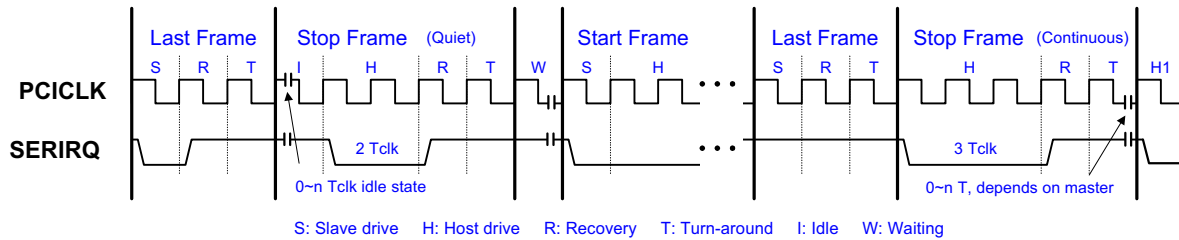

Figure 9-2. Stop Frame Timing

9.2.4 SERIRQ Sampling Slot

Slot Number	IRQn /Events	# of Clocks Past Start	IT8722F
1	IRQ0	2	-
2	IRQ1	5	Y
3	SMI#	8	Y
4	IRQ3	11	Y
5	IRQ4	14	Y
6	IRQ5	17	Y
7	IRQ6	20	Y
8	IRQ7	23	Y
9	IRQ8	26	Y
10	IRQ9	29	Y
11	IRQ10	32	Y
12	IRQ11	35	Y
13	IRQ12	38	Y
14	IRQ13	41	-
15	IRQ14	44	Y
16	IRQ15	47	Y
17	IOCHCK#	50	-
18	INTA#	53	-
19	INTB#	56	-
20	INTC#	59	-
21	INTD#	62	-
32:22	Unassigned	95 / 65	-

9.3 General Purpose I/O

The IT8722F provides five sets of flexible I/O control and special functions for the system designers via a set of multi-functional General Purpose I/O pins (GPIO). The GPIO functions will not be performed unless the related enable bits of the GPIO Multi-function Pin Selection registers (Index 25h, 26h, 27h, 28h and 29h of the Global Configuration Registers) are set. The GPIO functions include the simple I/O function and alternate function, and the function selection is determined by the Simple I/O Enable Registers (LDN=07h, Index=C0h, C1h, C2h, C3h and C4h).

The Simple I/O function includes a set of registers, which correspond to the GPIO pins. All control bits are divided into five registers. The accessed I/O ports are programmable and are five consecutive I/O ports (Base Address+0, Base Address+1, Base Address+2, Base Address+3, Base Address+4). Base Address is programmed on the registers of GPIO Simple I/O Base Address LSB and MSB registers (LDN=07h, Index=60h and 61h).

The Alternate Function provides several special functions for users, including Watch Dog Timer, SMI# output routing, External Interrupt routing, Panel Button De-bounce, Keyboard Lock input routing, LED Blinking, Thermal output routing, and Beep output routing. The last two are the sub-functions of Hardware Monitor.

The Panel Button De-bounce is an input function. After the panel button de-bounce is enabled, a related status bit will be set when an active low pulse is detected on the GPIO pin. The status bits will be cleared by writing 1's to them. Panel Button De-bounce Interrupt will be issued if any of the status bit is set. However, the new setting status will not issue another interrupt unless the previous status bit is cleared before being set.

The Key Lock function locks the keyboard to inhibit the keyboard interface. The programming method is to set bit 2 on the register Index F0h of KBC (keyboard) (LDN=5). The pin location mapping and Index F7h also must be programmed correctly.

The Blinking function provides a low frequency blink output. By connecting to some external components, it can be used to control a power LED. There are several frequencies that can be selected.

The Watch Dog Timer (WDT) function is constituted by a time counter, a time-out status register, and the timer reset control logic. The time-out status bit may be mapped to an interrupt or KRST# through the WDT Configuration register. The WDT has a programmable time-out range from 1 to 255 minutes or 1 to 255 seconds. The unit is also programmable, either a minute or a second, via bit7 of the WDT Configuration register. When the WDT Time-out Value register is set to a non-zero value, the WDT loads the value and begins counting down from the value. When the value reaches to 0, the WDT status register will be set. There are many system events that can reload the non-zero value into the WDT, which includes a CIR interrupt, a Keyboard Interrupt, a Mouse Interrupt, or I/O read/write to the Game Port base address. The effect on the WDT for each of the events may be enabled or disabled through bits in the WDT control register. No matter what value in the time counter is, the host may force a time-out to occur by writing a "1" to the bit 1 of the WDT Configuration register.

The External Interrupt routing function provides a useful feature for motherboard designers. Through this function, the parallel interrupts of other on-board devices can be easily re-routed into the Serial IRQ.

The SMI# is a non-maskable interrupt dedicated to the transparent power management. It consists of different enabled interrupts generated from each of the functional blocks in the IT8722F. The interrupts are redirected as the SMI# output via the SMI# Control Register 1 and SMI# Control Register 2. The SMI# Status Registers 1 and 2 are used to read the status of the SMI input events. All the SMI# Status Register bits can be cleared when the corresponding source events become invalidated. These bits can also be cleared by writing 1 to bit 7 of SMI# Control Register 2 no matter the events of the corresponding sources are invalidated or not. The SMI# events can be programmed as pulse mode or level mode whenever an SMI# event occurs. The logic equation of the SMI# event is described below:

$SMI\# \text{ event} = (EN_FIRQ \text{ and } FIRQ) \text{ or } (EN_S1IRQ \text{ and } S1IRQ) \text{ or } (EN_S2IRQ \text{ and } S2IRQ) \text{ or } (EN_PIRQ \text{ and } PIRQ) \text{ or } (EN_EC \text{ and } EC_SMI) \text{ or } (EN_PBDIRQ \text{ or } PBDIRQ).$

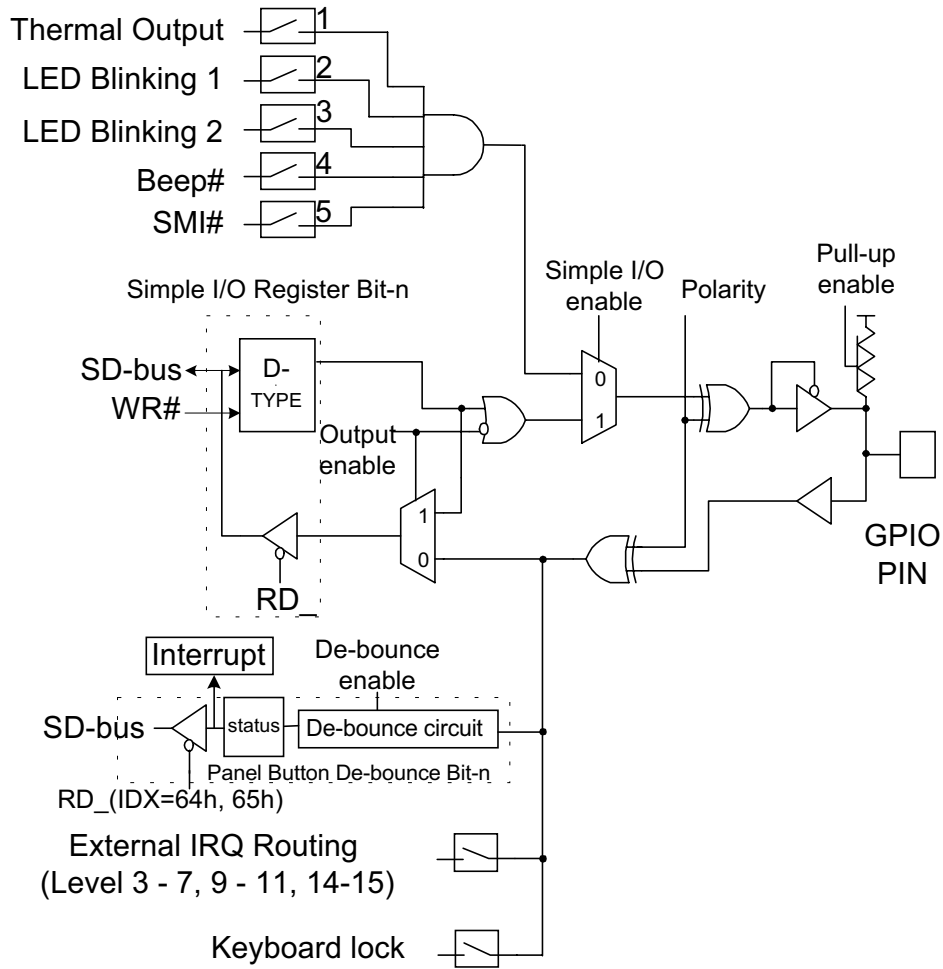

Figure 9-3. General Logic of GPIO Function

9.4 Advanced Power Supply Control and Power Management Event (PME#)

The circuit for advanced power supply control (APC) provides five power-up events, Keyboard, Mouse, CIR, Smart Card Reader card detect and RING#. When any of these five events is true, PWRON# will perform a low state until VCC is switched to the ON state. The five events are as follows:

1. Detection of RING# pulse or pulse train on the RING# input pin
2. Detection of KCLK edge or special pattern of KCLK and KDAT. The special pattern of KCLK means pressing pre-set key string sequentially, and KDAT means pressing pre-set keys simultaneously.
3. Detection of MCLK edge or special pattern of MCLK and MDAT. The special pattern of MCLK and MDAT means clicking on any mouse button twice sequentially.
4. Receiving CIR patterns are matched the previous stored pattern stored at the APC/PME Special Code Index and Data Register.
5. Detection of the Smart Card Reader Card Detect pulse on the SCRPRES# input pin

The PANSWH# and PSON# are especially designed for the system. PANSWH# serves as a main power switch input which is wire-AND to the APC output PWRON#. PSON# is the ATX Power control output, which is a power-failure gating circuit. The power-failure gating circuit is responsible for gating the PSIN input until PANSWH# becomes active when the VCCH is switched from OFF to ON.

The power-failure gating circuit can be disabled by setting the APC/PME Control Register 2 (LDN=04h, index F4h, bit 5). The gating circuit also provides an auto-restore function. When the bit 5 of PCR1 is set, the previous PSON# state will be restored when the VCCH is switched from OFF to ON.

The RING# function is used to power on the system from modem, fax, etc. It can be programmed to detect a pulse train with pulse low.

The Mask PWRON# Activation bit (bit 4 of PCR 1) is used to mask all Power-up events except Switch on event when the VCCH state is just switched from FAIL to OFF. In other words, when this bit is set and the power state is switched from FAIL to OFF, the only validated function is PANSWH#.

The PCR2 register is responsible for determining the Keyboard power up events and APC conditions. Bit 4 is used to mask the PANSWH# power-on event on the PWRON# pin. To enable this bit, the keyboard power-up event should be enabled and set by (1) pressing pre-set key string sequentially or (2) stroking pre-set keys simultaneously. The APC/PME# special code index and data registers are used to specify the special key codes in the special power-up events of (1) pressing pre-set key string sequentially or (2) stroking pre-set keys simultaneously.

A CIR event is generated if the input CIR RX pattern is the same as the previous stored pattern stored at PME Special Code Index and Data Registers (LDN=04h, Index=F5h and F6h). The total maximum physical codes are nineteen bytes (from Index 20h to 32h). The first byte (Index 20h) is used to specify the pattern length (in bytes). Bits [7:4] are used when VCC is ON; and Bits [3:0] are used when VCC is OFF. The actual length will be bit[7:4] (or bit[3:0]) + 3. For most of the CIR protocols, the first several bytes are always the same for each key (or pattern). The differences are always placed in the last several bytes. Thus, the system designer can program the IT8722F to generate a CIR PME# event as any keys when VCC is ON and a special key (i.e. POWER-ON) when VCC is OFF.

The Smart Card Reader Card Detect event is used to power on the system when any Integrated Circuit Card is inserted in the Smart Card Reader. When inserted, a pulse will be generated on the SCRPRES# input pin. If the relative enabled bit is enabled, the power-up event will also be generated.

All APC registers (Index=F0h, F2h, F4h, F5h and F6h) are powered by back-up power (VBAT) when VCCH is OFF.

PME# is used to wake up the system from a low-power state (S1-S5). Except the five events of the APC's, there will be another events to generate PME# event. RI1# and RI2# are Ring Indicator of Modem status at ACPI S1 or S2 state. A falling edge on these pins issues PME# events if the enable bits are set.

9.5 Environment Controller

The Environment Controller (EC), built in the IT8722F, includes eight voltage inputs, three temperature sensor inputs, three FAN Tachometer inputs, and three sets of advanced FAN Controllers. The EC monitors the hardware environment and implements environmental control for personal computers.

The IT8722F contains an 8-bit ADC (Analog-to-Digital Converter), which is responsible for monitoring the voltages and temperatures. The ADC converts the analog inputs, ranging from 0V to 4.096V, to 8-bit digital bytes. Thanks to the additional external components, the analog inputs are able to monitor different voltage ranges, in addition to monitoring the fixed input range of 0V to 4.096V. Through the external thermistors, the temperature sensor inputs can be converted to 8-bit digital bytes, enabling the sensor inputs, and monitoring the temperature around the thermistors or thermal diode. A built-in ROM is also provided to adjust the non-linear characteristics of thermistors.

FAN Tachometer inputs are digital inputs with an acceptable input range of 0V to 5V, and are responsible for measuring the FAN's Tachometer pulse periods. FAN_TAC1 and FAN_TAC2 include programmable divisors, and can be used to measure different fan speed ranges. FAN_TAC3 also includes programmable divisors, but can only be used to measure two fan speed ranges.

The EC of the IT8722F provides multiple internal registers and an interrupt generator for programmers to monitor the environment and control the FANs.

9.5.1 Interfaces

LPC Bus: The Environment Controller of the IT8722F decodes two addresses.

Table 9-1. Address Map on the LPC Bus

Registers or Ports	Address
Address register of the EC	Base+05h
Data register of the EC	Base+06h

Note 1: The Base Address is determined by the Logical Device configuration registers of the Environment Controller (LDN=04h, registers index=60h, 61h).

To access an EC register, the address of the register is written to the address port (Base+05h). Read or write data from or to that register via data port (Base+06h).

9.5.2 Registers

9.5.2.1 Address Port (Base+05h, Default=00h):

Bit	Description
7	Outstanding; Read only This bit is set when a data write is performed to Address Port. This bit can be cleared when a data write/read is performed to/from the Data Port.
6-0	Index: Internal Address of RAM and Registers.

Table 9-2. Environment Controller Registers

Index	R/W	Default	Registers or Action
00h	R/W	08h	Configuration
01h	R	00h	Interrupt Status 1
02h	R	00h	Interrupt Status 2
03h	R	00h	Interrupt Status 3
04h	R/W	00h	SMI# Mask 1
05h	R/W	00h	SMI# Mask 2
06h	R/W	00h	SMI# Mask 3
07h	R/W	00h	Interrupt Mask 1
08h	R/W	00h	Interrupt Mask 2
09h	R/W	00h	Interrupt Mask 3
0Bh	R/W	09h	Fan Tachometer Divisor Register
0Dh	R	-	Fan Tachometer 1 Reading Register
0Eh	R	-	Fan Tachometer 2 Reading Register
0Fh	R	-	Fan Tachometer 3 Reading Register
10h	R/W	-	Fan Tachometer 1 Limit Register
11h	R/W	-	Fan Tachometer 2 Limit Register
12h	R/W	-	Fan Tachometer 3 Limit Register
13h	R/W	00h	Fan Controller Main Control Register
14h	R/W	00h	FAN_CTL Control Register
15h	R/W	00h	FAN_CTL1 PWM Control Register
16h	R/W	00h	FAN_CTL2 PWM Control Register
17h	R/W	00h	FAN_CTL3 PWM Control Register
20h	R	-	VIN0 Voltage Reading Register
21h	R	-	VIN1 Voltage Reading Register
22h	R	-	VIN2 Voltage Reading Register
23h	R	-	VIN3 Voltage Reading Register
24h	R	-	VIN4 Voltage Reading Register
25h	R	-	VIN5 Voltage Reading Register
26h	R	-	VIN6 Voltage Reading Register
27h	R	-	VIN7 Voltage Reading Register
28h	R	-	VBAT Voltage Reading Register
29h	R	-	TMPIN1 Temperature Reading Register
2Ah	R	-	TMPIN2 Temperature Reading Register
2Bh	R	-	TMPIN3 Temperature Reading Register
30h	R/W	-	VIN0 High Limit Register

Table 9-2. Environment Controller Registers[cont'd]

Index	R/W	Default	Registers or Action
31h	R/W	-	VIN0 Low Limit Register
32h	R/W	-	VIN1 High Limit Register
33h	R/W	-	VIN1 Low Limit Register
34h	R/W	-	VIN2 High Limit Register
35h	R/W	-	VIN2 Low Limit Register
36h	R/W	-	VIN3 High Limit Register
37h	R/W	-	VIN3 Low Limit Register
38h	R/W	-	VIN4 High Limit Register
39h	R/W	-	VIN4 Low Limit Register
3Ah	R/W	-	VIN5 High Limit Register
3Bh	R/W	-	VIN5 Low Limit Register
3Ch	R/W	-	VIN6 High Limit Register
3Dh	R/W	-	VIN6 Low Limit Register
3Eh	R/W	-	VIN7 High Limit Register
3Fh	R/W	-	VIN7 Low Limit Register
40h	R/W	-	TMPIN1 High Limit Register
41h	R/W	-	TMPIN1 Low Limit Register
42h	R/W	-	TMPIN2 High Limit Register
43h	R/W	-	TMPIN2 Low Limit Register
44h	R/W	-	TMPIN3 High Limit Register
45h	R/W	-	TMPIN3 Low Limit Register
50h	R/W	00h	ADC Voltage Channel Enable Register
51h	R/W	00h	ADC Temperature Channel Enable Register
52h	R/W	7Fh	TMPIN1 Thermal Output Limit Register
53h	R/W	7Fh	TMPIN2 Thermal Output Limit Register
54h	R/W	7Fh	TMPIN3 Thermal Output Limit Register
58h	R	90h	ITE Vendor ID Register
59h	R/W	56h	Thermal Diode Zero Degree Adjust Register
5Ch	R/W	00h	Beep Event Enable Register
5Dh	R/W	00h	Beep Frequency Divisor of Fan Event Register
5Eh	R/W	00h	Beep Frequency Divisor of Voltage Event Register
5Fh	R/W	00h	Beep Frequency Divisor of Temperature Event Register

Table 9-3. Environment Controller Registers

Index	R/W	Default	Registers or Action
60h	R/W	00h	FAN_CTL1 SmartGuardian Automatic Mode Temperature Limit of OFF Register
61h	R/W	00h	FAN_CTL1 SmartGuardian Automatic Mode Temperature Limit of Low Speed Register
62h	R/W	00h	FAN_CTL1 SmartGuardian Automatic Mode Temperature Limit of Medium Speed Register
63h	R/W	00h	FAN_CTL1 SmartGuardian Automatic Mode Temperature Limit of High Speed Register
64h	R/W	00h	FAN_CTL1 SmartGuardian Automatic Mode Over Temperature Limit Register
65h	R/W	00h	FAN_CTL1 SmartGuardian Automatic Mode Low Speed PWM Register
66h	R/W	00h	FAN_CTL1 SmartGuardian Automatic Mode Medium Speed PWM Register
67h	R/W	00h	FAN_CTL1 SmartGuardian Automatic Mode High Speed PWM Register
68h	R/W	00h	FAN_CTL2 SmartGuardian Automatic Mode Temperature Limit of OFF Register
69h	R/W	00h	FAN_CTL2 SmartGuardian Automatic Mode Temperature Limit of Low Speed Register
6Ah	R/W	00h	FAN_CTL2 SmartGuardian Automatic Mode Temperature Limit of Medium Speed Register
6Bh	R/W	00h	FAN_CTL2 SmartGuardian Automatic Mode Temperature Limit of High Speed Register
6Ch	R/W	00h	FAN_CTL2 SmartGuardian Automatic Mode Over Temperature Limit Register
6Dh	R/W	00h	FAN_CTL2 SmartGuardian Automatic Mode Low Speed PWM Register
6Eh	R/W	00h	FAN_CTL2 SmartGuardian Automatic Mode Medium Speed PWM Register
6Fh	R/W	00h	FAN_CTL2 SmartGuardian Automatic Mode High Speed PWM Register
70h	R/W	00h	FAN_CTL3 SmartGuardian Automatic Mode Temperature Limit of OFF Register
71h	R/W	00h	FAN_CTL3 SmartGuardian Automatic Mode Temperature Limit of Low Speed Register
72h	R/W	00h	FAN_CTL3 SmartGuardian Automatic Mode Temperature Limit of Medium Speed Register
73h	R/W	00h	FAN_CTL3 SmartGuardian Automatic Mode Temperature Limit of High Speed Register
74h	R/W	00h	FAN_CTL3 SmartGuardian Automatic Mode Over Temperature Limit Register
75h	R/W	00h	FAN_CTL3 SmartGuardian Automatic Mode Low Speed PWM Register
76h	R/W	00h	FAN_CTL3 SmartGuardian Automatic Mode Medium Speed PWM Register
77h	R/W	00h	FAN_CTL3 SmartGuardian Automatic Mode High Speed PWM Register

9.5.2.2 Register Description

9.5.2.2.1 Configuration Register (Index=00h, Default=18h)

Bit	R/W	Description
7	R/W	Initialization. A "1" restores all registers to their individual default values, except the Serial Bus Address register. This bit clears itself when the default value is "0."
6	R/W	Update VBAT Voltage Reading.
5	R/W	COPEN# cleared; Write "1" to clear COPEN#.
4	R	Read Only, Always "1."
3	R/W	INT_Clear. A "1" disables the SMI# and IRQ outputs with the contents of interrupt status bits remain unchanged.
2	R/W	IRQ enables the IRQ Interrupt output.
1	R/W	SMI# Enable. A "1" enables the SMI# Interrupt output.
0	R/W	Start. A "1" enables the startup of monitoring operations while a "0" sends the monitoring operation in the STANDBY mode.

9.5.2.2.2 Interrupt Status Register 1 (Index=01h, Default=00h)

Reading this register will clear itself following a read access.

Bit	R/W	Description
7-6	R	Reserved
5	R	A "1" indicates a WTI# signal has been activated.
4	R	A "1" indicates a Case Open event has occurred.
3	R	Reserved
2-0	R	A "1" indicates the FAN_TAC3-1 Count limit has been reached.

9.5.2.2.3 Interrupt Status Register 2 (Index=02h, Default=00h)

Reading this register will clear itself after the read operation is completed.

Bit	R/W	Description
7-6	R	Reserved

Bit	R/W	Description
7-0	R	A "1" indicates a High or Low limit of VIN7-0 has been reached.

9.5.2.2.4 Interrupt Status Register 3 (Index=03h, Default=00h)

Reading this register will clear itself following a read access.

Bit	R/W	Description
7-3	R	Reserved
2-0	R	A "1" indicates a High or Low limit of Temperature 3-1 has been reached.

9.5.2.2.5 SMI# Mask Register 1 (Index=04h, Default=00h)

Bit	R/W	Description
7-6	R/W	Reserved
5	R/W	A "1" disables the WTI# Intrusion interrupt status bit for SMI#.
4	R/W	A "1" disables the Case Open Intrusion interrupt status bit for SMI#.
3	R/W	Reserved
2-0	R/W	A "1" disables the FAN_TAC3-1 interrupt status bit for SMI#.

9.5.2.2.6 SMI# Mask Register 2 (Index=05h, Default=00h)

Bit	R/W	Description
7-0	R/W	A "1" disables the VIN7-0 interrupt status bit for SMI#.

9.5.2.2.7 SMI# Mask Register 3 (Index=06h, Default=00h)

Bit	R/W	Description
7-3	R/W	Reserved
2-0	R/W	A "1" disables the Temperature 3-1 interrupt status bit for SMI#.

9.5.2.2.8 Interrupt Mask Register 1 (Index=07h, Default=00h)

Bit	R/W	Description
7-6	R/W	Reserved
5	R/W	A "1" disables the WTI# Intrusion interrupt status bit for IRQ.
4	R/W	A "1" disables the Case Open Intrusion interrupt status bit for IRQ.
3	R/W	Reserved
2-0	R/W	A "1" disables the FAN_TAC3-1 interrupt status bit for IRQ.

9.5.2.2.9 Interrupt Mask Register 2 (Index=08h, Default=00h)

Bit	R/W	Description
7-0	R/W	A "1" disables the VIN7-0 interrupt status bit for IRQ.

9.5.2.2.10 Interrupt Mask Register 3 (Index=09h, Default=00h)

Bit	R/W	Description
7-3	R/W	Reserved
2-0	R/W	A "1" disables the Temperature 3-1 interrupt status bit for IRQ.

9.5.2.2.11 Fan Tachometer Divisor Register (Index=0Bh, Default=09h)

Bit	R/W	Description
7	-	Reserved
6	R/W	FAN_TAC3 Counter Divisor 0: divided by 2 1: divided by 8
5-3	R/W	FAN_TAC2 Counter Divisor 000: divided by 1 100: divided by 16 001: divided by 2 101: divided by 32 010: divided by 4 110: divided by 64 011: divided by 8 111: divided by 128
2-0	R/W	FAN_TAC1 Counter Divisor 000: divided by 1 100: divided by 16 001: divided by 2 101: divided by 32 010: divided by 4 110: divided by 64 011: divided by 8 111: divided by 128

9.5.2.2.12 Fan Tachometer 1-3 Reading Registers (Index=0Dh-0Fh)

Bit	R/W	Description
7-0	R	The number of counts of the internal clock per revolution

9.5.2.2.13 Fan Tachometer 1-3 Limit Registers (Index=10h-12h)

Bit	R/W	Description
7-0	R	Limit value

9.5.2.2.14 Fan Controller Main Control Register (Index=13h, Default=00h)

Bit	R/W	Description
7	R	Reserved
6-4	R/W	FAN_TAC3-1 Enable
3	R/W	Reserved
2-0	R/W	FAN_CTL3-1 output mode selection. 0: ON/OFF mode. 1: SmartGuardian mode.

9.5.2.2.15 FAN_CTL Control Register (Index=14h, Default=00h)

Bit	R/W	Description
7	R	FAN_CTL Parity.
6-3	R/W	Reserved
2-0	R/W	FAN_CTL3-1 ON/OFF mode control. These bits are only available when the relative output modes are selected in ON/OFF mode. 0: OFF 1: ON

9.5.2.2.16 FAN_CTL1 PWM Control Register (Index=15h, Default=00h)

Bit	R/W	Description
7	R/W	FAN_CTL1 PWM mode Automatic/Software operation selection 0: Software Operation. 1: Automatic Operation.
6-0	R/W	128 Steps Of PWM Control When In Software Operation (Bit 7=0), Or Temperature Input Selection When In Automatic Operation (Bit 7=1). Bits [1:0]: 00: TMPIN1 01: TMPIN2 10: TMPIN3 11: Reserved

9.5.2.2.17 FAN_CTL2 PWM Control Register (Index=16h, Default=00h)

Bit	R/W	Description
7	R/W	FAN_CTL2 PWM Mode Automatic/Software Operation Selection 0: Software Operation 1: Automatic Operation
6-0	R/W	128 Steps Of PWM Control When In Software Operation (Bit 7=0), Or Temperature Input Selection When In Automatic Operation (Bit 7=1) Bits [1:0]: 00: TMPIN1 01: TMPIN2 10: TMPIN3 11: Reserved

9.5.2.2.18 FAN_CTL3 PWM Control Register (Index=17h, Default=00h)

Bit	R/W	Description
7	R/W	FAN_CTL3 PWM Mode Automatic/Software Operation Selection 0: Software Operation 1: Automatic Operation
6-0	R/W	128 Steps Of PWM Control When In Software Operation (Bit 7=0), Or Temperature Input Selection When In Automatic Operation (Bit 7=1) Bits [1:0]: 00: TMPIN1 01: TMPIN2 10: TMPIN3 11: Reserved

9.5.2.2.19 VIN7-VIN0 Voltage Reading Registers (Index=27h-20h)

Bit	R/W	Description
7-0	R/W	Voltage Reading value.

9.5.2.2.20 VBAT Voltage Reading Register (Index=28h)

Bit	R/W	Description
7-0	R/W	VBAT Voltage Reading value.

9.5.2.2.21 TMPIN3-1 Temperature Reading Registers (Index=2Bh-29h)

Bit	R/W	Description
7-0	R/W	Temperature Reading values

9.5.2.2.22 VIN7-0 High Limit Registers (Index=3Eh, 3Ch, 3Ah, 38h, 36h, 34h, 32h, 30h)

Bit	R/W	Description
7-0	R/W	High Limit Value

9.5.2.2.23 VIN7-0 Low Limit Registers (Index=3Fh, 3Dh, 3Bh, 39h, 37h, 35h, 33h, 31h)

Bit	R/W	Description
7-0	R/W	Low Limit Value

9.5.2.2.24 TMPIN3-1 High Limit Registers (Index=44h, 42h, 40h)

Bit	R/W	Description
7-0	R/W	High Limit Value

9.5.2.2.25 TMPIN3-1 Low Limit Registers (Index=45h, 43h, 41h)

Bit	R/W	Description
7-0	R/W	Low Limit Value

9.5.2.2.26 ADC Voltage Channel Enable Register (Index=50h, Default=00h)

Bit	R/W	Description
7-0	R/W	ADC VIN7-VIN0 Scan Enable

9.5.2.2.27 ADC Temperature Channel Enable Register (Index=51h, Default=00h)

TMPIN3-1 cannot be enabled in both Thermal Resistor mode and Thermal Diode (Diode connected Transistor) mode.

Bit	R/W	Description
7-6	R/W	Reserved
5-3	R/W	TMPIN3-1 are enabled in Thermal Resistor mode.
2-0	R/W	TMPIN3-1 are enabled in Thermal Diode (or Diode-connected Transistor) mode.

9.5.2.2.28 TMPIN3-1 Thermal Output Limit Registers (Index=54h-52h, Default=7Fh)

Bit	R/W	Description
7-0	R/W	Thermal Output Limit value.

9.5.2.2.29 Vendor ID Register (Index=58h, Default=90h)

Bit	R/W	Description
7-0	R	ITE Vendor ID. Read Only.

9.5.2.2.30 Thermal Diode Zero Degree Adjust Register (Index=59h, Default=56h)

This register is **read only** unless bit 7 of 5Ch is set.

Bit	R/W	Description
7-0	R/W	Thermal Diode Zero Degree Voltage value (default: 0.664V 156h).

9.5.2.2.31 Beep Event Enable Register (Index=5Ch, Default=00h)

Bit	R/W	Description
7	R/W	Thermal Diode Zero Degree Adjust register write enable.
6-3	R/W	Reserved
2	R/W	Enables Beep action when TMPINs exceed limit.
1	R/W	Enables Beep action when VINs exceed limit.
0	R/W	Enables Beep action when FAN_TACs exceed limit.

9.5.2.2.32 Beep Frequency Divisor of Fan Event Register (Index=5Dh, Default=00h)

Bit	R/W	Description
7-4	R/W	Tone divisor. $Tone = 500 / (\text{bits } [7:4] + 1)$.
3-0	R/W	Frequency divisor. $Frequency = 10K / (\text{bits } [3:0] + 1)$.

9.5.2.2.32.1 Beep Frequency Divisor of Voltage Event Register (Index=5Eh, Default=00h)

Bit	R/W	Description
7-4	R/W	Tone divisor. $Tone = 500 / (\text{bits } [7:4] + 1)$.
3-0	R/W	Frequency divisor. $Frequency = 10K / (\text{bits } [3:0] + 1)$.

9.5.2.2.33 Beep Frequency Divisor of Temperature Event Register (Index=5Fh, Default=00h)

Bit	R/W	Description
7-4	R/W	Tone divisor. $Tone = 500 / (\text{bits } [7:4] + 1)$.
3-0	R/W	Frequency divisor. $Frequency = 10K / (\text{bits } [3:0] + 1)$.

9.5.2.2.34 FAN_CTL3-1 SmartGuardian Automatic Mode Temperature Limit of OFF Registers (Index=70h, 68h, 60h, Default=7Fh)

Bit	R/W	Description
7-0	R/W	Temperature Limit value of Fan OFF.

9.5.2.2.35 FAN_CTL3-1 SmartGuardian Automatic Mode Temperature Limit of Low Speed Registers (Index=71h, 69h, 61h, Default=7Fh)

Bit	R/W	Description
7-0	R/W	Temperature Limit Value of Fan Low Speed.

9.5.2.2.36 FAN_CTL3-1 SmartGuardian Automatic Mode Temperature Limit of Medium Speed Registers (Index=72h, 6Ah, 62h, Default=7Fh)

Bit	R/W	Description
7-0	R/W	Temperature Limit Value of Fan Medium Speed.

9.5.2.2.37 FAN_CTL3-1 SmartGuardian Automatic Mode Temperature Limit of High Speed Registers (Index=73h, 6Bh, 63h, Default=7Fh)

Bit	R/W	Description
7-0	R/W	Temperature Limit Value of Fan High Speed.

9.5.2.2.38 FAN_CTL3-1 SmartGuardian Automatic Mode Over Temperature Limit Registers (Index=74h, 6Ch, 64h, Default=7Fh)

Bit	R/W	Description
7-0	R/W	Over Temperature Limit Value.

9.5.2.2.39 FAN_CTL3-1 SmartGuardian Automatic Mode Low Speed PWM Registers (Index=75h, 6Dh, 65h, Default=00h)

Bit	R/W	Description
7	R/W	Reserved
6-0	R/W	PWM Value of Low Speed.

9.5.2.2.40 FAN_CTL3-1 SmartGuardian Automatic Mode Medium Speed PWM Registers (Index=76h, 6Eh, 66h, Default=00h)

Bit	R/W	Description
7	R/W	Reserved
6-0	R/W	PWM Value of Medium Speed.

9.5.2.2.41 FAN_CTL3-1 SmartGuardian Automatic Mode High Speed PWM Registers (Index=77h, 6Fh, 67h, Default=00h)

Bit	R/W	Description
7	R/W	Reserved
6-0	R/W	PWM Value of High Speed

9.5.3 Operation
9.5.3.1 Power On RESET and Software RESET

When the system power is first applied, the EC performs a "power on reset" on the registers which are returned to default values (due to system hardware reset), and the EC will acquire a monitored value before it goes inactive. The ADC is active to monitor the VBAT pin and then goes inactive. Software reset (bit 7 of Configuration register) is able to accomplish all the functions as hardware reset does.

9.5.3.2 Starting Conversion

The monitoring function in the EC is activated when bit 3 of Configuration Register is cleared (low) and bit 0 of Configuration Register is set (high). Otherwise, several enable bits should be set to enable the monitoring function. Those enable bits are categorized into three groups: positive voltages, temperatures and FAN Tachometer inputs. Before the EC monitoring function can be used, the steps below should be followed:

1. Set the Limits
2. Set the interrupt Masks
3. Set the enable bits

Then the EC monitoring process can be started.

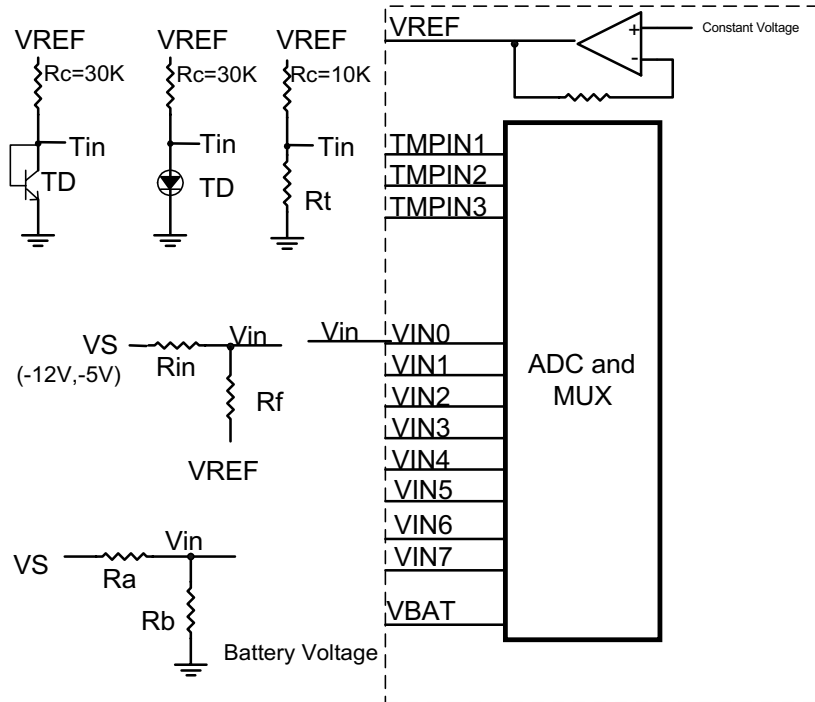

Figure 9-4. Application Example. Resistor should provide approximately 2V at the Analog Inputs.

9.5.3.3 Voltage and Temperature Inputs

The 8-bit ADC has a 16mV LSB, with a 0V to 4.096V input range. The 2.5V and 3.3V supplies of PC applications can be directly connected to the inputs. The 5V and 12V inputs should be divided into an acceptable range. When the divided circuit is used to measure the positive voltage, the recommended range for Ra and Rb is from 10KΩ to 100KΩ. The negative voltage can be measured by the same divider unless the divider is connected to VREF (constant voltage, 4.096V), not ground. The temperature measurement system of the EC converts the voltage of the TMPINs to 8-bit two's-complement. The system also includes an OP amp providing a constant voltage. It also additionally includes an external thermistor, a constant resistance, ADC and a conversion table ROM.

Temperature	Digital Output Format	
	Binary	Hex
+ 125°C	01111101	7Dh
+ 25°C	00011001	19h
+ 1°C	00000001	01h
+ 0°C	00000000	00h
- 1°C	11111111	FFh
- 25°C	11100111	E7h
- 55°C	11001001	C9h

With the addition of the external application circuit, the actual voltages are calculated as below:

Positive Voltage: $V_s = V_{in} \times (R_a + R_b) / R_b$

Negative Voltage: $V_s = (1 + R_{in}/R_f) \times V_{in} - (R_{in}/R_f) \times V_{REF}$

All the analog inputs are equipped with the internal diodes that clamp the input voltage exceeding the power supply and ground. However, the current limiting input resistor is recommended since no dividing circuit is available.

9.5.3.4 Layout and Grounding

A separate and low-impedance ground plane for analog ground is needed to achieve accurate measurement. The analog ground also provides a ground point for the voltage dividers including the temperature loops and analog components. Analog components such as voltage dividers, feedback resistors and the constant resistors of the temperature loops should be located to the IT8722F as close as possible. However, the thermistors of the temperature loops should be positioned within the measuring area. In addition, the power supply bypass, and the parallel combination of 10μF and 0.1μF bypass capacitors connected between VCC and analog ground should also be located to the IT8722F as close as possible.

Due to the small differential voltage of thermal diode (diode-connected transistor), there are many recommendations for PCB layout as below:

- Position the sensor as close as possible.
- Ground of the sensor should be directly short to GNDA with excellent noise immunity.
- Keep trace away from the noise source. (High voltage, fast data bus, fast clock , CRTs ...)
- Wider trace width (10 mil at least) and guard ground (flanking and under) are recommended.
- Position 0.1μF bypass capacitors to IT8722F as close as possible.

9.5.3.5 Fan Tachometer

The Fan Tachometer inputs gate a 22.5 kHz clock into an 8-bit counter (maximum count=255) for one period of the input signals. Several divisors, located in FAN Divisor Register, are provided for FAN_TAC1, FAN_TAC2, and FAN_TAC3, and are used to modify the monitoring range. Counts are based on 2 pulses per revolution tachometer output.

$$\text{RPM} = 1.35 \times 10^6 / (\text{Count} \times \text{Divisor})$$

The maximum input signal range is from 0 to VCC. The additional application is needed to clamp the input voltage and current.

9.5.3.6 Interrupt of the EC

The EC generates interrupts as a result of each of its Limit registers on the analog voltage, temperature, and FAN monitor. All the interrupts are indicated in two Interrupt Status Registers. The IRQ and SMI# outputs have individual mask registers. These two Interrupts can also be enabled/disabled in the Configuration Register. The Interrupt Status Registers will be reset after being read. When the Interrupt Status Registers are cleared, the Interrupt lines will also be cleared. When a read operation is completed before the completion of the monitoring loop sequence, it indicates an Interrupt Status Register has been cleared. Due to slow monitoring sequence, the EC needs 1.5 seconds to allow all the EC Registers to be safely updated between completed read operations. When the bit 3 of the Configuration Register is set to high, the Interrupt lines are cleared and the monitoring loop will be stopped. The loop will resume when this bit is cleared.

All the analog voltage inputs have high and low Limit Registers that generate Interrupts, except that the FAN monitoring inputs only have low Limit Register to warn the host. The IT8722F provides two modes dedicated to temperature interrupts in the EC: "Interrupt" mode and "Comparator" mode.

In "Interrupt" mode, an interrupt will be generated whenever the temperature exceeds Th limit, and the corresponding Interrupt status bits will be set to high until being reset by reading Interrupt Status Register 3. Once an interrupt event has occurred by crossing Th limit and then is reset afterwards, an interrupt will only occur again when the temperature goes below TL limit. Again, it will set the corresponding status bit to high until being reset by reading the Interrupt Status Register 3.

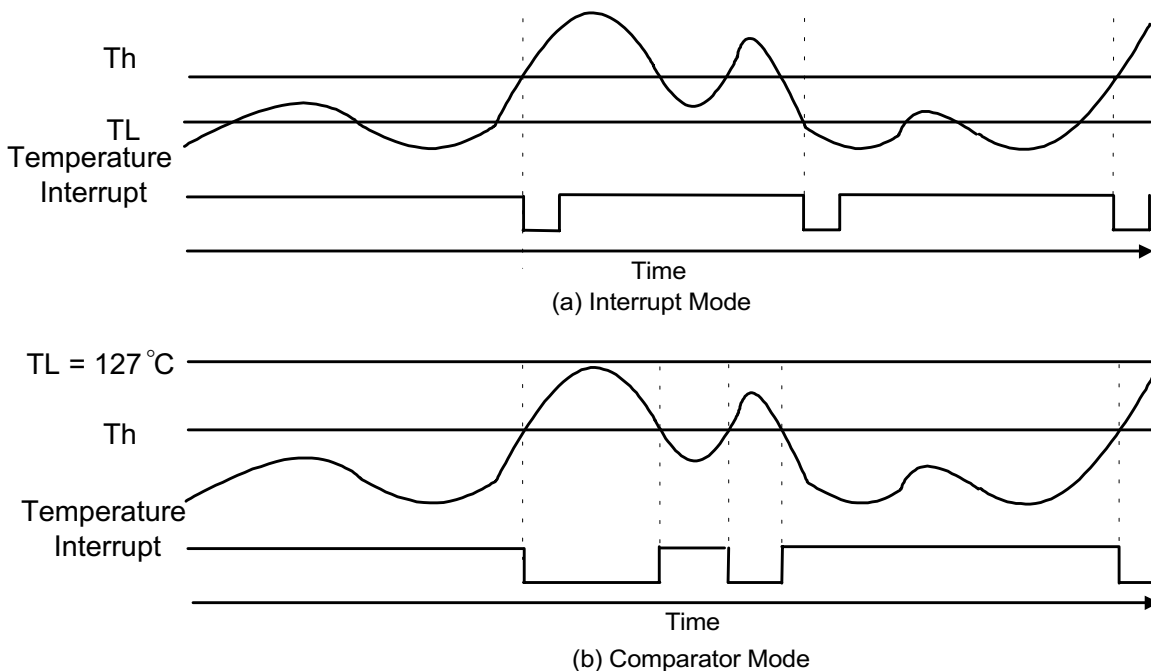

Figure 9-5. Temperature Interrupt Response Diagram

When the TL limit register is set to 127°C, the temperature interrupts enter the “**Comparator**” mode. In this mode, an interrupt will be generated whenever the temperature exceeds the Th limit. The interrupt will also be cleared by reading the Interrupt Status Register 3, but the interrupt will be set again following the completion of another measurement cycle. It will remain set until the temperature goes below the Th limit.

9.5.3.7 FAN Controller FAN_CTL’s ON-OFF and SmartGuardian Modes

The IT8722F provides an advanced FAN Controller. Two modes, ON_OFF and SmartGuardian, are provided for each controller. The former is a logical ON or OFF, and the latter is a PWM output. With the addition of external application circuits, the FAN’s voltage values can be varied easily. There are also two mode options, software and automatic, in the SmartGuardian mode. In the software mode, the PWM value is subject to the changes in the values of bits 6-0 of FAN_CTL 1-3 PWM Control Registers (Index=15h, 16h, 17h). With the application circuits, FAN_CTL can generate 128 steps of voltage. So, the FAN_CTL 1-3 PWM Control Registers can vary the voltage by changing the PWM value. Fan speeds or other voltage control-cooling device can be varied in 128 steps.

In the automatic mode, the PWM value is subject to the specific temperature inputs by five stages (OFF, Low Level, Medium Level, High Level and Full On). The PWM values of the Low, Medium and High Levels are pre-loaded. Each of FAN’s control sources (temperature inputs) can be any of the three temperature inputs, and are determined by bits 1-0 of FAN_CTL PWM Control Registers (Index=15h, 16h, 17h). When the source temperature is below the Low Temperature (Index=71h, 69h, 61h), the FAN_CTL output will enter the OFF state. When the temperature is between Low and Medium (Index=72h, 6Ah, 62h), the output will perform Low Level PWM; Medium Level PWM when between Medium and High (Index=73h, 6Bh, 63h); High Level PWM when between High and Over (Index=74h, 6Ch, 64h). When any of the Over Temperatures is exceeded, all the FAN_CTL outputs will be full ON. The FAN_CTL output will not return to the OFF state until the source temperature goes below the OFF Temperature limit (Index=70h, 68h, 60h).

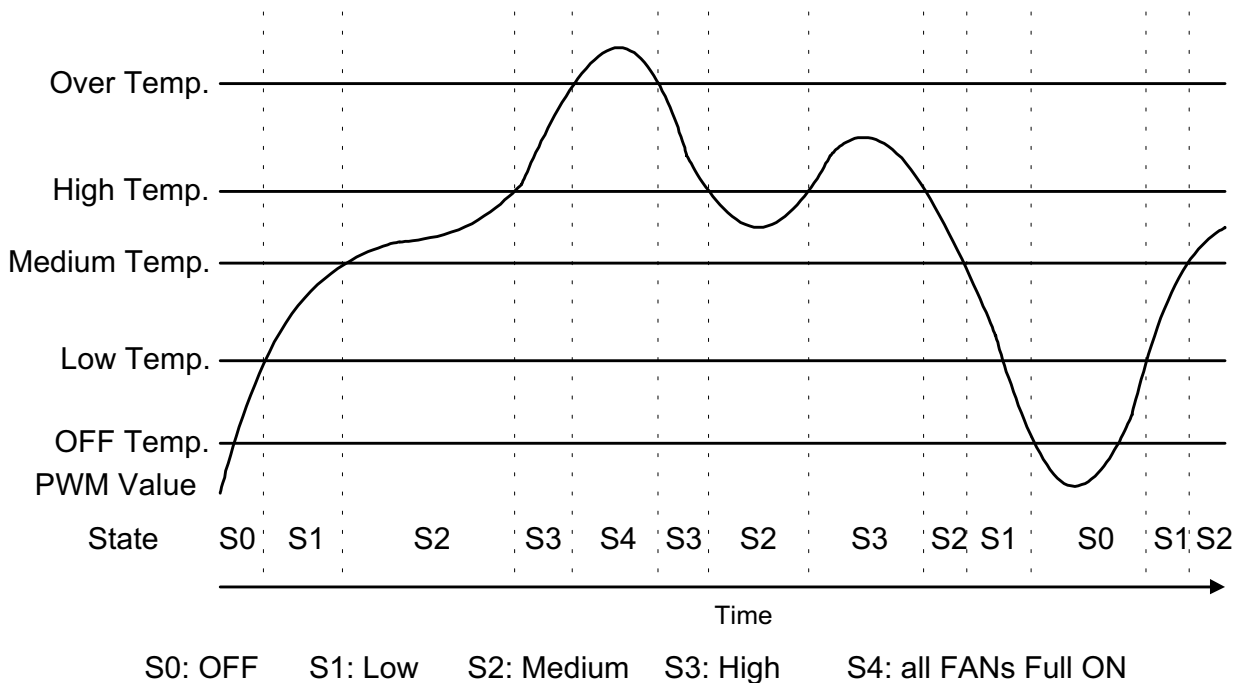

Figure 9-6. SmartGuardian Automatic Mode

9.6 Floppy Disk Controller (FDC)

9.6.1 Introduction

The Floppy Disk Controller provides the interface between a host processor and up to two floppy disk drives. It integrates a controller and a digital data separator with write precompensation, data rate selection logic, microprocessor interface, and a set of registers.

The FDC supports data transfer rates of 250 Kbps, 300 Kbps, 500 Kbps, and 1 Mbps. It operates in PC/AT mode and supports 3-mode type drives. Additionally, the FDC is software compatible with the 82077.

The FDC configuration is handled by software and a set of Configuration registers. Status, Data, and Control registers facilitate the interface between the host microprocessor and the disk drive, providing information about the condition and/or state of the FDC. These configuration registers can select the data rate, enable interrupts, drives, and DMA modes, and indicate errors in the data or operation of the FDC/FDD.

The controller manages data transfers using a set of data transfer and control commands. These commands are handled in three phases: Command, Execution, and Result. Not all commands utilize all these three phases.

9.6.2 Reset

The IT8722F device implements both software and hardware reset options for the FDC. Either type of the resets will reset the FDC, terminate all operations and place the FDC into an idle state. A reset during a write to the disk will corrupt the data and the corresponding CRC.

9.6.3 Hardware Reset (LRESET# Pin)

When the FDC receives a LRESET# signal, all registers of the FDC core are cleared (except those programmed by the SPECIFY command). To exit the reset state, the host must clear the DOR bit.

9.6.4 Software Reset (DOR Reset and DSR Reset)

When the reset bit in the DOR or DSR is set, all registers of the FDC core are cleared. A reset performed by setting the reset bit in the DOR has higher priority over a reset performed by setting the reset bit in the DSR. In addition, to exit the reset state, the DSR bit is self-clearing, while the host must clear the DOR bit.

9.6.5 Digital Data Separator

The internal digital data separator is comprised of a digital PLL and associated support circuitry. It is responsible for synchronizing the raw data signal read from the floppy disk drive. The synchronized signal is used to separate the encoded clock from the data pulses.

9.6.6 Write Precompensation

Write precompensation is a method that can be used to adjust the effects of bit shift on data as it is written to the disk. It is harder for the data separator to read data that has been subject to bit shifting. Soft read errors can occur due to such bit shifting. Write precompensation predicts where the bit shifting might occur within a data pattern and shifts the individual data bits back to their nominal positions.

The FDC permits the selection of writes precompensation via the Data Rate Select Register (DSR) bits 2 through 4.

9.6.7 Data Rate Selection

Selecting one of the four possible data rates for the attached floppy disks is accomplished by setting the Diskette Control Register (DCR) or Data Rate Select Register (DSR) bits to 0 and 1. The data rate is determined by the last value that is written to either the DCR or the DSR. When the data rate is set, the data separator clock is scaled appropriately.

9.6.8 Status, Data and Control Registers

9.6.8.1 Digital Output Register (DOR, FDC Base Address + 02h)

This is a **read/write** register. It controls drive selection and motor enables as well as a software reset bit and DMA enable. The I/O interface reset may be used at any time to clear the DOR's contents.

Table 9-4. Digital Output Register (DOR)

Bit	Symbol	Description
7-6	-	Reserved
5	MOTBE N	Drive B Motor Enable 0: Disable Drive B motor. 1: Enable Drive B motor.
4	MOTAE N	Drive A Motor Enable 0: Disable Drive A motor. 1: Enable Drive A motor.
3	DMAEN	Disk Interrupt and DMA Enable 0: Disable disk interrupt and DMA (DRQx, DACKx#, TC and INTx). 1: Enable disk interrupt and DMA.
2	RESET#	FDC Function Reset 0: Reset FDC function. 1: Clear reset of FDC function. This reset does not affect the DSR, DCR or DOR.
1	-	Reserved
0	DVSEL	Drive Selection 0: Select Drive A. 1: Select Drive B.

9.6.8.2 Tape Drive Register (TDR, FDC Base Address + 03h)

This is a **read/write** register and is included for 82077 software compatibility. The contents of this register are not used internal to the device.

Table 9-5. Tape Drive Register (TDR)

Bit	Symbol	Description
7-2	-	Undefined
1-0	TP_SEL [1:0]	Tape Drive Selection TP_SEL [1:0] : Drive selected 00: None 01: 1 10: 2 11: 3

9.6.8.3 Main Status Register (MSR, FDC Base Address + 04h)

This is a **read only** register. It indicates the general status of the FDC, and is able to receive data from the host. The MSR should be read before each byte is sent to or received from the Data register, except when it is in the DMA mode.

Table 9-6. Main Status Register (MSR)

Bit	Symbol	Description
7	RQM	Request for Master FDC Request for Master. 0: The FDC is busy and cannot receive data from the host. 1: The FDC is ready and the host can transfer data.
6	DIO	Data I/O Direction Indicates the direction of data transfer once a RQM has been set. 0: Write. 1: Read.
5	NDM	Non-DMA Mode This bit selects Non-DMA mode of operation. 0: DMA mode selected. 1: Non-DMA mode selected. This mode is selected via the SPECIFY command during the Execution phase of a command.
4	CB	Diskette Control Busy Indicates whether a command is in progress (the FDD is busy). 0: A command has been executed and the end of the Result phase has been reached. 1: A command is being executed.
3-2	-	Reserved
1	DBB	Drive B Busy Indicates whether Drive B is in the SEEK portion of a command. 0: Not busy. 1: Busy.
0	DAB	Drive A Busy Indicates whether Drive A is in the SEEK portion of a command. 0: Not busy. 1: Busy.

9.6.8.4 Data Rate Select Register (DSR, FDC Base Address + 04h)

This is a **write only** register. It is used to determine the data rate, amount of write precompensation, power down mode, and software reset. The data rate of the floppy disk controller is the most recent write of either the DSR or DCR. The DSR is unaffected by software reset. The DSR can be set to 02h by hardware reset. The “02h” represents the default precompensation, and 250 Kbps indicates the data transfer rate.

Table 9-7. Data Rate Select Register (DSR)

Bit	Symbol	Description																												
7	S/W RESET	Software Reset Software Reset. It is active high and shares the same function with the RESET# of the DOR except that this bit is self-clearing.																												
6	POWER DOWN	Power Down When this bit is written “1”, the floppy controller is put into the manual low power mode. The clocks of the floppy controller and data separator circuits will be turned off until software reset, Data Register or Main Status Register is accessed.																												
5	-	Undefined																												
4-2	PRE- COMP 2-0	<p>Precompensation Select These three bits are used to determine the value of write precompensation that will be applied to the WDATA# pin. Track 0 is the default starting track number, which can be changed by the CONFIGURE command for precompensation.</p> <table border="1" data-bbox="488 888 1027 1276"> <thead> <tr> <th>PRE_COMP</th> <th>Precompensation Delay</th> </tr> </thead> <tbody> <tr><td>111</td><td>0.0 ns</td></tr> <tr><td>001</td><td>41.7 ns</td></tr> <tr><td>010</td><td>83.3 ns</td></tr> <tr><td>011</td><td>125.0 ns</td></tr> <tr><td>100</td><td>166.7 ns</td></tr> <tr><td>101</td><td>208.3 ns</td></tr> <tr><td>110</td><td>250.0 ns</td></tr> <tr><td>000</td><td>Default</td></tr> </tbody> </table> <p style="text-align: center;">Default Precompensation Delays</p> <table border="1" data-bbox="488 1346 1027 1564"> <thead> <tr> <th>Data Rate</th> <th>Precompensation Delay</th> </tr> </thead> <tbody> <tr><td>1 Mbps</td><td>41.7 ns</td></tr> <tr><td>500 Kbps</td><td>125.0 ns</td></tr> <tr><td>300 Kbps</td><td>125.0 ns</td></tr> <tr><td>250 Kbps</td><td>125.0 ns</td></tr> </tbody> </table>	PRE_COMP	Precompensation Delay	111	0.0 ns	001	41.7 ns	010	83.3 ns	011	125.0 ns	100	166.7 ns	101	208.3 ns	110	250.0 ns	000	Default	Data Rate	Precompensation Delay	1 Mbps	41.7 ns	500 Kbps	125.0 ns	300 Kbps	125.0 ns	250 Kbps	125.0 ns
PRE_COMP	Precompensation Delay																													
111	0.0 ns																													
001	41.7 ns																													
010	83.3 ns																													
011	125.0 ns																													
100	166.7 ns																													
101	208.3 ns																													
110	250.0 ns																													
000	Default																													
Data Rate	Precompensation Delay																													
1 Mbps	41.7 ns																													
500 Kbps	125.0 ns																													
300 Kbps	125.0 ns																													
250 Kbps	125.0 ns																													
1-0	DRATE1-0	<p>Data Rate Select</p> <table data-bbox="570 1661 1023 1812"> <thead> <tr> <th>Bits 1-0</th> <th>Data Transfer Rate</th> </tr> </thead> <tbody> <tr><td>00</td><td>500 Kbps</td></tr> <tr><td>01</td><td>300 Kbps</td></tr> <tr><td>10</td><td>250 Kbps (default)</td></tr> <tr><td>11</td><td>1 Mbps</td></tr> </tbody> </table>	Bits 1-0	Data Transfer Rate	00	500 Kbps	01	300 Kbps	10	250 Kbps (default)	11	1 Mbps																		
Bits 1-0	Data Transfer Rate																													
00	500 Kbps																													
01	300 Kbps																													
10	250 Kbps (default)																													
11	1 Mbps																													

9.6.8.5 Data Register (FIFO, FDC Base Address + 05h)

This is an 8-bit **read/write** register. It transfers command information, diskette drive status information, and the result phase status between the host and the FDC. The FIFO consists of several registers in a stack. Only one register in the stack is permitted to transfer information or status to the data bus at a time.

Table 9-8. Data Register (FIFO)

Bit	Symbol	Description
7-0		Data Command information, diskette drive status, or result phase status data

9.6.8.6 Digital Input Register (DIR, FDC Base Address + 07h)

This is a **read only** register and it shares this address with the Diskette Control Register (DCR).

Table 9-9. Digital Input Register (DIR)

Bit	Symbol	Description
7	DSKCHG	Diskette Change Indicates the inverting value of the bit monitored from the input of the Floppy Disk Change pin (DSKCHG#).
6-0	-	Undefined

9.6.8.7 Diskette Control Register (DCR, FDC Base Address + 07h)

This is a **write only** register and it shares this address with the Digital Input Register (DIR). The DCR register controls the data transfer rate for the FDC.

Table 9-10. Diskette Control Register (DCR)

Bit	Symbol	Description										
7-2	-	Reserved. Always 0										
1-0	DRATE1-0	Data Rate Select <table style="margin-left: 40px;"> <thead> <tr> <th>Bits 1-0</th> <th>Data Transfer Rate</th> </tr> </thead> <tbody> <tr> <td>00</td> <td>500 Kbps</td> </tr> <tr> <td>01</td> <td>300 Kbps</td> </tr> <tr> <td>10</td> <td>250 Kbps</td> </tr> <tr> <td>11</td> <td>1 Mbps</td> </tr> </tbody> </table>	Bits 1-0	Data Transfer Rate	00	500 Kbps	01	300 Kbps	10	250 Kbps	11	1 Mbps
Bits 1-0	Data Transfer Rate											
00	500 Kbps											
01	300 Kbps											
10	250 Kbps											
11	1 Mbps											

9.6.9 Controller Phases

The FDC handles data transfers and control commands in three phases, Command, Execution and Result. Not all commands utilize these three phases.

9.6.9.1 Command Phase

Upon reset, the FDC enters the Command phase and is ready to receive commands from the host. The host must verify that MSR bit 7 (RQM) = 1 and MSR bit 6 (DIO) = 0, indicating the FDC is ready to receive data. For each command, a defined set of command code and parameter bytes must be transferred to the FDC in a given order. See sections 11.6.11 and 11.6.12 for details on the various commands. RQM is set false (0) after each byte-Read cycle, and set true (1) when a new parameter byte is required. The Command phase is completed when this set of bytes has been received by the FDC. The FDC automatically enters the next

controller phase and the FIFO is disabled.

9.6.9.2 Execution Phase

Upon the completion of the Command phase, the FDC enters the Execution phase. It is in this phase that all data transfers occur between the host and the FDC. The SPECIFY command indicates whether this data transfer occurs in the DMA or non-DMA mode. Each data byte is transferred via an IRQx or DRQx# based upon the DMA mode. On reset, the CONFIGURE command can automatically enable or disable the FIFO. The Execution phase is completed when all data bytes have been received. If the command executed does not require a Result phase, the FDC is ready to receive the next command.

9.6.9.3 Result Phase

For commands that require data written to the FIFO, the FDC enters the Result phase when the IRQ or DRQ is activated. The MSR bit 7 (RQM) and MSR bit 6 (DIO) must equal 1 to read the data bytes. The Result phase is completed when the host has read each of the defined set of result bytes for the given command. Right after the completion of the phase, RQM is set to 1, DIO is set to 0, and the MSR bit 4 (CB) is cleared, indicating the FDC is ready to receive the next command.

9.6.9.4 Result Phase Status Registers

For commands that contain a Result phase, these **read only** registers indicate the status of the most recently executed command.

Table 9-11. Status Register 0 (ST0)

Bit	Symbol	Description
7-6	IC	Interrupt Code 00: Execution of the command has been completed correctly. 01: Execution of the command began, but failed to complete successfully. 10: INVALID command. 11: Execution of the command was not completed correctly due to a polling error.
5	SE	Seek End The FDC executed a SEEK or RE-CALIBRATE command.
4	EC	Equipment Check The TRK0# pin was not set after a RE-CALIBRATE command was issued.
3	NU	Not Used
2	H	Head Address The current head address.
1	DSB	Drive B Select Drive B selected.
0	DSA	Drive A Select Drive A selected.

Table 9-12. Status Register 1 (ST1)

Bit	Symbol	Description
7	EN	End of Cylinder Indicates the FDC attempted to access a sector beyond the final sector of the track. This bit will be set if the Terminal Count (TC) signal is not issued after a READ DATA or WRITE DATA command.
6	NU	Not Used
5	DE	Data Error A CRC error occurred in either the ID field or the data field of a sector.
4	OR	Overrun/ Underrun An overrun on a READ operation or underrun on a WRITE operation occurs when the FDC is not serviced by the CPU or DMA within the required time interval.
3	NU	Not Used
2	ND	No Data No data are available for the FDC when either of the following conditions is met: <ol style="list-style-type: none"> 1. The floppy disk cannot find the indicated sector while the READ DATA or READ DELETED DATA commands are executed 2. While executing a READ ID command, an error occurs upon reading the ID field 3. While executing a READ A TRACK command, the FDC cannot find the starting sector
1	NW	Not Writeable Set when a WRITE DATA, WRITE DELETED DATA, or FORMAT A TRACK command is being executed on a write-protected diskette.
0	MA	Missing Address Mark This flag bit is set when either of the following conditions is met: <ol style="list-style-type: none"> 1. The FDC cannot find a Data Address Mark or a Deleted Data Address Mark on the specified track 2. The FDC cannot find any ID address on the specified track after two index pulses are detected from the INDEX# pin

Table 9-13. Status Register 2 (ST2)

Bit	Symbol	Description
7	NU	Not Used
6	CM	Control Mark This flag bit is set when either of the following conditions is met: The FDC finds a Deleted Data Address Mark during a READ DATA command The FDC finds a Data Address Mark during a READ DELETED DATA command
5	DD	Data Error in Data Field This flag bit is set when a CRC error is found in the data field.
4	WC	Wrong Cylinder This flag bit is set when the track address in the ID field is different from the track address specified in the FDC.
3	SH	Scan Equal Hit This flag bit is set when the condition of "equal" is satisfied during a SCAN command.
2	SN	Scan Not Satisfied This flag bit is set when the FDC cannot find a sector on the cylinder during a SCAN command.
1	BC	Bad Cylinder This flag bit is set when the track address equals "FFh" and is different from the track address in the FDC.
0	MD	Missing Data Address Mark This flag bit is set when the FDC cannot find a Data Address Mark or Deleted Data Address Mark.

Table 9-14. Status Register 3 (ST3)

Bit	Symbol	Description
7	FT	Fault Indicates the current status of the Fault signal from the FDD.
6	WP	Write Protect Indicates the current status of the Write Protect signal from the FDD.
5	RDY	Ready Indicates the current status of the Ready signal from the FDD.
4	TK0	Track 0 Indicates the current status of the Track 0 signal from the FDD.
3	TS	Two Side Indicates the current status of the Two Side signal from the FDD.
2	HD	Head Address Indicates the current status of the Head Select signal to the FDD.
1-0	US1, US0	Unit Select Indicates the current status of the Unit Select signals to the FDD.

9.6.10 Command Set

The FDC utilizes a defined set of commands to communicate with the host. Each command is comprised of the unique first byte, which contains the op-code and a series of additional bytes, which contain the required set of parameters and results. The descriptions use a common set of parameter byte symbols, which are presented in Table 10-14. The FDC commands may be executed whenever the FDC is in the Command phase. The FDC checks to see whether the first byte is a valid command. Proceed if it is not a valid command. On the contrary, an interrupt is issued if it is not a valid command.

Table 9-15. Command Set Symbol Descriptions

Symbol	Description
C	Cylinder Number The current/selected cylinder (track) number: 0 – 255.
D	Data The data pattern to be written into a sector.
DC3–DC0	Drive Configuration Bit3-0 Designate which drives are perpendicular drives on the PERPENDICULAR MODE command.
DIR	Direction Control Read/Write Head Step Direction Control. 0 = Step Out; 1 = Step In.
DR0, DR1	Disk Drive Select The selected drive number: 0 or 1.
DTL	Data Length When N is defined as 00h, DTL designates the number of data bytes which users are going to read out or write into the Sector. When N is not 00h, DTL is undefined.
DFIFO	Disable FIFO A “1” will disable the FIFO (default). A “0” will enable the FIFO.
EC	Enable Count If EC=1, DTL of VERIFY command will be SC.
EIS	Enable Implied Seek If EIS=1, a SEEK operation will be performed before executing any READ or WRITE command that requires the C parameter.
EOT	End of Track The final sector number on a cylinder. During a READ or WRITE operation, the FDC stops data transfer after the sector number is equal to EOT.
GAP2	Gap 2 Length By PERPENDICULAR MODE command, this parameter changes the length of Gap 2 in the format.
GPL	Gap Length The length of Gap 3. During a FORMAT command, it determines the size of Gap 3.
H	Head Address The Head number 0 or 1, as specified in the sector ID field. (H = HD in all command words.)
HD	Head The selected Head number 0 or 1. Also controls the polarity of HDSEL#. (H = HD in all command words.)
HLT	Head Load Time The Head Load Time in the FDD (2 to 254 ms in 2 ms increments).
HUT	Head Unload Time The Head Unload Time after a READ or WRITE operation has been executed (16 to 240 ms in 16 ms increments).
LOCK	If LOCK=1, DFIFO, FIFOTHR and PRETRK parameters of the CONFIGURE command will not be affected by software reset. If LOCK=0 (default), the above parameters will be set to their default values following software reset.
MFM	FM or MFM Mode If MFM is low, FM Mode (single density) is selected. If MFM is high, MFM Mode (double density) is selected.
MT	Multi-Track If MT is high, a Multi-Track operation is to be performed. In this mode, the FDC will automatically start searching for sector 1 on side 1 after finishing a READ/WRITE operation on the last sector on side 0.

Table 9-14. Command Set Symbol Descriptions [cont'd]

Symbol	Description
N	Number The number of data bytes written into a sector, where: 00 = 128 bytes (PC standard) 01 = 256 bytes 02 = 512 bytes ... 07 = 16 Kbytes
NCN	New Cylinder Number A new cylinder number, which is to be reached as a result of the SEEK operation. Desired position of Head.
ND	Non-DMA Mode When ND is high, the FDC operates in the Non-DMA Mode.
OW	Overwrite If OW=1, DC3-0 of the PERPENDICULAR MODE command can be modified. Otherwise, those bits cannot be changed.
PCN	Present Cylinder Number The current cylinder number of the head at the completion of a SENSE INTERRUPT STATUS command.
POLL	Polling Disable If POLL=1, the internal polling routine is disabled.
PRETRK	Precompensation Starting Track Number Programmable from track 0 –255.
R	Record The sector number, which will be read or written.
RCN	Relative Cylinder Number To determine the relative cylinder offset from the present cylinder as used by the RELATIVE SEEK command.
SC	The number of sectors per cylinder.
SK	Skip If SK=1, the Read Data operation will skip sectors with a Deleted Data Address Mark. Otherwise, the Read Deleted Data operation only accesses sectors with a Deleted Data Address Mark.
SRT	Step Rate Time The Stepping Rate for the FDD (1 to 16 ms in 1 ms increments). Stepping Rate applies to all drives (F=1 ms, E=2 ms, etc.).
ST0 ST1 ST2 ST3	Status 0–3 ST0–3 stand for one of four registers that store the status information after a command has been executed. This information is available during the Result phase after command execution. These registers should not be confused with the Main Status Register (selected by A ₀ = 0). ST0–3 may be read only after a command has been executed and contain information associated with that particular command.
STP	If STP = 1 during a SCAN operation, the data in contiguous sectors are compared byte by byte with data sent from the processor (or DMA). If STP = 2, alternate sectors are read and compared.

Table 9-16. Command Set Summary

READ DATA			
Phase	R/W	Data Bus	Remarks

		D7	D6	D5	D4	D3	D2	D1	D0	
Command	W	MT	MFM	SK	0	0	1	1	0	Command Codes
	W	0	0	0	0	0	HDS	DR1	DR0	
	W	C								Sector ID information before the command execution
	W	H								
	W	R								
	W	N								
	W	EOT								
	W	GPL								
	W	DTL								
Execution										
Result	R	ST0								Status information after command execution
	R	ST1								
	R	ST2								
	R	C								Sector ID information after command execution
	R	H								
	R	R								
	R	N								

READ DELETED DATA										
Phase	R/W	Data Bus								Remarks
		D7	D6	D5	D4	D3	D2	D1	D0	
Command	W	MT	MFM	SK	0	1	1	0	0	Command Codes
	W	0	0	0	0	0	HDS	DR1	DR0	
	W	C								Sector ID information before the command execution
	W	H								
	W	R								
	W	N								
	W	EOT								
	W	GPL								
	W	DTL								
Execution										
Result	R	ST0								Status information after command execution
	R	ST1								
	R	ST2								
	R	C								Sector ID information after command execution
	R	H								
	R	R								
	R	N								

READ A TRACK										
Phase	R/W	Data Bus								Remarks
		D7	D6	D5	D4	D3	D2	D1	D0	
Command	W	MT	MFM	0	0	0	0	1	0	Command Codes
	W	0	0	0	0	0	HDS	DR1	DR0	
	W	C								Sector ID information before the command execution
	W	H								
	W	R								
	W	N								
	W	EOT								
	W	GPL								
	W	DTL								
Execution										Data transfer between the FDD and main system cylinder's contents from index hole to EOT
Result	R	ST0								Sector ID information before the command execution
	R	ST1								
	R	ST2								
	R	C								Sector ID information after command execution
	R	H								
	R	R								
	R	N								

WRITE DATA										
Phase	R/W	Data Bus								Remarks
		D7	D6	D5	D4	D3	D2	D1	D0	
Command	W	MT	MFM	0	0	0	1	0	1	Command Codes
	W	0	0	0	0	0	HDS	DR1	DR0	
	W	C								Sector ID information before the command execution
	W	H								
	W	R								
	W	N								
	W	EOT								
	W	GPL								
	W	DTL								
Execution										
Result	R	ST0								Status information after command execution
	R	ST1								
	R	ST2								
	R	C								Sector ID information after command execution
	R	H								
	R	R								
	R	N								

WRITE DELETED DATA										
Phase	R/W	Data Bus								Remarks
		D7	D6	D5	D4	D3	D2	D1	D0	
Command	W	MT	MFM	0	0	1	0	0	1	Command Codes
	W	0	0	0	0	0	HDS	DR1	DR0	
	W	C								Sector ID information before the command execution
	W	H								
	W	R								
	W	N								
	W	EOT								
	W	GPL								
	W	DTL								
Execution										
Result	R	ST0								Status information after command execution
	R	ST1								
	R	ST2								
	R	C								Sector ID information after command execution
	R	H								
	R	R								
	R	N								

FORMAT A TRACK										
Phase	R/W	Data Bus								Remarks
		D7	D6	D5	D4	D3	D2	D1	D0	
Command	W	0	MFM	0	0	1	1	0	1	Command Codes
	W	0	0	0	0	0	HDS	DR1	DR0	
	W	N								Bytes/Sector
	W	SC								Sectors/Cylinder
	W	GPL								Gap 3
	W	D								Filler Byte
Execution	W	C								Input Sector Parameters per-sector
	W	H								
	W	R								
	W	N								
Result	R	ST0								FDC formats an entire cylinder Status information after command execution
	R	ST1								
	R	ST2								
	R	Undefined								
	R	Undefined								
	R	Undefined								
	R	Undefined								

SCAN EQUAL										
Phase	R/W	Data Bus								Remarks
		D7	D6	D5	D4	D3	D2	D1	D0	
Command	W	MT	MFM	SK	1	0	0	0	1	Command Codes
	W	0	0	0	0	0	HDS	DR1	DR0	
	W	C								Sector ID information before the command execution
	W	H								
	W	R								
	W	N								
	W	EOT								
	W	GPL								
	W	DTL								
Execution										Data transferred from the system to controller is compared to data read from disk
Result	R	ST0								Status information after command execution
	R	ST1								
	R	ST2								
	R	C								Sector ID information after command execution
	R	H								
	R	R								
	R	N								

SCAN LOW OR EQUAL										
Phase	R/W	Data Bus								Remarks
		D7	D6	D5	D4	D3	D2	D1	D0	
Command	W	MT	MFM	SK	1	1	0	0	1	Command Codes
	W	0	0	0	0	0	HDS	DR1	DR0	
	W	C								Sector ID information before the command execution
	W	H								
	W	R								
	W	N								
	W	EOT								
	W	GPL								
	W	DTL								
Execution										
Result	R	ST0								Status information after command execution
	R	ST1								
	R	ST2								
	R	C								Sector ID information after command execution
	R	H								
	R	R								
	R	N								

SCAN HIGH OR EQUAL										
Phase	R/W	Data Bus								Remarks
		D7	D6	D5	D4	D3	D2	D1	D0	
Command	W	MT	MFM	SK	1	1	1	0	1	Command Codes
	W	0	0	0	0	0	HDS	DR1	DR0	
	W	C								Sector ID information before the command execution
	W	H								
	W	R								
	W	N								
	W	EOT								
	W	GPL								
	W	DTL								
Execution										Data transferred from the system to controller is compared to data read from disk
Result	R	ST0								Status information after command execution
	R	ST1								
	R	ST2								
	R	C								Sector ID information after command execution
	R	H								
	R	R								
	R	N								

VERIFY										
Phase	R/W	Data Bus								Remarks
		D7	D6	D5	D4	D3	D2	D1	D0	
Command	W	MT	MFM	SK	1	0	1	1	0	Command Codes
	W	EC	0	0	0	0	HDS	DR1	DR0	
	W	C								Sector ID information before the command execution
	W	H								
	W	R								
	W	N								
	W	EOT								
	W	GPL								
	W	DTL/SC								
Execution										
	R	ST1								Sector ID information after command execution
	R	ST2								
	R	C								
	R	H								
	R	R								
	R	N								

READ ID										
Phase	R/W	Data Bus								Remarks
		D7	D6	D5	D4	D3	D2	D1	D0	
Command	W	0	MFM	0	0	1	0	1	0	Command Codes
	W	0	0	0	0	0	HDS	DR1	DR0	
Execution										The first correct ID information on the Cylinder is stored in the Data Register
Sector ID information during execution phase	R	ST0								Status information after command execution
	R	ST1								
	R	ST2								
	R	C								
	R	H								
	R	R								
	R	N								

CONFIGURE

Phase	R/W	Data Bus								Remarks
		D7	D6	D5	D4	D3	D2	D1	D0	
Command	W	0	0	0	1	0	0	1	1	Configure Information
	W	0	0	0	0	0	0	0	0	
	W	0	EIS	DFIFO	POLL D	FIFOTHR				
		PRETRK								
Execution										

RE-CALIBRATE										
Phase	R/W	Data Bus								Remarks
		D7	D6	D5	D4	D3	D2	D1	D0	
Command	W	0	0	0	0	0	1	1	1	Command Codes
	W	0	0	0	0	0	0	DR1	DR0	
Execution										Head retracted to Track 0

SEEK										
Phase	R/W	Data Bus								Remarks
		D7	D6	D5	D4	D3	D2	D1	D0	
Command	W	0	0	0	0	1	1	1	1	Command Codes
	W	0	0	0	0	0	HDS	DR1	DR0	
	W	NCN								
Execution										Head is positioned over proper cylinder on diskette

RELATIVE SEEK										
Phase	R/W	Data Bus								Remarks
		D7	D6	D5	D4	D3	D2	D1	D0	
Command	W	1	DIR	0	0	1	1	1	1	Command Codes
	W	0	0	0	0	0	HDS	DR1	DR0	
	W	RCN								
Execution										Head is stepped in or out a programmable number of tracks

DUMPREG										
Phase	R/W	Data Bus								Remarks
		D7	D6	D5	D4	D3	D2	D1	D0	
Command	W	0	0	0	0	1	1	1	0	Command Codes
Execution										Registers placed in FIFO
Result	R	PCN-Drive 0								
	R	PCN-Drive 1								
	R	PCN-Drive 2								
	R	PCN-Drive 3								
	R	SRT				HUT				
	R	HLT								ND
	R									
	R	LOCK	0	DC3	DC2	DC1	DC0	GAP	WG	
	R	0	DIS	DFIFO	POLL D	FIFOTHR				
	R	PRETRK								

LOCK										
Phase	R/W	Data Bus								Remarks
		D7	D6	D5	D4	D3	D2	D1	D0	
Command	W	LOCK	0	0	1	0	1	0	0	Command Codes
Result	R	0	0	0	LOCK	0	0	0	0	

VERSION										
Phase	R/W	Data Bus								Remarks
		D7	D6	D5	D4	D3	D2	D1	D0	
Command	W	0	0	0	1	0	0	0	0	Command Codes
Result	R	1	0	0	1	0	0	0	0	Enhanced Controller

SENSE INTERRUPT STATUS											
Phase	R/W	Data Bus								Remarks	
		D7	D6	D5	D4	D3	D2	D1	D0		
Command	W	0	0	0	0	1	0	0	0	Command Codes	
Result	R	ST0									Status information at the end of each SEEK operation
	R	PCN									

SENSE DRIVE STATUS										
Phase	R/W	Data Bus								Remarks
		D7	D6	D5	D4	D3	D2	D1	D0	
Command	W	0	0	0	0	0	1	0	0	Command Codes
	W	0	0	0	0	0	HDS	DR1	DR0	
Result	R	ST3								Status information about FDD

SPECIFY										
Phase	R/W	Data Bus								Remarks
		D7	D6	D5	D4	D3	D2	D1	D0	
Command	W	0	0	0	0	0	0	1	1	Command Codes
	W	SRT				HUT				
	W	HLT							ND	

PERPENDICULAR MODE										
Phase	R/W	Data Bus								Remarks
		D7	D6	D5	D4	D3	D2	D1	D0	
Command	W	0	0	0	1	0	0	1	0	Command Codes
	W	OW	0	DC3	DC2	DC1	DC0	GAP	WG	

INVALID										
Phase	R/W	Data Bus								Remarks
		D7	D6	D5	D4	D3	D2	D1	D0	
Command	W	Invalid codes								INVALID Command Codes (NO-OP: FDC goes into a standby state)
Result	R	ST0								ST0 = 80h

9.6.11 Data Transfer Commands

All data transfer commands utilize the same parameter bytes (except for FORMAT A TRACK command) and return the same result data bytes. The only difference between them is the five bits (bit 0–bit 4) of the first byte.

9.6.11.1 Read Data

The READ DATA command contains nine command bytes that place the FDC into the Read Data mode. Each READ operation is initialized by a READ DATA command. The FDC locates the sector to be read by matching ID Address Marks and ID fields from the command with the information on the diskette. The FDC then transfers the data to the FIFO. When the data from the given sector have been read, the READ DATA command is completed and the sector address is automatically incremented by 1. The data from the next sector are read and transferred to the FIFO in the same manner. Such a continuous read function is called a "Multi-Sector Read Operation".

If a TC or an implied TC (FIFO overrun/underrun) is received, the FDC stops sending data, but continues to read data from the current sector and checks the CRC bytes until the end of the sector is reached and the READ operation is completed.

The sector size is determined by the N parameter value as calculated in the equation below:

$$\text{Sector Size} = 2^{(7+N \text{ value})} \text{ bytes.}$$

The DTL parameter determines the number of bytes to be transferred. Therefore, if N = 00h, setting the sector size to 128 and the DTL parameter value is less than this, the remaining bytes will be read and checked for CRC errors by the FDC. If this occurs in a WRITE operation, the remaining bytes will be filled with 0. If the sector size is not 128 (N > 00h), DTL should be set to FFh.

In addition to performing Multi-Sector Read operations, the FDC can also perform Multi-Track Read operations. When the MT parameter is set, the FDC can read both sides of a disk automatically.

The combination of N and MT parameter values determines the amount of data that can be transferred during either type of READ operation. Table 9-17 shows the maximum data transfer capacity and the final sector the FDC reads based on these parameters.

Table 9-17. Effects of MT and N Bits

MT	N	Maximum Data Transfer Capacity	Final Sector Read from Disk
0	1	256 X 26 = 6656	26 on side 0 or side 1
1	1	256 X 52 = 13312	26 on side 1
0	2	512 X 15 = 7680	15 on side 0 or side 1
1	2	512 X 30 = 15360	15 on side 1
0	3	1024 X 8 = 8192	8 on side 0 or side 1
1	3	1024 X 16 = 16384	16 on side 1

9.6.11.2 Read Deleted Data

The READ DELETED DATA command is the same as the READ DATA command except that a Deleted Data Address Mark (as opposed to a Data Address Mark) is read in the beginning of the Data Field. This command is typically used to mark a bad sector on a diskette.

9.6.11.3 Read A Track

After receiving a pulse from the INDEX# pin, the READ A TRACK command reads the entire data field from each sector of the track as a continuous block. If any ID or Data Field CRC error is found, the FDC continues to read data from the track and indicates the error at the end. Because the Multi-Track [and Skip] operation[s] is[are] not allowed under this command, the MT and SK bits should be low (0) during the command execution.

This command terminates normally when the number of sectors specified by EOT has not been read. If, however, no ID Address Mark has been found by the second occurrence of the INDEX pulse, the FDC will set the IC code in the ST0 to 01, indicating an abnormal termination, and then finish the command.

9.6.11.4 Write Data

The WRITE DATA command contains nine command bytes that place the FDC into the Write Data mode. Each WRITE operation is initialized by a WRITE DATA command. The FDC locates the sector to be written by reading ID fields and matching the sector address from the command with the information on the diskette. Then the FDC reads the data from the host via the FIFO and writes the data into the sector's data field. Finally, the FDC computes the CRC value, storing it in the CRC field and increments the sector number (stored in the R parameter) by 1. The next data field is written into the next sector in the same manner. Such a continuous write function is called a "Multi-Sector Write Operation".

If a TC or an implied TC (FIFO overrun/underrun) is received, the FDC stops writing data and fills the remaining data field with 0s. If a check of the CRC value indicates an error in the sector ID Field, the FDC will set the IC code in the ST0 to 01 and the DE bit in the ST1 to 1, indicating an abnormal termination, and then terminate the WRITE DATA command. The maximum data transfer capacity and the DTL, N, and MT parameters are the same as in the READ DATA command.

9.6.11.5 Write Deleted Data

The WRITE DELETED DATA command is the same as the WRITE DATA command except that a Deleted Data Address Mark (instead of a Data Address Mark) is written in the beginning of the Data Field. This command is typically used to mark a bad sector on a diskette.

9.6.11.6 FORMAT A TRACK

The FORMAT A TRACK command is used to format an entire track. Initialized by an INDEX pulse, it writes data to the Gaps, Address Marks, ID fields and Data fields according to the density mode selected (FM or MFM). The Gap and Data field values are controlled by the host-specified values programmed into N, SC, GPL, and D during the Command phase. The Data field is filled with the data byte specified by D. The four data bytes per sector (C, H, R, and N) needed to fill the ID field are supplied by the host. The C, R, H, and N values must be renewed for each new sector of a track. Only the R parameter value must be changed when a sector is formatted, allowing the disk to be formatted with non-sequential sector addresses. These steps are repeated until a new INDEX pulse is received, at which point the FORMAT A TRACK command is terminated.

9.6.11.7 SCAN

The SCAN command allows the data read from the disk to be compared with the data sent from the system. There are three SCAN commands:

SCAN EQUAL Disk Data = System Data

SCAN HIGH OR EQUAL Disk Data \geq System Data

SCAN LOW OR EQUAL Disk Data \leq System Data

The SCAN command execution continues until the scan condition has been met, or when the EOT has been reached, or if TC is asserted. Read errors on the disk have the same error condition as the READ DATA command. If the SK bit is set, sectors with Deleted Data Address Marks are ignored. If all sectors read are skipped, the command terminates with the D3 bit of the ST2 being set. The Result phase of the command is

shown below:

Table 9-18. SCAN Command Result

Command	Status Register		Condition
	D2	D3	
SCAN EQUAL	0	1	Disk = System
	1	0	Disk ≠ System
SCAN HIGH OR EQUAL	0	1	Disk = System
	0	0	Disk > System
	1	0	Disk < System
SCAN LOW OR EQUAL	0	1	Disk = System
	0	0	Disk < System
	1	0	Disk > System

9.6.11.8 VERIFY

The VERIFY command is used to read logical sectors containing a Normal Data Address Mark from the selected drive without transferring the data to the host. This command acts like a READ DATA command except that no data are transferred to the host. This command is designed for post-format or post write verification. Data are read from the disk, as the controller checks for valid Address Marks in the Address and Data Fields. The CRC is computed and checked against the previously stored value. Because no data are transferred to the host, the TC (Terminal Count of DMA) cannot be used to terminate this command. An implicit TC will be issued to the FDC by setting the EC bit. This implicit TC will occur when the SC value has been decremented to 0. This command can also be terminated by clearing the EC bit and when the EOT value is equal to the final sector to be checked.

Table 9-19. VERIFY Command Result

MT	EC	SC/EOT	Termination Result
0	0	SC = DTL EOT ≤ # Sectors per side	No Error
0	0	SC = DTL EOT > # Sectors per side	Abnormal Termination
0	1	SC ≤ # Sectors Remaining AND EOT ≤ # Sectors per side	No Error
0	1	SC > # Sectors Remaining OR EOT > # Sectors per side	Abnormal Termination
1	0	SC = DTL EOT > # Sectors per side	No Error
1	0	SC = DTL EOT > # Sectors per side	Abnormal Termination
1	1	SC ≤ # Sectors Remaining AND EOT ≤ # Sectors per side	No Error
1	1	SC > # Sectors Remaining OR EOT > # Sectors per side	Abnormal Termination

9.6.12 Control Commands

The control commands do not transfer any data. Instead, these commands are used to monitor and manage the data transfer. Three of the Control commands generate an interrupt when finished — READ ID, RE-CALIBRATE and SEEK. It is strongly recommended that a SENSE INTERRUPT STATUS command be issued after these commands to capture their valuable interrupt information. The RE-CALIBRATE, SEEK, and SPECIFY commands do not return any result bytes.

9.6.12.1 Read ID

The READ ID command is used to find the actual recording head position. It stores the first readable ID field value into the FDC registers. If the FDC cannot find an ID Address Mark by the time a second INDEX pulse is received, an abnormal termination will be generated by setting the IC code in the ST0 to 01.

9.6.12.2 Configure

The CONFIGURE command determines some special operation modes of the controller. It doesn't need to be issued if the default values of the controller meet the system requirements.

EIS: Enable Implied Seeks. A SEEK operation is performed before a READ, WRITE, SCAN, or VERIFY command.

0 = Disabled (default).

1 = Enabled.

DFIFO: Disable FIFO.

0 = Enabled.

1 = Disabled (default).

POLL: Disable polling of the drives.

0 = Enabled (default). When enabled, a single interrupt is generated after a reset.

1 = Disabled.

FIFOTH: The FIFO threshold in the execution phase of data transfer commands. They are programmable from 00 to 0F hex (1 byte to 16 bytes). Defaults to 1 byte.

PRETRK: The Precompensation Start Track Number. They are programmable from track 0 to FF hex (track 0 to track 255). Defaults to track 0.

9.6.12.3 Re-Calibrate

The RE-CALIBRATE command retracts the FDC read/write head to the track 0 position, resetting the value of the PCN counter and checking the TRK0# status. If TRK0# is low, the DIR# pin remains low and step pulses are issued. If TRK0# is high, SE and EC bits of the ST0 are set high, and the command is terminated. When TRK0# remains low for 79 step pulses, the RE-CALIBRATE command is terminated by setting SE and EC bits of ST0 to high. Consequently, for disks that can accommodate more than 80 tracks, more than one RE-CALIBRATE command is required to retract the head to the physical track 0.

The FDC is in a non-busy state during the Execution phase of this command, making it possible to issue another RE-CALIBRATE command in parallel with the current command.

On power-up, software must issue a RE-CALIBRATE command to properly initialize the FDC and the drives attached.

9.6.12.4 Seek

The SEEK command controls the FDC read/write head movement from one track to another. The FDC compares the current head position, stored in PCN, with NCN values after each step pulse to determine what direction to move the head, if required. The direction of movement is determined below:

PCN < NCN — Step In: Sets DIR# signal to 1 and issues step pulses

PCN > NCN — Step Out: Sets DIR# signal to 0 and issues step pulses

PCN = NCN — Terminate the command by setting the ST0 SE bit to 1

The impulse rate of step pulse is controlled by Stepping Rate Time (SRT) bit in the SPECIFY command. The FDC is in a non-busy state during the Execution phase of this command, making it possible to issue another SEEK command in parallel with the current command.

9.6.12.5 Relative Seek

The RELATIVE SEEK command steps the selected drive in or out in a given number of steps. The DIR bit is used to determine to step in or out. RCN (Relative Cylinder Number) is used to determine how many tracks to step the head in or out from the current track. After the step operation is completed, the controller generates an interrupt. However, the command has no Result phase. No other command except the SENSE INTERRUPT STATUS command should be issued while a RELATIVE SEEK command is in progress.

9.6.12.6 Dumpreg

The DUMPREG command is designed for system run-time diagnostics, application software development, and debug. This command has one byte of Command phase and 10 bytes of Result phase, which return the values of parameters set in other commands.

9.6.12.7 Lock

The LOCK command allows the programmer to fully control the FIFO parameters after a hardware reset. If the LOCK bit is set to 1, the parameters, DFIFO, FIFOTHR, and PRETRK in the CONFIGURE command are not affected by software reset. If the bit is set to 0, those parameters are set to default values after software reset.

9.6.12.8 Version

The VERSION command is used to determine the controller being used. In Result phase, a value of 90 hex is returned in order to be compatible with the 82077.

9.6.12.9 Sense Interrupt Status

The SENSE INTERRUPT STATUS command resets the interrupt signal (IRQ) generated by the FDC, and identifies the cause of the interrupt via the IC code and SE bit of the ST0 as shown in Table 9-20.

It may be necessary to generate an interrupt when any of the following conditions occur:

- Before any Data Transfer or READ ID command
- After SEEK or RE-CALIBRATE commands (no result phase exists)
- When a data transfer is required during an Execution phase in the non-DMA mode

Table 9-20. Interrupt Identification

SE	IC Code	Cause of Interrupt
0	11	Polling.
1	00	Normal termination of SEEK or RE-CALIBRATE command.
1	01	Abnormal termination of SEEK or RE-CALIBRATE command.

9.6.12.10 Sense Drive Status

The SENSE DRIVE STATUS command acquires drive status information. It has no Execution phase.

9.6.12.11 Specify

The SPECIFY command sets the initial values for the HUT (Head Unload Time), HLT (Head Load Time), SRT (Step Rate Time), and ND (Non-DMA mode) parameters. The possible values for HUT, SRT, and HLT are shown in Table 10-20, Table 10-21 and Table 10-22 respectively. The FDC is operated in DMA or non-DMA mode based on the value specified by the ND parameters.

Table 9-21. HUT Values

Parameter	1 Mbps	500 Kbps	300 Kbps	250 Kbps
0	128	256	426	512
1	8	16	26.7	32
-	-	-	-	-
E	112	224	373	448
F	120	240	400	480

Table 9-22. SRT Values

Parameter	1 Mbps	500 Kbps	300 Kbps	250 Kbps
0	8	16	26.7	32
1	7.5	15	25	30
-	-	-	-	-
E	1	2	3.33	4
F	0.5	1	1.67	2

Table 9-23. HLT Values

Parameter	1 Mbps	500 Kbps	300 Kbps	250 Kbps
00	128	256	426	512
01	1	2	3.33	4
02	2	4	6.7	8
-	-	-	-	-
7E	126	252	420	504
7F	127	254	423	508

9.6.12.12 Perpendicular Mode

The PERPENDICULAR MODE command is used to support the unique READ/WRITE/FORMAT commands of Perpendicular Recording disk drives (4 Mbytes unformatted capacity). This command configures each of the four logical drives as a perpendicular or conventional disk drive via the DC3-DC0 bits, or with the GAP and WG control bits. Perpendicular Recording drives operate in "Extra High Density" mode at 1 Mbps, and are downward compatible with 1.44 Mbyte and 720 kbyte drives at 500 Kbps (High Density) and 250 Kbps (Double Density) respectively. This command should be issued during the initialization of the floppy disk controller. Then, when a drive is accessed for a FORMAT A TRACK or WRITE DATA command, the controller adjusts the format or Write Data parameters based on the data rate. If WG and GAP are used (not set to 00), the operation of the FDC is based on the values of GAP and WG. If WG and GAP are set to 00, setting DCn to 1 will set drive n to the Perpendicular mode. DC3-DC0 are unaffected by software reset, but WG and GAP are both cleared to 0 after software reset.

Table 9-24. Effects of GAP and WG on FORMAT A TRACK and WRITE DATA Commands

GAP	WG	Mode	Length of GAP2 FORMAT FIELD	Portion of GAP2 Re-Written by WRITE DATA Command
0	0	Conventional	22 bytes	0 bytes
0	1	Perpendicular (500 Kbps)	22 bytes	19 bytes
1	0	Reserved (Conventional)	22 bytes	0 bytes
1	1	Perpendicular (1 Mbps)	41 bytes	38 bytes

Table 9-25. Effects of Drive Mode and Data Rate on FORMAT A TRACK and WRITE DATA Commands

Data Rate	Drive Mode	Length of GAP2 FORMAT FIELD	Portion of GAP2 Re-Written by WRITE DATA Command
250/300/500 Kbps	Conventional	22 bytes	0 bytes
	Perpendicular	22 bytes	19 bytes
1 Mbps	Conventional	22 bytes	0 bytes
	Perpendicular	41 bytes	38 bytes

9.6.12.13 Invalid

The INVALID command indicates when an undefined command has been sent to FDC. The FDC will set bit 6 and bit 7 in the Main Status Register to 1 and terminate the command without issuing an interrupt.

9.6.13 DMA Transfers

DMA transfers are enabled by the SPECIFY command and are initiated by the FDC by activating the LDRQ# cycle during a DATA TRANSFER command. The FIFO is enabled directly by asserting the LPC DMA cycles.

9.6.14 Low Power Mode

When writing a 1 to bit 6 of the DSR, the controller is set to a low power mode immediately. All the clock sources including Data Separator, Microcontroller, and Write precompensation unit, will be gated. The FDC can be resumed from the low-power state in two ways: one is a software reset via the DOR or DSR, and the other is a read or write to either the Data Register or Main Status Register. The second method is more preferred since all internal register values are retained.

9.7 Serial Port (UART) Description

The IT8722F incorporates two enhanced serial ports that perform serial to parallel conversion on received data, and parallel to serial conversion on transmitted data. Each of the serial channels individually contains a programmable baud rate generator which is capable of dividing the input clock by a number ranging from 1 to 65535. The data rate of each serial port can also be programmed from 115.2K baud down to 50 baud. The character options are programmable for 1 start bit; 1, 1.5 or 2 stop bits; even, odd, stick or no parity; and privileged interrupts.

Table 9-26. Serial Channel Registers

Register	DLAB*	Address	READ	WRITE
Data	0	Base + 0h	RBR (Receiver Buffer Register)	TBR (Transmitter Buffer Register)
Control	0	Base + 1h	IER (Interrupt Enable Register)	IER
	x	Base + 2h	IIR (Interrupt Identification Register)	FCR (FIFO Control Register)
	x	Base + 3h	LCR (Line Control Register)	LCR
	x	Base + 4h	MCR (Modem Control Register)	MCR
	1	Base + 0h	DLL (Divisor Latch LSB)	DLL
	1	Base + 1h	DLM (Divisor Latch MSB)	DLM
Status	x	Base + 5h	LSR (Line Status Register)	LSR
	x	Base + 6h	MSR (Modem Status Register)	MSR
	x	Base + 7h	SCR (Scratch Pad Register)	SCR

* DLAB is bit 7 of the Line Control Register.

9.7.1 Data Registers

The TBR and RBR individually hold from five to eight data bits. If the transmitted data are less than eight bits, they align to the LSB. Either received or transmitted data are buffered by a shift register, and are latched first by a holding register. Bit 0 of any word is first received and transmitted.

(1) Receiver Buffer Register (RBR) (Read only, Address offset=0, DLAB=0)

This register receives and holds the incoming data. It contains a non-accessible shift register which converts the incoming serial data stream into a parallel 8-bit word.

(2) Transmitter Buffer Register (TBR) (Write only, Address offset=0, DLAB=0)

This register holds and transmits the data via a non-accessible shift register, and converts the outgoing parallel data into a serial stream before the data transmission.

9.7.2 Control Registers: IER, IIR, FCR, DLL, DLM, LCR and MCR

(1) Interrupt Enable Register (IER) (Read/Write, Address offset=1, DLAB=0)

The IER is used to enable (or disable) four active high interrupts which activate the interrupt outputs with its lower four bits: IER(0), IER(1), IER(2), and IER(3).

Table 9-27. Interrupt Enable Register Description

Bit	Default	Description
7-4	-	Reserved
3	0	Enable MODEM Status Interrupt Sets this bit high to enable the Modem Status Interrupt when one of the Modem Status Registers changes its bit status.
2	0	Enable Receiver Line Status Interrupt Sets this bit high to enable the Receiver Line Status Interrupt which is caused when Overrun, Parity, Framing or Break occurs.
1	0	Enable Transmitter Holding Register Empty Interrupt Sets this bit high to enable the Transmitter Holding Register Empty Interrupt.
0	0	Enable Received Data Available Interrupt Sets this bit high to enable the Received Data Available Interrupt and Time-out interrupt in the FIFO mode.

(2) Interrupt Identification Register (IIR) (Read only, Address offset=2)

This register facilitates the host CPU to determine interrupt priority and its source. The priority of four existing interrupt levels is listed below:

1. Receiver Line Status (highest priority)
2. Received Data Ready
3. Transmitter Holding Register Empty
4. Modem Status (lowest priority)

When a privileged interrupt is pending and the type of interrupt is stored in the IIR which is accessed by the Host, the serial channel holds back all interrupts and indicates the pending interrupts with the highest priority to the Host. Any new interrupts will not be acknowledged until the Host access is completed. The contents of the IIR are described in the table on the next page.

Table 9-28. Interrupt Identification Register

FIFO Mode	Interrupt Identification Register			Interrupt Set and Reset Functions			
	Bit 3	Bit 2	Bit 1	Bit 0	Priority Level	Interrupt Type	Interrupt Source
0	X	X	1	-	None	None	-
0	1	1	0	First	Receiver Line Status	OE, PE, FE, or BI	Read LSR
0	1	0	0	Second	Received Data Available	Received Data Available	Read RBR or FIFO drops below the trigger level
1	1	0	0	Second	Character Time-out Indication	No characters have been removed from or input to the RCVR FIFO during the last 4 character times and there is at least 1 character in it during this time	Read RBR
0	0	1	0	Third	Transmitter Holding Register Empty	Transmitter Holding Register Empty	Read IIR if THRE is the Interrupt Source Write THR
0	0	0	0	Fourth	Modem Status	CTS#, DSR#, RI#, DCD#	Read MSR

Note: X = Not Defined

IIR(7), IIR(6): Are set when FCR(0) = 1.

IIR(5), IIR(4): Always logic 0.

IIR(3): In non-FIFO mode, this bit is a logic 0. In the FIFO mode, this bit is set along with bit 2 when a time-out interrupt is pending.

IIR(2), IIR(1): Used to identify the highest priority interrupt pending.

IIR(0): Used to indicate a pending interrupt in either a hard-wired prioritized or polled environment with a logic 0 state. In such a case, IIR contents may be used as a pointer that points to the appropriate interrupt service routine.

(3) FIFO Control Register (FCR) (Write Only, Address offset=2)

This register is used to enable, clear the FIFO, and set the RCVR FIFO trigger level.

Table 9-29. FIFO Control Register Description

Bit	Default	Description
7-6	-	Receiver Trigger Level Select These bits set the trigger levels for the RCVR FIFO interrupt.
5-4	0	Reserved
3	0	This bit does not affect the Serial Channel operation. RXRDY and TXRDY functions are not available on this chip.
2	0	Transmitter FIFO Reset This self-clearing bit clears all contents of the XMIT FIFO and resets its related counter to 0 via a logic "1."
1	0	Receiver FIFO Reset Setting this self-clearing bit to a logic 1 clears all contents of the RCVR FIFO and resets its related counter to 0 (except the shift register).
0	0	FIFO Enable XMIT and RCVR FIFOs are enabled when this bit is set high. XMIT and RCVR FIFOs are disabled and cleared respectively when this bit is cleared to low. This bit must be a logic 1 if the other bits of the FCR are written to, or they will not be properly programmed. When this register is switched to non-FIFO mode, all its contents are cleared.

Table 9-30. Receiver FIFO Trigger Level Encoding

FCR (7)	FCR (6)	RCVR FIFO Trigger Level
0	0	1 byte
0	1	4 bytes
1	0	8 bytes
1	1	14 bytes

(4) Divisor Latches (DLL, DLM) (Read/Write, Address offset=0,1 DLAB=0)

Two 8-bit Divisor Latches (DLL and DLM) store the divisor values in a 16-bit binary format. They are loaded during the initialization to generate a desired baud rate.

(5) Baud Rate Generator (BRG)

Each serial channel contains a programmable BRG which can make any clock input (from DC to 8 MHz) to generate standard ANSI/CCITT bit rates for the channel clocking with an external clock oscillator. The DLL or DLM is a number of 16-bit format, providing the divisor ranging from 1 to 2^{16} to obtain the desired baud rate. The output frequency is 16X data rate.

Table 9-31. Baud Rates Using (24 MHz ÷ 13) Clock

Desired Baud Rate	Divisor Used
50	2304
75	1536
110	1047
134.5	857
150	768
300	384
600	192
1200	96
1800	64
2000	58
2400	48
3600	32
4800	24
7200	16
9600	12
19200	6
38400	3
57600	2
115200	1

(6) Scratch Pad Register (Read/Write, Address offset=7)

This 8-bit register does not control the UART operation in any way. It is intended as a scratch pad register to be used by programmers to temporarily hold general purpose data.

(7) Line Control Register (LCR) (Read/Write, Address offset=3)

LCR controls the format of the data character and supplies the information of the serial line. Its contents are described on the next page.

Table 9-32. Line Control Register Description

Bit	Default	Description
7	0	Divisor Latch Access Bit (DLAB) It must be set high to access the Divisor Latches of the baud rate generator during READ or WRITE operations. It must be set low to access the Data Registers (RBR and TBR) or the Interrupt Enable Register.
6	0	Set Break Forces the Serial Output (SOUT) to the spacing state (logic 0) by a logic 1, and this state will be preserved until a low level resetting LCR(6), enabling the serial port to alert the terminal in a communication system.
5	0	Stick Parity When this bit and LCR(3) are high at the same time, the parity bit is transmitted, and then detected by receiver, in opposite state by LCR(4) to force the parity bit into a known state and to check the parity bit in a known state.
4	0	Even Parity Select When parity is enabled (LCR(3) = 1), LCR(4) = 0 selects odd parity, and LCR(4) = 1 selects even parity.
3	0	Parity Enable A parity bit, located between the last data word bit and stop bit, will be generated or checked (transmit or receive data) when LCR(3) is high.
2	0	Number of Stop Bits This bit specifies the number of stop bit in each serial character, as summarized in table 10-32.
1-0	00	Word Length Select [1:0] 11: 8 bits 10: 7 bits 01: 6 bits 00: 5 bits

Table 9-33. Stop Bits Number Encoding

LCR (2)	Word Length	No. of Stop Bits
0	-	1
1	5 bits	1.5
1	6 bits	2
1	7 bits	2
1	8 bits	2

Note: The receiver will ignore all stop bits beyond the first, regardless of the number used in transmission.

(8) MODEM Control Register (MCR) (Read/Write, Address offset=4)

Controls the interface by the modem or data set (or device emulating a modem).

Table 9-34. Modem Control Register Description

Bit	Default	Description
7-5	-	Reserved
4	0	Internal Loopback Provides a loopback feature for the diagnostic test of the serial channel when it is set high. Serial Output (SOUT) is set to the Marking State Shift Register output loops back into the Receiver Shift Register. All Modem Control inputs (CTS#, DSR#, RI# and DCD#) are disconnected. The four Modem Control outputs (DTR#, RTS#, OUT1 and OUT2) are internally connected to the four Modem Control inputs, and are forced to inactivate high and the transmitted data are immediately received, allowing the processor to verify the transmit and receive data path of the serial channel.
3	0	OUT2 The Output 2 bit enables the serial port interrupt output by a logic 1.
2	0	OUT1 This bit does not have an output pin and can only be read or written by the CPU.
1	0	Request to Send (RTS) Controls the Request to Send (RTS#) which is in an inverse logic state with that of MCR(1).
0	0	Data Terminal Ready (DTR) Controls the Data Terminal ready (DTR#) which is in an inverse logic state with that of the MCR(0).

9.7.3 Status Registers: LSR and MSR**(1) Line Status Register (LSR) (Read/Write, Address offset=5)**

This register provides status indications and is usually the first register read by the CPU to determine the cause of an interrupt or to poll the status of each serial channel. The contents of the LSR are described below:

Table 9-35. Line Status Register Description

Bit	Default	Description
7	0	Error in Receiver FIFO In the 16450 mode, this bit is always 0. In the FIFO mode, it sets high when there is at least one parity error, framing or break interrupt in the FIFO. This bit is cleared when the CPU reads the LSR, if there are no subsequent errors in the FIFO.
6	1	Transmitter Empty This read only bit indicates that the Transmitter Holding Register and Transmitter Shift Register are both empty. Otherwise, this bit is "0" and has the same function in the FIFO mode.

Table 9-34. Line Status Register Description [cont'd]

Bit	Default	Description
5	1	Transmitter Holding Register Empty Transmitter Holding Register Empty (THRE). This read only bit indicates that the TBR is empty and is ready to accept a new character for transmission. It is set high when a character is transferred from the THR into the Transmitter Shift Register, causing a priority 3 IIR interrupt which is cleared by a read of IIR. In the FIFO mode, it is set when the XMIT FIFO is empty, and is cleared when at least one byte is written to the XMIT FIFO.
4	0	Line Break Break Interrupt (BI) status bit indicates that the last character received was a break character, (invalid but entire character), including parity and stop bits. This occurs when the received data input is held in the spacing (logic 0) for longer than a full word transmission time (start bit + data bits + parity + stop bit). When any of these error conditions is detected (LSR(1) to LSR(4)), a Receiver Line Status interrupt (priority 1) will be generated in the IIR, with the IER(2) previously enabled.
3	0	Framing Error Framing Error (FE) bit, a logic 1, indicates that the stop bit in the received character is not valid. It resets low when the CPU reads the contents of the LSR.
2	0	Parity Error Parity error (PE) indicates by a logic 1 that the received data character does not have the correct even or odd parity, as selected by LCR(4). It will be reset to "0" whenever the LSR is read by the CPU.
1	0	Overrun Error Overrun Error (OE) bit indicates by a logic 1 that the RBR has been overwritten by the next character before it had been read by the CPU. In the FIFO mode, the OE occurs when the FIFO is full and the next character has been completely received by the Shift Register. It will be reset when the LSR is read by the CPU.
0	0	Data Ready A "1" indicates a character has been received by the RBR. A logic "0" indicates all the data in the RBR or the RCVR FIFO have been read.

(2) MODEM Status Register (MSR) (Read/Write, Address offset=6)

This 8-bit register indicates the current state of the control lines with modems or the peripheral devices in addition to this current state information. Four of these eight bits MSR(4) - MSR(7) can provide the state change information when a modem control input changes the state. It is reset low when the Host reads the MSR.

Table 9-36. Modem Status Register Description

Bit	Default	Description
7	0	Data Carrier Detect Data Carrier Detect - Indicates the complement status of Data Carrier Detect (DCD#) input. If MCR(4) = 1, MSR(7) is equivalent to OUT2 in the MCR.
6	0	Ring Indicator Ring Indicator (RI#) - Indicates the complement status to the RI# input. If MCR(4)=1, MSR(6) is equivalent to OUT1 in the MCR.
5	0	Data Set Ready Data Set Ready (DSR#) - Indicates that the modem is ready to provide received data to the serial channel receiver circuitry. If the serial channel is in the Loop mode (MCR(4) = 1), MSR(5) is equivalent to DTR# in the MCR.
4	0	Clear to Send Clear to Send (CTS#) - Indicates the complement of CTS# input. When the serial channel is in the Loop mode (MCR(4)=1), MSR(5) is equivalent to RTS# in the MCR.
3	0	Delta Data Carrier Detect I Indicates that the DCD# input state has been changed since the last time read by the Host.
2	0	Trailing Edge Ring Indicator Indicates that the RI input state to the serial channel has been changed from a low to high since the last time read by the Host. The change to a logic "1" does not activate the TERI.
1	0	Delta Data Set Ready Delta Data Set Ready (DDSR) - A logic "1" indicates that the DSR# input state to the serial channel has been changed since the last time read by the Host.
0	0	Delta Clear to Send This bit indicates the CTS# input to the chip has changed state since the last time the MSR was read.

9.7.4 Reset

The reset of the IT8722F should be held to an idle mode reset high for 500 ns until initialization, which causes the initialization of the transmitter and receiver internal clock counters.

Table 9-37. Reset Control of Registers and Pinout Signals

Register/Signal	Reset Control	Reset Status
Interrupt Enable Register	Reset	All bits Low
Interrupt Identification Register	Reset	Bit 0 is high and bits 1-7 are low
FIFO Control Register	Reset	All bits Low
Line Control Register	Reset	All bits Low
Modem Control Register	Reset	All bits Low
Line Status Register	Reset	Bits 5 and 6 are high, others are low
Modem Status Register	Reset	Bits 0-3 low, bits 4-7 input signals
SOUT1, SOUT2	Reset	High
RTS1#, RTS2#, DTR1#, DTR2#	Reset	High
IRQ of Serial Port	Reset	High Impedance

9.7.5 Programming

Each serial channel of the IT8722F is programmed by control registers, whose contents define the character length, number of stop bits, parity, baud rate and modem interface. Even though the control register can be written in any given order, the IER should be the last register written because it controls the interrupt enables. After the port is programmed, these registers can still be updated whenever the port is not transferring data.

9.7.6 Software Reset

This approach allows the serial port to return to a completely known state without a system reset. This is achieved by writing the required data to the LCR, DLL, DLM and MCR. The LSR and RBR must be read before interrupts are enabled to clear out any residual data or status bits that may be invalid for subsequent operations.

9.7.7 Clock Input Operation

The input frequency of the Serial Channel is $24 \text{ MHz} \div 13$, not exactly 1.8432 MHz.

9.7.8 FIFO Interrupt Mode Operation

(1) RCVR Interrupt

When setting $\text{FCR}(0)=1$ and $\text{IER}(0)=1$, the RCVR FIFO and receiver interrupts are enabled. The RCVR interrupt occurs under the following conditions:

The receive data available interrupt will be issued only if the FIFO has reached its programmed trigger level. They will be cleared as soon as the FIFO drops below its trigger level.

The receiver line status interrupt has higher priority over the received data available interrupt.

The time-out timer will be reset after a new character is received or the Host reads the RCVR FIFO whenever a time-out interrupt occurs. The timer will be reset when the Host reads one character from the RCVR FIFO.

RCVR FIFO time-out Interrupt: By enabling the RCVR FIFO and receiver interrupts, the RCVR FIFO time-out interrupt will occur under the following conditions:

The RCVR FIFO time-out interrupt will occur only if there is at least one character in the FIFO whenever the interval between the latest received serial character and the latest Host READ from the FIFO is longer than four consecutive character times.

The time-out timer will be reset after a new character is received or the Host reads the RCVR FIFO whenever a time-out interrupt occurs. The timer will be reset when the Host reads one character from the RCVR FIFO.

(2) XMIT Interrupt

By setting $\text{FCR}(0)$ and $\text{IER}(1)$ to high, the XMIT FIFO and transmitter interrupts are enabled, and the XMIT interrupt occurs under the conditions described below:

- a. The transmitter interrupt occurs when the XMIT FIFO is empty, and it will be reset if the THR is written or the IIR is read.
- b. The transmitter FIFO empty indications will be delayed one character time minus the last stop bit time whenever the following condition occurs: $\text{THRE} = 1$ and there have not been at least two bytes in the transmitter FIFO at the same time since the last $\text{THRE} = 1$. The transmitter interrupt after changing $\text{FCR}(0)$ will be immediate, if it is enabled. Once the first transmitter interrupt is enabled, the THRE indication is delayed one character time minus the last stop bit time.

The character time-out and RCVR FIFO trigger level interrupts are in the same priority order as the received data available interrupt. The XMIT FIFO empty is in the same priority as the transmitter holding register empty interrupt.

FIFO Polled Mode Operation [FCR(0)=1, and IER(0), IER(1), IER(2), IER(3) or all are 0].

Either XMIT or RCVR can be in this operation mode. The operation mode can be programmed by users and is responsible for checking the RCVR and XMIT status via the LSR described below:

LSR(7): RCVR FIFO error indication.

LSR(6): XMIT FIFO and Shift register empty.

LSR(5): The XMIT FIFO empty indication.

LSR(4) - LSR(1): Specify that errors have occurred. Character error status is handled in the same way as in the interrupt mode. The IIR is not affected since IER(2)=0.

LSR(0): High whenever the RCVR FIFO contains at least one byte.

No trigger level is reached or time-out condition indicated in the FIFO Polled Mode.

9.8 Smart Card Reader

9.8.1 Features

As an IFD (InterFace Device) built in IT8722F, the Smart Card Reader (SCR) includes a standard UART (Either Serial Port 1 or Serial Port 2 is set in SCR mode) to control Smart Card interface handshaking and then performs data transfers, and can be connected to smart card socket directly. The Smart Card is capable of providing secured storage facilities for sensitive personal information (such as Private keys, Account numbers, Passwords, Medical information, ...etc.). Then the SCR can be used for a broad range of applications in GSM, ID, pay TV, banking (refer to EMV'96 Spec.), ... and so forth. It also provides a Smart Card clock divider for those ICC (Integrated Circuit Card) without internal clocks.

9.8.2 Operation

The SCR is a low-power consumption design. Whenever the IFD is inactive, the clock divider will turn off internal clocks even when the clock of IFD controlling / monitoring state machine is turned off to save power consumption. Also it could be waked up immediately when IC card is removed in case of an emergency or when the FET control function is turned on/off.

The VCC power of IC card interface is powered from an external FET to protect the smart card interface. Also, the charge/discharge time for FET to reach 5V/0V is programmable, and FET performs automatically to meet ISO 7816 activation and deactivation sequences. The UART's modem control lines: DTR#, RTS# and DCD# are used for controlling FET on/off, Smart Card Reset signal and IC card insertion detection respectively. When an IC card is being inserted, it will switch the SCRPRES# (Smart Card Present Detect#) and then cause the DCD# signal to trigger an interrupt to the system. Then in the Smart Card interrupt service routine, the driver can assert the DTR# signal to power on the external FET (SCRPFET#) and the RTS# signal to control the Smart Card Reset signal (SCRRST). Meanwhile, IT8722F will generate a proper clock frequency to allow the IC card to using default serial transfer baud rate to send back an ATR (Answer-To-Reset) sequence. The interface signals are enabled after VCC reaches enough voltage level. Then transfer protocol may be negotiated to promote more efficient transfers. In the same way, when the IC card is removed in case of an emergency or when the ICC processing is finished, the driver can de-assert the DTR# to turn off the FET power. However, before the FET power-off and the reset, clock and data signals will be de-active, followed by a sufficient FET discharge time guaranteed to protect IC card and IFD.

9.8.3 Connection of IFD to ICC Socket

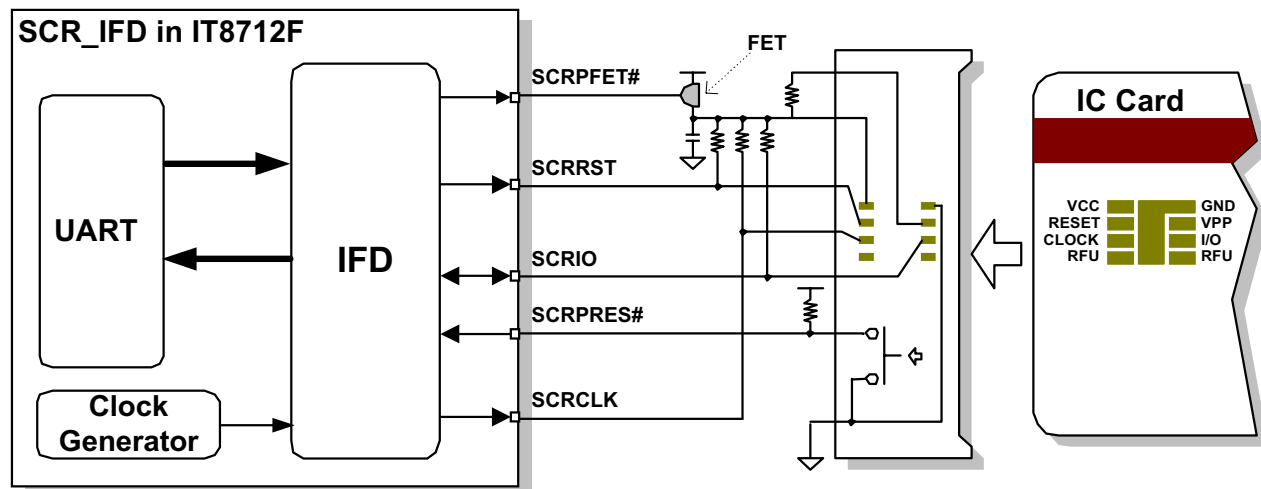

Figure 9-7. Smart Card Reader Application

9.8.4 Baud Rate Relationship Between UART and Smart Card Interface

To perform serial transfers correctly, the baud rate of UART must be set in the way similar to the ICC card.

- **Formula (Variation < 2%)**

$$\text{Baud Rate} = \frac{\text{UART } 24 \text{ MHz}}{13 \cdot 16 \cdot N} \approx \frac{\text{Smart Card } \text{SCRCLK} \cdot D}{F}$$

N = Divisor of UART, assigned by programming the DLM (Divisor Latch MSB) and DLL (Divisor Latch LSB).

F = Clock Rate Conversion Factor, default = 372.

D = Bit Rate Adjustment Factor, Default is 1.

SCRCLK duty cycle is 45%-55%.

- **ICC With Internal Clock**

ICC may use built-in internal clock, then the baud rate is 9600 baud, just programming the Divisor Latch Registers of UART in the IT8722F for SCR IFD.

- **ICC Without Internal Clock**

Baud rate is SCRCLK/372 before negotiating, and SCRCLK is limited within 1 MHz - 5MHz. During the ATR sequence, the default F value (Clock Rate Conversion Factor) is 372, and the default D value (Bit Rate Adjustment Factor) is 1.

9.8.5 Waveform Relationship

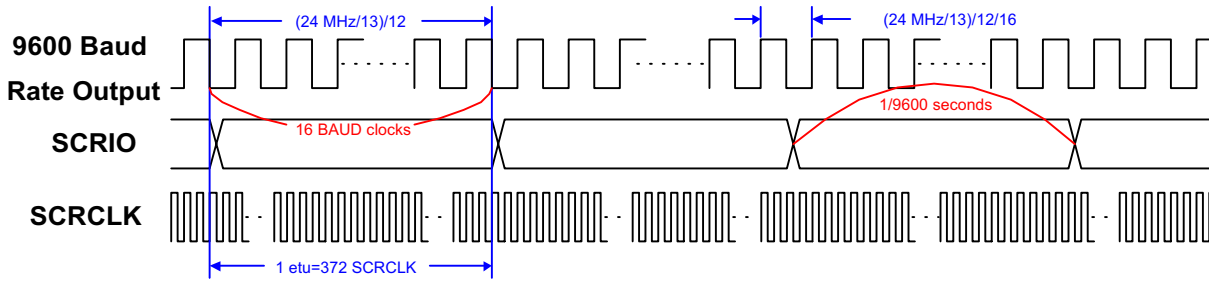

Figure 9-8. 9600 Baud Rate Example

9.8.6 Clock Divider

The SCRCLK is generated as the selection of SCR_CLKSEL1-0, which is determined in the S1 Special Configuration register 3 (LDN1_F2h) or S2 Special Configuration register 3 (LDN2_F2h).

Table 9-38. SCRCLK Selections

SCR_CLKSEL1-0	Selections
00	Stop
01	3.5 MHz
10	7.1 MHz
11	96 MHz / SCR DIV96M ^{Note}

Note: SCR DIV96M is determined by S1 Special Configuration Register 4 (LDN1_F3h) or S2 Special Configuration Register 4 (LDN2_F4h).

9.8.7 Waveform Example of Activation/Deactivation Sequence

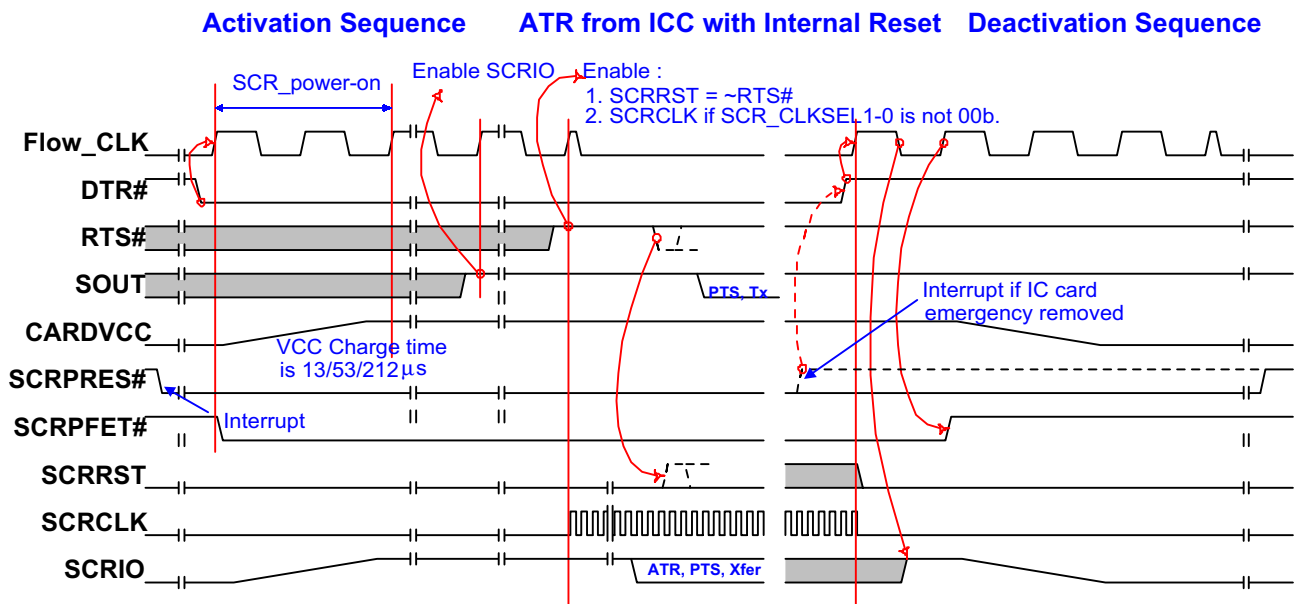

Figure 9-9. Waveform Example of IFD

• Activation Sequence

Refer to the waveform above. The SCR IFD in the IT8722F will make sure the IFD is in data receive mode (i.e. the SOUT from UART is high), and the RTS# should be programmed to high. The SCRCLK is then enabled to output to the IC card (which means that the IC card can count SCRCLK clock numbers to start ATR responses), the data transfer is then enabled, and the SCRRST is the inverse logic state of RTS#. Also, the operation procedure guarantees the correct activation sequence even if the driver can not program the SCRCLK and SCRRST in the precise time points. In this way, the hardware meets the ICC specification.

- **ATR**

For the IC card with its own internal reset, its ATR begins within 400-40000 SCRCLK cycles. If no ATR is detected, the Smart Card IFD driver can then program the RTS# to low and cause the SCRRST to high.

For some types of IC cards without internal reset signals, it will check out the SCRRST as active low reset, and begins its ATR within 400-40000 SCRCLK cycles from the time point of SCRRST rising edge. The IT8722F does not support the type of IC Card that may send synchronous ATRs.

- **Deactivation and PTS Structure**

Whenever the IC card is removed or when the IFD driver intends to power off the SCR interface, the IFD will enter the deactivation sequence.

9.8.8 ATR and PTS Structure

The contents of the ATR (Answer-To-Reset) and PTS (Protocol-Type-Select) are defined in ISO/IEC 7816-X standards, which must be fully communicated by the ICC Resource manager, the ICC Service provider or the ICC application software.

After finalizing the coherent protocol, the SCR IFD enters the normal transfer mode. Since the SCRIO is the only data channel for both data transmit and receive as defined in the ICC Specification, the IT8722F can only support the half-duplex function. The SCRRST can be reset when a data transfer error occurs, and then the IFD driver will select a safer, lower-speed protocol to perform the data transfers again.

9.8.9 Smart Card Operating Sequence Example

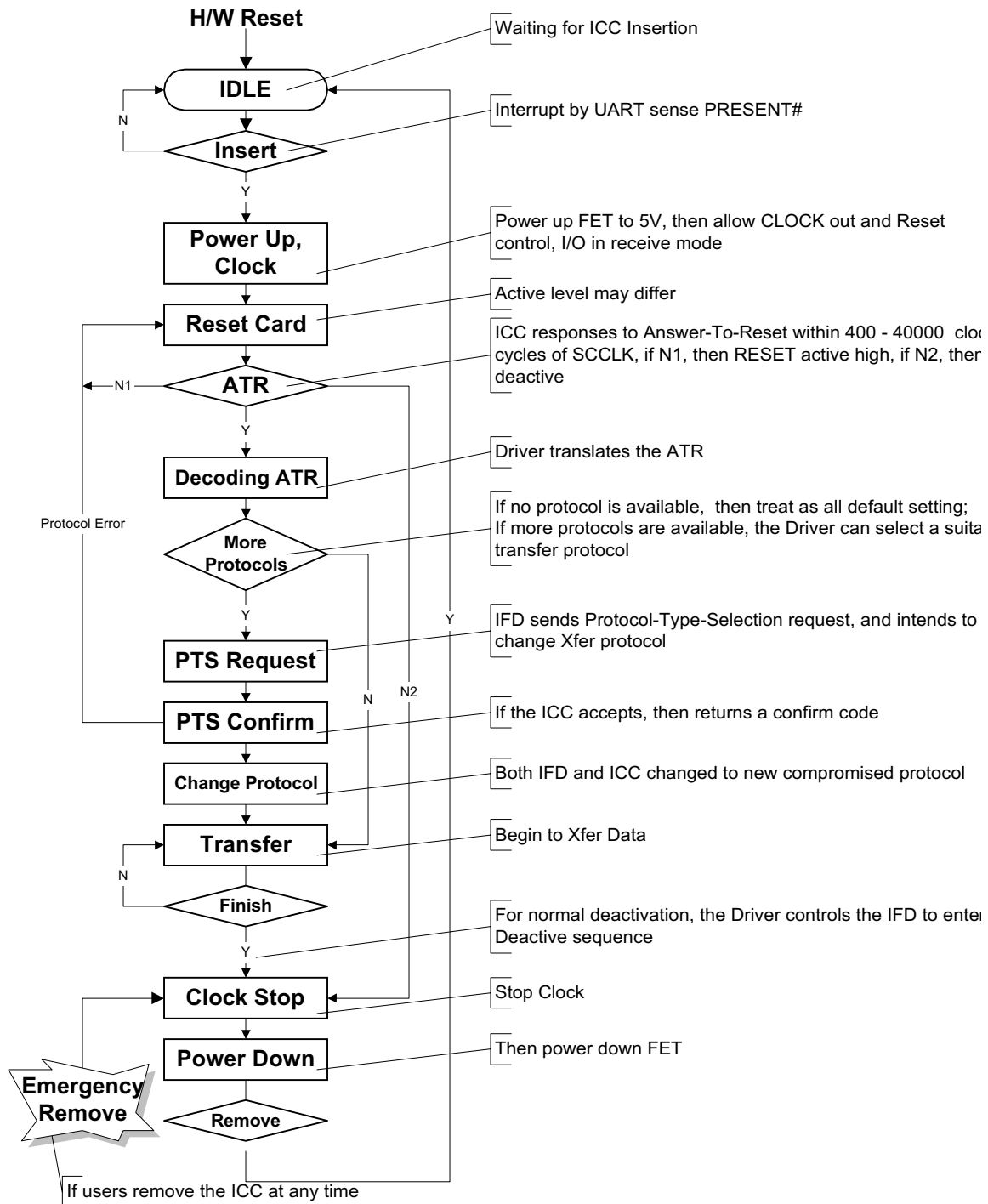

9.9 Parallel Port

The IT8722F incorporates one multi-mode high performance parallel port, which supports the IBM AT, PS/2 compatible bi-directional Standard Parallel Port (SPP), the Enhanced Parallel Port (EPP) and the Extended Capabilities Port (ECP). Please refer to the IT8722F Configuration registers and Configuration Description for information on enabling/disabling, changing the base address of the parallel port, and operation mode selection.

Table 9-39. Parallel Port Connector in Different Modes

Host Connector	Pin No.	SPP	EPP	ECP
1	108	STB#	WRITE#	nStrobe
2-9	109-116	PD0 - 7	PD0 - 7	PD0 - 7
10	103	ACK#	INTR	nAck
11	102	BUSY	WAIT#	Busy PeriphAck(2)
12	101	PE	(NU) (1)	PError nAckReverse(2)
13	100	SLCT	(NU) (1)	Select
14	107	AFD#	DSTB#	nAutoFd HostAck(2)
15	106	ERR#	(NU) (1)	nFault nPeriphRequest(2)
16	105	INIT#	(NU) (1)	nInit nReverseRequest(2)
17	104	SLIN#	ASTB#	nSelectIn

Note 1: NU: Not used.

Note 2: Fast mode.

Note 3: For more information, please refer to the IEEE 1284 standard.

9.9.1 SPP and EPP Modes

Table 9-40. Address Map and Bit Map for SPP and EPP Modes

Register	Address	I/O	D0	D1	D2	D3	D4	D5	D6	D7	Mode
Data Port	Base 1+0h	R/W	PD0	PD1	PD2	PD3	PD4	PD5	PD6	PD7	SPP/EPP
Status Port	Base 1+1h	R	TMOU T	1	1	ERR#	SLCT	PE	ACK#	BUSY#	SPP/EPP
Control Port	Base 1+2h	R/W	STB	AFD	INIT	SLIN	IRQE	PDDIR	1	1	SPP/EPP
EPP Address Port	Base 1+3h	R/W	PD0	PD1	PD2	PD3	PD4	PD5	PD6	PD7	EPP
EPP Data Port0	Base 1+4h	R/W	PD0	PD1	PD2	PD3	PD4	PD5	PD6	PD7	EPP
EPP Data Port1	Base 1+5h	R/W	PD0	PD1	PD2	PD3	PD4	PD5	PD6	PD7	EPP
EPP Data Port2	Base 1+6h	R/W	PD0	PD1	PD2	PD3	PD4	PD5	PD6	PD7	EPP
EPP Data Port3	Base 1+7h	R/W	PD0	PD1	PD2	PD3	PD4	PD5	PD6	PD7	EPP

Note 1: The Base address 1 depends on the Logical Device configuration registers of Parallel Port (0X60, 0X61).

(1) Data Port (Base Address 1 + 00h)

This is a bi-directional 8-bit data port. The direction of data flow is determined by bit 5 of the logic state of the control port register. It forwards directions when the bit is low and reverses directions when the bit is high.

(2) Status Port (Base Address 1 + 01h)

This is a **read only** register. Writing to this register has no effects. The contents of this register are latched during an IOR cycle.

Bit 7 - BUSY#: Inverse of printer BUSY signal, a logic "0" means that the printer is busy and cannot accept another character. A logic "1" means that it is ready to accept the next character.

Bit 6 - ACK#: Printer acknowledge, a logic "0" means that the printer has received a character and is ready to accept another. A logic "1" means that it is still processing the last character.

Bit 5 - PE: Paper end, a logic "1" indicates the paper end.

Bit 4 - SLCT: Printer selected, a logic "1" means that the printer is on line.

Bit 3 - ERR#: Printer error signal, a logic "0" means an error has been detected.

Bits 2, 1 - Reserved: These bits are always "1" when read.

Bit 0 - TMOU: This bit is valid only in EPP mode and indicates that a 10-msec time-out has occurred in EPP operation. A logic "0" means that no time-out occurred and a logic "1" means that a time-out error has been detected. This bit is cleared by an LRESET# or by writing a logic "1" to it. When the IT8722F is selected to non-EPP mode (SPP or ECP), this bit is always a logic "1" when read.

(3) Control Port (Base Address 1 + 02h)

This port provides all output signals to control the printer. The register can be read and written.

Bits 6, 7 - Reserved: These two bits are always "1" when read.

Bit 5 - PDDIR: Data port direction control. This bit determines the direction of the data port register. Set this bit "0" to output the data port to PD bus, and "1" to input from PD bus.

Bit 4 - IRQE: Interrupt request enable. Setting this bit "1" enables the interrupt requests from the parallel port to the Host. An interrupt request is generated by a "0" to "1" transition of the ACK# signal.

Bit 3 - SLIN: Inverse of SLIN# pin. Setting this bit to "1" selects the printer.

Bit 2 - INIT: Initiate printer. Setting this bit to "0" initializes the printer.

Bit 1 - AFD: Inverse of the AFD# pin. Setting this bit to "1" causes the printer to automatically advance one line after each line is printed.

Bit 0 - STB: Inverse of the STB# pin. This pin controls the data strobe signal to the printer.

(4) EPP Address Port (Base Address 1 + 03h)

The EPP Address Port is only available in the EPP mode. When the Host writes to this port, the contents of D0 -D7 are buffered and output to PD0 - PD7. The leading edge of IOW (Internal signal, active when LPC I/O WRITE cycle is on this address) causes an EPP ADDRESS WRITE cycle. When the Host reads from this port, the contents of PD0 - PD7 are read. The leading edge of IOR (Internal signal, active when LPC I/O READ cycle is on this address) causes an EPP ADDRESS READ cycle.

(5) EPP Data Ports 0-3 (Base Address 1 + 04-07h)

The EPP Data Ports are only available in the EPP mode. When the Host writes to these ports, the contents of D0 - D7 are buffered and output to PD0 - PD7. The leading edge of IOW (Internal signal, active when LPC I/O WRITE cycle is on this address) causes an EPP DATA WRITE cycle. When the Host reads from these ports, the contents of PD0 - PD7 are read. The leading edge of IOR (Internal signal, active when LPC I/O READ cycle is on this address) causes an EPP DATA READ cycle.

9.9.2 EPP Mode Operation

When the parallel port of the IT8722F is set in the EPP mode, the SPP mode is also available. If no EPP Address/Data Port address is decoded (Base address + 03h- 07h), the PD bus is in the SPP mode, and the output signals such as STB#, AFD#, INIT#, and SLIN# are set by the SPP control port. The direction of the data port is controlled by bit 5 of the control port register. There is a 10-msec time required to prevent the system from lockup. The time has elapsed from the beginning of the IOCHRDY (Internal signal: When active, the IT8722F will issue Long Wait in SYNC field) high (EPP READ/WRITE cycle) to WAIT# being de-asserted. If a time-out occurs, the current EPP READ/WRITE cycle is aborted and a logic "1" will be read in bit 0 of the status port register. The Host must write 0 to bit 0, 1, 3 of the control port register before any EPP READ/WRITE cycle (EPP spec.). The pins STB#, AFD# and SLIN# are controlled by hardware for the hardware handshaking during EPP READ/WRITE cycle.

(1) EPP ADDRESS WRITE

1. The Host writes a byte to the EPP Address Port (Base address + 03h). The chip drives D0 - D7 onto PD0 - PD7.
2. The chip asserts WRITE# (STB#) and ASTB# (SLIN#) after IOW becomes active.
3. The peripheral de-asserts WAIT#, indicating that the chip may begin the termination of this cycle. Then, the chip de-asserts ASTB#, latches the address from D0 - D7 to PD bus, allowing the Host to complete the I/O WRITE cycle.
4. The peripheral asserts WAIT#, indicating that it acknowledges the termination of the cycle. Then, the chip de-asserts WRITE to terminate the cycle.

(2) EPP ADDRESS READ

1. The Host reads a byte from the EPP Address Port. The chip drives PD bus to a tri-state for the peripheral to drive.
2. The chip asserts ASTB# after IOR becomes active.
3. The peripheral drives the PD bus valid and de-asserts WAIT#, indicating that the chip may begin the termination of this cycle. Then, the chip de-asserts ASTB#, latches the address from PD bus to D0 -D7, allowing the Host to complete the I/O READ cycle.
4. The peripheral drives the PD bus to a tri-state and then asserts WAIT#, indicating that it acknowledges the termination of the cycle.

(3) EPP DATA WRITE

1. The host writes a byte to the EPP Data Port (Base address +04H - 07H). The chip drives D0- D7 onto PD0 -PD7.
2. The chip asserts WRITE# (STB#) and DSTB# (AFD#) after IOW becomes active.
3. The peripheral de-asserts WAIT#, indicating that the chip may begin the termination of this cycle. Then, the chip de-asserts DSTB#, latches the data from D0 - D7 to the PD bus, allowing the Host to complete the I/O WRITE cycle.
4. The peripheral asserts WAIT#, indicating that it acknowledges the termination of the cycle. Then the chip de-asserts WRITE to terminate the cycle.

(4) EPP DATA READ

1. The Host reads a byte from the EPP DATA Port. The chip drives PD bus to tri-state for the peripheral to drive.
2. The chip asserts DSTB# after IOR becomes active.
3. The peripheral drives PD bus valid and de-asserts WAIT#, indicating that the chip may begin the termination of this cycle. Then, the chip de-asserts DSTB#, latches the data from PD bus to D0 - D7, allowing the host to complete the I/O READ cycle.
4. The peripheral tri-states the PD bus and then asserts WAIT#, indicating that it acknowledges the termination of the cycle.

9.9.3 ECP Mode Operation

This mode is both software and hardware compatible with the existing parallel ports, allowing ECP to be used as a standard LPT port when the ECP mode is not required. It provides an automatic high-burst-bandwidth channel that supports DMA or the ECP mode in both forward and reverse directions. A 16-byte FIFO is implemented in both forward and reverse directions to smooth data flow and enhance the maximum bandwidth requirement allowed. The port supports automatic handshaking for the standard parallel port to improve compatibility and expedite the mode transfer. It also supports run-length encoded (RLE) decompression in hardware. Compression is accomplished by counting identical bytes and transmitting an RLE byte that indicates how many times a byte has been repeated. The IT8722F does not support hardware RLE compression. For a detailed description, please refer to "Extended Capabilities Port Protocol and ISA Interface Standard".

Table 9-41. Bit Map of the ECP Registers

Register	D7	D6	D5	D4	D3	D2	D1	D0
data	PD7	PD6	PD5	PD4	PD3	PD2	PD1	PD0
ecpAFifo	Addr/RLE	Address or RLE field						
dcr	nBusy	nAck	PError	Select	nFault	1	1	1
dcr	1	1	PDDIR	IRQE	SelectIn	nInIt	AutoFd	Strobe
cFifo	Parallel Port Data FIFO							
ecpDFifo	ECP Data FIFO							
tFifo	Test FIFO							
cnfgA	0	0	0	1	0	0	0	0
cnfgB	0	intrValue	0	0	0	0	0	0
ecr	mode			nErrIntrEn	dmaEn	ServiceIntr	full	empty

(1) ECP Register Definitions
Table 9-42. ECP Register Definitions

Name	Address	I/O	ECP Mode	Function
data	Base 1 +000H	R/W	000-001	Data Register
ecpAFifo	Base 1 +000H	R/W	011	ECP FIFO (Address)
dsr	Base 1 +001H	R/W	All	Status Register
dcr	Base 1 +002H	R/W	All	Control Register
cFifo	Base 2 +000H	R/W	010	Parallel Port Data FIFO
ecpDFifo	Base 2 +000H	R/W	011	ECP FIFO (DATA)
tFifo	Base 2 +000H	R/W	110	Test FIFO
cnfgA	Base 2 +000H	R	111	Configuration Register A
cnfgB	Base 2 +001H	R/W	111	Configuration Register B
ecr	Base 2 +002H	R/W	All	Extended Control Register

Note 1: The Base address 1 depends on the Logical Device configuration registers of Parallel Port (0X60,0X61).

Note 2: The Base address 2 depends on the Logical Device configuration registers of Parallel Port (0X62,0X63).

(2) ECP Mode Descriptions
Table 9-43. ECP Mode Descriptions

Mode	Description
000	Standard Parallel Port Mode
001	PS/2 Parallel Port Mode
010	Parallel Port FIFO Mode
011	ECP Parallel Port Mode
110	Test Mode
111	Configuration Mode

Note: Please refer to the ECP Register Description on page 128 and 129 for a detailed description of the mode selection.

(3) ECP Pin Descriptions**Table 9-44. ECP Pin Descriptions**

Name	Type	Description
nStrobe (HostClk)	O	Used for handshaking with Busy to write data and addresses into the peripheral device.
PD0-PD7	I/O	Address, data or RLE data.
nAck (PeriphClk)	I	Used for handshaking with nAutoFd to transfer data from the peripheral device to the Host.
Busy (PeriphACK)	I	The peripheral uses this signal for flow control in the forward direction (handshaking with nStrobe). In the reverse direction, this signal is used to determine whether a command or data information is present on PD0-PD7.
PError (nAckReverse)	I	Used to acknowledge nInit from the peripheral which drives this signal low, allowing the host to drive the PD bus.
Select	I	Printer On-Line Indication.
nAutoFd (HostAck)	O	In the reverse direction, it is used for handshaking between the nAck and the Host. When it is asserted, a peripheral data byte is requested. In the forward direction, this signal is used to determine whether a command or data information is present on PD0 - PD7.
nFault (nPeriphRequest)	I	In the forward direction (only), the peripheral is allowed (but not required) to assert this signal (low) to request a reverse transfer in the ECP mode. The signal provides a mechanism for peer-to-peer communication. It is typically used to generate an interrupt to the host, which has the ultimate control over the transfer direction.
nInit (nReverseRequest)	O	The host may drive this signal low to place the PD bus in the reverse direction. In the ECP mode, the peripheral is permitted to drive the PD bus when nInit is low, and nSelectIn is high.
NSelectIn (1284 Active)	O	Always inactive (high) in the ECP mode.

(4) Data Port (Base 1+00h, Modes 000 and 001)

Its contents will be cleared by a reset. In a WRITE operation, the contents of the LPC data fields are latched by Data Register. The contents are then sent without being inverted to PD0-PD7. In a READ operation, the contents of data ports are read and sent to the host.

(5) ecpAFifo Port (Address/RLE) (Base 1 +00h, Mode 011)

Any data byte written to this port is placed in the FIFO and tagged as an ECP Address/RLE. The hardware then automatically sends this data to the peripheral. The operation of this port is valid only in the forward direction (dcr(5)=0).

(6) Device Status Register (dsr) (Base 1 +01h, Mode All)

Bit 0, 1 and 2 of this register are not implemented. These bit states are remained high in a READ operation of the Printer Status Register.

dsr(7): This bit is the inverted level of the Busy input.

dsr(6): This bit is the state of the nAck input.

dsr(5): This bit is the state of the PError input.

dsr(4): This bit is the state of the Select input.

dsr(3): This bit is the state of the nFault input.

dsr(2)-dsr(0): These bits are always 1.

(7) Device Control Register (dcr) (Base 1+02h, Mode All)

Bit 6 and 7 of this register have no function. They are set high during the READ operation, and cannot be written. Contents in bits 0 to 5 are initialized to 0 when the RESET pin is active.

dcr(7)-dcr(6): These two bits are always high.

dcr(5): Except in the modes 000 and 010, setting this bit low means that the PD bus is in output operation; setting it high, in input operation. This bit will be forced to low in mode 000.

dcr(4): Setting this bit high enables the interrupt request from the peripheral to the host due to a rising edge of the nAck input.

dcr(3): It is inverted and output to SelectIn.

dcr(2): It is output to nInIt without inversion.

dcr(1): It is inverted and output to nAutoFd.

dcr(0): It is inverted and output to nStrobe.

(8) Parallel Port Data FIFO (cFifo) (Base 2+00h, Mode 010)

Bytes written or DMA transferred from the Host to this FIFO are sent by hardware handshaking to the peripheral according to the Standard Parallel Port protocol. This operation is only defined for the forward direction.

(9) ECP Data FIFO (ecpDFifo) (Base 2+00h, Mode 011)

When the direction bit dcr(5) is 0, bytes written or DMA transferred from the Host to this FIFO are sent by hardware handshaking to the peripheral according to the ECP parallel port protocol. When dcr(5) is 1, data bytes from the peripheral to this FIFO are read in an automatic hardware handshaking. The Host can receive these bytes by performing READ operations or DMA transfers from this FIFO.

(10) Test FIFO (tFifo) (Base 2+00h, Mode 110)

The host may operate READ/WRITE or DMA transfers to this FIFO in any directions. Data in this FIFO will be displayed on the PD bus without using hardware protocol handshaking. The tFifo will not accept new data after it is full. Making a READ from an empty tFifo causes the last data byte to return.

(11) Configuration Register A (cnfgA) (Base 2+00h, Mode 111)

This **read only** register indicates to the system that interrupts are ISA-Pulses compatible. This is an 8-bit implementation by returning a 10h.

(12) Configuration Register B (cnfgB) (Base 2+01h, Mode 111)

This register is **read only**.

cnfgB(7): A logic "0" read indicates that the chip does not support hardware RLE compression.

cnfgB(6): Reserved.

cnfgB(5)-cnfgB(3): A value 000 read indicates that the interrupt must be selected with jumpers.

cnfgB(2)-cnfgB(0): A value 000 read indicates that the DMA channel is jumpered 8-bit DMA.

(13) Extended Control Register (ecr) (Base 2+02h, Mode All)

ECP function control register.

ecr(7)-ecr(5): These bits are used for READ/WRITE and mode selection.

Table 9-45. Extended Control Register (ECR) Mode and Description

ECR	Mode and Description
000	Standard Parallel Port Mode. The FIFO is reset and the direction bit dcr(5) is always 0 (forward direction) in this mode.
001	PS/2 Parallel Port Mode. It is similar to the SPP mode, except that the dcr(5) is read/write . When dcr(5) is 1, the PD bus is tri-state. Reading the data port returns the value on the PD bus instead of the value of the data register.
010	Parallel Port Data FIFO Mode. This mode is similar to the 000 mode, except that the Host writes or DMA transfers the data bytes to the FIFO. The FIFO data are then transmitted to the peripheral using the standard parallel port protocol automatically. This mode is only valid in the forward direction (dcr(5)=0).
011	ECP Parallel Port Mode. In the forward direction, bytes placed into the ecpDFifo and ecpAFifo are placed in a single FIFO and automatically transmitted to the peripheral under the ECP protocol. In the reverse direction, bytes are transmitted to the ecpDFifo from the ECP port.
100, 101	Reserved, not defined.
110	Test mode. In this mode, the FIFO may be read from or written to, but it cannot be sent to the peripheral.
111	Configuration mode. In this mode, the cnfgA and cnfgB registers are accessible at 0x400 and 0x401.

ecr(4): nErrIntrEn, READ/WRITE, Valid in ECP(011) Mode

1: Disables the interrupt generated on the asserting edge of the nFault input.

0: Enables the interrupt pulse on the asserting edge of the nFault. An interrupt pulse will be generated if nFault is asserted, or if this bit is written from 1 to 0 in the low-level nFault.

ecr(3): dmaEn, READ/WRITE

1: Enables DMA. DMA starts when serviceIntr (ecr(2)) is 0.

0: Disables DMA unconditionally.

ecr(2): ServiceIntr, READ/WRITE

1: Disables DMA and all service interrupts.

0: Enables the service interrupts. This bit will be set to "1" by hardware when one of the three service interrupts has occurred.

Writing "1" to this bit will not generate an interrupt.

Case 1: dmaEn=1

During DMA, this bit is set to 1 (a service interrupt generated) if the terminal count is reached.

Case 2: dmaEn=0, dcr(5)=0

This bit is set to 1 (a service interrupt generated) whenever there are writeIntrThreshold or more bytes space free in the FIFO.

Case 3: dmaEn=0, dcr(5)=1

This bit is set to 1 (a service interrupt generated) whenever there are readIntrThreshold or more valid bytes to be read from the FIFO.

ecr(1): full, **read only**

1: The FIFO is full and cannot accept another byte.

0: The FIFO has at least 1 free data byte space.

ecr(0): empty, **read only**

1: The FIFO is empty.

0: The FIFO contains at least 1 data byte.

(14) Mode Switching Operation

In programmed I/O control (mode 000 or 001), P1284 negotiation and all other tasks that happen before data transmission are software-controlled. Setting mode to 011 or 010 will cause the hardware to perform an automatic control-line handshaking, transferring information between the FIFO and the ECP port.

From the mode 000 or 001, any other mode may be immediately switched to any other mode. To change direction, the mode must first be set to 001.

In the extended forward mode, the FIFO must be cleared and all the signals must be de-asserted before returning to mode 000 or 001. In ECP reverse mode, all data must be read from the FIFO before returning to mode 000 or 001. Usually, unneeded data are accumulated during ECP reverse handshaking when the mode is changed during a data transfer. In such conditions, nAutoFd will be de-asserted regardless of the transfer state. To avoid bugs during handshaking signals, these guidelines must be followed.

(15) Software Operation (ECP)

Before the ECP operation can begin, it is the first necessity for the Host to switch the mode to 000 in order to negotiate with the parallel port. During this process, the Host determines whether the peripheral supports the ECP protocol.

After this negotiation is completed, the mode is set to 011 (ECP). To enable the drivers, the direction must be set to 0. Both strobe and autoFd are set to 0, causing nStrobe and nAutoFd signals to be de-asserted.

All FIFO data transfers are PWord wide and PWord aligned. Permitted only in the forward direction, Address/RLE transfers are byte-wide. The ECP Address/RLE bytes may be automatically sent by writing to the ecpAFifo. Similarly, data PWords may be automatically sent via the ecpDFifo.

To change directions, the Host switches mode to 001. It then negotiates either the forward or reverse channel, sets the direction to 1 or 0 and finally switches mode to 001. If the direction is set to 1, the hardware performs the handshaking for each ECP data byte read then tries to fill the FIFO. At this time, PWords may be read from the ecpDFifo while it retains data. It is also possible to perform the ECP transfers by handshaking with individual bytes under programmed control in mode = 001, or 000 even though this is a comparatively time-consuming approach.

(16) Hardware Operation (DMA)

The Standard PC DMA protocol (through LDRQ#) is followed. As in the programmed I/O case, software sets the direction and state. Next, the desired count and memory addresses are programmed into the DMA controller. The dmaEn is set to 1, and the serviceIntr is set to 0. To complete the process, the DMA channel with the DMA controller is unmasked. The contents in the FIFO are emptied or filled by DMA using the right mode and direction.

DMA is always transferred to or from the FIFO located at 0 x 400. By generating an interrupt and asserting a serviceIntr, DMA is disabled when the DMA controller reaches the terminal count. By not asserting LDRQ# for more than 32 consecutive DMA cycles, blocking of refresh requests is eliminated.

When it is necessary to disable DMA while a transfer is perform, the host DMA controller is disabled, serviceIntr is et to 1, and then dmaEn is set to 0. If the contents in the FIFO are empty or full, the DMA will start again. This is first done by enabling the host DMA controller, and then setting dmaEn to 1. Finally, serviceIntr is set to 0. Upon completion of a DMA transfer in the forward direction, the software program must wait until the contents in the FIFO are empty and the busy line is low, ensuring that all data successfully reach the peripheral device.

(17) Interrupts

It is necessary to generate an interrupt when any of the following states is reached.

1. serviceIntr = 0, dmaEn = 0, direction = 0, and the number of PWords in the FIFO is greater than or equal to writeIntrThreshold.

2. serviceIntr = 0, dmaEn = 0, direction = 1, and the number of PWords in the FIFO is greater than or equal to readIntrThreshold.
3. serviceIntr = 0, dmaEn = 1, and DMA reaches the terminal count.
4. nErrIntrEn = 0 and nFault goes from high to low or when nErrIntrEn is set from 1 to 0 and nFault is asserted.
5. ackIntEn = 1. In current implementations of using existing parallel ports, the interrupt generated may be either edge or level trigger type.

(18) Interrupt Driven Programmed I/O

It is also possible to use an interrupt-driven programmed I/O to execute either ECP or parallel port FIFOs. An interrupt will occur in the forward direction when serviceIntr is 0 and the number of free PWords in the FIFO is equal to or greater than writeIntrThreshold. If either of these conditions is not met, it may be filled with writeIntrThreshold PWords. An interrupt will occur in the reverse direction when serviceIntr is 0 and the number of available PWords in the FIFO is equal to readIntrThreshold. If it is full, the FIFO can be completely emptied in a single burst. If it is not full, only a number of PWords equal to readIntrThreshold may be read from the FIFO in a single burst. In the Test mode, software can determine the values of writeIntrThreshold, readIntrThreshold, and FIFO depth while accessing the FIFO.

Any PC LPC bus implementation that is adjusted to expedite DMA or I/O transfer must ensure that the bandwidth on the ISA is maintained on the interface. Although the LPC (even PCI) bus of PC cannot be directly controlled, the interface bandwidth of ECP port can be constrained to perform at the optimum speed.

(19) Standard Parallel Port

In the forward direction with DMA, the standard parallel port is run at or close to the permitted peak bandwidth of 500 KB/sec. The state machine does not examine nAck, but just begins the next DMA based on the Busy signal.

9.10 Keyboard Controller (KBC)

The keyboard controller is implemented using an 8-bit microcontroller that is capable of executing the 8042 instruction set. For general information, please refer to the description of the 8042 in the 8-bit controller handbook. In addition, the microcontroller can enter a power-down mode by executing two types of power-down instructions. The 8-bit microcontroller has 256 bytes of RAM for data memory and 2 Kbytes of ROM for the program storage.

The ROM codes may come from various vendors (or users) and are programmed during the manufacturing process. To assist in developing ROM codes, the keyboard controller has an external access mode. In the external access mode, the internal ROM is disabled and the instructions executed by the microcontroller come from an externally connected ROM.

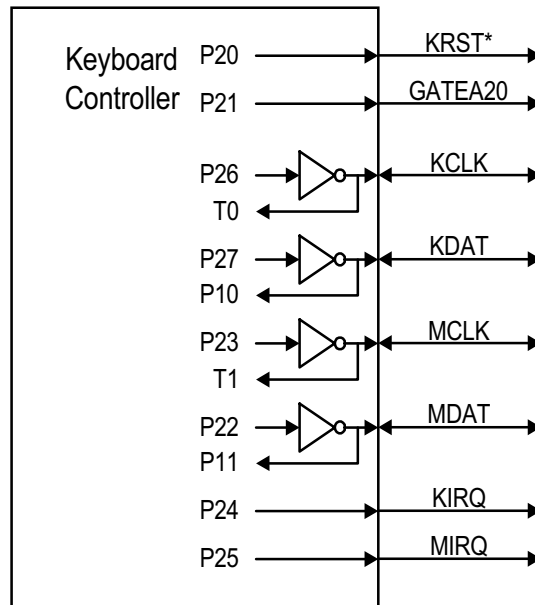

Figure 9-10. Keyboard and Mouse Interface

9.10.1 Host Interface

The keyboard controller interfaces with the system through the 8042 style host interface. The table 10-45 shows how the interface decodes the control signals.

Table 9-46. Data Register READ/WRITE Controls

Host Address ^{Note}	R/W*	Function
60h	R	READ DATA
60h	W	WRITE DATA, (Clear F1)
64h	R	READ Status
64h	W	WRITE Command, (set F1)

Note: These are the default values of the LDN5, 60h and 61h (DATA); LDN5, 62h and 63h (Command). All these registers are programmable.

READ DATA: This is an 8-bit **read only** register. When read, the KIRQ output and OBF flag in the status register are cleared.

WRITE DATA: This is an 8-bit **write only** register. When written, the F1 flag of the Status register is cleared and the IBF bit is set.

READ Status: This is an 8-bit **read only** register. Refer to the description of the Status register for more information.

WRITE Command: This is an 8-bit **write only** register. When written, both F1 and IBF flags of the Status register are set.

9.10.2 Data Registers and Status Register

The keyboard controller provides two data registers: one is DBIN for data input, and the other is DBOUT for data output. Each of the data registers is 8-bit wide. A write (microcontroller) to the DBOUT will load Keyboard Data Read Buffer, set OBF flag and set the KIRQ output. A read (microcontroller) of the DBIN will read the data from the Keyboard Data or Command Write Buffer and clear the IBF flag.

The status register holds information concerning the status of the data registers, the internal flags, and some user-defined status bits. Please refer to Table 10-46. Bit 0 OBF is set to “1” when the microcontroller writes data into DBOUT, and is cleared when the system initiates a DATA READ operation. Bit 1 IBF is set to “1” when the system initiates a WRITE operation, and is cleared when the microcontroller executes an “IN A, DBB” instruction. The F0 and F1 flags can be set or reset when the microcontroller executes the clear and complement flag instructions. F1 also holds the system WRITE information when the system performs the WRITE operations.

Table 9-47. Status Register

7	6	5	4	3	2	1	0
ST7	ST6	ST5	ST4	F1	F0	IBF	OBF

9.10.3 Keyboard and Mouse Interface

KCLK is the keyboard clock pin. Its output is the inversion of pin P26 of the microcontroller, and the input of KCLK is connected to the T0 pin of the microcontroller. KDAT is the keyboard data pin; its output is the inversion of pin P27 of the microcontroller, and the input of KDAT is connected to the P10 of the microcontroller. MCLK is the mouse clock pin; its output is the inversion of pin P23 of the microcontroller, and the input of MCLK is connected to the T1 pin of the microcontroller. MDAT is the Mouse data pin; its output is the inversion of pin P22 of the microcontroller, and the input of MDAT is connected to the P11 of the microcontroller. KRST# is pin P20 of the microcontroller. GATEA20 is the pin P21 of the microcontroller. These two pins are used as software controlled or user defined outputs. External pull-ups may be required for these pins.

9.10.4 KIRQ and MIRQ

KIRQ is the interrupt request for keyboard (Default IRQ1), and MIRQ is the interrupt request for mouse (Default IRQ12). KIRQ is internally connected to P24 pin of the microcontroller, and MIRQ is internally connected to pin P25 of the microcontroller.

9.11 Consumer Remote Control (TV Remote) IR (CIR)

9.11.1 Overview

The CIR is used in Consumer Remote Control equipment and is a programmable amplitude shift keyed (ASK) serial communication protocol. By adjusting frequencies, baud rate divisors and sensitivity ranges, the CIR registers are able to support the popular protocols such as RC-5, NEC and RECS-80. Software driver programming can support new protocols.

9.11.2 Features

- Supports 30 kHz – 57 kHz (low frequency) or 400 kHz – 500 kHz (high frequency) carrier transmission
- Baud rate up to 115200 BPS (high frequency)
- Demodulation optional
- Supports transmission run-length encoding and deferral functions
- 32-byte FIFO for data transmission or reception

9.11.3 Block Diagram

The CIR consists of the Transmitter and Receiver parts. The Transmitter part is responsible for transmitting data to the FIFO, processing the FIFO data by serialization, modulation and sending out the data through the LED device. The Receiver part is responsible for receiving data, processing data by demodulation, deserialization and storing data in the Receiver FIFO.

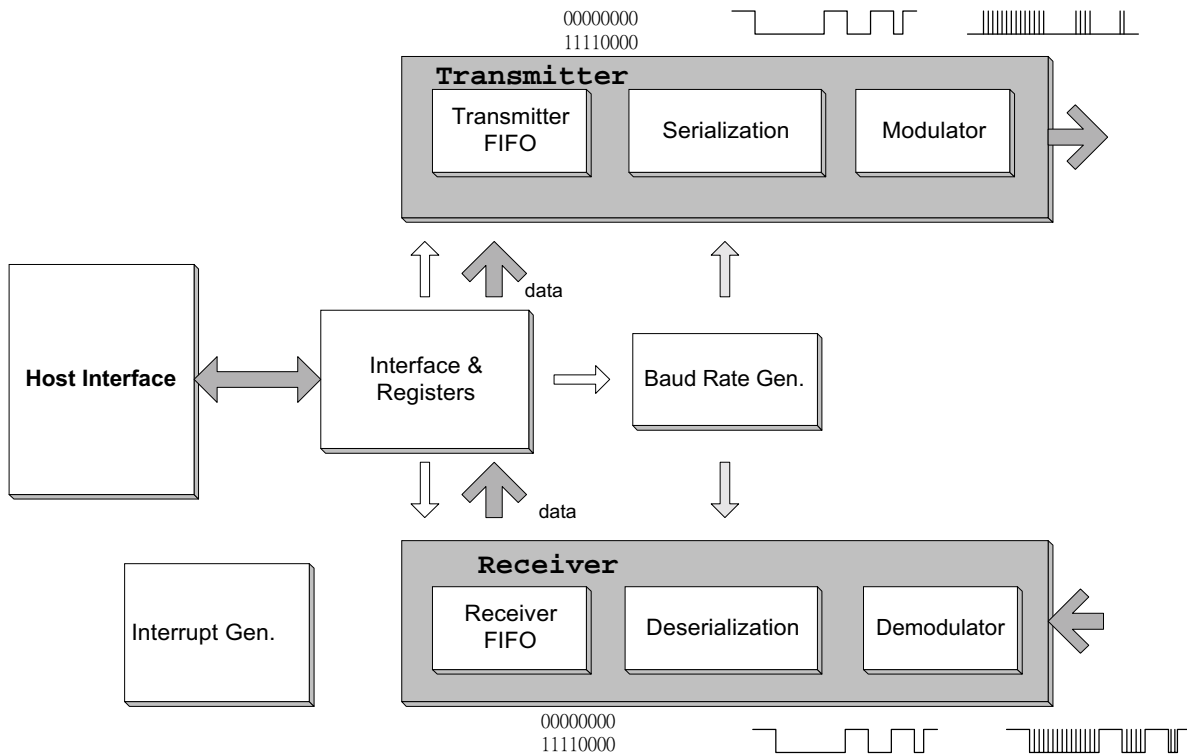

Figure 9-11. CIR Block Diagram

9.11.4 Transmit Operation

The data written to the Transmitter FIFO will be exactly serialized from LSB to MSB, modulated with carrier frequency and sent to the CIRTX output. The data are either in bit-string format or run-length decode.

Before the data transmission can begin, code byte write operations must be performed to the Transmitter FIFO DR. The bit TXRLE in the TCR1 should be set to “1” before the run-length decode data can be written into the Transmitter FIFO. Set TXENDF in the TCR1 will enable the data transmission deferral and avoid the transmitter FIFO underrun. The bit width of the serialized bit string is determined by the value programmed in the baud rate divisor registers BDLR and BDHR. When the bits HCFS and CFQ[4:0] are set, either the high-speed or low-speed carrier range is selected, and the corresponding carrier frequency will also be determined. Bits TXMPM[1:0] and TXMPW[2:0] specify the pulse numbers in a bit width and the required duty cycles of the carrier pulse according to the communication protocol. Only a logic “0” can activate the Transmitter LED in the format of a series of modulating pulses.

9.11.5 Receive Operation

The Receiver function is enabled if the bit RXEN in the RCR is set to “1”. Either demodulated or modulated RX# signal is loaded into the Receiver FIFO, and the bit RXEND in the RCR determines whether the demodulation logic should be used or not. Determine the baud rate by programming the baud rate divisor registers BDLR and BDHR, and the carrier frequencies by programming the bits HCFS and CFQ [4:0]. Set RDWOS to “0” to sync. The bit RXACT in the RCR is set to “1” when the serial data or the selected carrier is incoming and the sampled data will then be kept in the Receiver FIFO. Write “1” to the bit RXACT to stop the Receiver operation; “0” to the bit RXEN to disable the Receiver.

9.11.6 Register Descriptions and Address

Table 9-48. List of CIR Registers

Address	R/W	Default	Name
Base + 0h	R/W	FFh	CIR Data Register (DR)
Base + 1h	R/W	00h	CIR Interrupt Enable Register (IER)
Base + 2h	R/W	01h	CIR Receiver Control Register (RCR)
Base + 3h	R/W	00h	CIR Transmitter Control Register 1 (TCR1)
Base + 4h	R/W	5Ch	CIR Transmitter Control Register 2 (TCR2)
Base + 5h	R	00h	CIR Transmitter Status Register (TSR)
Base + 6h	R	00h	CIR Receiver Status Register (RSR)
Base + 5h	R/W	00h	CIR Baud Rate Divisor Low Byte Register (BDLR)
Base + 6h	R/W	00h	CIR Baud Rate Divisor High Byte Register (BDHR)
Base + 7h	R/W	01h	CIR Interrupt Identification Register (IIR)

9.11.6.1 CIR Data Register (DR)

The DR, an 8-bit **read/write** register, is the data port for CIR. Data are transmitted and received through this register.

Address: Base address + 0h

Bit	R/W	Default	Description
7 – 0	R/W	FFh	CIR Data Register (DR[7:0]) Writing data to this register causes data to be written to the Transmitter FIFO. Reading data from this register causes data to be received from the Receiver FIFO.

9.11.6.2 CIR Interrupt Enable Register (IER)

The IER, an 8-bit **read/write** register, is used to enable the CIR interrupt request.

Address: Base address + 1h

Bit	R/W	Default	Description
7 – 6	-	-	Reserved for ITE use.
5	R/W	0b	RESET (RESET) This bit is a software reset function. Writing a “1” to this bit resets the registers of DR, IER, TCR1, BDLR, BDHR and IIR. This bit is then cleared to initial value automatically.
4	R/W	0b	Baud Rate Register Enable Function Enable (BR) This bit is used to control the baud rate registers enable read/write function. Set this bit to “1” to enable the baud rate registers for CIR. Set this bit to “0” to disable the baud rate registers for CIR.
3	R/W	0b	Interrupt Enable Function Control (IEC) This bit is used to control the interrupt enable function. Set this bit to “1” to enable the interrupt request for CIR. Set this bit to “0” to disable the interrupt request for CIR.
2	R/W	0b	Receiver FIFO Overrun Interrupt Enable (RFOIE) This bit is used to control Receiver FIFO Overrun Interrupt request. Set this bit to “1” to enable Receiver FIFO Overrun Interrupt request. Set this bit to “0” to disable Receiver FIFO Overrun Interrupt request.
1	R/W	0b	Receiver Data Available Interrupt Enable (RDAIE) This bit is used to enable Receiver Data Available Interrupt request. The Receiver will generate this interrupt when the data available in the FIFO exceed the FIFO threshold level. Set this bit to “1” to enable Receiver Data Available Interrupt request. Set this bit to “0” to disable Receiver Data Available Interrupt request.
0	R/W	0b	Transmitter Low Data Level Interrupt Enable (TLDLIE) This bit is used to enable Transmitter Low Data Level Interrupt request. The Transmitter will generate this interrupt when the data available in the FIFO are less than the FIFO threshold Level. Set this bit to “1” to enable Transmitter Low Data Level Interrupt request. Set this bit to “0” to disable Transmitter Low Data Level Interrupt request.

9.11.6.3 CIR Receiver Control Register (RCR)

The RCR, an 8-bit **read/write** register, is used to control the CIR Receiver.

Address: Base address + 2h

Bit	R/W	Default	Description
7	R/W	0b	Receiver Data Without Sync. (RDWOS) This bit is used to control the sync. logic for receiving data. Set this bit to "1" to obtain the receiving data without sync. logic. Set this bit to "0" to obtain the receiving data in sync. logic.
6	R/W	0b	High-Speed Carrier Frequency Select (HCFS) This bit is used to select Carrier Frequency between high-speed and low-speed. 0:30-58 kHz (Default) 1:400-500 kHz
5	R/W	0b	Receiver Enable (RXEN) This bit is used to enable the Receiver function. Enable Receiver and the RXACT will be active if the selected carrier frequency is received. Set this bit to "1" to enable the Receiver function. Set this bit to "0" to disable the Receiver function.
4	R/W	0b	Receiver Demodulation Enable (RXEND) This bit is used to control the Receiver Demodulation logic. If the Receiver device cannot demodulate the correct carrier, set this bit to "1". Set this bit to "1" to enable Receiver Demodulation logic. Set this bit to "0" to disable Receiver Demodulation logic.
3	R/W	0b	Receiver Active (RXACT) This bit is used to control the Receiver operation. This bit is set to "0" when the Receiver is inactive. This bit is set to "1" when the Receiver detects a pulse (RXEND=0) or pulse-train (RXEND=1) with correct carrier frequency. The Receiver then starts to sample the input data when Receiver Active is set. Write a "1" to this bit to clear the Receiver Active condition and make the Receiver enter the inactive mode.
2-0	R/W	001b	Receiver Demodulation Carrier Range (RXDCR[2:0]) These three bits are used to set the tolerance of the Receiver. Demodulation carrier frequency. See Table 10-49 and Table 10-50.

9.11.6.4 CIR Transmitter Control Register 1 (TCR1)

The TCR1, an 8-bit **read/write** register, is used to control the Transmitter.

Address: Base address + 3h

Bit	R/W	Default	Description															
7	R/W	0b	FIFO Clear (FIFOCLR) Writing a "1" to this bit clears the FIFO. This bit is then cleared to "0" automatically.															
6	R/W	0b	Internal Loopback Enable (ILE) This bit is used to execute internal loopback for test and must be "0" in normal operation. Set this bit to "0" to disable the Internal Loopback mode. Set this bit to "1" to enable the Internal Loopback mode.															
5 - 4	R/W	0b	FIFO Threshold Level (FIFOTL) These two bits are used to set the FIFO Threshold Level. The FIFO length is 32 bytes for TX or RX function (ILE = 0) in normal operation and 16 bytes for both TX and RX in internal Loopback mode (ILE = 1). <table border="1" style="margin-left: auto; margin-right: auto;"> <thead> <tr> <th></th> <th>16-Byte Mode</th> <th>32-Byte Mode</th> </tr> </thead> <tbody> <tr> <td>00</td> <td>1</td> <td>1 (Default)</td> </tr> <tr> <td>01</td> <td>3</td> <td>7</td> </tr> <tr> <td>10</td> <td>7</td> <td>17</td> </tr> <tr> <td>11</td> <td>13</td> <td>25</td> </tr> </tbody> </table>		16-Byte Mode	32-Byte Mode	00	1	1 (Default)	01	3	7	10	7	17	11	13	25
	16-Byte Mode	32-Byte Mode																
00	1	1 (Default)																
01	3	7																
10	7	17																
11	13	25																
3	R/W	0b	Transmitter Run Length Enable (TXRLE) This bit controls the Transmitter Run Length encoding/decoding mode, which condenses a series of "1" or "0" into one byte with the bit value stored in bit 7 and number of bits minus 1 in bits 6 – 0. Set this bit to "1" to enable the Transmitter Run Length mode. Set this bit to "0" to disable the Transmitter Run Length mode.															
2	R/W	0b	Transmitter Deferral (TXENDF) This bit is used to avoid Transmitter underrun condition. When this bit is set to "1", the Transmitter FIFO data will be kept until the transmitter time-out condition occurs, or the FIFO becomes full.															
1 – 0	R/W	0b	Transmitter Modulation Pulse Mode (TXMPM[1:0]) These two bits are used to define the Transmitter modulation pulse mode. TXMPM[1:0] Modulation Pulse Mode C_pls mode (Default): Pulses are generated continuously for the entire logic 0 bit time. 8_pls mode: 8 pulses are generated for each logic 0 bit. 6_pls mode: 6 pulses are generated for each logic 0 bit. 11: Reserved.															

9.11.6.5 CIR Transmitter Control Register (TCR2)

The TCR2, an 8-bit **read/write** register, is used to determine the carrier frequency.

Address: Base address + 4h

Bit	R/W	Default	Description																											
7 – 3	R/W	01011b	Carrier Frequency (CFQ[4:0]) These five bits are used to determine the modulation carrier frequency. See Table 10-48.																											
2 – 0	R/W	100b	Transmitter Modulation Pulse Width (TXMPW[2:0]) These three bits are used to set the Transmitter Modulation pulse width. The duty cycle of the carrier will be determined according to the settings of Carrier Frequency and the selection of Transmitter Modulation pulse width.																											
			<table border="0" style="width: 100%; border-collapse: collapse;"> <thead> <tr> <th style="text-align: left; width: 30%;">TXMPW[2:0]</th> <th style="text-align: left; width: 35%;">HCFS = 0</th> <th style="text-align: left; width: 35%;">HCFS = 1</th> </tr> </thead> <tbody> <tr> <td>000</td> <td>Reserved</td> <td>Reserved</td> </tr> <tr> <td>001</td> <td>Reserved</td> <td>Reserved</td> </tr> <tr> <td>010</td> <td>6 μs</td> <td>0.7 μs</td> </tr> <tr> <td>011</td> <td>7 μs</td> <td>0.8 μs</td> </tr> <tr> <td>100</td> <td>8.7 μs</td> <td>0.9 μs (Default)</td> </tr> <tr> <td>101</td> <td>10.6 μs</td> <td>1.0 μs</td> </tr> <tr> <td>110</td> <td>13.3 μs</td> <td>1.16 μs</td> </tr> <tr> <td>111</td> <td>Reserved</td> <td>Reserved</td> </tr> </tbody> </table>	TXMPW[2:0]	HCFS = 0	HCFS = 1	000	Reserved	Reserved	001	Reserved	Reserved	010	6 μ s	0.7 μ s	011	7 μ s	0.8 μ s	100	8.7 μs	0.9 μs (Default)	101	10.6 μ s	1.0 μ s	110	13.3 μ s	1.16 μ s	111	Reserved	Reserved
TXMPW[2:0]	HCFS = 0	HCFS = 1																												
000	Reserved	Reserved																												
001	Reserved	Reserved																												
010	6 μ s	0.7 μ s																												
011	7 μ s	0.8 μ s																												
100	8.7 μs	0.9 μs (Default)																												
101	10.6 μ s	1.0 μ s																												
110	13.3 μ s	1.16 μ s																												
111	Reserved	Reserved																												

Table 9-49. Modulation Carrier Frequency

CFQ	Low Frequency (HCFS =0)	High Frequency (HCFS = 1)
00000	27 kHz	-
00010	29 kHz	-
00011	30 kHz	400 kHz
00100	31 kHz	-
00101	32 kHz	-
00110	33 kHz	-
00111	34 kHz	-
01000	35 kHz	450 kHz
01001	36 kHz	-
01010	37 kHz	-
01011	38 kHz (default)	480 kHz (default)
01100	39 kHz	-
01101	40 kHz	500 kHz
01110	41 kHz	-
01111	42 kHz	-
10000	43 kHz	-
10001	44 kHz	-
10010	45 kHz	-
10011	46 kHz	-
10100	47 kHz	-
10101	48 kHz	-
10110	49 kHz	-
10111	50 kHz	-
11000	51 kHz	-
11001	52 kHz	-
11010	53 kHz	-
11011	54 kHz	-
11100	55 kHz	-
11101	56 kHz	-
11110	57 kHz	-
11111	58 kHz	-

Table 9-50. Receiver Demodulation Low Frequency (HCFS = 0)

RXDCR	001		010		011		100		101		110		(Hz)
	CFQ	Min.	Max.	Min.	Max.	Min.	Max.	Min.	Max.	Min.	Max.	Min.	
00001	26.25	29.75	24.5	31.5	22.75	33.25	21	35	19.25	36.75	17.5	38.5	28k
00010	27.19	30.81	25.38	32.63	23.56	34.44	21.75	36.25	19.94	38.06	18.13	39.88	29k
00011	28.13	31.88	26.25	33.75	24.38	35.63	22.5	37.5	20.63	39.38	18.75	41.25	30k
00100	29.06	32.94	27.13	34.88	25.19	36.81	23.25	38.75	21.31	40.69	19.38	42.63	31k
00101	30	34	28	36	26	38	24	40	22	42	20	44	32k
00110	30.94	35.06	28.88	37.13	26.81	39.19	24.75	41.25	22.69	43.31	20.63	45.38	33k
00111	31.88	36.13	29.75	38.25	27.63	40.38	25.5	42.5	23.38	44.63	21.25	46.75	34k
01000	32.81	37.19	30.63	39.38	28.44	41.56	26.25	43.75	24.06	45.94	21.88	48.13	35k
01001	33.75	38.25	31.5	40.5	29.25	42.75	27	45	24.75	47.25	22.5	49.5	36k
01010	34.69	39.31	32.38	41.63	30.06	43.94	27.75	46.25	25.44	48.56	23.13	50.88	37k
01011	35.63	40.38	33.25	42.75	30.88	45.13	28.5	47.5	26.13	49.88	23.75	52.25	38k
01100	36.56	41.44	34.13	43.88	31.69	46.31	29.25	48.75	26.81	51.19	24.38	53.63	39k
01101	37.5	42.5	35	45	32.5	47.5	30	50	27.5	52.5	25	55	40k
01110	38.44	43.56	35.88	46.13	33.31	48.69	30.75	51.25	28.19	53.81	25.63	56.38	41k
01111	39.38	44.63	36.75	47.25	34.13	49.88	31.5	52.5	28.88	55.13	26.25	57.75	42k
10000	40.31	45.69	37.63	48.38	34.94	51.06	32.25	53.75	29.56	56.44	26.88	59.13	43k
10001	41.25	46.75	38.5	49.5	35.75	52.25	33	55	30.25	57.75	27.5	60.5	44k
10010	42.19	47.81	39.38	50.63	36.56	53.44	33.75	56.25	30.94	59.06	28.13	61.88	45k
10011	43.13	48.88	40.25	51.75	37.38	54.63	34.5	57.5	31.63	60.38	28.75	63.25	46k
10100	44.06	49.94	41.13	52.88	38.19	55.81	35.25	58.75	32.31	61.69	29.38	64.63	47k
10101	45	51	42	54	39	57	36	60	33	63	30	66	48k
10110	45.94	52.06	42.88	55.13	39.81	58.19	36.75	61.25	33.69	64.31	30.63	67.38	49k
10111	46.88	53.13	43.75	56.25	40.63	59.38	37.5	62.5	34.38	65.63	31.25	68.75	50k
11000	47.81	54.19	44.63	57.38	41.44	60.56	38.25	63.75	35.06	66.94	31.88	70.13	51k
11001	49.18	54.55	46.88	57.69	44.78	61.22	42.86	65.22	41.1	69.77	39.47	75	52k
11010	49.69	56.31	46.38	59.63	43.06	62.94	39.75	66.25	36.44	69.56	33.13	72.88	53k
11011	50.63	57.38	47.25	60.75	43.88	64.13	40.5	67.5	37.13	70.88	33.75	74.25	54k
11100	51.56	58.44	48.13	61.88	44.69	65.31	41.25	68.75	37.81	72.19	34.38	75.63	55k
11101	52.5	59.5	49	63	45.5	66.5	42	70	38.5	73.5	35	77	56k
11110	53.44	60.56	49.88	64.13	46.31	67.69	42.75	71.25	39.19	74.81	35.63	78.38	57k

Table 9-51. Receiver Demodulation High Frequency (HCFS = 1)

RXDCR	001		010		011		100		101		110		(Hz)
	Min.	Max.	Min.	Max.	Min.	Max.	Min.	Max.	Min.	Max.	Min.	Max.	
00011	375	425	350	450	325	475	300	500	275	525	250	550	400k
01000	421.9	478.1	393.8	506.3	365.6	534.4	337.5	562.5	309.4	590.6	281.3	618.8	450k
01011	450	510	420	540	390	570	360	600	330	630	300	660	480k
01011	468.8	531.3	437.5	562.5	406.3	593.8	375	625	343.8	656.3	312.5	687.5	500k

9.11.6.6 CIR Baud Rate Divisor Low Byte Register (BDLR)

The BDLR, an 8-bit **read/write** register, is used to program the CIR Baud Rate clock.

Address: Base address + 5h (when BR = 1)

Bit	R/W	Default	Description
7-0	R/W	00h	Baud Rate Divisor Low Byte (BDLR[7:0]) These bits are the low byte of the register used to divide the Baud Rate clock.

9.11.6.7 CIR Baud Rate Divisor High Byte Register (BDHR)

The BDHR, an 8-bit **read/write** register, is used to program the CIR Baud Rate clock.

Address: Base address + 6h (when BR = 1)

Bit	R/W	Default	Description
7-0	R/W	00h	Baud Rate Divisor High Byte (BDHR[7:0]) These bits are the high byte of the register used to divide the Baud Rate clock.

Baud rate divisor = 115200 / baud rate

Ex1: 2400 bps → 115200 / 2400 = 48 → 48(d) = 0030(h) → BDHR = 00h, BDLR = 30h

Ex2: bit width = 0.565 ms → 1770 bps → 115200 / 1770 = 65(d) = 0041(h) → BDHR = 00(h), BDLR = 41(h)

9.11.6.8 CIR Transmitter Status Register (TSR)

The TSR, an 8-bit **read only** register, provides the Transmitter FIFO status.

Address: Base address + 5h

Bit	R/W	Default	Description
7 – 6	R	-	Reserved
5 – 0	R	000000b	Transmitter FIFO Byte Count (TXFBC[5:0]) Return the number of bytes left in the Transmitter FIFO.

9.11.6.9 CIR Receiver FIFO Status Register (RSR)

The RSR, an 8-bit **read only** register, provides the Receiver FIFO status.

Address: Base address + 6h

Bit	R/W	Default	Description
7	R	0b	Receiver FIFO Time-out (RXFTO) This bit will be set to “1” when a Receiver FIFO time-out condition occurs. The conditions that must exist for a Receiver FIFO time-out condition to occur include the followings: a. At least one byte has been in the Receiver FIFO is not empty for 64 ms more b. The receiver has been inactive (RXACT=0) for over 64 ms or more c. More than 64 ms have elapsed since the last byte was read from the Receiver FIFO by the CPU
6	-	-	Reserved
5 – 0	R	000000b	Receiver FIFO Byte Count (RXFBC) Return the number of bytes left in the Receiver FIFO.

9.11.6.10 CIR Interrupt Identification Register (IIR)

The IIR, an 8-bit register, is used to identify the pending interrupts.

Address: Base address + 7h

Bit	R/W	Default	Description
7 - 3	-	-	Reserved
2 – 1	R	00b	Interrupt Identification These two bits are used to identify the source of the pending interrupt. IIR[1:0] Interrupt Source 00 No interrupt 01 Transmitter Low Data Level Interrupt 10 Receiver Data Stored Interrupt 11 Receiver FIFO Overrun Interrupt
0	R	1b	Interrupt Pending This bit will be set to “1” while an interrupt is pending.

9.12 Game Port Interface

The Game Port integrates four timers for two joysticks. The IT8722F allows the Game Port base address to be located anywhere within the host I/O address space from 100h to 0FFFh. Currently, most game software assume that the Game (or Joystick) I/O port is located at 201h.

A write to the Game port base address will trigger four timers. A read from the same address returns four bits corresponding to the outputs from the four timers and four status bits corresponding to the joystick buttons. A button value of 0 indicates that the button is pressed. When the Game port base address is written, the X/Y timer bits go high. Once the Game port base address is written, each timer output remains high for a period of time specified by the current joystick position.

9.12.1 Game Port (Base+0h)

Bit	Symbol	Description
7	JSBB2	Joystick B, Button 2 (pin 20 of Joystick connector)
6	JSBB1	Joystick B, Button 1 (pin 21 of Joystick connector)
5	JSAB2	Joystick A, Button 2 (pin 24 of Joystick connector)
4	JSAB1	Joystick A, Button 1 (pin 25 of Joystick connector)
3	JSBCY	Joystick B, Coordinate Y (pin 22 of Joystick connector)
2	JSBCX	Joystick B, Coordinate X (pin 23 of Joystick connector)
1	JSACY	Joystick A, Coordinate Y (pin 26 of Joystick connector)
0	JSACX	Joystick A, Coordinate X (pin 27 of Joystick connector)

9.13 MIDI Interface

The IT8722F supports the MIDI capability by incorporating hardware to emulate the MPU-401 in the UART mode. It is software compatible with MPU-401 interface, but only supports the UART mode (non-intelligent mode). The UART is used to convert parallel data to the serial data required by MIDI. The serial data format is RS-232 like: 1 start bit, 8 data bits and 1 stop bit. The serial data rate is fixed at 31.25K baud.

9.13.1 MPU-401 Register Interface

The MPU-401 logical device occupies two consecutive I/O spaces. The device also uses an interrupt. Both the base address and the interrupt level are programmable. MIDI Base+0 is the MIDI Data port and MIDI Base+ 1 is the Command/Status port.

MIDI Data Port:

The MIDI Data Port is used to transmit and receive MIDI data. When in the UART mode, all transmit data are transferred through a 16-byte FIFO and receive data through another 16-byte FIFO.

MIDI Data Port, MIDI base+0, Read/Write

Bit	Symbol	Description
7-0	D7-D0	MIDI data 7-0.

Command/Status Port:

The Command register is used to send instructions to the MPU-401. The Status register is used to receive status information from the MPU-401. These two registers occupy the same I/O address.

Command Port, MIDI base+1, Write Only

Bit	Symbol	Description
7-0	C7-C0	MIDI instruction command code 7-0.

Status Port, MIDI base+1, Read Only

Bit	Symbol	Description
7	RXS	Receive Buffer Status Flag 0: Data in Receive Buffer. 1: Receive Buffer empty.
6	TXS	Transmit Buffer Status Flag 0: Transmit Buffer not full. 1: Transmit Buffer full.
5-0	-	Reserved, always report 3Fh.

9.13.2 Operation

In the IT8722F, only two MPU-401 device instructions are available: RESET (code: FFh) and UART mode command (code: 3Fh). After power-up reset, the interface is in the **Intelligent mode** (non-UART mode). In this mode, the operation is defined as follows:

1. All reads of the DATA port, MIDI base+0, return the acknowledged code (FEh). Because only two commands are available, the receive buffer is always placed an acknowledged code in the intelligent mode.
2. All writes to the DATA port, MIDI base+0, are ignored.
3. All writes to the Command port, MIDI base+1, are monitored and acknowledged as follows:
3Fh: Sets the interface into the UART mode and loads an acknowledged code (FEh) into the receive buffer which generates an interrupt.
FFh: Sets the interface into the initialization condition.
Others: Not implemented.

UART Mode:

1. All reads of the DATA port, MIDI base+0, return the next byte in the receive buffer FIFO. The serial data received from the MIDI_IN pin is stored in the receive buffer FIFO. Bit 7 RXS of the Status register is updated to reflect the new receive buffer FIFO state. The receive data available interrupt will be issued only if the FIFO has reached its programmed trigger level. They will be cleared as soon as the FIFO drops below its trigger level. The trigger level is programmable by changing bits 2-1 of the MIDI port Special Configuration register, LDN8_F0h.
2. All writes to the DATA port, MIDI base+0, are placed in the transmit buffer FIFO. Whenever the transmit buffer FIFO is not empty, the data bytes are read from the buffer in turn and sent out from the MIDI_OUT pin. Bit 6 TXS of the Status register is updated to reflect the new transmit buffer FIFO state.
3. All writes to the Command port, MIDI base+1, are monitored and acknowledged as follows:
FFh: Sets the interface into the initial condition. The interface returns to the intelligent mode.
Others: No operation.

9.14 Memory Stick Host Controller

9.14.1 Overview

The Memory Stick Host Controller provides the interface between a host processor and Memory Stick I/F. The Memory Stick Interface complies with Sony Memory Stick Standard Ver 1.3. It supports up to 20MHz clock.

9.14.2 Features

- Memory Stick V1.3 Specifications compliant
- Up to 20MHz interface serial clock
- Built-in 16-byte FIFO buffers for transmit and receive respectively
- Built-in CRC circuit
- DMA supported
- Interrupt polling transmission supported
- Automatic command execution (can be turned on/off) when INT from the Memory Stick is detected

9.14.3 Register Descriptions

Table 9-52. Memory Stick Register List

Address	R/W	Default	Name
Base + 0h	R/W	01h	MS Command 1 Register
Base + 1h	R/W	00h	MS Command 2 Register
Base + 2h	R	0Ah	MS Status Register
Base + 3h	R/W	05h	MS Control Register
Base + 4h	R	00h	MS Receive Data Buffer Register
Base + 4h	W	00h	MS Transmit Data Buffer Register
Base + 5h	R/W	70h	MS ACD Command Register
Base + 6h	R/W	00h	MS Interrupt Control Register
Base + 7h	R	80h	MS Interrupt Data Register

9.14.3.1 MS Command 1 Register

The MS Command 1, an 8-bit **read/write** register, is the data size [7:0] for Command.

Address: Base address + 0h

Bit	R/W	Default	Description
7 – 0	R/W	01h	Data Size [7:0] Register This register is Data size [7:0] (total 10 bits), value determined for each PID code.

9.14.3.2 MS Command 2 Register

The MS Command 2, an 8-bit **read/write** register, determines PID code (4 bits) and the data size [9:8] for Command.

Address: Base address + 1h

Bit	R/W	Default	Description
7 – 4	R/W	0h	Packet ID (PID) Register PID code (4 bits).
3 – 2	-	-	Reserved for ITE use.
1 – 0	R/W	0h	Data Size [9:8] Register This register is Data size [9:8] (total 10 bits), value determined for each PID code.

9.14.3.3 MS Status Register

The MS Status, an 8-bit **read Only** register, is used to respond the status of the MS controller.

Address: Base address + 2h

Bit	R/W	Default	Description
7	R	0b	Interrupt (INT) This bit is "1" when an interrupt condition is generated, Otherwise, "0". Change even when the INTEN bit of the Interrupt Control Register is "0".
6	R	0b	Data Request (DARQ) This bit is "1" when data transfer is requested. Otherwise, "0".
5 – 4	-	-	Reserved for ITE use.
3	R	1b	Receive Buffer Empty (RBE) This bit is "1" when receive data buffer is empty. It is "0" when there are data in receive data buffer.
2	R	0b	Receive Buffer Full (RBF) This bit is "1" when receive data buffer is full. It is "0" when there is space in receive data buffer.
1	R	1b	Transmit Buffer Empty (TBE) This bit is "1" when transmit data buffer is empty. It is "0" when there is data in transmit data buffer.
0	R	0b	Transmit Buffer Full (TBF) This bit is "1" when transmit data buffer is full. It is "0" when there is space in transmit data buffer.

9.14.3.4 MS Control Register

The MS Control, an 8-bit **read/write** register, is used to determine some parameters for the MS controller.

Address: Base address + 3h

Bit	R/W	Default	Description
7	R/W	0b	Reset (RST) Internal reset when "1", canceled when "0".
6	R/W	0b	Power Save (PWS) Power save mode when "1", canceled when "0". During PWS=1, the clock of Memory Stick I/F side logic is stopped. MS Command 1, 2, MS ACD registers are not performed to write.
5	R/W	0b	Serial I/F Enable (SIEN) Serial IF output enabled when "1", disabled when "0". Normally set to "1" during operation.
4	R/W	0b	DMA Enable (DMAEN) DMA enabled when "1", disabled when "0".
3	R/W	0b	No CRC (NOCRC) CRC is off when "1" and on when "0". In mode, data is transmitted/received without adding a CRC (16-bit) at the end of the data array.
2 – 0	R/W	5h	Busy Count (BSYCNT) RDY timeout time setting (serial clock count). These bits are set to the maximum BSY timeout time (set value X 4 + 2) to wait until the RDY signal is output from the card. RDY timeout error detection is not performed when BSYCNT = 0.

9.14.3.5 MS Receive Data Buffer Register

The MS Receive Data Buffer with 16 bytes FIFO holds receive incoming data byte.

Address: Base address + 4h

Bit	R/W	Default	Description
7 – 0	R	00h	Receive Data Buffer Register When RBE is “1”, invalid data are read.

9.14.3.6 MS Transmit Data Buffer Register

The MS Transmit Data Buffer with 16 bytes FIFO contains the data byte that is to be transmitted.

Address: Base address + 4h

Bit	R/W	Default	Description
7 – 0	W	00h	Receive Data Buffer Register When TBF is “1”, writing data are ignored.

9.14.3.7 MS ACMD Register

The MS ACMD, an 8-bit **read/write** register, determines APID code (4 bits) and the ADATASIZE for Auto Command.

Address: Base address + 5h

Bit	R/W	Default	Description
7 – 4	R/W	7h	Auto Command Packet ID (APID) Register APID code (4 bits).
3	-	-	Reserved for ITE use.
2 – 0	R/W	0h	Auto Command Data Size [2:0] Register This register is Data size [2:0], value determined for each APID code.

9.14.3.8 MS Interrupt Control Register

The MS Interrupt Control, an 8-bit **read/write** register, is used to enable some interrupt events for the MS controller.

Address: Base address + 6h

Bit	R/W	Default	Description
7	R/W	0b	Interrupt Enable (INTEN) Interrupt is enabled when “1”, and disabled when “0”. An interrupt is generated when an interrupt condition occurs after INTEN has been set to “1”.
6	R/W	0b	Data Request Interrupt Enable (DRQSL) Interrupt during data transfer request is enabled when “1”, and disabled when “0”. An interrupt is generated when an interrupt condition occurs after INTEN has been set to “1”.
5	R/W	0b	Card Detect Interrupt Enable (CDIEN) Interrupt for MSDET (MSDET_S) level changing is enabled when “1”, and disabled when “0”.
4	R/W	0b	Power On (PWRON) MSPWR (MSPWR_S) is low when “1”, and High-Z when “0”.
3 – 2	-	-	Reserved for ITE use.
1	R/W	0h	Auto Command (ACD) When this bit is set to “1”, an ACD command is automatically executed after an INT is detected. When “0”, disable the ACD command.
0	R/W	0h	Rise Edge Data (RED) When this bit is set to “1”, serial data are loaded at the falling edge of the clock. When “0”, loaded at the rising edge.

9.14.3.9 MS Interrupt Data Register

The MS Status, an 8-bit **read Only** register, is used to respond the Interrupt event data of the MS controller.

Address: Base address + 7h

Bit	R/W	Default	Description
7	R	1b	Ready (RDY) This bit is "1" when the Protocol is ended. "0" when communications with Memory Stick.
6	R	0b	Serial I/F Interrupt (SIF) This bit is "1" when the Serial I/F receives INT, otherwise "0". An interrupt output for SIF is separated from one for RDY.
5	R	0b	Data Request (DARQ) This bit is "1" when data transfer is requested, otherwise "0". DARQ can be changed only when the DRQSL of Interrupt Control register is "1".
4	R	0b	Card Detect Interrupt (CDI) This bit is "1" when MSDET (MSDET_S) level changing is occurred, otherwise "0". Reading this register will clear this bit.
3 – 2	-	-	Reserved for ITE use.
1	R	0b	CRC Error (CRC) This bit is "1" when a CRC error occurs while receiving data, and "0" when normal. It is cleared to "0" when data are written to the MS Command Register. BS output is set to Low level when a CRC error occurs.
0	R	0b	Timeout Error (TOE) This bit is "1" when BSY timeout error occurs, and "0" during normal operations. It is cleared to "0" when data are written to the MS Command Register. Exceeding the number of clocks set using BSYCNT of the MS Control Register and BSY from the Memory Stick continues, it is taken as a card malfunction and an RDY timeout error (TOE) is set out.

9.15 SD Host Controller

9.15.1 Overview

The SD (Secure Digital) Host Controller provides the interface between a host processor (LPC interface) and SD I/F. On SD I/F side, it offers four serial data lines, a serial command line and synchronous clock. Both SD memory card and I/O card Interfaces are supported.

9.15.2 Features

- Built-in CRC circuit: CRC7 for commands and CRC16 for Data
- SD Memory/IO Card/MMC Interface supported: COMMAND (1line) and Data/INT/Card Detect (4 lines)
- 512-byte FIFO buffers
- DMA supported
- Interrupt polling transmission supported
- The transfer data length can be either set up to 2⁹ bytes or 1 byte.
- Sector counter for multiple Read/Write operation

9.15.3 Register Descriptions

Table 9-53. SD Host Controller Access Port

Address	R/W	Default	Name
Base + 0h	R/W	00h	SD Host Controller Access Index Port
Base + 1h	R/W	--	SD Host Controller Access Data Port

Table 9-54. SD Host Controller Register

Index	R/W	Default	Name
00h	R/W	00h	SD_CMD
01h	R/W	00h	SD_CMD_MD
02h	R/W	00h	SD_PORTSEL
04h	R/W	00h	SD_ARG1
05h	R/W	00h	SD_ARG2
06h	R/W	00h	SD_ARG3
07h	R/W	00h	SD_ARG4
08h	R/W	00h	SD_STOP
09h	R/W	00h	SD_SEC_EN
0Ah	R/W	00h	SD_SECCNTL
0Bh	R/W	00h	SD_SECCNTH
0Ch	R	--	SD_RSP0
0Dh	R	--	SD_RSP1
0Eh	R	--	SD_RSP2
0Fh	R	--	SD_RSP3
10h	R	--	SD_RSP4
11h	R	--	SD_RSP5
12h	R	--	SD_RSP6
13h	R	--	SD_RSP7
14h	R	--	SD_RSP8
15h	R	--	SD_RSP9
16h	R	--	SD_RSP10
17h	R	--	SD_RSP11
18h	R	--	SD_RSP12
19h	R	--	SD_RSP13
1Ah	R	--	SD_RSP14
1Bh	R	--	SD_RSP15
1Ch	R/W-R	00h	SD_INFOL
1Dh	R/W-R	00h	SD_INFOH

SD Host Controller Register [cont'd]

Index	R/W	Default	Name
1Eh	R/W-R	00h	SD_BUFSTS
1Fh	R/W-R	00h	SD_ERR
20h	R/W	1Dh	SD_INFOL_MASK
21h	R/W	03h	SD_INFOH_MASK
22h	R/W	7Fh	SD_BUFSTS_MASK
23h	R/W	83h	SD_ERR_MASK
24h	R/W	20h	SD_CLK_CTRL
25h	R/W	00h	SD_CLK_CTRLH
26h	R/W	00h	SD_SIZE
27h	R/W	02h	SD_SIZEH
28h	R/W	EEh	SD_OPTION1
29h	R/W	00h	SD_OPTION2
2Ch	R/W	00h	SD_CMD_END_ERR_STS
2Dh	R/W	20h	SD_CRC_ERR_STS
2Eh	R/W	00h	SD_TIMEOUT_ERR_STS
30h	R/W	00h	SD_BUFL
31h	R/W	00h	SD_BUFH
34h	R/W	00h	SDIO_MODE
36h	R/W	00h	SDIO_INFOL
37h	R/W	00h	SDIO_INFOH
38h	R/W	01h	SDIO_INFOL_MASK
39h	R/W	00h	SDIO_INFOH_MASK
6Ch	R/W	00h	DMA_EN
E0h	R/W	00h	SOFT_RST
E2h	R/W	02h	VERSION
F2h	R/W	00h	Power Control
F4h	R/W	00h	EXT_SDIO
F5h	R/W	07h	EXT_SDIO_MASK
F6h	R	--	EXT_WP
FAh	R/W-R	--	EXT_CD_DAT3
FEh	R/W	FFh	EXT_CD_DAT3_MASK

9.15.3.1 SD Command Register (SD_CMD)

The SD Command, an 8-bit **read/write** register, is the data size [7:0] for Command parameter.
For example:

CMD6 is corresponding to 8'b00_000110.
CMD18 is corresponding to 8'b00_010010.
ACMD13 is corresponding to 8'b01_001101.

Index: 00h

Bit	R/W	Default	Description
7 – 6	R/W	00b	Command Type (CT[1:0]) 00b : CMD of SD Memory Card / MultiMediaCard 01b : ACMD followed by CMD55 of SD Memory Card 10b : Command for Mutual Authentication 11b : Reserved
5 – 0	R/W	00h	Command Format (CF[45:40]) Correspond to bit position of Command Format [45:40] (command index).

9.15.3.2 SD Command Mode Register (SD_CMD_MD)

The SD Command Mode, an 8-bit **read/write** register, is the data size [7:0] for Command Mode selection.

Index: 01h

Bit	R/W	Default	Description
7 – 6	R/W	00b	Command mode 00b : Normal command (CMD12 is auto transfer) 01b : SDIO command (Host < - > Card) (CMD12 not auto transfer) 10b : Reserved 11b : Reserved SDIO command is only used by extended commands. CMD12 auto transfer means that it will stop transmission by sector count.
5	R/W	0b	Multiple block transfer enable This bit is used to select single/Multiple block transfer (effective only in case of with data). 0 Single Block Transfer. 1 Multiple Block Transfer.
4	R/W	0b	Write/Read mode This bit is used to select Write/Read transfer (effective only in case of with data). 0 Write (Host → SD Card). 1 Read (Host ← SD Card).
3	R/W	1b	Data mode enable 0 Without Data. 1 With Data.

Index: 01h [cont'd]

Bit	R/W	Default	Description																											
2 – 0	R/W	0b	Extend command mode and Response type select <table border="1"> <thead> <tr> <th>Code</th> <th>Command mode</th> <th>Response</th> </tr> </thead> <tbody> <tr> <td>000b</td> <td>Normal mode</td> <td>Decoded command</td> </tr> <tr> <td>001b</td> <td>Extended command</td> <td>Reserved</td> </tr> <tr> <td>010b</td> <td>Extended command</td> <td>Reserved</td> </tr> <tr> <td>011b</td> <td>Extended command</td> <td>No response</td> </tr> <tr> <td>100b</td> <td>Extended command</td> <td>R1, R6, R5</td> </tr> <tr> <td>101b</td> <td>Extended command</td> <td>R1b</td> </tr> <tr> <td>110b</td> <td>Extended command</td> <td>R2</td> </tr> <tr> <td>111b</td> <td>Extended command</td> <td>R3, R4</td> </tr> </tbody> </table> <p>Controller will not reflect the value of bits 7-3 on mode (000b). If software selects normal mode (000b), controller automatically decides response type and transfer mode (data mode, write/read mode, and single/multiple block) for command index. If software selects extended mode (011b to 111b), software must set appropriate value in bits 7-3 for command index. Controller decides CMD7 and CMD12 with R1b response in normal mode (000b). If you want to use No response for CMD7 or CMD12, you need to set extend command.</p>	Code	Command mode	Response	000b	Normal mode	Decoded command	001b	Extended command	Reserved	010b	Extended command	Reserved	011b	Extended command	No response	100b	Extended command	R1, R6, R5	101b	Extended command	R1b	110b	Extended command	R2	111b	Extended command	R3, R4
Code	Command mode	Response																												
000b	Normal mode	Decoded command																												
001b	Extended command	Reserved																												
010b	Extended command	Reserved																												
011b	Extended command	No response																												
100b	Extended command	R1, R6, R5																												
101b	Extended command	R1b																												
110b	Extended command	R2																												
111b	Extended command	R3, R4																												

9.15.3.3 SD Port Selection Register (SD_PORTSEL)

The SD Port Selection, an 8-bit **read/write** register, selects one of the appropriate SD Memory Cards.

Index: 02h

Bit	R/W	Default	Description
7 – 2	-	-	Reserved for ITE use.
1 – 0	R/W	00b	Port Select 00 : Select Port 0 01 : Select Port 1 10 : Reserved 11 : Reserved

9.15.3.4 SD Command Argument Register (SD_ARG4, SD_ARG3, SD_ARG2, and SD_ARG1)

The SD Command Argument, four **read/write** registers, are corresponded to bit position of Command Format [39:8] (argument).

Index: 04h (SD_ARG1)

Bit	R/W	Default	Description
7 – 0	R/W	00b	Command Format [15:8] (CF[15:8])

Index: 05h (SD_ARG2)

Bit	R/W	Default	Description
7 – 0	R/W	00b	Command Format [23:16] (CF[23:16])

Index: 06h (SD_AR3)

Bit	R/W	Default	Description
7 – 0	R/W	00b	Command Format [31:24] (CF[31:24])

Index: 07h (SD_ARG4)

Bit	R/W	Default	Description
7 – 0	R/W	00b	Command Format [39:32] (CF[39:32])

9.15.3.5 Data Stop Register (SD_STOP)

The Data Stop, an 8-bit **read/write** register, is used to stop the transfer.

Index: 08h

Bit	R/W	Default	Description
7 – 1	R/W	00h	Reserved for ITE use.
0	R/W	0h	STOP Set 1 to this bit to transfer CMD12 and the transmission state of the controller will be aborted. Set 0 to this bit just before CMD17, CMD18, CMD24, CMD25, CMD27, CMD30, CMD42, CMD56, ACMD43-48, ACMD18, or ACMD25 are set.

9.15.3.6 Transfer Sector Counter Enable Register (SD_SEC_EN)

The Transfer Sector Counter Enable, an 8-bit **read/write** register, is used to enable Transfer Sector Counter.

Index: 09h

Bit	R/W	Default	Description
7 – 1	R/W	00h	Reserved for ITE use.
0	R/W	0h	SECEN Set 1 to this bit to Transfer Sector Counter. Set 0 to this bit to disable. It is recommended to use the sector counter function in CMD18 and CMD25. This function will transmit CMD12 automatically.

9.15.3.7 Transfer Sector Count Register (SD_SECCNTL and SD_SECCNTH)

The Transfer Sector Count, a 16-bit **read/write** register (two bytes), is used to determine transfer sector count. This register is enabled when SECEN of SD_SEC_EN register is set to “1”. The size of transfer unit has to be 512 bytes (one sector). If set 0001h to CNT [15:0], the transfer sector count is 1. If FFFFh is set to CNT [15:0], the transfer sector count is 65535. If 0000h is set to CNT [15:0] and CNT [15:0], the transfer sector count is 65536. Hardware performs decrement of this counter internally for transfer multiple sector data. Finally, when all data are sent out or received, hardware will send STOP_TRANSMISSION to SD Memory Card automatically.

Index: 0Ah (SD_SECCNTL)

Bit	R/W	Default	Description
7-0	R/W	00b	Count [7:0] (CNT[7:0])

Index: 0Bh (SD_SECCNTH)

Bit	R/W	Default	Description
7-0	R/W	00b	Count [15:8] (CNT[15:8])

9.15.3.8 SD Memory Card Response Register (SD_RSP0 – SD_RSP14)

The SD Memory Card Response, 15 **read only** registers, indicate SD Memory Card response value. R2 only indicates bit position 127:8 because CRC is calculated by hardware.

Response meaning and registers:

Response type	Meaning of Response	Registers
R1, R1b (normal response)	Card Status	RSP [39:8]
R2 (CID, CSD registers)	CID or CSD registers	RSP [127:8]
R3 (OCR register)	OCR register	RSP [39:8]
[R4 (Fast I/O)	RCA, reg addr, read reg content	RSP [39:8]]
[R5 (Interrupt)	RCA [31:16], [15:0] are not defined	RSP [39:8]]
R6 (Published RCA response)	New published RCA [31:16] etc.	RSP [39:8]

Index: 0Ch (SD_RSP0)

Bit	R/W	Default	Description
7-0	R	--	Response [15:8] (RSP[15:8])

Index: 0Dh (SD_RSP1)

Bit	R/W	Default	Description
7-0	R	--	Response [23:16] (RSP[23:16])

Index: 0Eh (SD_RSP2)

Bit	R/W	Default	Description
7-0	R	--	Response [31:24] (RSP[31:24])

Index: 0Fh (SD_RSP3)

Bit	R/W	Default	Description
7-0	R	--	Response [39:32] (RSP[39:32])

Index: 10h (SD_RSP4)

Bit	R/W	Default	Description
7-0	R	--	Response [47:40] (RSP[47:40])

Index: 11h (SD_RSP5)

Bit	R/W	Default	Description
7-0	R	--	Response [55:48] (RSP[55:48])

Index: 12h (SD_RSP6)

Bit	R/W	Default	Description
7-0	R	--	Response [63:56] (RSP[63:56])

Index: 13h (SD_RSP7)

Bit	R/W	Default	Description
7-0	R	--	Response [71:64] (RSP[71:64])

Index: 14h (SD_RSP8)

Bit	R/W	Default	Description
7-0	R	--	Response [79:72] (RSP[79:72])

Index: 15h (SD_RSP9)

Bit	R/W	Default	Description
7-0	R	--	Response [87:80] (RSP[87:80])

Index: 16h (SD_RSP10)

Bit	R/W	Default	Description
7-0	R	--	Response [95:88] (RSP[95:88])

Index: 17h (SD_RSP11)

Bit	R/W	Default	Description
7-0	R	--	Response [103:96] (RSP[103:96])

Index: 18h (SD_RSP12)

Bit	R/W	Default	Description
7-0	R	--	Response [111:104] (RSP[111:104])

Index: 19h (SD_RSP13)

Bit	R/W	Default	Description
7-0	R	--	Response [119:112] (RSP[119:112])

Index: 1Ah (SD_RSP14)

Bit	R/W	Default	Description
7-0	R	--	Response [127:110] (RSP[127:110])

9.15.3.9 SD Memory Card Information Register (SD_INFOL and SD_INFOH)

The SD Memory Card Information, a 16-bit **read/write or read only** register, responds some card's statuses of the PORT0.

Index: 1Ch (SD_INFOL)

Bit	R/W	Default	Description
7	R	--	Write Protect 0: Normal. 1: Write Protect for Port 0.
6 – 3	--	--	Reserved for ITE use.
2	R/W	0b	Write/Read Access all End Writing "0" to this bit will clear it. 0: No data response end occurs from the last clear. 1: Data response ends.
1	--	--	Reserved for ITE use.
0	R/W	0b	Response End Writing "0" to this bit will clear it. 0: No command response end occurs from the last clear. 1: Command response ends.

Index: 1Dh (SD_INFOH)

Bit	R/W	Default	Description
7 – 3	--	--	Reserved for ITE use.
2	R	--	SDA_D3 Card Detect When no data transfer, SDA_D3 is used as card detection. 0: SDA_D3 is low. 1: SDA_D3 is high.
1	R/W	0b	SDA_D3 Card Inserted Writing "0" to this bit will clear it. During four-bit data transfer, this status should be ignored. 0: No Card insertion detected from the last clear. 1: Card insertion detected.
0	R/W	0b	SDA_D3 Card Removed Writing "0" to this bit will clear it. During four-bit data transfer, this status should be ignored. 0: No Card removal detected from the last clear. 1: Card removal detected.

9.15.3.10 SD Memory Card Buffer Status Register (SD_BUFSTS)

The SD Memory Card Buffer Status, an 8-bit **read/write or read only** register, responds command statuses.

Index: 1Eh

Bit	R/W	Default	Description
7	R/W	0b	Illegal Access Error (ILA) Writing "0" to this bit will clear it. 0: Normal from the last clear. 1: Illegal accessing error. There are 3 cases. Case 1: Even if transaction is active, host writes SD_CMD register. Case 2: Software sets SD_CMD_MD[2:0]=3'b011 (no response) and SD_CMD_MD[3]=1'b1 (with data). Case 3: Software sets SD_CMD_MD[3]=1'b1 (with data) when SD_CMD=8'b00001100 (CMD12) is set.
6	R	0b	Command Busy (CBSY) 0: Command transaction finished 1: During command transaction.
5 – 2	--	0h	Reserved for ITE use
1	R/W	0b	Write Enable (BWE) Writing "0" to this bit will clear it. 0: Normal from the last clear. 1: Writing buffer to SD Memory Card is empty. (The size is specified by SD_SIZE.)
0	R/W	0b	Read Enable (BRE) Writing "0" to this bit will clear it. 0: Normal from the last clear. 1: Write buffer to SD Memory Card is empty. (The size is specified by SD_SIZE.)

9.15.3.11 SD Memory Card Error Register (SD_ERR)

The SD Memory Card Error, an 8-bit **read/write or read only** registers, respond error messages. About Erase command, if Timeout error (ERR3) occurs but there is no Response timeout error (ERR6), software can know the end of Erase Command by polling the DAT0 (SDA_D0 or SDB_D0) as high.

Index: 1Fh

Bit	R/W	Default	Description
7	R	--	DAT0 (SDA_D0 or SDB_D0) of the selected port This bit responds DAT0 of the selected port (by SD_PORTSEL). 0: DAT0 of the selected port is "0". 1: DAT0 of the selected port is "1".
6	R/W	0b	Response Timeout (ERR6) Writing "0" to this bit will clear it. 0: Normal from the last clear. 1: Response timeout occurs. There are two cases: Case 1: No command responds more than 640 SDCLK cycles. Case 2: No SD_STOP responds more than 640 SDCLK cycles.

Index: 1Fh [cont'd]

Bit	R/W	Default	Description
5	R/W	0b	Illegal Read Access (ERR5) Writing "0" to this bit will clear it. 0: Normal from the last clear. 1: Even if buffer is empty, the host still reads from it.
4	R/W	0b	Illegal Write Access (ERR4) Writing "0" to this bit will clear it. 0: Normal from the last clear. 1: If data read/write command state is not asserted, the host still writes to buffer.
3	R/W	0b	Timeout (except response time out) (ERR3) Writing "0" to this bit will clear it. 0: Normal from the last clear. 1: Timeout occurs (except response timeout). There are five cases: Case 1: Keep busy (DAT0=0) more than N cycles after R1b response. Case 2: Keep busy (DAT0=0) more than N cycles after Write CRC Status. Case 3: No write CRC Status more than N cycles after Write cycle. Case 4: No Read Data more than N cycles after Read Command. Case 5: Keep busy more than N cycles after SD_STOP. N is determined by SD_OPTION register bits 7-4.
2	R/W	0b	End Error (ERR2) Writing "0" to this bit will clear it. 0: Normal from the last clear. 1: End error occurs. There are four cases: Case1: END bit error in Command response (Illegal response length). Case2: END bit error in Read Data (Illegal data length). Case3: END bit error in Write CRC Status (Illegal CRC status length). Case4: END bit error in SD_STOP response.
1	R/W	0b	CRC Error (ERR1) Writing "0" to this bit will clear it. 0: Normal from the last clear. 1: CRC error occurs. There are four cases: Case1: Error in Write CRC Status. Case2: CRC error in Read Data. Case3: CRC error in SD_STOP response. Case4: CRC error in Command response.
0	R/W	0b	Command Error (ERR0) Writing "0" to this bit will clear it. 0: Normal from the last clear. 1: Command error occurs. There are two cases: Case1: Command index error in Command response. Case2: Command index error in SD_STOP response.

9.15.3.12 SD Memory Card Information Mask Register (SD_INFOL_MASK and SD_INFOH_MASK)

The SD Memory Card Information Mask, a 16-bit **read/write** register, enables SD_INFOL and SD_INFOH to generate interrupt with writing “0” to each bit.

Index: 20h (SD_INFOL_MASK)

Bit	R/W	Default	Description
7 – 3	--	--	Reserved for ITE use.
2	R/W	1b	Write/Read Access all End Mask 0 Enables SD_INFOL2 (Write/Read Access all End) to generate interrupt. 1 Masks SD_INFOL2 (Write/Read Access all End) to generate interrupt.
1	--	--	Reserved for ITE use.
0	R/W	1b	Response End Mask 0 Enables SD_INFOL0 (Response End) to generate interrupt. 1 Masks SD_INFOL0 (Response End) to generate interrupt.

Index: 21h (SD_INFOH_MASK)

Bit	R/W	Default	Description
7 – 2	--	--	Reserved for ITE use.
1	R/W	1b	SDA_D3 Card Inserted Mask 0 Enables SD_INFOH1 (SDA_D3 Card Inserted) to generate interrupt. 1 Masks SD_INFOH1 (SDA_D3 Card Inserted) to generate interrupt.
0	R/W	1b	SDA_D3 Card Removed Mask 0 Enables SD_INFOH0 (SDA_D3 Card Removed) to generate interrupt. 1 Masks SD_INFOH0 (SDA_D3 Card Removed) to generate interrupt.

9.15.3.13 SD Memory Card Buffer Status Mask Register (SD_BUFSTS_MASK)

The SD Memory Card Buffer Status Mask, an 8-bit **read/write or read only** register, enables SD_BUFSTS to generate interrupt with writing “0” to each bit.

Index: 22h

Bit	R/W	Default	Description
7	R/W	1b	Illegal Access Error Mask (IMASK) 0 Enables SD_BUFSTS7 (Illegal Access Error) to generate interrupt. 1 Masks SD_BUFSTS7 (Illegal Access Error) to generate interrupt.
6 – 2	--	00h	Reserved for ITE use.
1	R/W	1b	Write Enable Mask (BMSK1) 0 Enables SD_BUFSTS1 (Write Enable) to generate interrupt. 1 Masks SD_BUFSTS1 (Write Enable) to generate interrupt.
0	R/W	1b	Read Enable Mask (BMSK0) 0 Enables SD_BUFSTS0 (Read Enable) to generate interrupt. 1 Masks SD_BUFSTS0 (Read Enable) to generate interrupt.

9.15.3.14 SD Memory Card Error Mask Register (SD_ERR_MASK)

The SD Memory Card Error Mask, an 8-bit **read/write or read only** register, enables SD_ERR to generate interrupt with writing "0" to each bit.

Index: 23h

Bit	R/W	Default	Description
7	--	0b	Reserved for ITE use.
6	R/W	1b	Response Timeout Mask (EMASK6) 0 Enables ERR6 (Response Timeout) to generate interrupt. 1 Masks ERR6 (Response Timeout) to generate interrupt.
5	R/W	1b	Illegal Read Access Mask (EMASK5) 0 Enables ERR5 (Illegal Read Access) to generate interrupt. 1 Masks ERR5 (Illegal Read Access) to generate interrupt.
4	R/W	1b	Illegal Write Access Mask (EMASK4) 0 Enables ERR4 (Illegal Write Access) to generate interrupt. 1 Masks ERR4 (Illegal Write Access) to generate interrupt.
3	R/W	1b	Timeout Mask (EMASK3) 0 Enables ERR3 (Timeout) to generate interrupt. 1 Masks ERR3 (Timeout) to generate interrupt.
2	R/W	1b	End Error Mask (EMASK2) 0 Enables ERR2 (End Error) to generate interrupt. 1 Masks ERR2 (End Error) to generate interrupt.
1	R/W	1b	CRC Error Mask (EMASK1) 0 Enables ERR1 (CRC Error) to generate interrupt. 1 Masks ERR1 (CRC Error) to generate interrupt.
0	R/W	1b	Command Error Mask (EMASK0) 0 Enables ERR0 (Command Error) to generate interrupt. 1 Masks ERR0 (Command Error) to generate interrupt.

9.15.3.15 SD Clock Enable Register (SD_CLKEN)

The SD Clock Enable, a **read/write** register, enables the SDCLK divisor.

Index: 24h

Bit	R/W	Default	Description
7 – 1	--	00h	Reserved for ITE use.
0	R/W	0b	SD Clock Enable (SDCLK_EN) Software has to wait at least 250ms (SD Memory power up time) after card is inserted. 0 Disable. 1 Enable.

9.15.3.16 SD Clock Divisor Register (SD_CLK_DIV)

The SD Clock Enable, a **read/write** register, enables the SDCLK divisor.

Index: 25h

Bit	R/W	Default	Description
7 – 0	R/W	20h	SD Clock Divisor Select (SD_CLK_DIV) The frequency of SDCLK is the frequency of the clock source of SD I/F Controller (48MHz or 33MHz, selected by bit 1 of Clock Selection register. Please refer to 8.3.6) divided by Divisor. 00h: Divisor = 2. 01h: Divisor = 4. 02h: Divisor = 8. 04h: Divisor = 16. 08h: Divisor = 32. 10h: Divisor = 64. 20h: Divisor = 128. 40h: Divisor = 256. 80h: Divisor = 512. Else: Reserved.

9.15.3.17 SD Transfer Data Length Register (SD_SIZEL and SD_SIZEH)

The SD Transfer Data Length, a 10-bit **read/write** register, determines the transfer data length. For SD memory multiple Read, software can only set 512 Bytes. If undefined code is selected, the transfer data length will be 512 Bytes.

Index: 26h (SD_SIZEL)

Bit	R/W	Default	Description
7 – 3	R/W	00h	Transfer Data Length [7:0] (LEN [7:0])

Index: 27h (SD_SIZEH)

Bit	R/W	Default	Description
7 – 2	--	--	Reserved for ITE use.
1 – 0	R/W	2h	Transfer Data Length [9:8] (LEN [9:8])

Table 9-55. SD Data Transfer Data Length

LEN [9:0]	Transfer Data Length	Explanation
10'b10_0000_0000	512 Bytes (Default)	Data
10'b01_1111_1111 ~ 10'b01_0000_0001	511 Bytes ~ 257 Bytes	Only use data area access
10'b01_0000_0000	256 Bytes	
10'b00_1111_1111 ~ 10'b00_1000_0001	255 Bytes ~ 129 Bytes	Only use data area access
10'b00_1000_0000	128 Bytes	
10'b00_0111_1111 ~ 10'b00_0100_0001	127 Bytes ~4 65 Bytes	Only use data area access
10'b00_0100_0000	64 Bytes	
10'b00_0011_1111 ~ 10'b00_0010_0001	63 Bytes ~ 33 Bytes	Only use data area access
10'b00_0010_0000	32 Bytes	
10'b00_0001_1111 ~ 10'b00_0001_0001	31 Bytes ~ 17 Bytes	Only use data area access
10'b00_0001_0000	16 Bytes	
10'b00_0000_1111 ~ 10'b00_0000_1001	15 Bytes ~ 9 Bytes	Only use data area access
10'b00_0000_1000	8 Bytes	Random number etc.
10'b00_0000_0111 ~ 10'b00_0000_0101	7 Bytes ~ 5 Bytes	Only use data area access
10'b00_0000_0100	4 Bytes	
10'b00_0000_0011	3 Bytes	Only use data area access
10'b00_0000_0010	2 Bytes	
10'b00_0000_0001	1 Byte	For Lock/Unlock
10'b00_0000_0000	Not defined	

9.15.3.18 SD Access Control Option Register (SD_OPTION)

The SD Access Control Option, an 8-bit **read/write** register, controls some time counters.

Index: 28h

Bit	R/W	Default	Description
7 – 4	R/W	Eh	SD Response Timeout Counter 1111b : Timeout Test mode 1110b : SDCLK * 2 ²⁷ (Default) 1101b : SDCLK * 2 ²⁶ : : 0001b : SDCLK * 2 ¹⁴ 0000b : SDCLK * 2 ¹³
3 – 0	R/W	Eh	SD Card Detect Stability Time Counter 1111b : Timeout Test mode 1110b : SD I/F Controller Clock * 2 ²⁴ (Default) 1101b : SD I/F Controller Clock * 2 ²³ : : 0001b : SD I/F Controller Clock * 2 ¹¹ 0000b : SD I/F Controller Clock * 2 ¹⁰

9.15.3.19 SD Data Width Register (SD_DATA_SEL)

The SD Data Width, a **read/write** register, selects the transfer data width.

Index: 29h

Bit	R/W	Default	Description
7 – 1	--	00h	Reserved for ITE use.
0	R/W	0b	SD Data Width 0: 4 bits width. 1: 1 bit width.

9.15.3.20 SD CMD and END Error Status Register (SD_CMD_END_ERR_STS)

The SD CMD and END Error Status, an 8-bit **read only** register, responds Command and End error messages.

Index: 2Ch

Bit	R/W	Default	Description
7 – 6	--	00b	Reserved for ITE use.
5	R	0b	END Error in Write CRC Status 0: Normal. 1: END bit error in Write CRC Status.
4	R	0b	END Error in Read Data Status 0: Normal. 1: END bit error in Read Data.
3	R	0b	END Error in SD_STOP Response 0: Normal. 1: END bit error in SD_STOP response.
2	R	0b	END Error in Command Response 0: Normal. 1: END bit error in Command response.
1	R	0b	Command Index Error in SD_STOP Response 0: Normal. 1: Command index error in SD_STOP response.
0	R	0b	Command Index Error in Command Response 0: Normal. 1: Command index error in command response.

9.15.3.21 SD CRC Error Status Register (SD_CRC_ERR_STS)

The SD CRC Error Status, an 8-bit **read only** register, responds CRC error messages.

Index: 2Dh

Bit	R/W	Default	Description
7	--	0b	Reserved for ITE use.
6 – 4	R	010b	Write CRC Status
3	R	0b	Error in Write CRC Status 0: Normal. 1: Error in write CRC status.
2	R	0b	CRC Error in Read Data 0: Normal. 1: CRC Error in Read Data.
1	R	0b	CRC Error in SD_STOP Response 0: Normal. 1: CRC Error in SD_STOP response.
0	R	0b	CRC Error in Command Response 0: Normal. 1: CRC Error in command response.

9.15.3.22 SD Timeout Error Status Register (SD_TIMEOUT_ERR_STS)

The SD Timeout Error Status, an 8-bit **read only** register, responds Timeout error messages.

Index: 2Eh

Bit	R/W	Default	Description
7	--	0b	Reserved for ITE use.
6	R	0b	More BUSY after Write CRC Status 0: Normal. 1: Keep busy more than N cycles after Write CRC Status.
5	R	0b	No Write CRC Status 0: Normal. 1: No Write CRC Status more than N cycles after Write cycle.
4	R	0b	No Read Data in Read Command 0: Normal. 1: No Read Data more than N cycles after Read Command.
3	R	0b	More Busy after SD_STOP 0: Normal. 1: Keep busy more than N cycles after SD_STOP.
2	R	0b	More Busy after R1b Response 0: Normal. 1: Keep busy more than N cycles after R1b response.
1	R	0b	No SD_STOP Response 0: Normal. 1: No SD_STOP response more than 640 SDCLK.
0	R	0b	No Command Response 0: Normal. 1: No Command response more than 640 SDCLK.

9.15.3.23 SD Buffer Read/Write Port Register (SD_BUFL and SD_BUFH)

These register receives/transmits data from/to SD Card. This register connects to internal 512-byte buffer RAM.

Index: 30h (SD_BUFL)

Bit	R/W	Default	Description
7 – 0	R/W	00h	Buffer [7:0] (BUF [7:0])

Index: 31h (SD_BUFH)

Bit	R/W	Default	Description
7 – 0	R/W	00h	Buffer [15:8] (BUF [15:8])

9.15.3.24 SDIO Mode Control Register (SD_MODE1 and SD_MODE2)

The SDIO Mode Control registers select SDIO mode.

Index: 34h (SDIO_MODE1)

Bit	R/W	Default	Description
7 – 3	--	00h	Reserved for ITE use.
2	R/W	0b	Read Wait Request (RWREQ) This command is related when it is used on multiple read/write (CMD18, CMD25, CMD53 etc). RWREQ is not available in condition during Last sector transfer and during CMD12 and during IO abort no transaction. In these conditions, it will be disabled automatically. When RWREQ is set in the condition, it asserted EXWT. (Not pull down DAT2) It recommends setting C52PUB and RWREQ at the same time on read transfer. 0: Not reflect. When SDIO direct RW commands complete on read wait function, software should clear RWREQ. 1: Read Wait mode enables. This bit is only reflected in multiple read transfer operation. Case 1: When Read transfer with IOABT set; Read-wait (DAT2="0") is automatically released (DAT="1") after CMD52. Case 2: When Read transfer with C52PUB set; Read-wait (DAT2="0") is not automatically released (DAT2="1") after CMD52. Case 3: When no transaction; (It should not be used) When RWREQ is set, Read-wait (DAT2="0") is not asserted. RWREQ will not be automatically cleared.
1	--	0b	Reserved.
0	R/W	0b	SD IO mode (IOMOD) 0 Disable SD Host controller to receive IRQ from SDIO card on Port 0. 1 Enable SD Host controller to receive IRQ from SDIO card on Port 0.

Index: 35h (SDIO_MODE2)

Bit	R/W	Default	Description
7 – 2	--	00h	Reserved for ITE use.
1	R/W	0b	<p>SDIO Abort Data During the reception Not Cancelled (C52PUB)</p> <p>This command is related when it is used on multiple read/write (CMD18, CMD25, CMD53 etc). C52PUB is not available in condition during Last sector transfer and during CMD12 and during IO abort no transaction. In these conditions, it will be automatically disabled. When C52PUB is set in the condition, it asserted EXPUB52. (Not transfer CMD52) It recommends setting C52PUB and RWREQ at the same time on read transfer. The value in SD_ARG, set before this register is set, will be the argument of CMD52.</p> <p>0: Clear.</p> <p>1: CMD52 (none abort) is automatically transmitted when this bit is set. In addition, SD Controller transmission state can be waited. The argument of CMD52 will be the value in SD Command Argument register. C52PUB is auto clear after CMD52 response.</p> <p>Case 1: When Read transfer with RWREQ set; (none abort) CMD52 is automatically transmitted after C52PUB (with RWREQ set) was set and it receives proper sector data and SD controller transmission wait state. Read-wait (DAT2="0") is not automatically released (DAT2="1") after CMD52. Software should clear RWREQ after the response of CMD52 is finished.</p> <p>Case 2: When Write transfer; CMD52 is automatically transmitted after C52PUB is set and it transfers proper sector data and SD Controller transmission wait state.</p> <p>Case 3: When no transaction; (It should not be used.) When C52PUB is set, CMD52 will not be transferred. C52PUB is not auto-cleared.</p>
0	R/W	0b	<p>SDIO Abort Data During the reception Cancelled (IOABT)</p> <p>IOABT bit should only be used in IO multiple transaction. This command is related when it is used on multiple read/write (CMD53).</p> <p>0: Cleared.</p> <p>1: CMD52 (abort) is automatically transmitted when this bit is set and SD controller transmission state can be aborted. The value in SD_ARG, set before this register is set, will be the argument of CMD52. IOABT will not be auto-cleared. Software needs to clear this bit after command responds.</p> <p>Case 1: When Read transfer with RWREQ set; When IOABT is set, CMD52 is transferred soon. In addition, Read-wait (DAT2="0") is automatically released (DAT2="1") after CMD52 (abort).</p> <p>Case 2: When Read transfer without RWREQ set; When IOABT is set, CMD52 is transferred soon.</p> <p>Case 3: When Write transfer; When IOABT is set and block data transfers completely, CMD52 is transferred.</p> <p>Case 4: When no transaction; (It should not be used.) When IOABT is set, CMD52 will not be transferred.</p>

9.15.3.25 SD IO Card Information Register (SDIO_INFOL and SDIO_INFOH)

The SD IO Card Information, a 16-bit **read/write or read only** register, responds some IO card's statuses. If one bit of this register is set to "1" and the relative bit in SDIO_INFO_MASK is enabled (not masked), an interrupt will be asserted to the host.

Index: 36h (SDIO_INFOL)

Bit	R/W	Default	Description
7 – 3	--	00h	Reserved for ITE use.
2	R/W	0b	Read Wait Ready (RWRDY) Writing "0" to this bit will clear it. 0: Normal. 1: SD controller is ready to read wait mode. DAT2 is pulled down 2 clocks after the end of data block.
1	R/W	0b	SD IO Abort Ready (C52RDY) Write "0" to this bit will clear it. 0: Normal. 1: SD controller is ready to issue CMD52. (Data during the reception are not cancelled. But ... CMD52 is issued automatically.)
0	R/W	0b	SDIO Interrupt (IOIRQ) Writing "0" to this bit will clear it. SD controller can recognize SDIO card interrupt as follows (interrupt period); Case 1: Asynchronous interrupt; SD controller can recognize asynchronous interrupt when Without Data Transfer state. SDIO IRQ trigger is DAT1 pulled down in SDIO asynchronous interrupt period. Case 2: 4bit mode and with data command; SD controller can recognize synchronous interrupt in data transfer state. SDIO IRQ trigger is DAT1 pulled down in SDIO synchronous interrupt period. (Between data blocks) 0: No interrupt. 1: An interrupt occurs from SDIO card on port 0.

Index: 37h (SDIO_INFOH)

Bit	R/W	Default	Description
7	R/W	0b	Exclude Read Wait Area (EXWT) Writing "0" to this bit will clear it. 0: Normal. 1: When not read operation, software sets RWREQ. SD controller is fail in read wait mode. RWREQ is still asserted at end of any transaction. When RWREQ is set during Last section transfer, during CMD12, and during IO abort, EXWT will be set.
6	R/W	0b	Exclude PUB52 Area (EXPUB52) Writing "0" to this bit will clear it. 0: Normal. 1: When not read/write operation, software sets C52PUB. SD controller is fail to issue CMD52. C52PUB is still asserted at end of any transaction. When C52PUB is set during Last section transfer, during CMD12, and during IO abort, EXPUB52 will be set.
5 – 0	--	00h	Reserved for ITE use.

9.15.3.26 SDIO Card Information Mask Register (SDIO_INFOL_MASK and SDIO_INFOH_MASK)

The SDIO Card Information Mask, a 16-bit **read/write** register, enables SDIO_INFOL and SDIO_INFOH to generate interrupt with writing “0” to each bit.

Index: 20h (SDIO_INFOL_MASK)

Bit	R/W	Default	Description
7 – 3	--	--	Reserved for ITE use.
2	R/W	0b	RWRDY Mask (MEXWT) 0: Enables RWRDY of SDIO_INFOL to generate interrupt. 1: Masks RWRDY of SDIO_INFOL to generate interrupt.
1	R/W	0b	C52RDY Mask (MEXWT) 0: Enables C52RDY of SDIO_INFOL to generate interrupt. 1: Masks C52RDY of SDIO_INFOL to generate interrupt.
0	R/W	1b	IOIRQ Mask (IOMSK) 0: Enables IOIRQ of SDIO_INFOL to generate interrupt. 1: Masks IOIRQ of SDIO_INFOL to generate interrupt.

Index: 39h (SDIO_INFOH_MASK)

Bit	R/W	Default	Description
7	R/W	0b	EXWT Mask (MEXWT) 0: Enables EXWT of SDIO_INFOH to generate interrupt. 1: Masks EXWT of SDIO_INFOH to generate interrupt.
6	R/W	0b	EXPUB52 Mask (MEXPUB52) 0: Enables EXPUB52 of SDIO_INFOH to generate interrupt. 1: Masks EXPUB52 of SDIO_INFOH to generate interrupt.
5 – 0	--	00h	Reserved for ITE use.

9.15.3.27 DMA Enable Register (DMA_EN)

The DMA Enable, a **read/write** register, enables the DMA data transfer between the host and SD controller.

Index: 6Ch

Bit	R/W	Default	Description
7 – 2	--	00h	Reserved for ITE use.
1	R/W	0b	DMA Enable (DMAEN) 0: Disable. 1: Enable DMA mode for Data buffer read and write.
0	--	0b	Reserved for ITE use.

9.15.3.28 Software Reset Register (SOFT_RST)

The Software Reset, a **read/write** register, resets SD Memory Card interface module.

Index: 6Ch

Bit	R/W	Default	Description
7 – 1	--	00h	Reserved for ITE use.
0	R/W	0b	Software Reset (SDRST) 0: Reset SD Memory Card interface. 1: Release reset.

9.15.3.29 Controller Version Register (VERSION)

The Controller Version, a **read only** register, responds the controller development version.

Index: E2h

Bit	R/W	Default	Description
7 – 0	R	03h	Controller Version (VERSION)

9.15.3.30 SD Card I/F Power Register (Power Control)

Index: F2h

Bit	R/W	Default	Description
7 – 1	--	00h	Reserved for ITE use.
0	R/W	0b	Power Control (SDPWR) 0: Power off (SDPWR = Hi-Z). 1: Power ON (SDPWR = LOW).

9.15.3.31 SD IO Card Information for Port 1 Register (EXT_SDIO)

The SD IO Card Information for Port 1, an 8-bit **read/write or read only** register, includes IOIRQ1 and IOMOD1 for Port 1.

Index: F4h (EXT_SDIO)

Bit	R/W	Default	Description
7 – 5	--	0h	Reserved for ITE use.
4	R/W	0b	SD IO Mode for Port 1 (IOMOD1) 0: Disable SD Host controller to receive IRQ from SDIO card on Port 1. 1: Enable SD Host controller to receive IRQ from SDIO card on Port 1.
3 – 1	--	0h	Reserved for ITE use.
0	R/W	0b	SDIO Interrupt for Port 1 (IOIRQ1) Writing "0" to this bit will clear it. SD controller can recognize SDIO card interrupt as follows (interrupt period); Case 1: Asynchronous interrupt; SD controller can recognize asynchronous interrupt when Without Data Transfer state. SDIO IRQ trigger is DAT1 pulled down when SDIO asynchronous interrupt period. Case 2: 4bit mode and with data command; SD controller can recognize synchronous interrupt in data transfer state. SDIO IRQ trigger is DAT1 pulled down in SDIO synchronous interrupt period. (Between data blocks) 0: No interrupt. 1: An interrupt occurs from SDIO card on port 1.

9.15.3.32 SDIO Card Information Mask for Port 1 Register (EXT_SDIO MASK)

The SDIO Card Information Mask for Port 1, an 8-bit **read/write** register, enables IOIRQ1 to generate interrupt with writing “0” to it.

Index: F5h (EXT_SDIO MASK)

Bit	R/W	Default	Description
7 – 1	--	03h	Reserved for ITE use.
0	R/W	1b	IOIRQ1 Mask (IOMSK1) 0: Enables IOIRQ1 of EXT_SDIO to generate interrupt. 1: Masks IOIRQ1 of EXT_SDIO to generate interrupt.

9.15.3.33 Write Protect for Port 1 Register (EXT_WP)

Index: F6h (EXT_WP)

Bit	R/W	Default	Description
7 – 1	--	--	Reserved for ITE use.
0	R	--	Write Protect for Port 1 0: Normal. 1: Write Protect for Port 1.

9.15.3.34 Card Detect with SDB_DAT3 Register (EXT_CD_DAT3)

Index: 1Dh (EXT_CD_DAT3)

Bit	R/W	Default	Description
7 – 3	--	--	Reserved for ITE use.
2	R	--	SDB_D3 Card Detect When there is no data transfer, SDB_D3 is used as card detection. 0: SDB_D3 is low. 1: SDB_D3 is high.
1	R/W	0b	SDB_D3 Card Inserted Writing “0” to this bit will clear it. During four-bit data transfer, this status should be ignored. 0: No Card insertion detected from the last clear. 1: Card insertion detected.
0	R/W	0b	SDB_D3 Card Removed Writing “0” to this bit will clear it. During four-bit data transfer, this status should be ignored. 0: No Card removal detected from the last clear. 1: Card removal detected.

9.15.3.35 Card Detect with SDB_DAT3 Mask Register (EXT_CD_DAT3_MASK)

Index: FEh (EXT_CD_DAT3_MASK)

Bit	R/W	Default	Description
7 – 2	--	--	Reserved for ITE use.
1	R/W	1b	SDB_D3 Card Inserted Mask 0: Enables bit 1 of EXT_CD_DAT3 (SDB_D3 Card Inserted) to generate interrupt. 1: Masks bit 1 of EXT_CD_DAT3 (SDB_D3 Card Inserted) to generate interrupts.
0	R/W	1b	SDB_D3 Card Removed Mask 0 Enables bit 0 of EXT_CD_DAT3 (SDB_D3 Card Removed) to generate interrupt. 1 Masks bit 0 of EXT_CD_DAT3 (SDB_D3 Card Removed) to generate interrupts.

10. DC Electrical Characteristics

Absolute Maximum Ratings*

Applied Voltage.....	-0.5V to 7.0V
Input Voltage (Vi)	-0.5V to VCC+0.5V
Output Voltage (Vo)	-0.5V to VCC + 0.3V
Operation Temperature (Topt).....	0°C to +70°C
Storage Temperature.....	-55°C to +125°C
Power Dissipation	300mW

*Comments

Stresses above those listed under "Absolute Maximum Ratings" may cause permanent damage to this device. These are stress ratings only. Functional operation of this device at these or any other conditions above those indicated in the operational sections of this specification is not implied or intended. Exposure to the absolute maximum rating conditions for extended periods may affect device reliability.

DC Electrical Characteristics (VCC = 5V ± 5%, Ta = 0°C to + 70°C)

Symbol	Parameter	Min.	Typ.	Max.	Unit	Conditions
DO8 Buffer						
V _{OL}	Low Output Voltage			0.4	V	I _{OL} = 8 mA
V _{OH}	High Output Voltage	2.4			V	I _{OH} = -8 mA
DOD8 Buffer						
V _{OL}	Low Output Voltage			0.4	V	I _{OL} = 8 mA
DO16 Buffer						
V _{OL}	Low Output Voltage			0.4	V	I _{OL} = 16 mA
V _{OH}	High Output Voltage	2.4			V	I _{OH} = -16 mA
DO24 Buffer						
V _{OL}	Low Output Voltage			0.4	V	I _{OL} = 24 mA
V _{OH}	High Output Voltage	2.4			V	I _{OH} = -24 mA
DO40 Buffer						
V _{OL}	Low Output Voltage			0.5	V	I _{OL} = 48 mA
V _{OH}	High Output Voltage	2.4			V	I _{OH} = -6 mA
DIO8 Type Buffer						
V _{OL}	Low Output Voltage			0.4	V	I _{OL} = 8 mA
V _{OH}	High Output Voltage	2.4			V	I _{OH} = -8 mA
V _{IL}	Low Input Voltage			0.8	V	
V _{IH}	High Input Voltage	2.2			V	
I _{IL}	Low Input Leakage		10		μA	V _{IN} = 0
I _{IH}	High Input Leakage			-10	μA	V _{IN} = VCC
I _{OZ}	3-state Leakage			20	μA	
DIOD8 Type Buffer						
V _{OL}	Low Output Voltage			0.4	V	I _{OL} = 8 mA
V _{IL}	Low Input Voltage			0.8	V	
V _{IH}	High Input Voltage	2.2			V	
I _{IL}	Low Input Leakage		10		μA	V _{IN} = 0
I _{IH}	High Input Leakage			-10	μA	V _{IN} = VCC
I _{OZ}	3-state Leakage			20	μA	

DC Electrical Characteristics (VCC = 5V ± 5%, Ta = 0°C to + 70°C) [cont'd]

Symbol	Parameter	Min.	Typ.	Max.	Unit	Conditions
DIO16 Type Buffer						
V _{OL}	Low Output Voltage			0.4	V	I _{OL} = 16 mA
V _{OH}	High Output Voltage	2.4			V	I _{OH} = -16 mA
V _{IL}	Low Input Voltage			0.8	V	
V _{IH}	High Input Voltage	2.2			V	
I _{IL}	Low Input Leakage		10		μA	V _{IN} = 0
I _{IH}	High Input Leakage			-10	μA	V _{IN} = VCC
I _{OZ}	3-state Leakage			20	μA	
DIOD16 Type Buffer						
V _{OL}	Low Output Voltage			0.4	V	I _{OL} = 16 mA
V _{IL}	Low Input Voltage			0.8	V	
V _{IH}	High Input Voltage	2.2			V	
I _{IL}	Low Input Leakage		10		μA	V _{IN} = 0
I _{IH}	High Input Leakage			-10	μA	V _{IN} = VCC
I _{OZ}	3-state Leakage			20	μA	
DIO24 Type Buffer						
V _{OL}	Low Output Voltage			0.4	V	I _{OL} = 24 mA
V _{OH}	High Output Voltage	2.4			V	I _{OH} = -24 mA
V _{IL}	Low Input Voltage			0.8	V	
V _{IH}	High Input Voltage	2.2			V	
I _{IL}	Low Input Leakage		10		μA	V _{IN} = 0
I _{IH}	High Input Leakage			-10	μA	V _{IN} = VCC
I _{OZ}	3-state Leakage			20	μA	
DI Type Buffer						
V _{IL}	Low Input Voltage			0.8	V	
V _{IH}	High Input Voltage	2.2			V	
I _{IL}	Low Input Leakage		10		μA	V _{IN} = 0
I _{IH}	High Input Leakage			-10	μA	V _{IN} = VCC

11. AC Characteristics (VCC = 5V ± 5%, Ta = 0°C to + 70°C)

11.1 Clock Input Timings

Symbol	Parameter	Min.	Typ.	Max.	Unit
t ₁	Clock High Pulse Width when CLKIN=48 MHz ¹	8			nsec
t ₂	Clock Low Pulse Width when CLKIN=48 MHz ¹	8			nsec
t ₃	Clock Period when CLKIN=48 MHz ¹	20	21	22	nsec
t ₄	Clock High Pulse Width when CLKIN=24 MHz ¹	18			nsec
t ₅	Clock Low Pulse Width when CLKIN=24 MHz ¹	18			nsec
t ₆	Clock Period when CLKIN=24 MHz ¹	40	42	44	nsec

Not tested. Guaranteed by design.

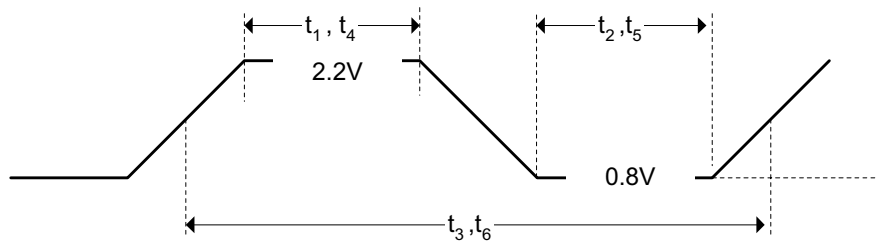

Figure 11-1. Clock Input Timings

11.2 LCLK (PCICLK) and LRESET Timings

Symbol	Parameter	Min.	Typ.	Max.	Unit
t ₁	LCLK Cycle Time	28			nsec
t ₂	LCLK High Time	11			nsec
t ₃	LCLK Low Time	11			nsec
t ₄	LRESET# Low Pulse Width	1.5			μsec

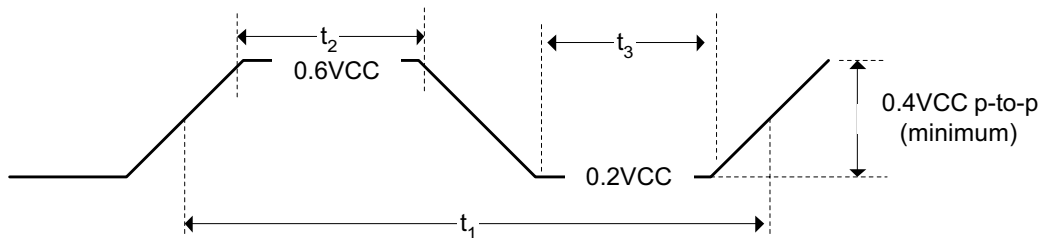

Figure 11-2. LCLK (PCICLK) and LRESET Timings

11.3 LPC and SERIRQ Timings

Symbol	Parameter	Min.	Typ.	Max.	Unit
t_1	Float to Active Delay	3			nsec
t_2	Output Valid Delay			12	nsec
t_3	Active to Float Delay			6	nsec
t_4	Input Setup Time	9			nsec
t_5	Input Hold Time	3			nsec

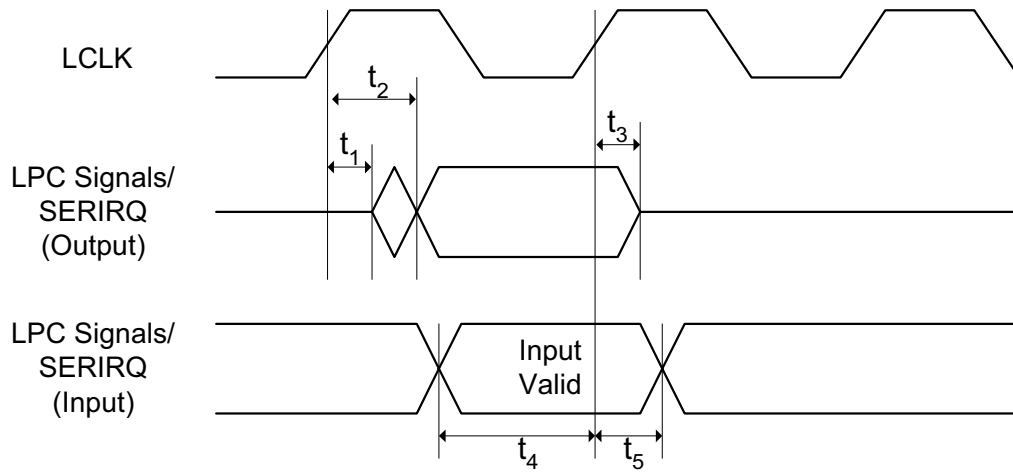

Figure 11-3. LPC and SERIRQ Timings

11.4 Serial Port, ASKIR, SIR and Consumer Remote Control Timings

Symbol	Parameter	Conditions	Min.	Max.	Unit
t ₁	Single Bit Time in Serial Port and ASKIR	Transmitter	t _{BTN} - 25 ^{Note1}	t _{BTN} + 25	nsec
		Receiver	t _{BTN} - 2%	t _{BTN} + 2%	nsec
t ₂	Modulation Signal Pulse Width in ASKIR	Transmitter	950	1050	nsec
		Receiver	500		nsec
t ₃	Modulation Signal Period in ASKIR	Transmitter	1975	2025	nsec
		Receiver	2000X(23/24)	2000X(25/24)	nsec
t ₄	SIR Signal Pulse Width	Transmitter, Variable	(3/16) x t _{BTN} - 25	(3/16) x t _{BTN} + 25	nsec
		Transmitter, Fixed	1.48	1.78	μsec
		Receiver	1		μsec

Note 1: t_{BTN} is the nominal bit time in Serial Port, ASKIR, and SIR. It is determined by the setting on the Baud Rate Divisor registers.

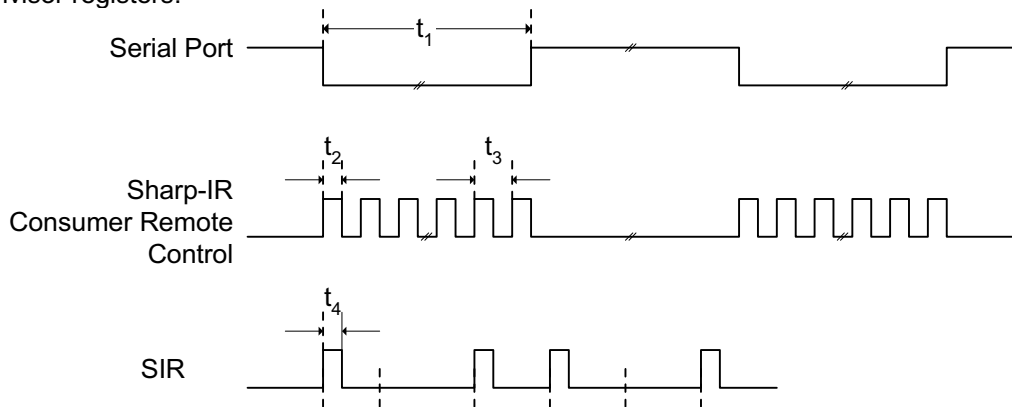

Figure 11-4. Serial Port, ASKIR, SIR and Consumer Remote Control Timings

11.5 Modem Control Timings

Symbol	Parameter	Min.	Typ.	Max.	Unit
t ₁	Float to active delay			40	nsec

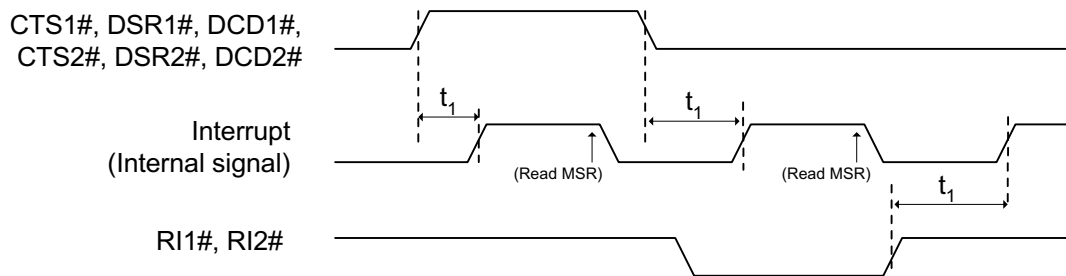

Figure 11-5. Modem Control Timings

11.6 Floppy Disk Drive Timings

Symbol	Parameter	Min.	Typ.	Max.	Unit
t ₁	DIR# active to STEP# low		4X t _{mclk} ^{Note1}		nsec
t ₂	STEP# active time (low)		24X t _{mclk}		nsec
t ₃	DIR# hold time after STEP#		t _{SRT} ^{Note2}		msec
t ₄	STEP# cycle time		t _{SRT}		msec
t ₅	INDEX# low pulse width	2X t _{mclk}			nsec
t ₆	RDATA# low pulse width	40			nsec
t ₇	WDATA# low pulse width		1X t _{mclk}		nsec

Note 1: t_{mclk} is the cycle of the main clock for the microcontroller of FDC. t_{mclk} = 8M/ 4M/ 2.4M/ 2M for 1M/ 500K/ 300K/ 250 Kbps transfer rates respectively.

Note 2: t_{SRT} is the cycle of the Step Rate Time. Please refer to the functional description of the SPECIFY command of the FDC.

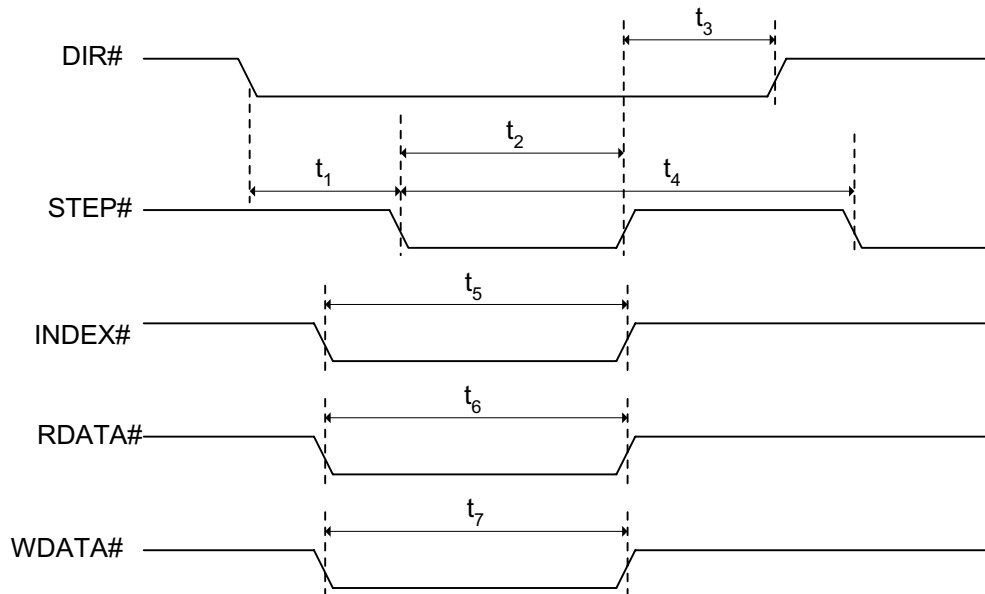

Figure 11-6. Floppy Disk Drive Timings

11.7 EPP Address or Data Write Cycle Timings

Symbol	Parameter	Min.	Typ.	Max.	Unit
t_1	WRITE# asserted to PD[7:0] valid			50	nsec
t_2	ASTB# or DSTB# asserted to WAIT# de-asserted	0		10	nsec
t_3	WAIT# de-asserted to ASTB# or DSTB# de-asserted	65		135	nsec
t_4	ASTB# or DSTB# de-asserted to WAIT# asserted	0			nsec
t_5	WAIT# asserted to WRITE# de-asserted	65			nsec
t_6	PD[7:0] invalid after WRITE# de-asserted	0			nsec

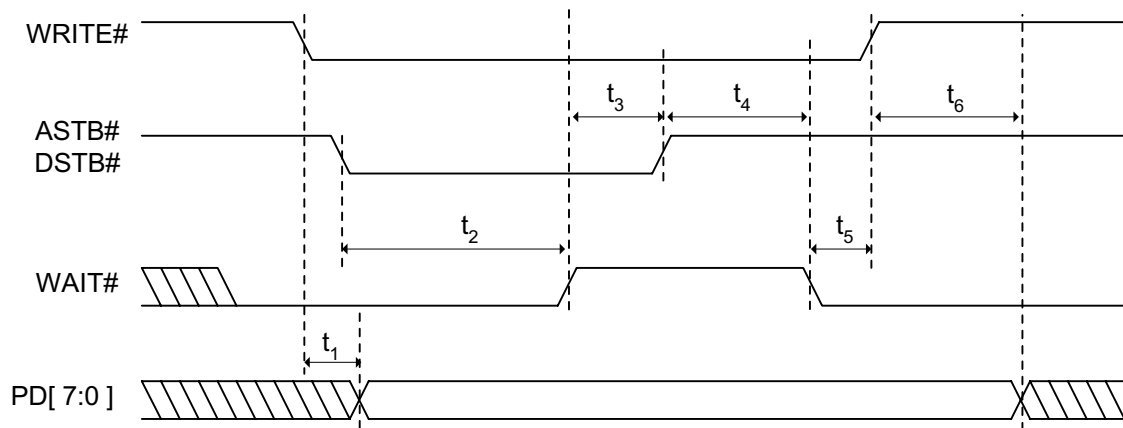

Figure 11-7. EPP Address or Data Write Cycle Timings

11.8 EPP Address or Data Read Cycle Timings

Symbol	Parameter	Min.	Typ.	Max.	Unit
t_1	ASTB# or DSTB# asserted to WAIT# de-asserted			10	nsec
t_2	ASTB# or DSTB# asserted to PD[7:0] Hi-Z	0			nsec
t_3	PD[7:0] valid to WAIT# de-asserted	0			nsec
t_4	WAIT# de-asserted to ASTB# or DSTB# de-asserted	65		135	nsec
t_5	ASTB# or DSTB# de-asserted to WAIT# asserted	0			nsec
t_6	PD[7:0] invalid after ASTB# or DSTB# de-asserted	20			nsec

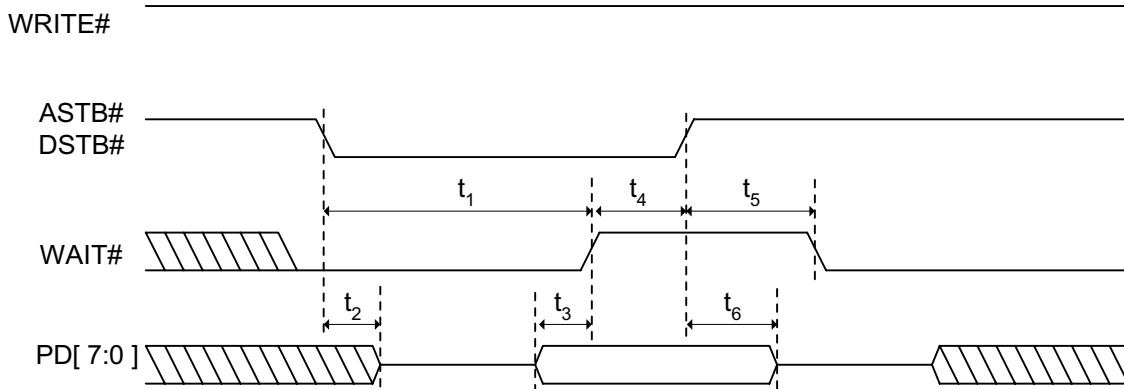

Figure 11-8. EPP Address or Data Read Cycle Timings

11.9 ECP Parallel Port Forward Timings

Symbol	Parameter	Min.	Typ.	Max.	Unit
t_1	PD[7:0] and nAutoFd valid to nStrobe asserted			50	nsec
t_2	nStrobe asserted to Busy asserted	0			nsec
t_3	Busy asserted to nStrobe de-asserted	70		170	nsec
t_4	nStrobe de-asserted to Busy de-asserted	0			nsec
t_5	Busy de-asserted to PD[7:0] and nAutoFd changed	80		180	nsec
t_6	Busy de-asserted to nStrobe asserted	70		170	nsec

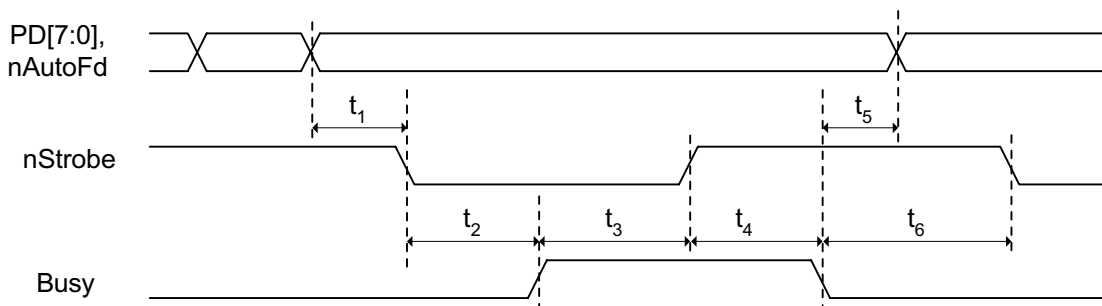

Figure 11-9. ECP Parallel Port Forward Timings

11.10 ECP Parallel Port Backward Timings

Symbol	Parameter	Min.	Typ.	Max.	Unit
t_1	PD[7:0] valid to nAck asserted	0			nsec
t_2	nAck asserted to nAutoFd asserted	70		170	nsec
t_3	nAutoFd asserted to nAck de-asserted	0			nsec
t_4	nAck de-asserted to nAutoFd de-asserted	70		170	nsec
t_5	nAutoFd de-asserted to PD[7:0] changed	0			nsec
t_6	nAutoFd de-asserted to nAck asserted	0			nsec

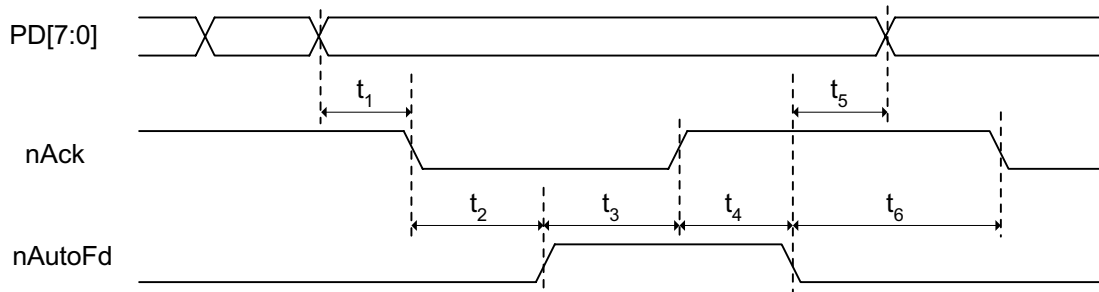
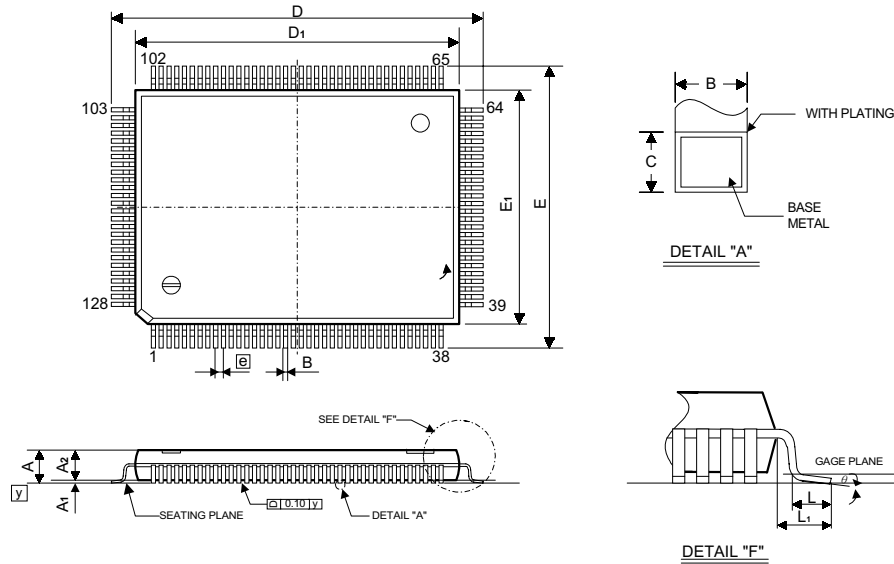

Figure 11-10. ECP Parallel Port Backward Timings

12. Package Information
QFP 128L Outline Dimensions

unit: inches/mm



Symbol	Dimension in inch			Dimension in mm		
	Min.	Nom.	Max.	Min.	Nom.	Max.
A	-	-	0.134	-	-	3.40
A1	0.010	-	-	0.25	-	-
A2	0.107	0.112	0.117	2.73	2.85	2.97
B	0.007	0.009	0.011	0.17	0.22	0.27
C	0.004	-	0.008	0.09	-	0.20
D	0.906	0.913	0.921	23.00	23.20	23.40
D ₁	0.783	0.787	0.791	19.90	20.00	20.10
E	0.669	0.677	0.685	17.00	17.20	17.40
E ₁	0.547	0.551	0.555	13.90	14.00	14.10
e	0.020 BSC			0.5 BSC		
L	0.029	0.035	0.041	0.73	0.88	1.03
L ₁	0.063 BSC			1.60 BSC		
y	-	-	0.004	-	-	0.10
θ	0°	-	7°	0°	-	7°

Notes:

1. Dimensions D₁ and E₁ do not include mold protrusion, but mold mismatch is included.
2. Dimension B does not include dambar protrusion.
3. Controlling dimension: millimeter.

13. Ordering Information

Part No.	Package
IT8722F	128 QFP