

CHIP RESISTORS

1005(0402) / 1608(0603) / 2012(0805) Series

Features

1. Small size and light weight
2. High reliability and stability
3. Suitable for both reflow soldering and wave soldering
4. Low noise

Applications

Any general circuit of portable equipment which compact size and high mounting densities are required.

Ordering Information

CODE : WR04 X 103 J T
(1) (2) (3) (4) (5)

(1) Size Code

WR08 : 2012(0805)
WR06 : 1608(0603)
WR04 : 1005(0402)

(2) Tape Code

X : Normal
Y : Special order

(3) Resistance Code

E24 : Two significant digits
followed by no.of zeros
4.7 Ω = 4R7
10 Ω = 100
220 Ω = 221
Jump = 000

(4) Tolerance

F = $\pm 1\%$
G = $\pm 2\%$
J = $\pm 5\%$
P = Jumper

(5) Packaging Code

No Code = Bulk
T = Reel

E96 : Two significant digits
followed by no.of zeros
102 Ω = 1020
37.4k Ω = 3742
WR04 : No marking

Shape and Dimensions

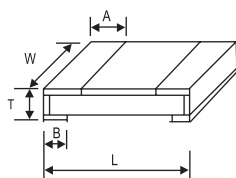

unit:mm

Size	L	W	A	B	T
WR08	2.0 \pm 0.1	1.25 \pm 0.1	0.4 \pm 0.2	0.4 \pm 0.2	0.5 \pm 0.15
WR06	1.6 \pm 0.1	0.8 \pm 0.1	0.3 \pm 0.1	0.3 \pm 0.2	0.45 \pm 0.15
WR04	1.0 \pm 0.05	0.5 \pm 0.05	0.2 \pm 0.1	0.25 \pm 0.1	0.35 \pm 0.05

Power Derating

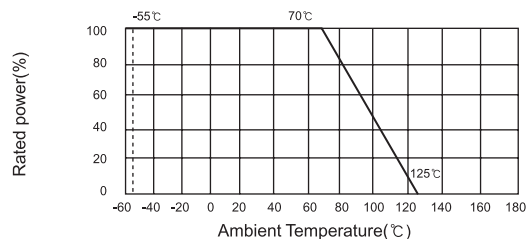

For resistors operated in ambient temperatures above 70°C, power rating must be derated according to the graph(left).

Ratings

Series No	Power rating at 70°C	TCR (ppm/°C)	Max RCWV (Note1)	Max Overload Voltage	Resistance Tolerance(±%)	Resistance Range(Note2)	Standard Res. Values	Working Temperature Range(°C)
WR08	1/8W	±100	100V	200V	1	10 Ω ~ 1M Ω	E-96	-55 ~ 125°C
		±200	100V	200V	5	1 Ω ~ 10M Ω	E-24	
WR06	1/10W	±100	50V	100V	1	10 Ω ~ 1M Ω	E-96	
		±200	50V	100V	5	1 Ω ~ 10M Ω	E-24	
WR04	1/16W	±200	50V	100V	1	6.8 Ω ~ 2.2M Ω	E-96	
		±200	50V	100V	2,5	6.8 Ω ~ 2.2M Ω	E-24	

Note1. RCWV (Rated Continuous Working Voltage) is determined by
 $RCWV = \sqrt{\text{Rated power} \times \text{Resistance Value}}$, or Max. RCWV listed above, whichever is lower.
 Note2. Resistance value other than specified range is also available.
 Note3. E-96 is only available for 1% tolerance.

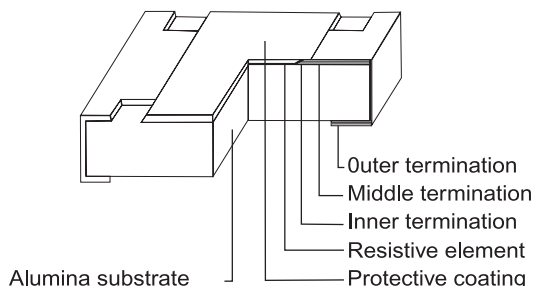

1. Outer termination : solder plated (Over 4 μ m).
2. Middle termination : Nickel plated (2 μ m ~ 6 μ m).
3. Inner termination : Ag layer.

Tests and Specifications

Test Item	Specification		Test Method															
	Chip Resistor	Jumper																
DC Resistance	With the specified tolerance		50m \varnothing lower JIS C 5202 5.1 DC Resistance values measured at the test voltages specified below : <table border="1"> <tr> <th>Resistance nominal</th> <th>Test voltage</th> </tr> <tr> <td>< 100\varnothing</td> <td>0.3V</td> </tr> <tr> <td>< 1k\varnothing</td> <td>1V</td> </tr> <tr> <td>< 10k\varnothing</td> <td>3V</td> </tr> <tr> <td>< 100k\varnothing</td> <td>10V</td> </tr> <tr> <td>< 1M\varnothing</td> <td>25V</td> </tr> <tr> <td>> 10M\varnothing</td> <td>50V</td> </tr> </table>	Resistance nominal	Test voltage	< 100 \varnothing	0.3V	< 1k \varnothing	1V	< 10k \varnothing	3V	< 100k \varnothing	10V	< 1M \varnothing	25V	> 10M \varnothing	50V	
Resistance nominal	Test voltage																	
< 100 \varnothing	0.3V																	
< 1k \varnothing	1V																	
< 10k \varnothing	3V																	
< 100k \varnothing	10V																	
< 1M \varnothing	25V																	
> 10M \varnothing	50V																	
Temperature Coefficient of Resistance (TCR)	WR08 $\pm 100\text{ppm}/^\circ\text{C}$ for F product, $\pm 200\text{ppm}/^\circ\text{C}$ for J product. WR06 -300~+500ppm/ $^\circ\text{C}$ for R < 10 \varnothing WR04 0 ~ 500ppm/ $^\circ\text{C}$ for R \leq 10 \varnothing $\pm 200\text{ppm}/^\circ\text{C}$ for R > 10 \varnothing	-	JIS C 5202 5.2 / IEC 115-1 4.8.4.2 Natural resistance change per temperature degree centigrade $\text{TCR}(\text{ppm}/^\circ\text{C}) = \frac{R_2 - R_1}{R_1(t_2 - t_1)} \times 10^6$ R ₁ : Resistance value at reference temperature R ₂ : Resistance value at test temperature t ₁ : Room temperature, t ₂ : Test temperature															
Short Time Overload (STOL)	$\pm(2\%+0.1\varnothing)$	50m \varnothing lower	JIS C 5202 5.5 / IEC 115-1 4.13 Permanent resistance change after a 5 second application of a voltage 2.5 times RCWV or the maximum overload voltage specified in the above list, whichever is less.															
Resistance to Solder Heat	$\pm(1\%+0.05\varnothing)$	50m \varnothing lower	JIS C 5202 6.4 / IEC 115-1 4.18 With 260 $^\circ\text{C} \pm 5^\circ\text{C}$ for 10 ± 1 second.															
Solderability	95% coverage min	-	JIS C 5202 6.5 / IEC 115-1 4.17 After immersing flux, dip in the 235 $^\circ\text{C} \pm 5^\circ\text{C}$ molten solder bath for 2 ± 0.5 second.															
Temperature Cycle	WR08 $\pm(1\%+0.1\varnothing)$ WR06 $\pm(1\%+0.1\varnothing)$ WR04 $\pm(2\%+0.1\varnothing)$	50m \varnothing lower	JIS C 5202 7.4 / IEC 115-1 4.19 Resistance change after continuous 5cycle for duty cycle are specified below : <table border="1"> <thead> <tr> <th>Step</th> <th>Temperature</th> <th>Time</th> </tr> </thead> <tbody> <tr> <td>1</td> <td>-55$^\circ\text{C} \pm 3^\circ\text{C}$</td> <td>30min</td> </tr> <tr> <td>2</td> <td>Normal</td> <td>2~3min</td> </tr> <tr> <td>3</td> <td>+125$^\circ\text{C} \pm 3^\circ\text{C}$</td> <td>30min</td> </tr> <tr> <td>4</td> <td>Normal</td> <td>2~3min</td> </tr> </tbody> </table>	Step	Temperature	Time	1	-55 $^\circ\text{C} \pm 3^\circ\text{C}$	30min	2	Normal	2~3min	3	+125 $^\circ\text{C} \pm 3^\circ\text{C}$	30min	4	Normal	2~3min
Step	Temperature	Time																
1	-55 $^\circ\text{C} \pm 3^\circ\text{C}$	30min																
2	Normal	2~3min																
3	+125 $^\circ\text{C} \pm 3^\circ\text{C}$	30min																
4	Normal	2~3min																
Load Life in Humidity	WR08 $\pm(3\%+0.1\varnothing)$ for 10 $\varnothing \leq R < 1M\varnothing$ $\pm(5\%+0.1\varnothing)$ for R < 10 \varnothing $R \geq 1M\varnothing$ WR06 $\pm(3\%+0.1\varnothing)$ WR04 (1%) $\pm(2\%+0.1\varnothing)$ WR04 (2%, 5%) $\pm(3\%+0.1\varnothing)$	50m \varnothing lower	JIS C 5202 7.9 / IEC 115-1 4.24.2 Resistance change after 1000+48/-0 hours, 1.5 hours 「ON」, 0.5hour 「OFF」, at RCWV in a humidity chamber controlled at 40 $^\circ\text{C} \pm 2^\circ\text{C}$ and 90%~95% relative humidity															
Load Life	WR08 $\pm(3\%+0.1\varnothing)$ for 10 $\varnothing \leq R < 1M\varnothing$ $\pm(5\%+0.1\varnothing)$ for R < 10 \varnothing $R \geq 1M\varnothing$ WR06 $\pm(3\%+0.1\varnothing)$ WR04 (1%) $\pm(2\%+0.1\varnothing)$ WR04 (2%, 5%) $\pm(3\%+0.1\varnothing)$	50m \varnothing lower	JIS C 5202 7.10 / IEC 115-1 4.25.1 Permanent resistance change after 1000+48/-0 hours, operating at RCWV with duty cycle of 1.5 hours 「ON」, 0.5hour 「OFF」, at 70 $^\circ\text{C} \pm 2^\circ\text{C}$ ambient.															
Terminal Strength	$\pm(1\%+0.05\varnothing)$ no evidence of mechanical damage	50m \varnothing lower	JIS C 5202 6.1.4 / IEC 115-1 4.33 Bending test : at Y/X = 3mm/90mm, one time, 10 seconds. Pulling test : 500 grams.															

CHIP RESISTORS

Packaging & Reel Dimension

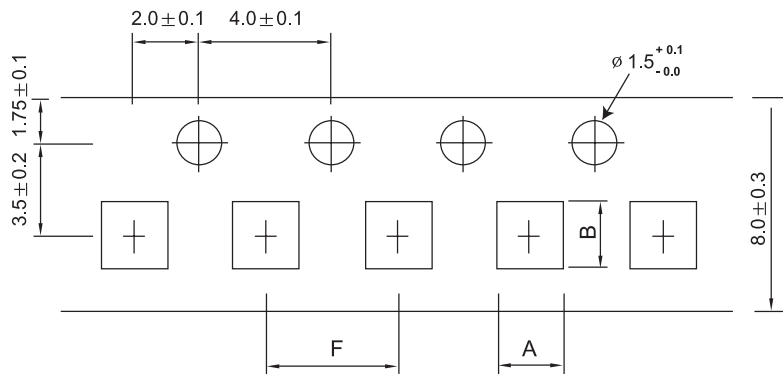

Unit : mm

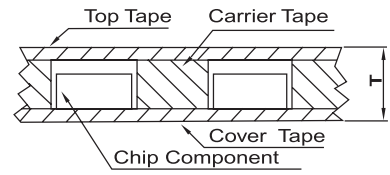

Reel Dimension(mm)

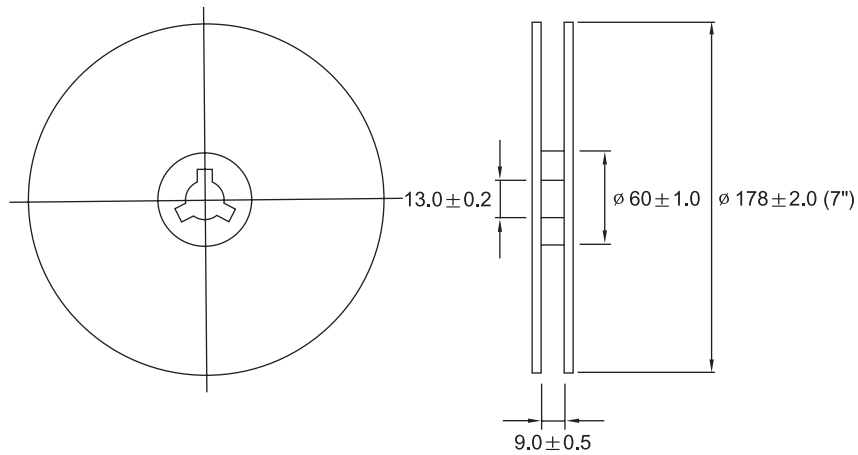

	A	B	F	T
WR08	1.65±0.2	2.4±0.2	4.0±0.1	1.0MAX
WR06	1.1±0.2	1.9±0.2	4.0±0.1	1.0MAX
WR04	0.7±0.05	1.2±0.05	2.0±0.1	0.4±0.05

Size	Tape Material	Tape Width	Pcs/Reel
WR06,08	paper	8mm	5,000
WR04	paper	8mm	10,000