

QUAD EIA-422/423 Line Receiver with Three-State Outputs

Motorola's Quad EIA-422/3 Receiver features four independent receiver chains which comply with EIA Standards for the Electrical Characteristics of Balanced/Unbalanced Voltage Digital Interface Circuits. Receiver outputs are 74LS compatible, three-state structures which are forced to a high impedance state when Pin 4 is a Logic "0" and Pin 12 is a Logic "1." A PNP device buffers each output control pin to assure minimum loading for either Logic "1" or Logic "0" inputs. In addition, each receiver chain has internal hysteresis circuitry to improve noise margin and discourage output instability for slowly changing input waveforms. A summary of AM26LS32 features include:

- Four Independent Receiver Chains
- Three-State Outputs
- High Impedance Output Control Inputs (PIA Compatible)
- Internal Hysteresis – 30 mV (Typical) @ Zero Volts Common Mode
- Fast Propagation Times – 25 ns (Typical)
- TTL Compatible
- Single 5.0 V Supply Voltage
- Fail-Safe Input-Output Relationship. Output Always High When Inputs Are Open, Terminated or Shorted
- 6.0 k Minimum Input Impedance

AM26LS32

QUAD EIA-422/3 LINE RECEIVER WITH THREE-STATE OUTPUTS

SEMICONDUCTOR TECHNICAL DATA

D SUFFIX
PLASTIC PACKAGE
CASE 7518
(SO-16)

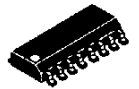

PC SUFFIX
PLASTIC PACKAGE
CASE 648

Representative Block Diagram

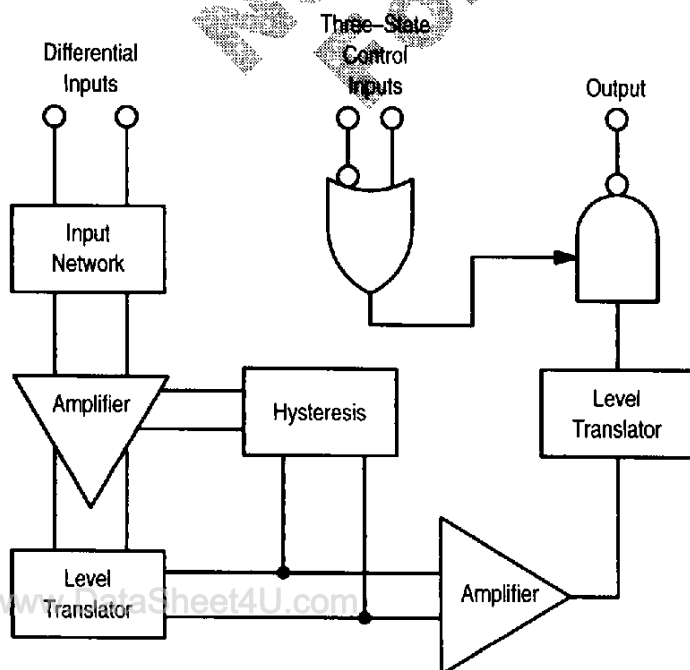

PIN CONNECTIONS

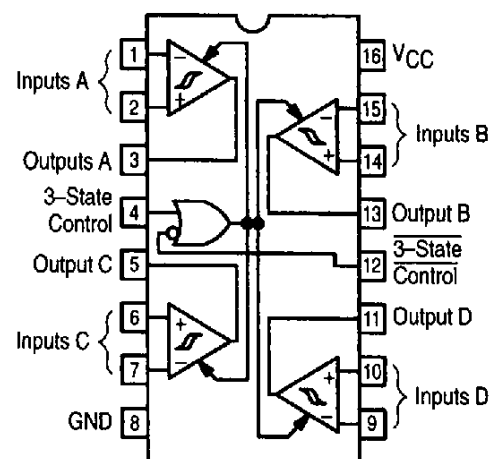

ORDERING INFORMATION

Device	Operating Temperature Range	Package
AM26LS32PC	T _A = 0 to 70°C	Plastic DIP
MC26LS32D*		SO-16

* Note that the surface mount MC26LS32D device uses the same die as in the plastic DIP AM26LS32DC device, but with an MC prefix to prevent confusion with the package suffix.

AM26LS32

MAXIMUM RATINGS

Rating	Symbol	Value	Unit
Power Supply Voltage	V_{CC}	7.0	Vdc
Input Common Mode Voltage	V_{ICM}	± 25	Vdc
Input Differential Voltage	V_{ID}	± 25	Vdc
Three-State Control Input Voltage	V_I	7.0	Vdc
Output Sink Current	I_O	50	mA
Storage Temperature	T_{stg}	-65 to +150	°C
Operating Junction Temperature	T_J	+150	°C

RECOMMENDED OPERATING CONDITIONS

Rating	Symbol	Value	Unit
Power Supply Voltage	V_{CC}	4.75 to 5.25	Vdc
Operating Ambient Temperature	T_A	0 to +70	°C
Input Common Mode Voltage Range	V_{ICR}	-7.0 to +7.0	Vdc
Input Differential Voltage Range	V_{IDR}	6.0	Vdc

ELECTRICAL CHARACTERISTICS (Unless otherwise noted, minimum and maximum limits apply over recommended temperature and power supply voltage ranges. Typical values are for $T_A = 25^\circ\text{C}$, $V_{CC} = 5.0\text{ V}$ and $V_{IC} = 0\text{ V}$. See Note 1.)

Characteristic	Symbol	Min	Typ	Max	Unit
Input Voltage – High Logic State (Three-State Control)	V_{IH}	2.0	–	–	V
Input Voltage – Low Logic State (Three-State Control)	V_{IL}	–	–	0.8	V
Differential Input Threshold Voltage (Note 2) ($-7.0\text{ V} \leq V_{IC} \leq 7.0\text{ V}$, $V_{IH} = 2.0\text{ V}$) ($I_O = -0.4\text{ mA}$, $V_{OH} \geq 2.7\text{ V}$) ($I_O = 8.0\text{ mA}$, $V_{OL} \leq 0.45\text{ V}$)	$V_{TH(D)}$	–	–	0.2 -0.2	V
Input Bias Current ($V_{CC} = 0\text{ V}$ or 5.25) (Other Inputs at $-15\text{ V} \leq V_{in} \leq +15\text{ V}$) $V_{in} = +15\text{ V}$ $V_{in} = -15\text{ V}$	$I_{IB(D)}$	–	–	2.3 -2.8	mA
Input Resistance ($-15\text{ V} \leq V_{in} \leq +15\text{ V}$)	R_{in}	6.0 K	–	–	Ohms
Input Balance and Output Level ($-7.0\text{ V} \leq V_{IC} \leq 7.0\text{ V}$, $V_{IH} = 2.0\text{ V}$, See Note 3) ($I_O = -0.4\text{ mA}$, $V_{ID} = 0.4\text{ V}$) ($I_O = 8.0\text{ mA}$, $V_{ID} = -0.4\text{ V}$)	V_{OH} V_{OL}	2.7 –	– –	– 0.45	V
Output Third State Leakage Current ($V_{I(D)} = +3.0\text{ V}$, $V_{IL} = 0.8\text{ V}$, $V_O = 0.4\text{ V}$) ($V_{I(D)} = -3.0\text{ V}$, $V_{IL} = 0.8\text{ V}$, $V_O = 2.4\text{ V}$)	I_{OZ}	–	–	-20 20	μA
Output Short Circuit Current ($V_{I(D)} = 3.0\text{ V}$, $V_{IH} = 2.0\text{ V}$, $V_O = 0\text{ V}$, See Note 4)	I_{OS}	-15	–	-85	mA
Input Current – Low Logic State (Three-State Control) ($V_{IL} = 0.4\text{ V}$)	I_{IL}	–	–	-360	μA
Input Current – High Logic State (Three-State Control) ($V_{IH} = 2.7\text{ V}$) ($V_{IH} = 5.5\text{ V}$)	I_{IH}	–	–	20 100	μA
Input Clamp Diode Voltage (Three-State Control) ($I_{IC} = -18\text{ mA}$)	V_{IK}	–	–	-1.5	V
Power Supply Current ($V_{IL} = 0\text{ V}$) (All Inputs Grounded)	I_{CC}	–	–	70	mA

- NOTES:**
- All currents into device pins are shown as positive, out of device pins are negative. All voltages referenced to ground unless otherwise noted.
 - Differential input threshold voltage and guaranteed output levels are done simultaneously for worst case.
 - Refer to EIA-422/3 for exact conditions. Input balance and guaranteed output levels are done simultaneously for worst case.
 - Only one output at a time should be shorted.

AM26LS32

SWITCHING CHARACTERISTICS ($V_{CC} = 5.0 \text{ V}$ and $T_A = 25^\circ\text{C}$, unless otherwise noted)

Characteristic	Symbol	Min	Typ	Max	Unit
Propagation Delay Time – Differential Inputs to Output (Output High to Low) (Output Low to High)	$t_{PHL(D)}$	–	–	30	ns
	$t_{PLH(D)}$	–	–	30	ns
Propagation Delay Time – Three–State Control to Output (Output Low to Third State) (Output High to Third State) (Output Third State to High) (Output Third State to Low)	t_{PLZ}	–	–	35	ns
	t_{PHZ}	–	–	35	ns
	t_{PZH}	–	–	30	ns
	t_{PZL}	–	–	30	ns

Figure 1. Switching Test Circuit and Wave for Propagation Delay Differential Input to Output

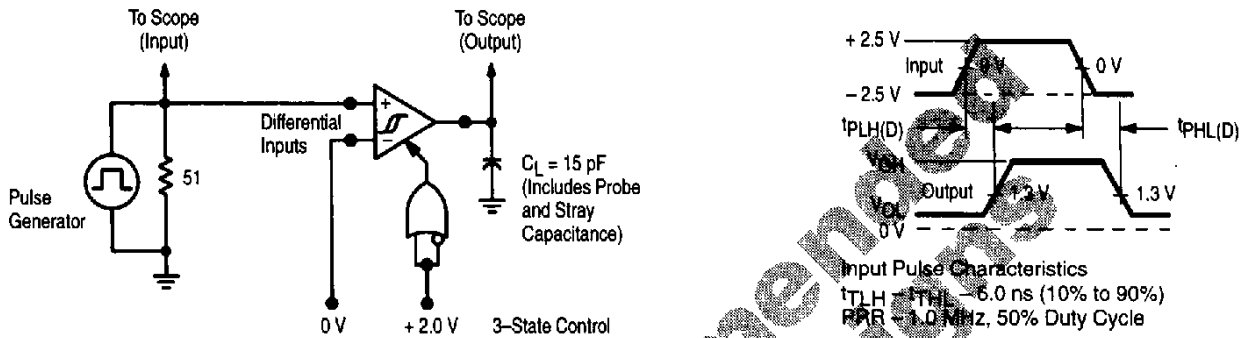

Figure 2. Propagation Delay Three–State Control Input to Output

