

www.DataSheet4U.com
 Powerex, Inc., Hillis Street, Youngwood, Pennsylvania 15697 (412) 925-7272
 Powerex, Europe, S.A. 426 Avenue G. Durand, BP107, 72003 Le Mans, France (43) 41.14.14

Intellimod™-3 Modules

Single Phase
 IGBT Inverter Output
 200 Amperes/460 Volt Line

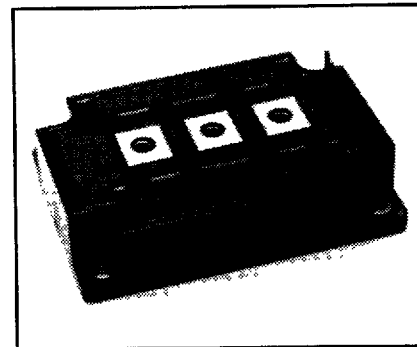
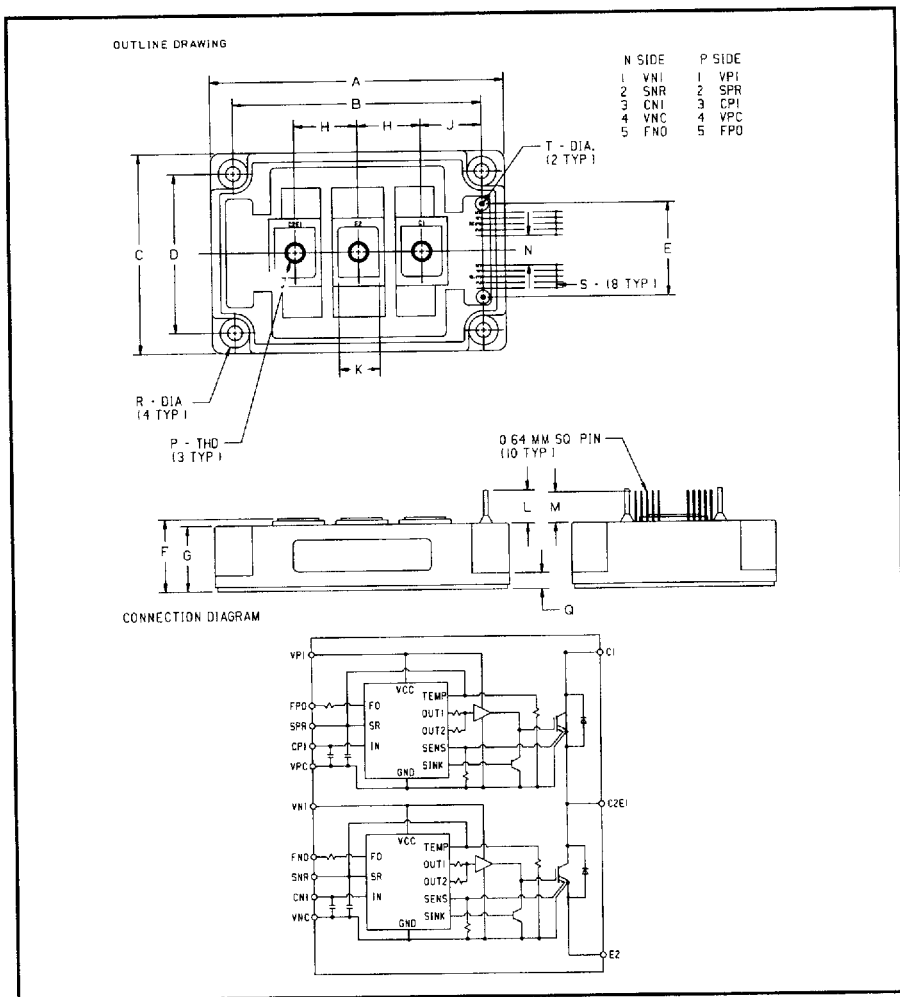

Description

Powerex Intellimod-3 Modules are designed for applications requiring a high frequency (20kHz) output switching inverter. The modules are isolated from the baseplate, consisting of complete drive, control and protection circuitry for the IGBT inverter.

Features:

- Complete Output Power Circuit
- Gate Drive Circuit
- Protection Logic
 - Short Circuit
 - Over-Current
 - Over Temperature
 - Under Voltage

Applications:

- Inverters
- Small UPS
- Motion/Servo Control
- AC Motor Control

Ordering Information

PM200DHA120

460 Volt Line, PM200DHA120 Outline Drawing

| Dimensions | Inches | Millimeters |
|------------|-----------------|---------------|
| A | 5.12 | 130.0 |
| B | 4.33±0.10 | 110.0±0.25 |
| C | 3.54 | 90.0 |
| D | 2.76±0.10 | 70.0±0.25 |
| E | 1.61 | 41.0 |
| F | 1.34+0.04/-0.02 | 34.0+1.0/-0.5 |
| G | 1.22 | 31.0 |
| H | 1.1 | 28.0 |
| J | 1.06 | 27.0 |

| Dimensions | Inches | Millimeters |
|------------|-----------|-------------|
| K | 0.71 | 18.0 |
| L | 0.57 | 14.5 |
| M | 0.53 | 13.5 |
| N | 0.51 | 13.0 |
| P | Metric M8 | M8 |
| Q | 0.28 | 7.0 |
| R | 0.26 Dia. | 6.5 Dia. |
| S | 0.1 | 2.54 |
| T | 0.8 Dia. | 2.0 Dia. |



POWEREX INC

51E D ■ 7294621 0005785 T7T ■ PRX

Powerex, Inc., Hillis Street, Youngwood, Pennsylvania 15697 (412) 925-7272

Powerex, Europe, S.A. 428 Avenue G. Durand, BP107, 72003 Le Mans, France (43) 41.14.14

PM200DHA120

Intellimod-3 Modules

Single Phase IGBT Inverter Output

200 Amperes/460 Volt Line

T-57-29

Absolute Maximum Ratings, $T_j = 25\text{ }^\circ\text{C}$ unless otherwise specified

| Characteristics | Symbol | PM200DHA120 | Units |
|--|----------------|-------------|------------------|
| Power Device Junction Temperature | T_j | -20 to +150 | $^\circ\text{C}$ |
| Storage Temperature | T_{STG} | -40 to +125 | $^\circ\text{C}$ |
| Case Operating Temperature | T_C | -20 to +100 | $^\circ\text{C}$ |
| Mounting Torque, M6 Mounting Screws | — | 30 | Kg-cm |
| Mounting Torque, M8 Main Terminal Screws | — | 110 | Kg-cm |
| Module Weight (Typical) | — | 910 | Grams |
| Supply Voltage Protected by OC and SC ($V_D = 13.5 - 16.5\text{V}$, Inverter Part) | $V_{CC(prot)}$ | 800 | Volts |
| Isolation Voltage AC 1 minute, 60Hz | V_{RMS} | 2500 | Volts |

Control Sector

| | | | |
|--|-----------|----|-------|
| Supply Voltage Applied between ($V_{P1} - V_{PC}, V_{N1} - V_{NC}$) | V_D | 20 | Volts |
| Input Voltage Applied between ($C_{P1} - V_{PC}, C_{N1} - V_{NC}$) | V_{CIN} | 10 | Volts |
| Fault Output Supply Voltage Applied between ($F_{PO} - V_{PC}, F_{NO} - V_{NC}$) | V_{FO} | 20 | Volts |
| Fault Output Current (Sink Current at F_{PO}, F_{NO} Terminals) | I_{FO} | 20 | mA |

IGBT Inverter Sector

| | | | |
|--|-----------------|------|---------|
| Collector-Emitter Voltage | V_{CES} | 1200 | Volts |
| Collector Current \pm | I_C | 200 | Amperes |
| Peak Collector Current \pm | I_{CP} | 400 | Amperes |
| Supply Voltage (Applied between P - N) | V_{CC} | 900 | Volts |
| Supply Voltage (Surge) Applied between P - N | $V_{CC(surge)}$ | 1000 | Volts |
| Collector Dissipation | P_C | 1470 | Watts |



www.powerex.com

POWEREX INC

51E D ■ 7294621 0005786 906 ■ PRX

Powerex, Inc., Hillis Street, Youngwood, Pennsylvania 15697 (412) 925-7272
 Powerex, Europe, S.A. 428 Avenue G. Durand, BP107, 72003 Le Mans, France (43) 41.14.14

T-57-29

PM200DHA120
 Intellimod-3 Modules
 Single Phase IGBT Inverter Output
 200 Amperes/460 Volt Line

Electrical Characteristics, $T_j = 25^\circ\text{C}$ unless otherwise specified

| Characteristics | Symbol | Test Conditions | Min. | Typ. | Max. | Units |
|---|----------------|---|------|------|------|------------------|
| Control Sector | | | | | | |
| Overcurrent Trip Level | OC | $-20^\circ\text{C} \leq T \leq 125^\circ\text{C}$, Fig. 5 | 240 | 360 | – | Amperes |
| Short Circuit Trip Level | SC | $-20^\circ\text{C} \leq T \leq 125^\circ\text{C}$, Fig. 5 | 320 | 540 | – | Amperes |
| Over Current Delay Time | $t_{off(OC)}$ | $V_D = 15\text{V}$, Fig. 5 | – | 5 | – | μS |
| Over Temperature Protection | OT | Trip Level | 100 | 110 | 120 | $^\circ\text{C}$ |
| Over Temperature Protection | OT_R | Reset Level | 85 | 95 | 105 | $^\circ\text{C}$ |
| Supply Circuit Under Voltage Protection | UV | Trip Level | 11.5 | 12.0 | 12.5 | Volts |
| Supply Circuit Under Voltage Protection | UV_R | Reset Level | – | 12.5 | – | Volts |
| Supply Voltage | V_D | Applied between $V_{P1} - V_{PC}, V_{N1} - V_{NC}$ | 13.5 | 15 | 16.5 | Volts |
| Circuit Current | I_D | $V_D = 15\text{V}, V_{CIN} = 5\text{V}, V_{N1} - V_{NC}$ | – | 23 | 30 | mA |
| | I_D | $V_D = 15\text{V}, V_{CIN} = 5\text{V}, V_{P1} - V_{PC}$ | – | 23 | 30 | mA |
| Input On Voltage | $V_{CIN(on)}$ | Applied between $C_{P1} - V_{PC}, C_{N1} - V_{NC}$ | 1.2 | 1.5 | 1.8 | Volts |
| Input Off Voltage | $V_{CIN(off)}$ | | 1.7 | 2.0 | 2.3 | Volts |
| PWM Input Frequency | f_{PWM} | 3- \emptyset Sinusoidal | – | 15 | 20 | kHz |
| Dead Time | t_{DEAD} | For each Input Pulse | 4.0 | – | – | μS |
| | | Using example Interface Circuit* | 6.0 | – | – | μS |
| Fault Output Current | $I_{FO(H)}$ | $V_D = 15\text{V}, V_{FO} = 15\text{V}$ | – | – | 0.01 | mA |
| | $I_{FO(L)}$ | $V_D = 15\text{V}, V_{FO} = 15\text{V}$ | – | 10 | 15 | mA |
| Minimum Fault Output Pulse Width | t_{FO} | $V_D = 15\text{V}$ | 1.0 | 1.8 | – | mS |
| SXR Terminal Output Voltage | V_{SXR} | $T_j = 125^\circ\text{C}, R_{IN} = 6.8\text{k}\Omega, (S_{PR}, S_{NR})$ | 4.5 | 5.1 | 5.6 | Volts |

*See Intellimod-3 Applications Data Section 4.3.



www.POWEREX.INC.com

51E D ■ 7294621 0005787 842 ■ PRX

Powerex, Inc., Hillis Street, Youngwood, Pennsylvania 15697 (412) 925-7272

Powerex, Europe, S.A. 428 Avenue G. Durand, BP107, 72003 Le Mans, France (43) 41.14.14

T-57-29

PM200DHA120

Intellimod-3 Modules

Single Phase IGBT Inverter Output

200 Amperes/460 Volt Line

Electrical Characteristics, $T_J = 25^\circ\text{C}$ unless otherwise specified

| Characteristics | Symbol | Test Conditions | Min. | Typ. | Max. | Units |
|--------------------------------------|---------------|---|------|------|------|---------------|
| IGBT Inverter Sector | | | | | | |
| Collector Cutoff Current | I_{CEX} | $V_{CE} = V_{CES}, T_J = 25^\circ\text{C}$, Fig. 4 | – | – | 1 | mA |
| Collector Cutoff Current | I_{CEX} | $V_{CE} = V_{CES}, T_J = 125^\circ\text{C}$, Fig. 4 | – | – | 10.0 | mA |
| Diode Forward Voltage | V_{FM} | $-I_C = 200\text{A}, V_{CIN} = 5\text{V}$, Fig. 2 | – | 1.8 | 3.0 | Volts |
| Collector Emitter Saturation Voltage | $V_{CE(sat)}$ | $V_D = 15\text{V}, V_{CIN} = 0\text{V}, I_C = 200\text{A}$, Fig. 1 | – | 2.8 | 3.8 | Volts |
| Collector Emitter Saturation Voltage | $V_{CE(sat)}$ | $V_D = 15\text{V}, V_{CIN} = 0\text{V}, I_C = 200\text{A}$, $T_J = 125^\circ\text{C}$, Fig. 1 | – | 2.4 | 3.4 | Volts |
| Inductive Load Switching Times | t_{on} | $V_D = 15\text{V}, V_{CIN} = 0\text{V}$, $V_{CC} = 600\text{V}, I_C = 200\text{A}$, $T_J = 125^\circ\text{C}$ Fig. 3 | 0.5 | 1.4 | 2.5 | μS |
| | t_{tr} | | – | 0.3 | 0.6 | μS |
| | $t_{C(on)}$ | | – | 0.4 | 1.0 | μS |
| | t_{off} | | – | 3.5 | 4.0 | μS |
| | $t_{C(off)}$ | | – | 0.8 | 1.2 | μS |

Thermal Characteristics

| Characteristics | Symbol | Test Conditions | Min. | Typ. | Max. | Units |
|--------------------------------------|----------------|-------------------------------------|------|------|-------|--------------------|
| Thermal Resistances Junction to Case | $R_{th(l-c)Q}$ | Inverter IGBT | – | – | 0.085 | $^\circ\text{C/W}$ |
| | $R_{th(l-c)F}$ | Inverter FWD | – | – | 0.18 | $^\circ\text{C/W}$ |
| Contact Thermal Resistance | $R_{th(c-f)}$ | Case to Fin, Thermal Grease Applied | – | – | 0.060 | $^\circ\text{C/W}$ |

Recommended Operating Conditions

| Characteristics | Symbol | Test Conditions | Value | Units |
|---------------------|----------------|---|---------------|---------------|
| Supply Voltage | V_{CC} | Applied across C1 - E2 Terminals | 0 ~ 800 | Volts |
| | V_D | Applied between $V_{P1} - V_{PC}, V_{N1} - V_{NC}$ | 15±1.5 | Volts |
| Input On Voltage | $V_{CIN(on)}$ | Applied between | 0 ~ 0.8 | Volts |
| Input Off Voltage | $V_{CIN(off)}$ | $C_{P1} - V_{PC}, C_{N1} - V_{NC}$ | 4 ~ V_{SXR} | Volts |
| PWM Input Frequency | f_{PWM} | Using example Interface Circuit* | 5 ~ 20 | kHz |
| Minimum Dead Time | t_{DEAD} | Using example Interface Circuit* | 6.0 | μS |

*See Intellimod-3 Applications Data Section 4.3.

www.DataSheet4U.com

T-57-2

PM200DHA120

Intellimod-3 Modules

Single Phase IGBT Inverter Output

200 Amperes/460 Volt Line

A) LOWER ARM SWITCHING

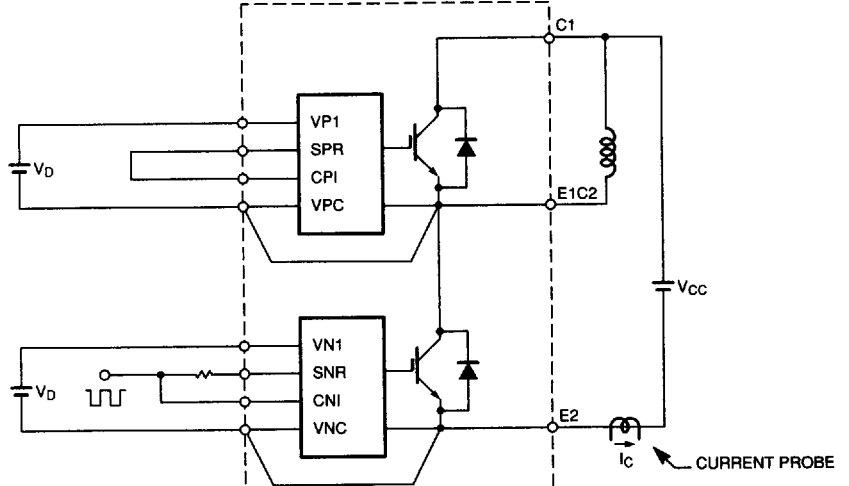

B) UPPER ARM SWITCHING

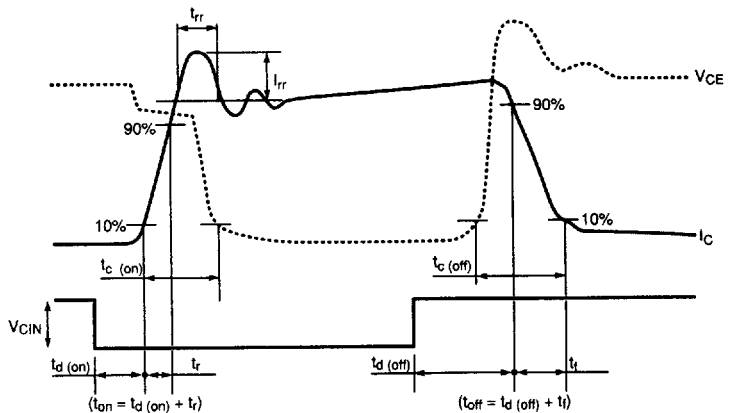
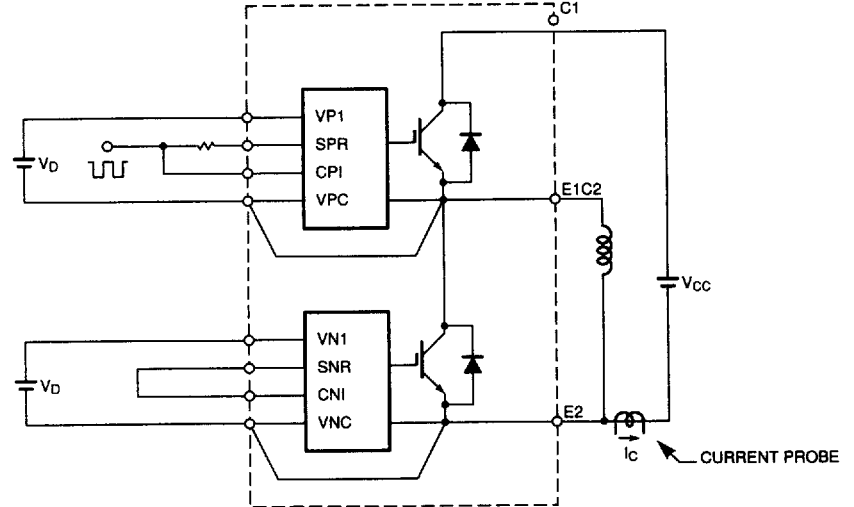

Figure 3 Switching Test

Powerex, Inc., Hillis Street, Youngwood, Pennsylvania 15697 (412) 925-7272

Powerex, Europe, S.A. 428 Avenue G. Durand, BP107, 72003 Le Mans, France (43) 41.14.14

PM200DHA120

Intellmod-3 Modules

Single Phase IGBT Inverter Output

200 Amperes/460 Volt Line

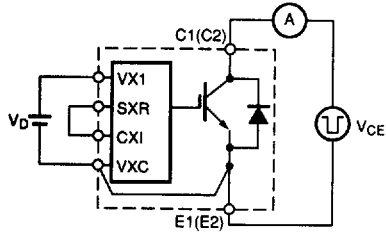

Figure 4 I_{CES} Test

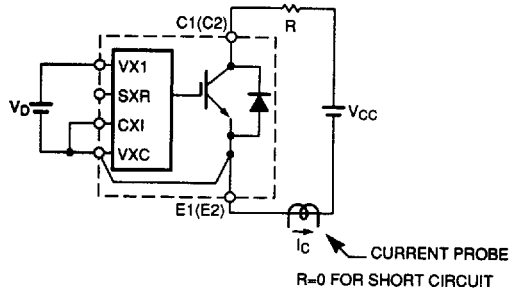

Figure 5 Over Current and Short Circuit Test