

### Chopper IGBTMOD™ E-Series Module 200 Amperes/600 Volts

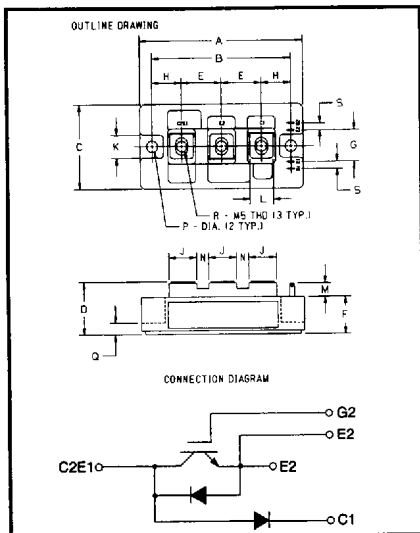

**CM200E3Y-12E**  
Outline Drawing

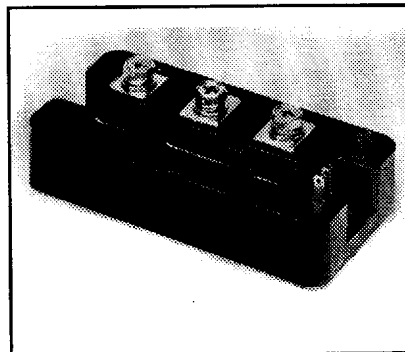

**CM200E3Y-12E**  
Chopper IGBTMOD™ E-Series Module  
200 Amperes/600 Volts

#### Description:

Powerex Chopper IGBTMOD™ Modules are designed for use in switching applications. Each module consists of one IGBT Transistor having a reverse-connected super-fast recovery free-wheel diode and an anode-collector connected super-fast recovery free-wheel diode. All components and interconnects are isolated from the heat sinking baseplate, offering simplified system assembly and thermal management.

#### Features:

- Low Drive Power
- Low  $V_{CE(sat)}$
- Discrete Super-Fast Recovery (150ns) Free-Wheel Diode
- High Frequency Operation (15-20kHz)
- Isolated Baseplate for Easy Heat Sinking

#### Applications:

- DC Motor Control
- Boost Regulator

#### Ordering Information:

Example: Select the complete part module number you desire from the table below

-i.e. CM200E3Y-12E is a 600V ( $V_{CES}$ ), 200 Ampere Chopper IGBTMOD™ Power Module.

Type	Current Rating Amperes	$V_{CES}$ Volts (x 50)
CM	200	12

Dimensions	Inches	Millimeters
A	3.70	94.0
B	3.150±0.01	80.0±0.25
C	1.89	48.0
D	1.18 Max.	30.0 Max.
E	0.90	23.0
F	0.83	21.2
G	0.71	18.0
H	0.67	17.0
J	0.63	16.0
K	0.51	13.0
L	0.47	12.0
M	0.30	7.5
N	0.28	7.0
P	0.256 Dia.	Dia. 6.5
Q	0.26	6.5
R	M5 Metric	M5
S	0.16	4.0

**CM200E3Y-12E**  
**Chopper IGBTMOD™ E-Series Module**  
 200 Amperes/600 Volts

**Absolute Maximum Ratings,  $T_J = 25\text{ }^\circ\text{C}$  unless otherwise specified**

Ratings	Symbol	CM200E3Y-12E	Units
Junction Temperature	$T_J$	-40 to 150	$^\circ\text{C}$
Storage Temperature	$T_{stg}$	-40 to 125	$^\circ\text{C}$
Collector-Emitter Voltage (G-E SHORT)	$V_{CES}$	600	Volts
Gate-Emitter Voltage	$V_{GES}$	$\pm 20$	Volts
Collector Current	$I_C$	200	Amperes
Peak Collector Current	$I_{CM}$	400*	Amperes
Diode Forward Current	$I_{FM}$	200	Amperes
Diode Forward Surge Current	$I_{FM}$	400*	Amperes
Power Dissipation	$P_d$	780	Watts
Max. Mounting Torque M5 Terminal Screws	-	17	in-lb
Max. Mounting Torque M6 Mounting Screws	-	26	in-lb
Module Weight (Typical)	-	270	Grams
V Isolation	$V_{RMS}$	2500	Volts

\* Pulse width and repetition rate should be such that device junction temperature does not exceed the device rating.

**Static Electrical Characteristics,  $T_J = 25\text{ }^\circ\text{C}$  unless otherwise specified**

Characteristics	Symbol	Test Conditions	Min.	Typ.	Max.	Units
Collector-Cutoff Current	$I_{CES}$	$V_{CE} = V_{CES}, V_{GE} = 0V$	-	-	1.0	mA
Gate Leakage Current	$I_{GES}$	$V_{GE} = V_{GES}, V_{CE} = 0V$	-	-	0.5	$\mu\text{A}$
Gate-Emitter Threshold Voltage	$V_{GE(th)}$	$I_C = 20\text{mA}, V_{CE} = 10V$	3.5	5.0	6.5	Volts
Collector-Emitter Saturation Voltage	$V_{CE(sat)}$	$I_C = 200A, V_{GE} = 15V$	-	2.7	3.5**	Volts
Total Gate Charge	$Q_G$	$I_C = 200A, V_{GE} = 15V, T_J = 150^\circ\text{C}$	-	2.7	-	Volts
Diode Forward Voltage	$V_{FM}$	$V_{CC} = 300V, I_C = 200A, V_{GS} = 15V$	-	1000	-	nC
		$I_E = 200A, V_{GS} = 0V$	-	-	2.5	Volts

\*\* Pulse width and repetition rate should be such that device junction temperature rise is negligible.

**Dynamic Electrical Characteristics,  $T_J = 25\text{ }^\circ\text{C}$  unless otherwise specified**

Characteristics	Symbol	Test Conditions	Min.	Typ.	Max.	Units
Input Capacitance	$C_{ies}$	$V_{GE} = 0V, V_{CE} = 10V, f = 1\text{MHz}$	-	-	40	nF
Output Capacitance	$C_{oes}$		-	-	12	nF
Reverse Transfer Capacitance	$C_{res}$		-	-	8	nF
Resistive	Turn-on Delay Time	$V_{CC} = 300V, I_C = 200A,$ $V_{GE1} = V_{GE2} = 15V, R_G = 3.1\Omega$	-	-	400	ns
	Rise Time		-	-	700	ns
Switch Times	Turn-off Delay Time		-	-	700	ns
	Fall Time		-	-	350	ns
Diode Reverse Recovery Time	$t_{rr}$		$I_E = 200A, di_E/dt = -400A/\mu\text{s}$	-	-	200
Diode Reverse Recovery Charge	$Q_{rr}$	$I_E = 200A, di_E/dt = -400A/\mu\text{s}$	-	2.6	-	$\mu\text{C}$

**Thermal and Mechanical Characteristics,  $T_J = 25\text{ }^\circ\text{C}$  unless otherwise specified**

Characteristics	Symbol	Test Conditions	Min.	Typ.	Max.	Units
Thermal Resistance, Junction to Case	$R_{th(j-c)}$	Per IGBT	-	-	0.16	$^\circ\text{C/W}$
Thermal Resistance, Junction to Case	$R_{th(j-c)}$	Per Free Wheel Diode	-	-	0.35	$^\circ\text{C/W}$
Contact Thermal Resistance	$R_{th(c-f)}$	Per Half Module	-	-	0.13	$^\circ\text{C/W}$

**CM200E3Y-12E**  
**Chopper IGBTMOD™ E-Series Module**  
 200 Amperes/600 Volts

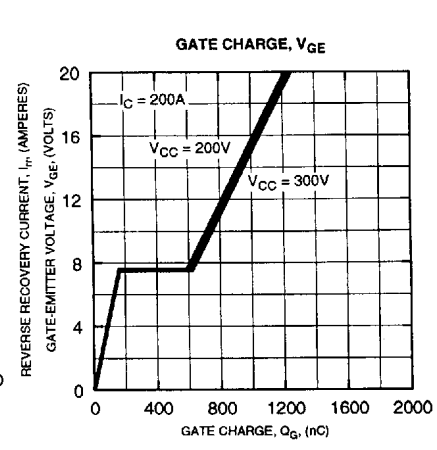
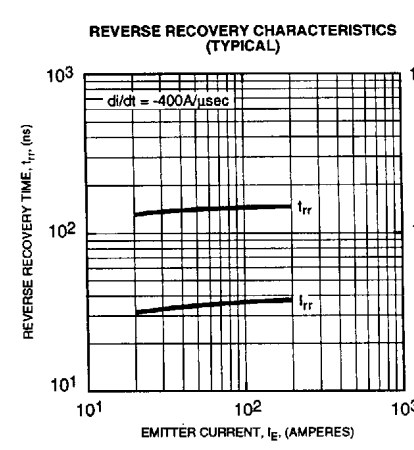
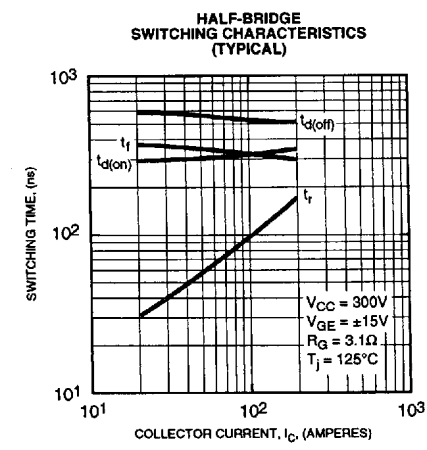
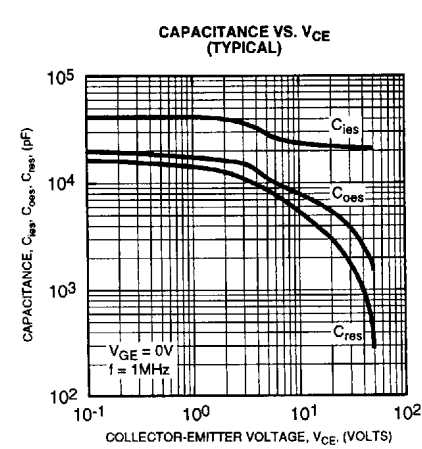
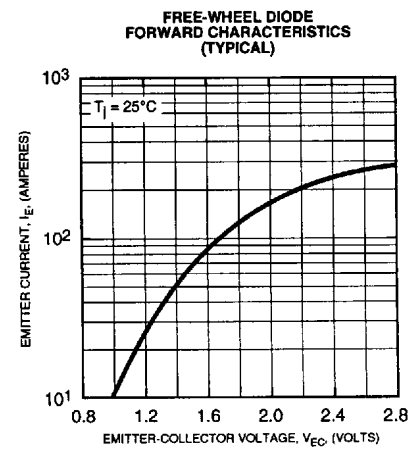
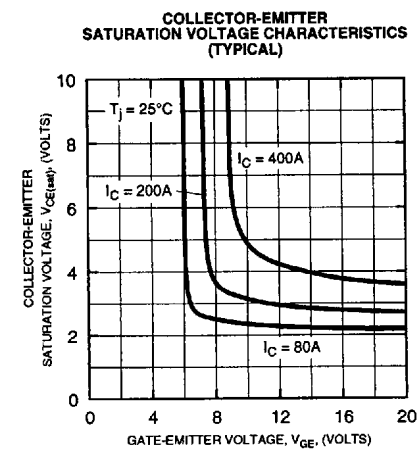
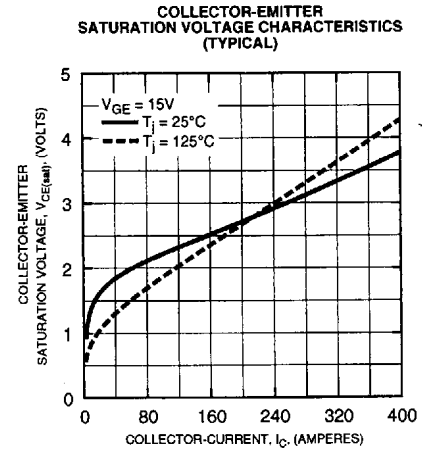
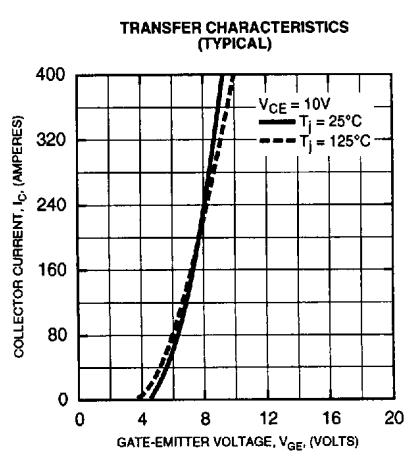
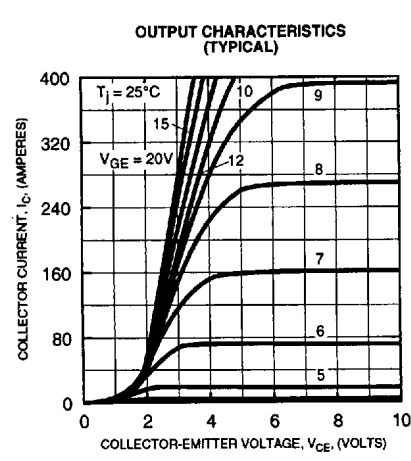

**CM200E3Y-12E**  
**Chopper IGBTMOD™ E-Series Module**  
 200 Amperes/600 Volts

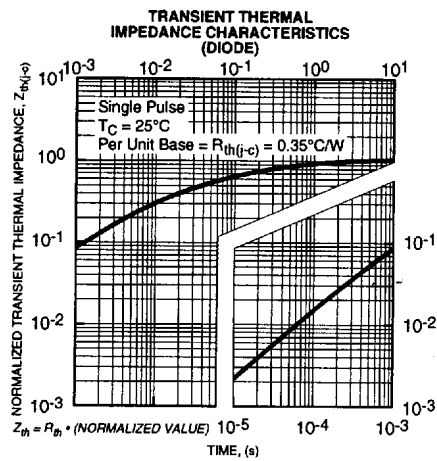
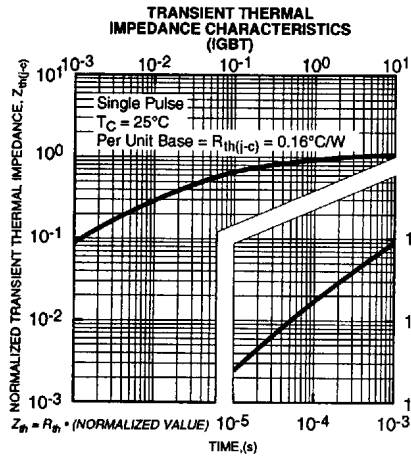

## SWITCHING TIME TEST CIRCUITS & WAVEFORMS

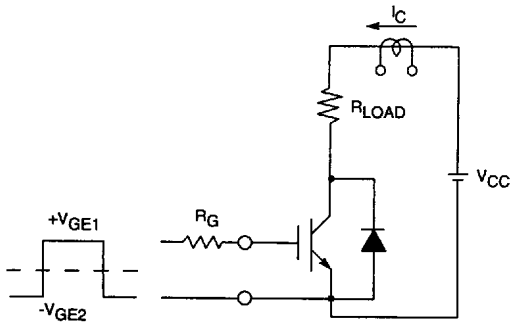

RESISTANCE LOAD SWITCHING TEST CIRCUIT

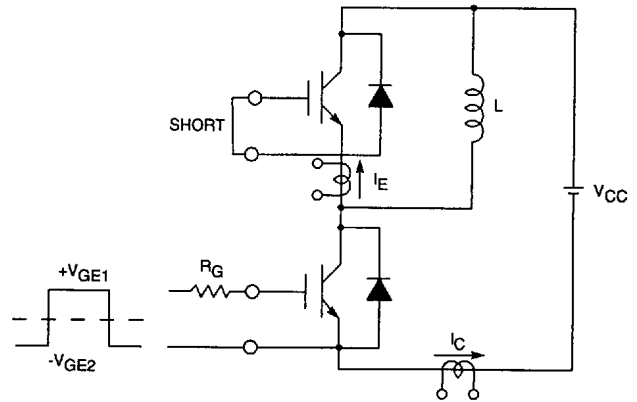

HALF-BRIDGE SWITCHING TEST CIRCUIT

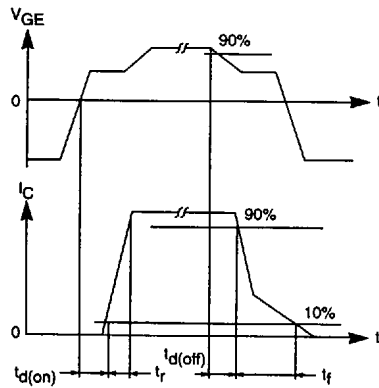

SWITCHING TIME TEST WAVEFORMS

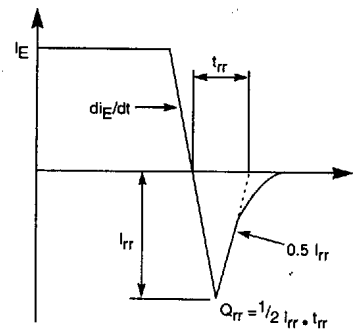

$t_{rr}, Q_{rr}$  WAVEFORMS