

High Power Chip Type White LED NCCW022E

Technical Reference

Characteristics

- High Power Chip Type LEDs with Lens
- Half Angle(2θ1/2) : 80°
- Surface Mount Chip LEDs

Applications

- General Lighting
- Automotive Applications
- LCD Back Lights
- Illuminations
- Indicators

Directivity

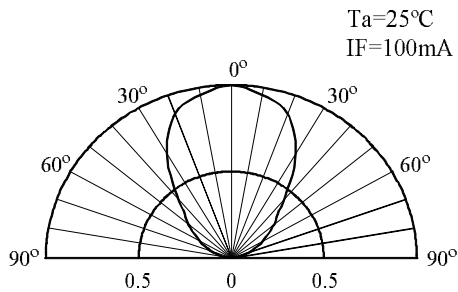

Absolute Maximum Ratings

(Tc=25°C)

Item	Symbol	Absolute Maximum Rating	Unit
Forward Current	IF	500	mA
Pulse Forward Current ※	IFP	1,000	mA
Allowable Reverse Current	IR	85	mA
Power Dissipation	PD	2.1	W
Operating Temperature	Topr	-30~+85	°C
Storage Temperature	Tstg	-40~+100	°C

※ Pulse width Max.10ms Duty ratio Max.1/10

Electrical · Optical Characteristics

(Tc=25°C)

Item	Symbol	Condition	Min.	Typ.	Max.	Unit
DC Forward Voltage	VF	IF=350mA	-	3.8	(4.2)	V
Luminous Flux	Y	IF=350mA	-	23	-	lm
Chromaticity Coordinate ※	x	IF=350mA	-	0.31	-	-
Chromaticity Coordinate ※	y	IF=350mA	-	0.32	-	-

※ Please refer to CIE 1931 Chromaticity diagram.

Outline Dimension

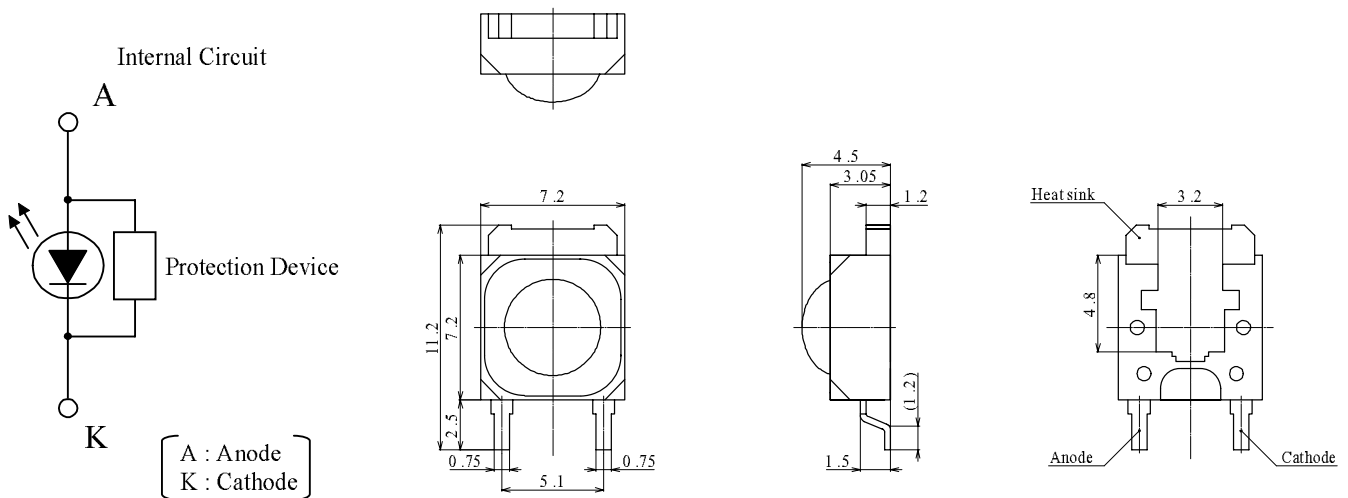
 Tolerance : ± 0.2
 Unit : mm

- The formal specifications must be exchanged and signed by both parties before large volume purchase begins.
- The appearance and specifications of the product may be modified for improvement without notice.

NICHIA CORPORATION

 □Headquarters
 491 Oka Kaminaka-Cho Anan-Shi TOKUSHIMA 774-8601,JAPAN
 Phone : (0884)22-2311 Telefax : (0884)21-0148

 LA-KSE2077A
 <Cat.No.021218>

 □Tokyo Office
 13F Tamachi Center Building
 34-7 Shiba 5-Chome Minato-Ku TOKYO 108-0014,JAPAN
 Phone : (03)3456-3746 Telefax : (03)5440-7516

 □Osaka Office
 10F Nissei-Shin-Osaka Building
 4-30 Miyahara 3-Chome Yodogawa-Ku OSAKA 532-0003,JAPAN
 Phone : (06)6396-7708 Telefax : (06)6396-7399

CAUTIONS

White LEDs are devices which are materialized by combining Blue LEDs and special phosphors. Consequently, the color of White LEDs is changed a little by operating current. Care should be taken when using LEDs.

(1) Be sure to go through baking before you do reflow soldering (hand soldering).

Baking conditions : more than 24 hours at $65 \pm 5^\circ\text{C}$ or more than 6 hours at $80 \pm 5^\circ\text{C}$

(2) Soldering Conditions

- The LEDs can be soldered in place using the reflow soldering method.
- Recommended soldering conditions.

Reflow Soldering		Hand Soldering (lead part)	
Pre-heat	120~150°C	Temperature	300°C Max.
Pre-heat time	120 seconds Max.	Soldering time	3seconds Max.
Peak temperature	240°C Max		(Only once)
Soldering time	10 seconds Max.		
Condition	refer to Temperature-profile		

※ After reflow soldering, rapid cooling should be avoided.

[Temperature-profile (Surface of circuit board)]

Use the following conditions shown in the figure.

[Recommended soldering pad design]

Use the following conditions shown in the figure.

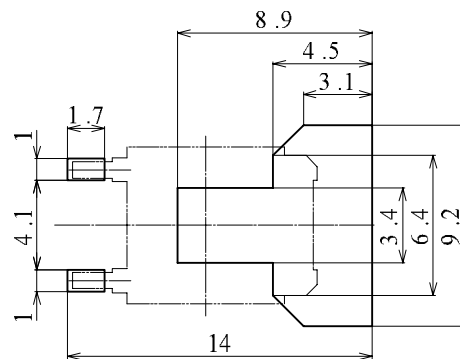
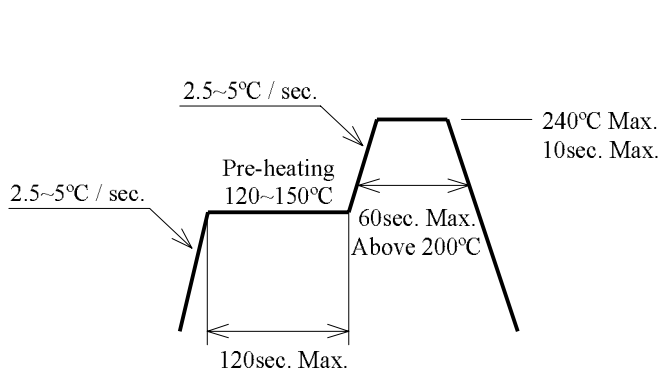

(Unit : mm)

- Basically, modification should not be done after the LEDs have been soldered. If modification cannot be avoided, a hotplate should be used with confirmation that the characteristics of the LEDs will not be damaged by the modification after soldering.
- Reflow soldering should not be done more than once.
- Solder the Heat sink part to mount, if it can not be done, use a good adhesive to get the heat conduction.
- When soldering, do not stress the LEDs during heating.
- After soldering, do not bend the circuit board.

(3) Static Electricity

- Static electricity or surge voltage might damage LEDs. It is recommended that a wrist band or an anti-electrostatic glove will be used when handling the LEDs.
- All devices, equipments and machinery must be properly grounded. It is recommended to take measures against surge voltage for the equipments that mount the LEDs.
- When inspecting the final products in which LEDs were assembled, it is recommended to check whether the assembled LEDs are damaged by static electricity or not. It is easy to find static-damaged LEDs by a light-on test or a VF test at a lower current (below 1mA is recommended).
- Damaged LEDs will show some unusual characteristics such as the forward voltage becomes lower, or the LEDs do not light at the low current. Criteria : ($V_F > 2.0\text{V}$ at $I_F = 0.5\text{mA}$)

(4) Heat Generation

- Thermal design of the end product is of paramount importance. Please consider the heat generation of the LEDs when making the system design. The coefficient of temperature increase per input electric power is affected by the thermal resistance of the circuit board and density of LED placement on the board, as well as other components. It is necessary to avoid intense heat generation and to operate within the maximum ratings given in this specification.
- The operating current should be decided after considering the maximum ambient temperature of LEDs.

(5) Others

- Nichia LED electrodes are comprised of silver plated copper alloy. The silver surface may be affected by environments which contain corrosive gases and so on. Please avoid conditions which may cause the LEDs to be corroded, tarnish or discolor. This corrosion or discoloration may cause difficulty during soldering operations. It is recommended that the LEDs will be used soon after opening the plastic bag.
- The LEDs light output is strong enough to injure human eyes. Precautions must be taken to prevent staring directly the LEDs with unaided eyes for more than a few seconds.
- The LEDs described in this brochure are intended to be used for ordinary electronic equipment (such as office equipment, communications equipment, measurement instruments and household appliances). Inform Nichia's sales staff in advance if the application is required exceptional quality and reliability, particularly when the failure or malfunction of the LEDs may directly jeopardize life or health (such as for airplanes, aerospace, submersible repeaters, nuclear reactor control systems, automobiles, traffic control equipment, life support systems and safety devices)
- User shall not act a reverse engineering by disassembling or analysis of the LEDs without having prior written consent by Nichia When defective LEDs are found, the User shall inform Nichia directly before disassembling or analysis.