

Technical Data Sheet

0805 Package Chip LED

Preliminary

17-21-R7C-A0N1P2B0C-3T-AM



Feature

- RoHS compliant.
- Chip LED package.
- White diffused resin.
- Wide viewing angle 130°.
- Brightness: 28.00 to 71 mcd at 10 mA.
- Qualification according to AEC-Q101.
- Precondition: Bases on JEDEC J-STD 020 Level 3.
- Useable in severe lead free processes with automotive reflow profile (IR reflow or wave soldering))

This is a preliminary specification intended for design purposes and subject to change without prior notice.

Applications

- Automotive backlighting or indicator: Dashboard, switch, audio and video equipments...etc.
- Backlight: LCD, switches, symbol, mobile phone and illuminated advertising.
- Display for indoor and outdoor application.
- Ideal for coupling into light guides.
- Substitution of traditional light.
- Optical indicator.
- General applications.

Device Selection Guide

Chip	Emitted Color	Resin Color
Material		
AlGaInP	Dark-Red	Water Clear

Technical Data Sheet

0805 Package Chip LED

Preliminary

17-21-R7C-A0N1P2B0C-3T-AM

Absolute Maximum Ratings (Ta=25°C)

Parameter	Symbol	Rating	Unit
Reverse Voltage	V_R	10	V
Forward Current	I_F	25	mA
Peak Forward Current (Duty 1/10 @1KHz)	I_{FP}	60	mA
Power Dissipation	P_d	60	mW
Junction Temperature	T_j	115	°C
Operating Temperature	T_{opr}	-40 ~ +100	°C
Storage Temperature	T_{stg}	-40 ~ +110	°C
Thermal resistance	$R_{th\ J-A}$	800	K/W
	$R_{th\ J-S}$	450	K/W
Soldering Temperature	T_{sol}	Reflow Soldering : 260 °C for 30 sec. Hand Soldering : 350 °C for 3 sec.	
ESD (Classification acc. AEC Q101)	ESD_{HBM}	2000	V
	ESD_{MM}	200	V

Technical Data Sheet

0805 Package Chip LED

Preliminary

17-21-R7C-A0N1P2B0C-3T-AM

Electro-Optical Characteristics (Ta=25°C)

Parameter	Symbol	Min.	Typ.	Max.	Unit	Condition
Luminous Intensity	I_v	28.00	-----	71	mcd	$I_F=10mA$
Viewing Angle	$2\theta_{1/2}$	-----	130	-----	deg	$I_F=10mA$
Peak Wavelength	λ_p	-----	639	-----	nm	$I_F=10mA$
Dominant Wavelength	λ_d	625.5	----	637.5	nm	$I_F=10mA$
Spectrum Radiation Bandwidth	$\Delta\lambda$	-----	20	-----	nm	$I_F=10mA$
Forward Voltage	V_F	1.75	----	2.35	V	$I_F=10mA$
Reverse Current	I_R	-----	-----	10	μA	$V_R=10V$
Temperature coefficient of λ_p	TC_{λ_p}	-----	0.13	-----	nm/K	$I_F=10mA$
Temperature coefficient of λ_d	TC_{λ_d}	-----	0.08	-----	nm/K	$I_F=10mA$
Temperature coefficient of V_F	TC_V	-----	-4.3	-----	mV/K	$I_F=10mA$

Note:

Tolerance of Luminous Intensity: $\pm 11\%$

Tolerance of Dominant Wavelength: $\pm 1nm$

Tolerance of Forward Voltage: $\pm 0.1V$

Technical Data Sheet

0805 Package Chip LED

Preliminary

17-21-R7C-A0N1P2B0C-3T-AM

Bin Range of Luminous Intensity

Bin Code	Min.	Max.	Unit	Condition
N1	28.00	35.50	mcd	I _F =10mA
N2	35.50	45.00		
P1	45.	56		
P2	56	71		

Note

Tolerance of Luminous Intensity : ±11%

Bin Range of Dominant Wavelength

Bin Code	Min.	Max.	Unit	Condition
E6	625.5	629.5	nm	I _F =10mA
E7	629.5	633.5		
E8	633.5	637.5		

Note:

Tolerance of Dominant Wavelength: ±1nm

Technical Data Sheet

0805 Package Chip LED

Preliminary

17-21-R7C-A0N1P2B0C-3T-AM

Typical Electro-Optical Characteristics Curves

Typical curve of spectral distribution:

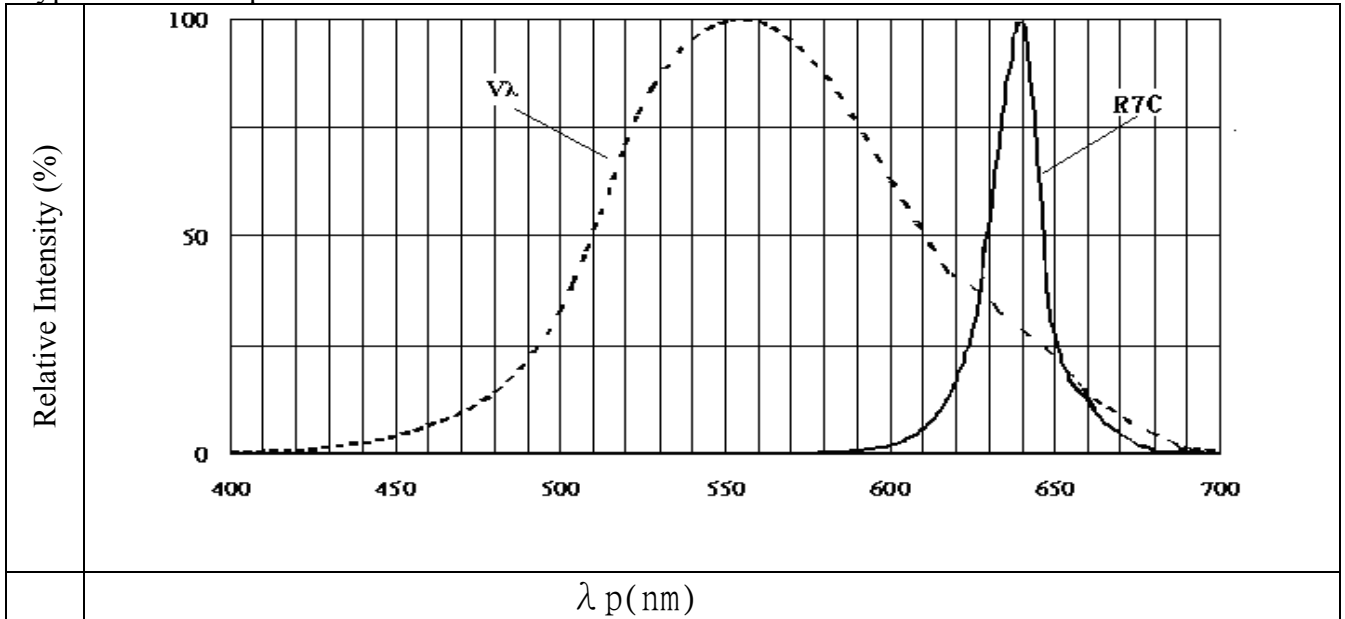

Note: $V(\lambda)$ =Standard eye response curve

Diagram characteristics of radiation

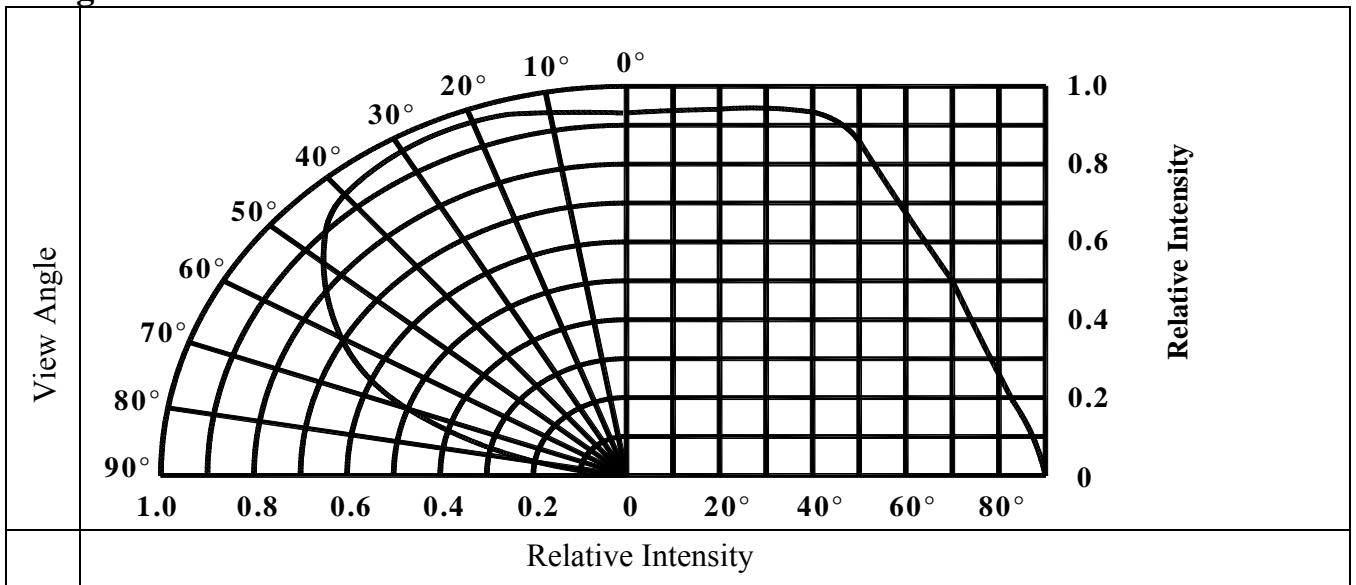

Technical Data Sheet

0805 Package Chip LED

Preliminary

17-21-R7C-A0N1P2B0C-3T-AM

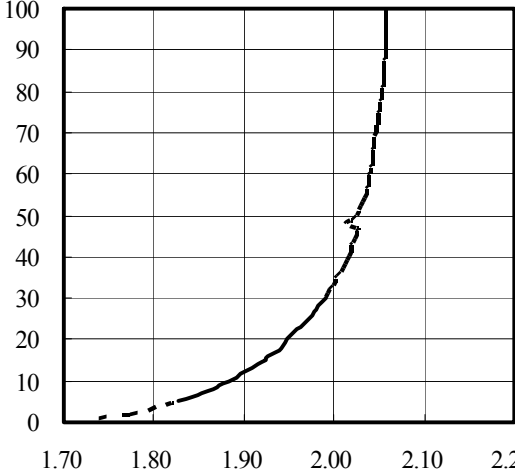
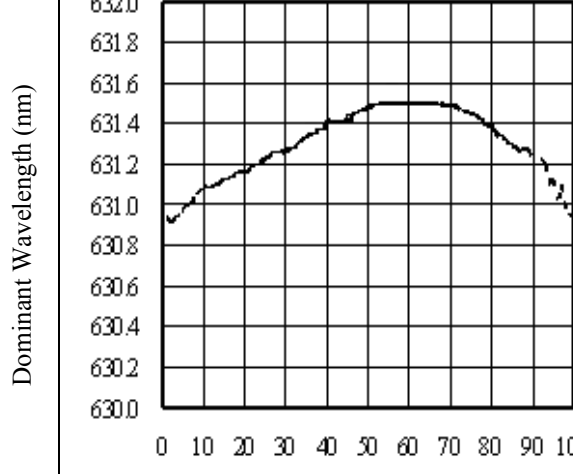
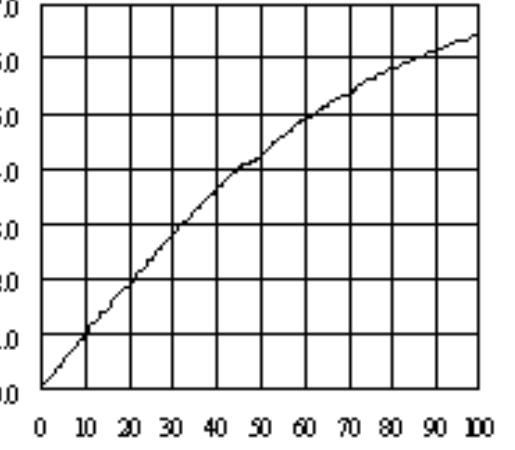
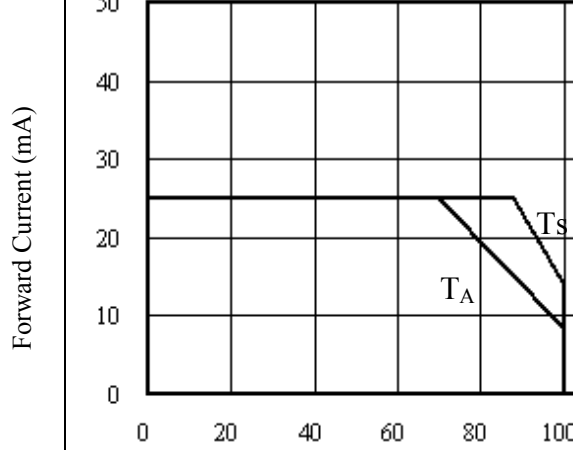
Forward Current vs. Forward Voltage (Ta=25°C)		Dominant Wavelength vs. Forward Current (Ta=25°C)	
Forward Current (mA)		Dominant Wavelength (nm)	
	Forward Voltage (V)		Forward Current (mA)
Relative Luminous Intensity vs. Forward Current (Ta=25°C)		Max. Permissible Forwarded Current (Ta=25°C)	
Relative Luminous Intensity		Forward Current (mA)	
	Forward Current (mA)		Temperature (°C)

Technical Data Sheet

0805 Package Chip LED

Preliminary

17-21-R7C-A0N1P2B0C-3T-AM

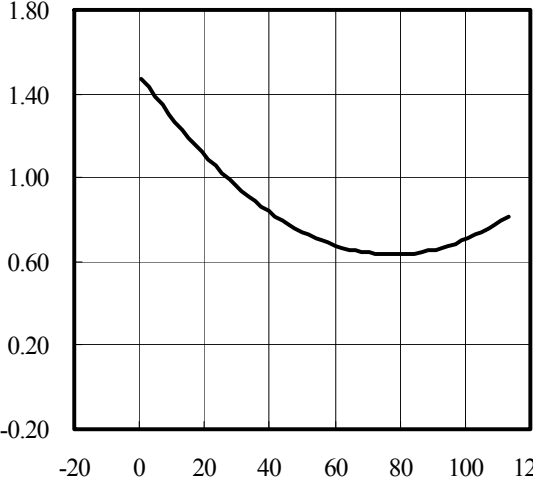
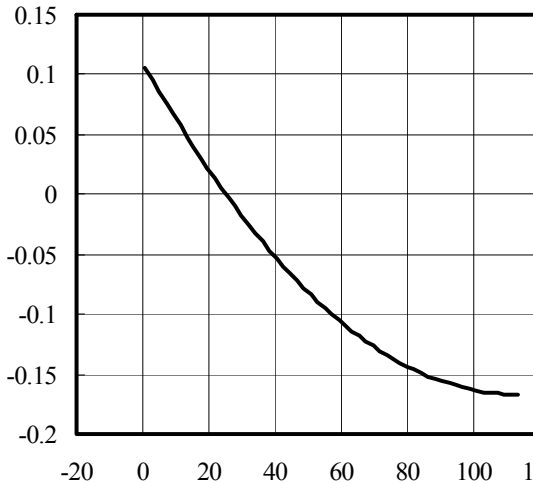
Relative Luminous Intensity vs. Junction Temperature		Relative Forward Voltage vs. Junction Temperature	
Relative Luminous Intensity		Relative Luminous Intensity	
	Junction Temperature (°C)		Junction Temperature (°C)
Note: $f(T_j) = I_v / I_v(25^\circ\text{C})$; $I_F = 10\text{mA}$		Note: $\Delta V_F = V_F - V_F(25^\circ\text{C}) = f(T_j)$; $I_F = 10\text{mA}$	

Technical Data Sheet

0805 Package Chip LED

Preliminary

17-21-R7C-A0N1P2B0C-3T-AM

Package Dimension

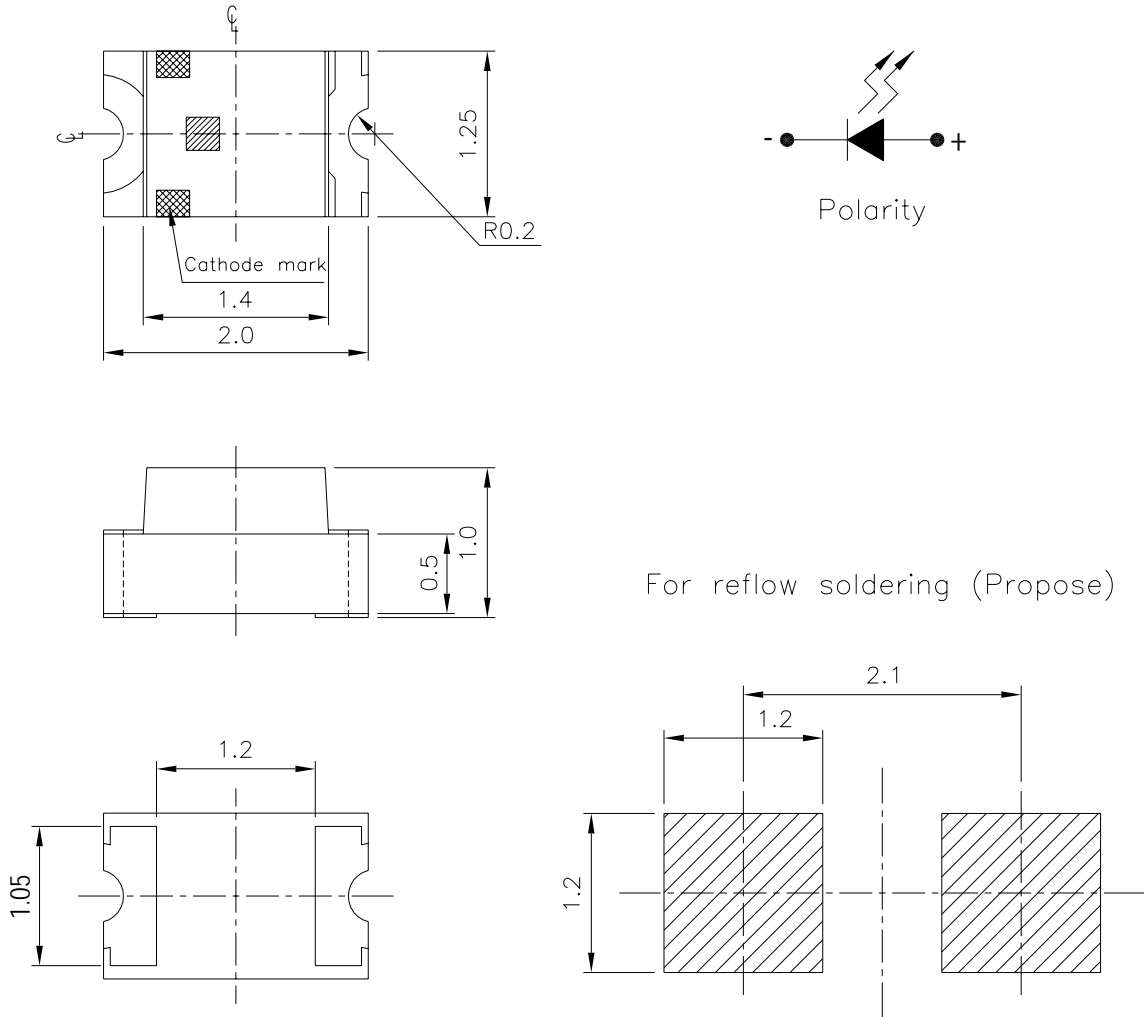

Note: Tolerances unless mentioned ± 0.1 mm. Unit = mm

Technical Data Sheet

0805 Package Chip LED

Preliminary

17-21-R7C-A0N1P2B0C-3T-AM

Label Explanation

- **CPN:** Customer's Product Number
- **P/N:** Product Number
- **QTY:** Packing Quantity
- **CAT:** Luminous Intensity Rank
- **HUE:** Dom. Wavelength Rank
- **REF:** Forward Voltage Rank
- **LOT No:** Lot Numbe



Reel Dimensions

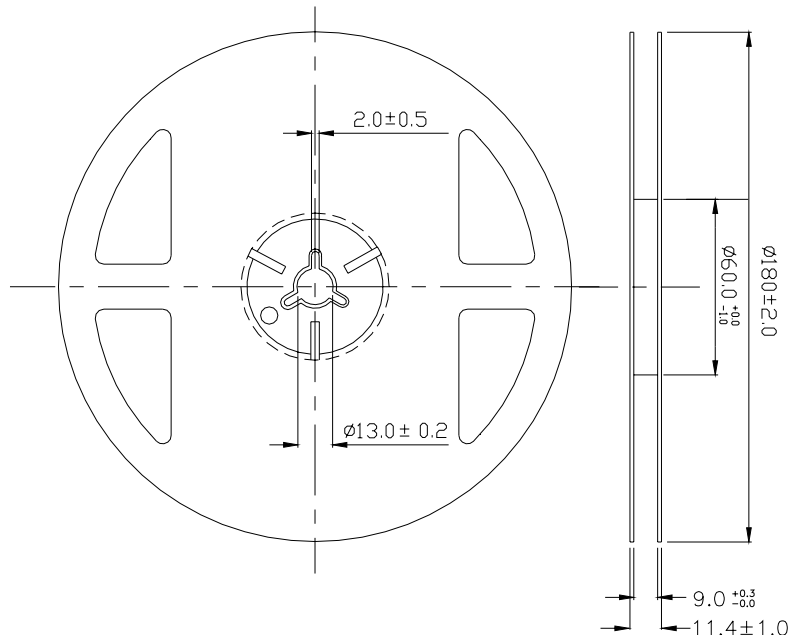

Note: Unit = mm

Technical Data Sheet

0805 Package Chip LED

Preliminary

17-21-R7C-A0N1P2B0C-3T-AM

Carrier Tape Dimensions: Loaded Quantity 3000 pcs Per Reel

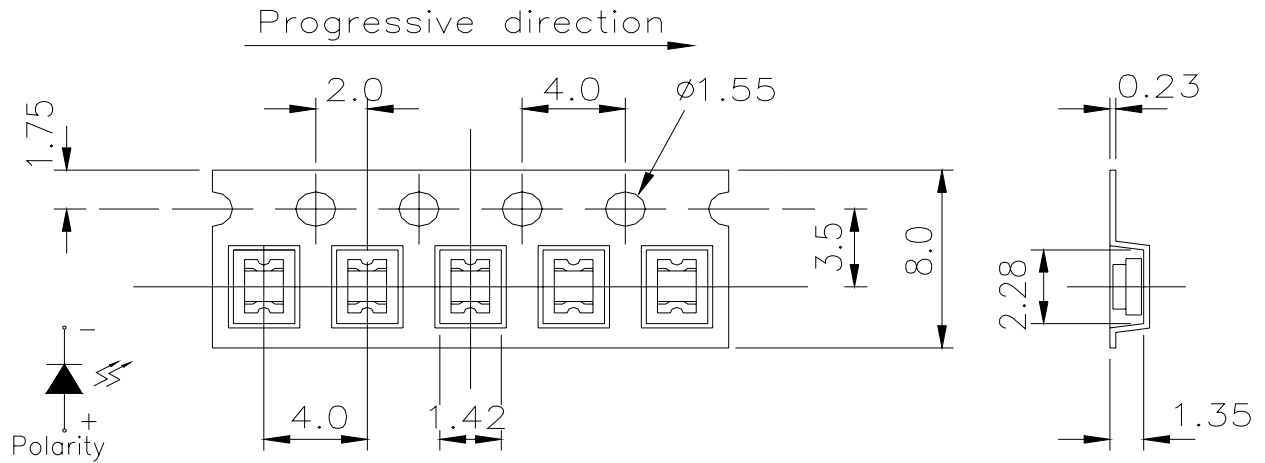

Note: Tolerances unless mentioned ± 0.1 mm. Unit = mm

Moisture Resistant Packaging Process and Materials

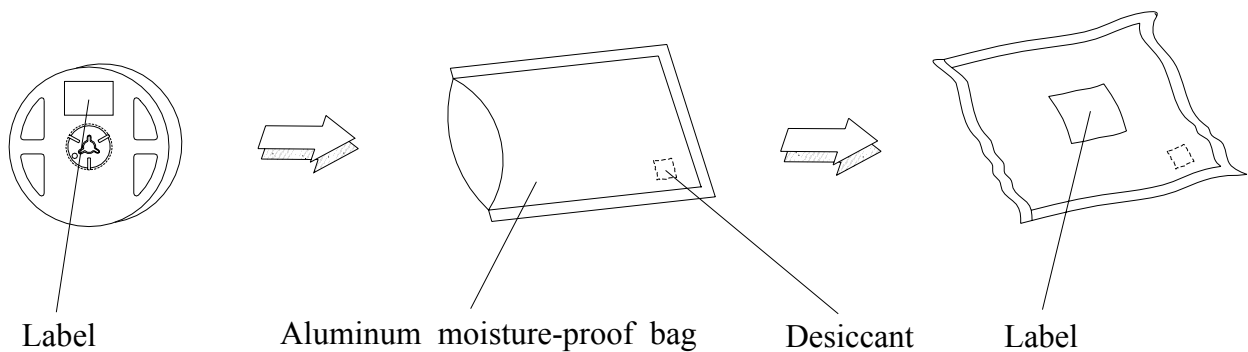

Technical Data Sheet

0805 Package Chip LED

Preliminary

17-21-R7C-A0N1P2B0C-3T-AM

Precautions for Use

1. Soldering Condition

1.1 (A) Maximum Body Case Temperature Profile for evaluation of Reflow Profile

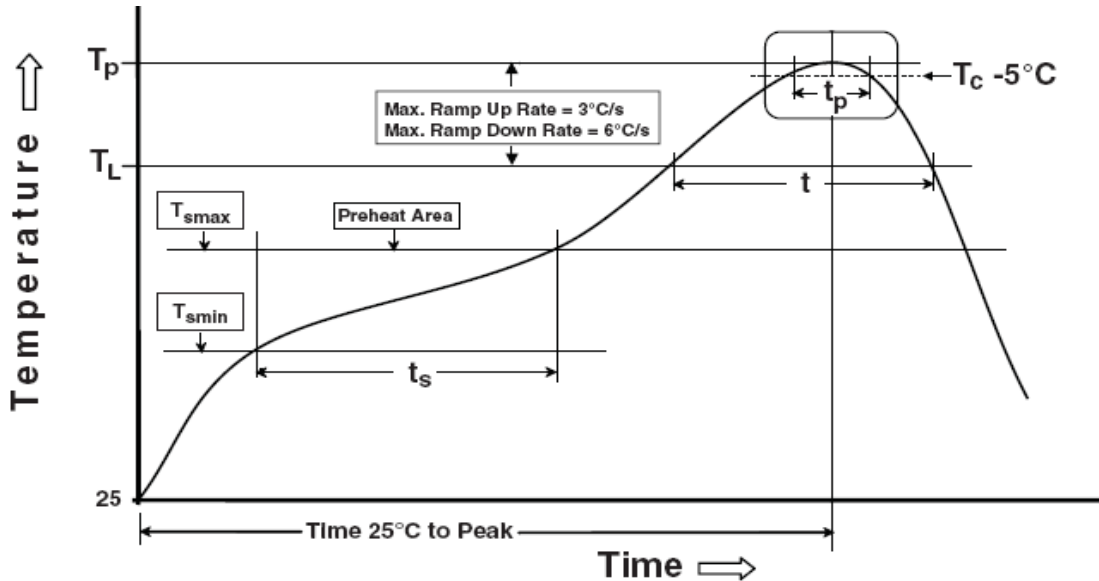

Note:

Preheat

Temperature min (T_{smin})

Temperature max (T_{smax})

Time (T_{smin} to T_{smax}) (t_s)

Average ramp-up rate (T_{smax} to T_p)

Other

Liquidus Temperature (T_L)

Time above Liquidus Temperature (t_L)

Peak Temperature (T_p)

Time within 5°C of Actual Peak Temperature: $T_p - 5^\circ\text{C}$

Ramp- Down Rate from Peak Temperature

Time 25°C to peak temperature

Reflow times

Reference: IPC/JEDEC J-STD-020D

150 °C

200°C

60-120 seconds

3 °C/second max.

217 °C

60-150 sec

260°C

30 s

6°C /second max.

8 minutes max.

3 times

All parameters are maximum body case temperature values and cannot be considered as a soldering profile. The body case temperature was measured by soldering a thermal couple to the soldering point of LEDs.

Technical Data Sheet

0805 Package Chip LED

Preliminary

17-21-R7C-A0N1P2B0C-3T-AM

(B) Recommend soldering pad

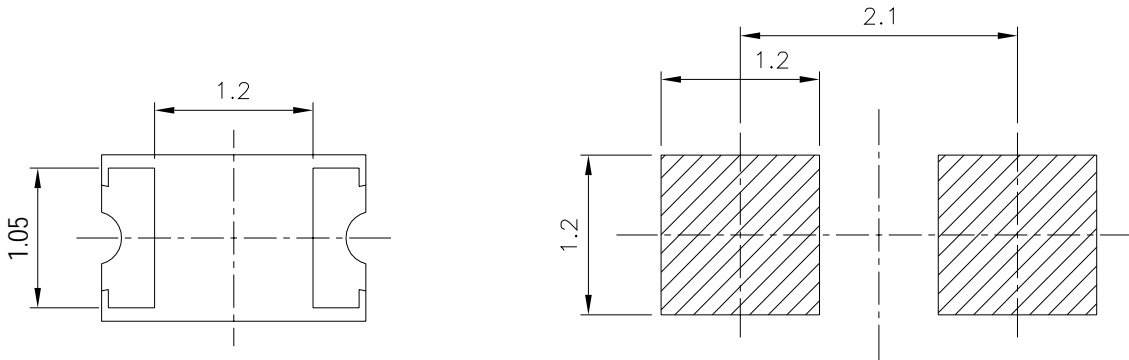

Note: Tolerances unless mentioned ± 0.1 mm. Unit = mm

2. Current limiting

A resistor should be used to limit current spikes that can be caused by voltage fluctuations. Otherwise damage could occur.

3. Storage

3.1 Moisture proof bag should only be opened immediately prior to usage.

3.2 Environment should be less than 30°C and 60% RH when moisture proof bag is opened.

3.3 After opening the package MSL Conditions stated on page 1 of this spec should not be exceeded.

3.4 If the moisture sensitivity card indicates higher than acceptable moisture, the component should be baked at min. $60^{\circ}\text{deg} \pm 5^{\circ}\text{deg}$ for 24 hours.

4. Iron Soldering

Hand soldering is not recommended for regular production. These guidelines are for rework only. Soldering iron tip should contact each terminal no more than 3 sec at 350°C , using soldering iron with nominal power less than 25W. Allow min. 2 sec. between soldering intervals.

5. Usage

Do not exceed the values given in this specification.

Application Restrictions

1. High reliability applications such as military/aerospace, automotive safety/security systems, and medical equipment may require different product. If you have any concerns, please contact Everlight before using this product in your application. This specification guarantees the quality and performance of the product as an individual component. Do not use this product beyond the specification described in this document.