

Programmable logic sequencer (16 × 45 × 12)

PLS155

DESCRIPTION

The PLS155 is a 3-State output, registered logic element combining AND/OR gate arrays with clocked J-K flip-flops. These J-K flip-flops are dynamically convertible to D-type via a "fold-back" inverting buffer and control gate F_C . It features 4 registered I/O outputs (F) in conjunction with 8 bidirectional I/O lines (B). These yield variable I/O gate and register configurations via control gates (D, L) ranging from 16 inputs to 12 outputs.

The AND/OR arrays consist of 32 logic AND gates, 13 control AND gates, and 21 OR gates with fusible link connections for programming I/O polarity and direction. All AND gates are linked to 4 inputs (I), bidirectional I/O lines (B), internal flip-flop outputs (Q), and Complement Array output (\bar{C}). The Complement Array consists of a NOR gate optionally linked to all AND gates for generating and propagating complementary AND terms.

On-chip T/C buffers couple either True (I, B, Q) or Complement (\bar{I} , \bar{B} , \bar{Q} , \bar{C}) input polarities to all AND gates, whose outputs can be optionally linked to all OR gates. Any of the 32 AND gates can drive bidirectional I/O lines (B), whose output polarity is individually programmable through a set of Ex-OR gates for implementing AND-OR or AND-NOR logic functions. Similarly, any of the AND gates can drive the J-K inputs of all flip-flops. The Asynchronous Preset and Reset lines (P, R), are driven from the OR matrix.

All flip-flops are positive edge-triggered and can be used as input, output or I/O (for interfacing with a bidirectional data bus) in conjunction with load control gates (L), steering inputs (I), (B), (Q) and programmable output select lines (E).

The PLS155 is field programmable, enabling the user to quickly generate custom patterns using standard programming equipment.

Order codes are listed below.

FEATURES

- $f_{MAX} = 14\text{MHz}$
– 18.2MHz clock rate
- Field-Programmable (Ni-Cr link)
- 4 dedicated inputs
- 13 control gates
- 32 AND gates
- 21 OR gates
- 45 product terms:
– 32 logic terms
– 13 control terms
- 8 bidirectional I/O lines
- 4 bidirectional registers
- J-K, T, or D-type flip-flops
- Asynchronous Preset/Reset
- Complement Array
- Active-High or -Low outputs
- Programmable $\bar{O}E$ control
- Positive edge-triggered clock
- Input loading: $-100\mu\text{A}$ (max.)
- Power dissipation: 750mW (typ.)
- TTL compatible
- 3-State outputs

APPLICATIONS

- Random sequential logic
- Synchronous up/down counters
- Shift registers
- Bidirectional data buffers
- Timing function generators
- System controllers/synchronizers
- Priority encoder/registers

PIN CONFIGURATIONS

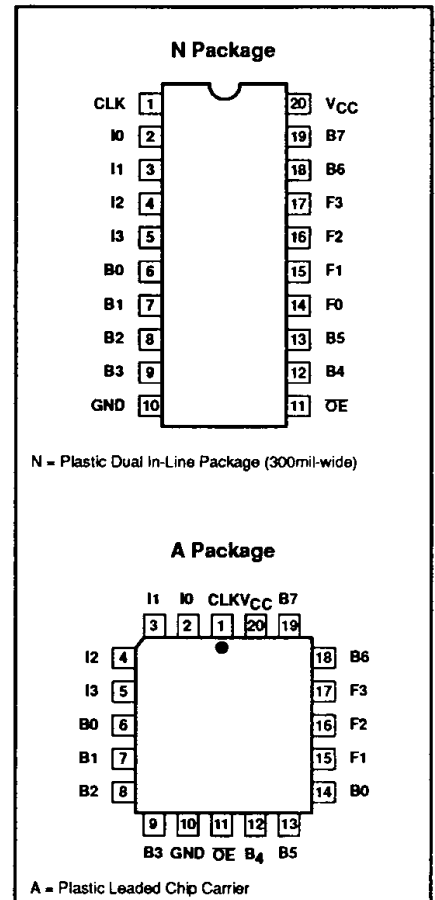

ORDERING INFORMATION

DESCRIPTION	ORDER CODE	DRAWING NUMBER
20-Pin Plastic Dual In-Line Package (300mil-wide)	PLS155N	0408D
20-Pin Plastic Leaded Chip Carrier	PLS155A	0400E

Programmable logic sequencer (16 × 45 × 12)

PLS155

LOGIC DIAGRAM

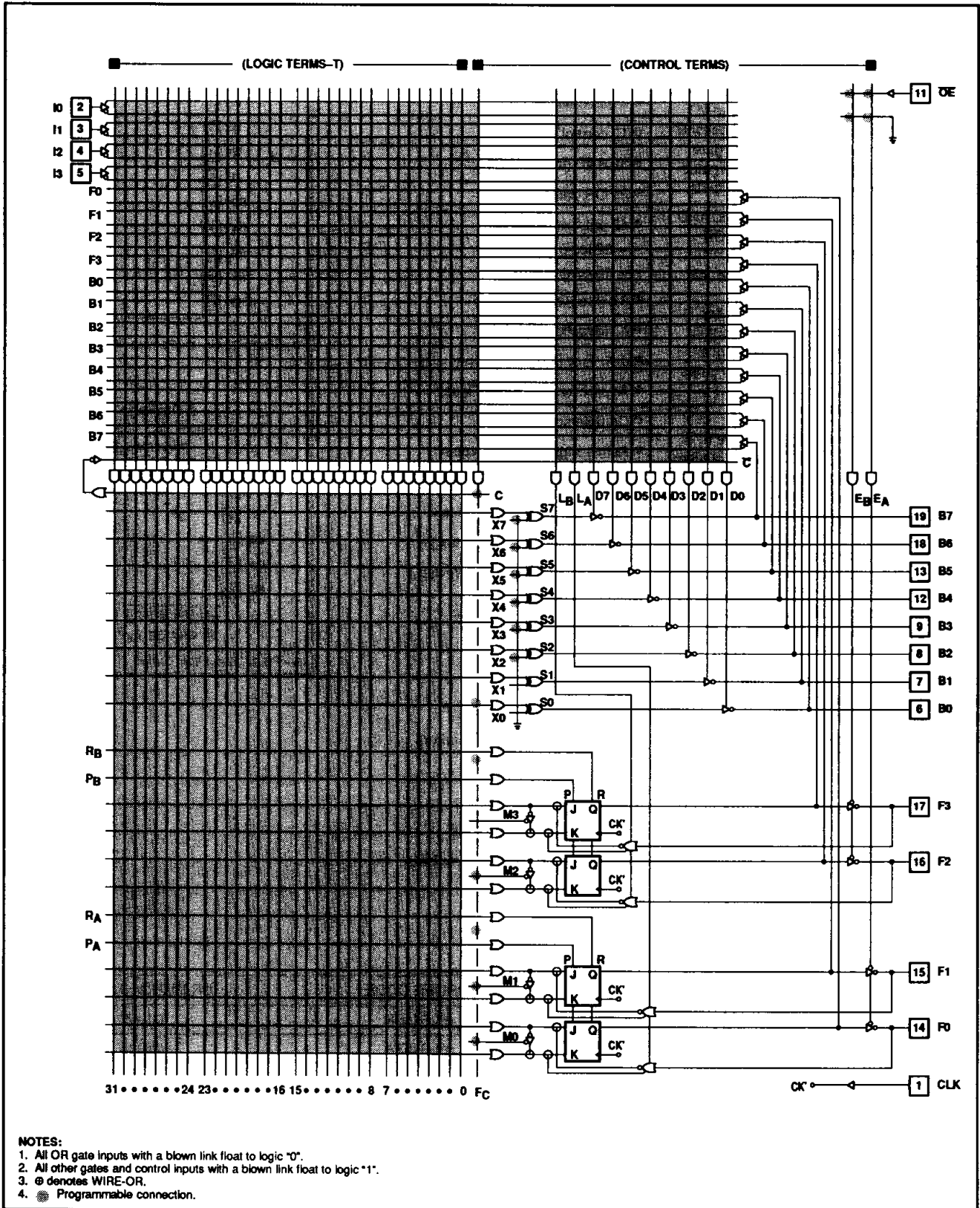

Programmable logic sequencer (16 × 45 × 12)

PLS155

FUNCTIONAL DIAGRAM

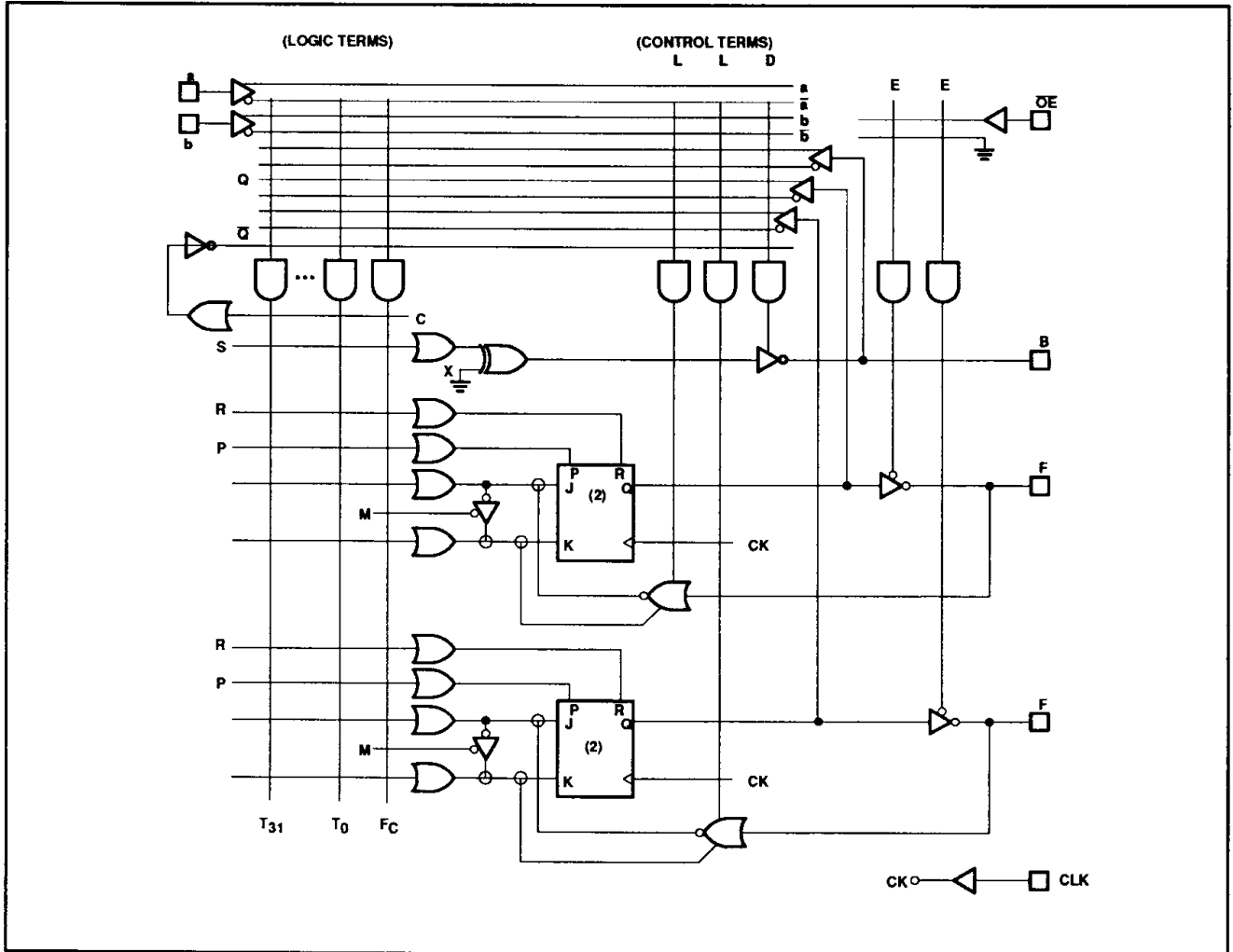

FLIP-FLOP TRUTH TABLE

OE	L	CK	P	R	J	K	Q	F
H								Hi-Z
L	X	X	H	L	X	X	H	L
L	X	X	L	H	X	X	L	H
L	L	↑	L	L	L	L	Q	Q̄
L	L	↑	L	L	L	H	L	H
L	L	↑	L	L	H	L	H	L
L	L	↑	L	L	H	H	Q̄	Q
H	H	↑	L	L	L	H	L	H*
H	H	↑	L	L	H	L	H	L*
+10V	X	↑	X	X	L	H	L	H**
	X	↑	X	X	H	L	H	L**

NOTES:

- Positive Logic:
 $J-K = T_0 + T_1 + T_2 \dots T_{31}$
 $T_n = C \cdot (I_0 \cdot I_1 \cdot I_2 \dots) \cdot (Q_0 \cdot Q_1 \dots) \cdot (B_0 \cdot B_1 \dots)$
- ↑ denotes transition from Low to High level.
- X = Don't care
- * = Forced at F_n pin for loading the J-K flip-flop in the Input mode. The load control term, L_n must be enabled (HIGH) and the p-terms that are connected to the associated flip-flop must be forced LOW (disabled) during Preload.
- At P = R = H, Q = H. The final state of Q depends on which is released first.
- ** = Forced at F_n pin to load J-K flip-flop independent of program code (Diagnostic mode), 3-State B outputs.

Programmable logic sequencer

(16 × 45 × 12)

PLS155

LOGIC FUNCTION

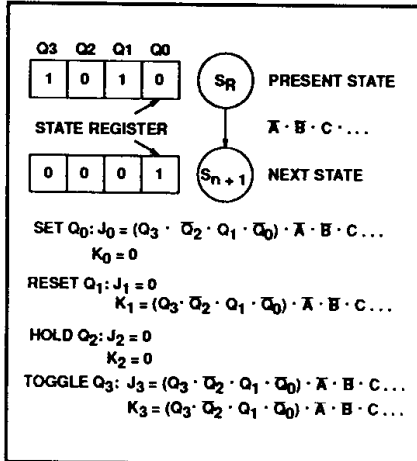

NOTE:

Similar logic functions are applicable for D and T mode flip-flops.

VIRGIN STATE

The factory shipped virgin device contains all fusible links intact, such that:

1. OE is always enabled.
2. Preset and Reset are always disabled.
3. All transition terms are disabled.
4. All flip-flops are in D-mode unless otherwise programmed to J-K only or J-K or D (controlled).
5. All B pins are inputs and all F pins are outputs unless otherwise programmed.

THERMAL RATINGS

TEMPERATURE	
Maximum junction	150°C
Maximum ambient	75°C
Allowable thermal rise ambient to junction	75°C

ABSOLUTE MAXIMUM RATINGS¹

SYMBOL	PARAMETER	RATINGS		UNIT
		Min	Max	
V _{CC}	Supply voltage		+7	V _{DC}
V _{IN}	Input voltage		+5.5	V _{DC}
V _{OUT}	Output voltage		+5.5	V _{DC}
I _{IN}	Input currents	-30	+30	mA
I _{OUT}	Output currents		+100	mA
T _{amb}	Operating temperature range	0	+75	°C
T _{stg}	Storage temperature range	-65	+150	°C

NOTES:

1. Stresses above those listed may cause malfunction or permanent damage to the device. This is a stress rating only. Functional operation at these or any other condition above those indicated in the operational and programming specification of the device is not implied.

Programmable logic sequencer

(16 × 45 × 12)

PLS155

DC ELECTRICAL CHARACTERISTICS0°C ≤ T_{amb} ≤ +75°C, 4.75V ≤ V_{CC} ≤ 5.25V

SYMBOL	PARAMETER	TEST CONDITION	LIMITS			UNIT
			MIN	TYP ¹	MAX	
Input voltage²						
V _{IH}	High	V _{CC} = MAX	2.0			V
V _{IL}	Low	V _{CC} = MIN			0.8	V
V _{IC}	Clamp	V _{CC} = MIN, I _{IN} = -12mA		-0.8	-1.2	V
Output voltage²						
V _{OH}	High	V _{CC} = MIN I _{OH} = -2mA	2.4			V
V _{OL}	Low	I _{OL} = 10mA		0.35	0.5	V
Input current⁵						
I _{IH}	High	V _{CC} = MAX V _{IN} = 5.5V		<1	80	μA
I _{IL}	Low	V _{IN} = 0.45V		-10	-100	μA
Output current						
I _{O(OFF)}	Hi-Z state ^{5, 6}	V _{CC} = MAX V _{OUT} = 5.5V		1	80	μA
I _{OS}	Short circuit ^{3, 7}	V _{OUT} = 0.45V V _{OUT} = 0V		-1	-140	μA
I _{CC}	V _{CC} supply current ⁴	V _{CC} = MAX	-15		-70	mA
Capacitance						
C _{IN}	Input	V _{CC} = 5.0V V _{IN} = 2.0V		8		pF
C _{OUT}	Output	V _{OUT} = 2.0V		15		pF

NOTES:

- All typical values are at V_{CC} = 5V, T_{amb} = +25°C.
- All voltage values are with respect to network ground terminal.
- Test one at a time.
- I_{CC} is measured with the \overline{OE} input grounded, all other inputs at 4.5V and the outputs open.
- Leakage values are a combination of input and output leakage.
- Measured with V_{IH} applied to \overline{OE} .
- Duration of short circuit should not exceed 1 second.

Programmable logic sequencer (16 × 45 × 12)

PLS155

AC ELECTRICAL CHARACTERISTICS

 $0^{\circ}\text{C} \leq T_{\text{amb}} \leq +75^{\circ}\text{C}$, $4.75\text{V} \leq V_{\text{CC}} \leq 5.25\text{V}$, $R_1 = 470\Omega$, $R_2 = 1\text{k}\Omega$

SYMBOL	PARAMETER	FROM	TO	TEST CONDITION	LIMITS			UNIT
					MIN	TYP ¹	MAX	
Pulse width								
t_{CKH}	Clock ² High	CK +	CK -	$C_L = 30\text{pF}$	25	20		ns
t_{CKL}	Clock Low	CK -	CK +	$C_L = 30\text{pF}$	30	20		ns
t_{CKP}	Period	CK +	CK +	$C_L = 30\text{pF}$	70	50		ns
t_{PRH}	Preset/Reset pulse	(I,B) -	(I,B) +	$C_L = 30\text{pF}$	40	30		ns
Setup time⁵								
t_{IS1}	Input	(I,B) \pm	CK +	$C_L = 30\text{pF}$	40	30		ns
t_{IS2}	Input (through F_n)	F \pm	CK +	$C_L = 30\text{pF}$	20	10		ns
t_{IS3}	Input (through Complement Array) ⁴	(I,B) \pm	CK +	$C_L = 30\text{pF}$	65	40		ns
Hold time								
t_{IH1}	Input	(I,P) \pm	CK +	$C_L = 30\text{pF}$	0	-10		ns
t_{IH2}	Input	F \pm	CK +	$C_L = 30\text{pF}$	15	10		ns
Propagation delays								
t_{CKO}	Clock	CK +	F \pm	$C_L = 30\text{pF}$		25	30	ns
t_{OE1}	Output enable ³	$\overline{\text{OE}}$ -	F -	$C_L = 30\text{pF}$		20	30	ns
t_{OD1}	Output disable ³	$\overline{\text{OE}}$ +	F +	$C_L = 5\text{pF}$		20	30	ns
t_{PD}	Output	(I,B) \pm	B \pm	$C_L = 30\text{pF}$		40	50	ns
t_{OE2}	Output enable ³	(I,B) +	B \pm	$C_L = 30\text{pF}$		35	55	ns
t_{OD2}	Output disable ³	(I,B) -	B +	$C_L = 5\text{pF}$		30	35	ns
t_{PRO}	Preset/Reset	(I,B) +	F \pm	$C_L = 30\text{pF}$		50	55	ns

NOTES:

- All typical values are at $V_{\text{CC}} = 5\text{V}$, $T_{\text{amb}} = +25^{\circ}\text{C}$.
- To prevent spurious clocking, clock rise time (10% - 90%) $\leq 10\text{ns}$.
- For 3-State output; output enable times are tested with $C_L = 30\text{pF}$ to the 1.5V level, and S_1 is open for high-impedance to High tests and closed for high-impedance to Low tests. Output disable times are tested with $C_L = 5\text{pF}$. High-to-High impedance tests are made to an output voltage of $V_T = (V_{\text{OH}} - 0.5\text{V})$ with S_1 open, and Low-to-High impedance tests are made to the $V_T = (V_{\text{OL}} + 0.5\text{V})$ level with S_1 closed.
- When using the Complement Array $t_{\text{CKP}} = 95\text{ns}$ (min).
- Limits are guaranteed with 12 product terms maximum connected to each sum term line.
- For test circuits, waveforms and timing diagrams see the following pages.

VOLTAGE WAVEFORMS

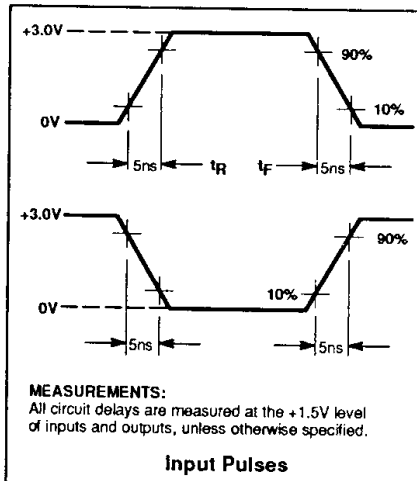

TEST LOAD CIRCUIT

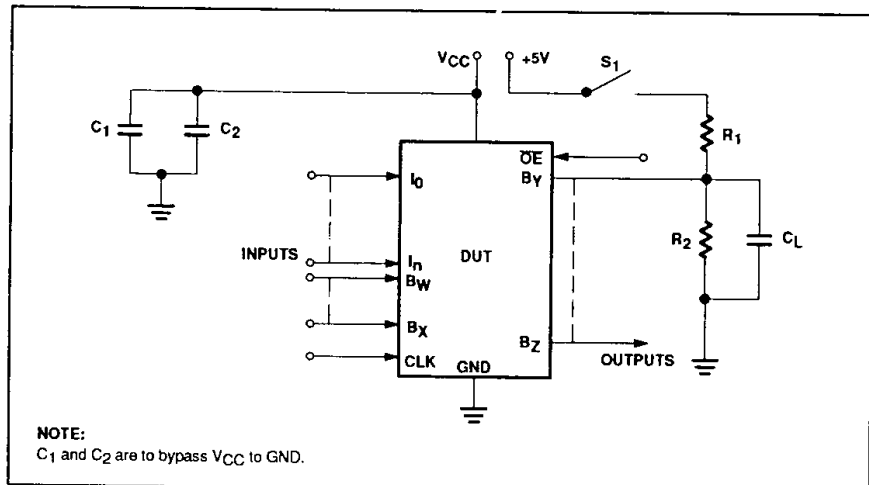

Programmable logic sequencer (16 × 45 × 12)

PLS155

TIMING DIAGRAMS

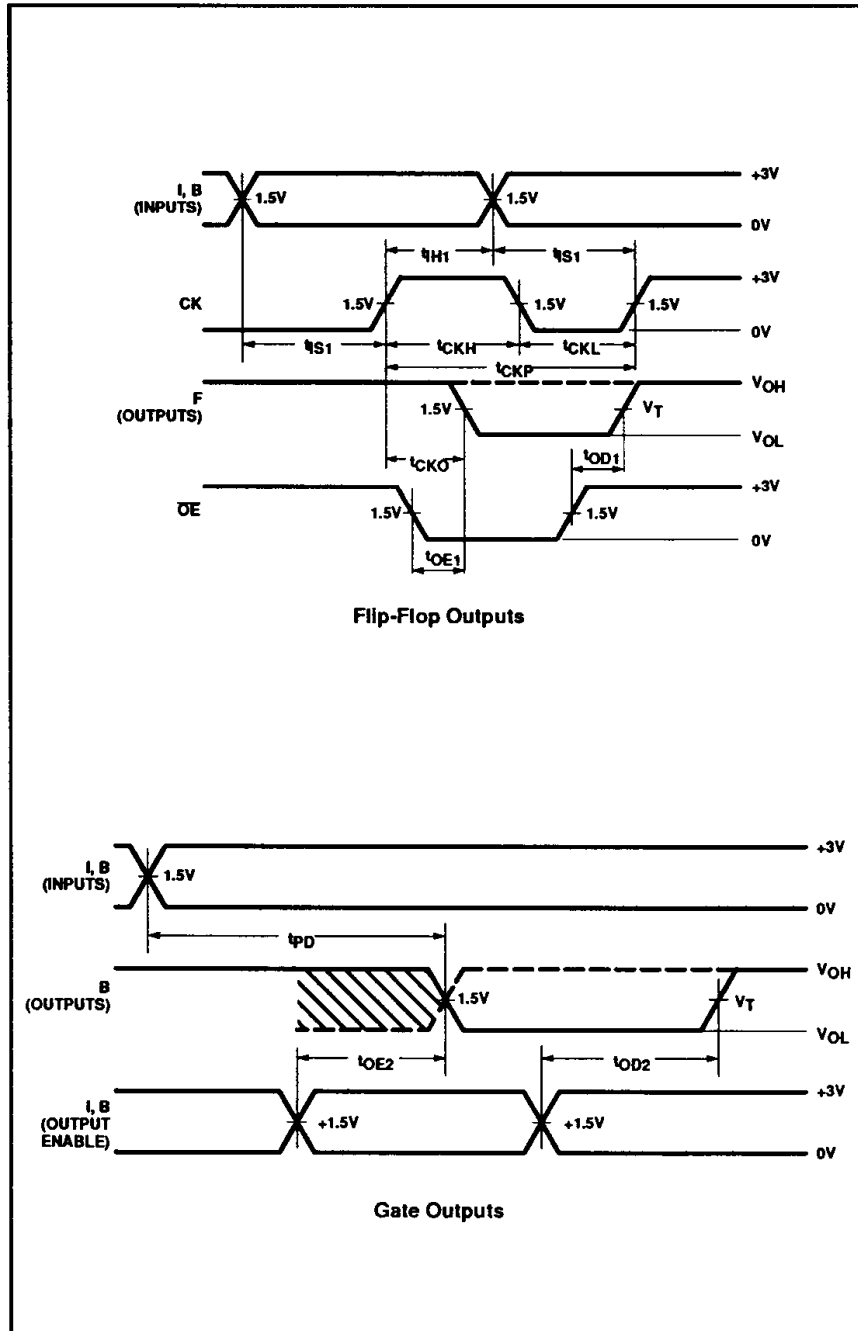

TIMING DEFINITIONS

SYMBOL	PARAMETER
t_{CKH}	Width of input clock pulse.
t_{CKL}	Interval between clock pulses.
t_{CKP}	Clock period.
t_{PRH}	Width of preset input pulse.
t_{S1}	Required delay between beginning of valid input and positive transition of clock.
t_{S2}	Required delay between beginning of valid input forced at flip-flop output pins, and positive transition of clock.
t_{IH1}	Required delay between positive transition of clock and end of valid input data.
t_{IH2}	Required delay between positive transition of clock and end of valid input data forced at flip-flop output pins.
t_{CKO}	Delay between positive transition of clock and when outputs become valid (with OE Low).
t_{OE1}	Delay between beginning of Output Enable Low and when outputs become valid.
t_{OD1}	Delay between beginning of Output Enable High and when outputs are in the OFF-State.
t_{PD}	Propagation delay between combinational inputs and outputs.
t_{OE2}	Delay between predefined Output Enable High, and when combinational outputs become valid.
t_{OD2}	Delay between predefined Output Enable Low and when combinational outputs are in the OFF-State.
t_{PRO}	Delay between positive transition of predefined Preset/Reset input, and when flip-flop outputs become valid.

Programmable logic sequencer
(16 × 45 × 12)

PLS155

TIMING DIAGRAMS (Continued)

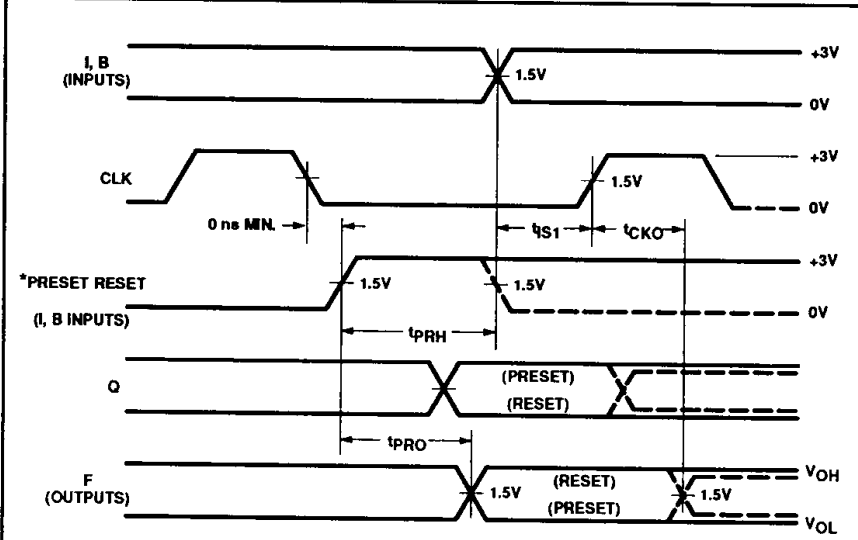

Asynchronous Preset/Reset

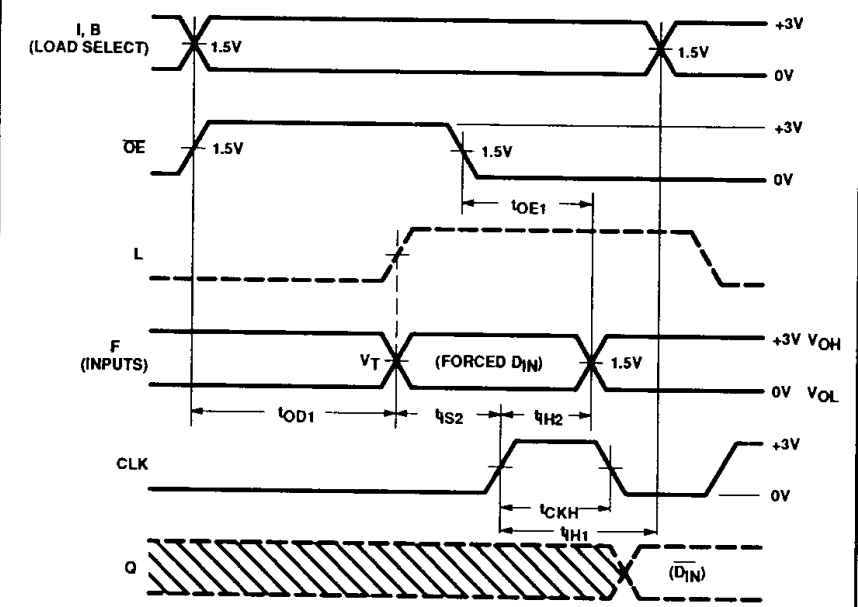

Flip-Flop Input Mode

Programmable logic sequencer (16 × 45 × 12)

PLS155

LOGIC PROGRAMMING

The PLS155 is fully supported by industry standard (JEDEC compatible) PLD CAD tools, including Philips' Semiconductors SNAP, Data I/O Corporation's ABEL™ and Logical Devices Inc.'s CUPL™ design software packages.

All packages allow Boolean and state equation entry formats. SNAP, ABEL and CUPL also accept, as input, schematic capture format.

PLS155 logic designs can also be generated using the program table entry format detailed on the following pages. This program table entry format is supported by the Philips Semiconductors SNAP PLD design software package only.

To implement the desired logic functions, the state of each logic variable from logic equations (I, B, O, P, etc.) is assigned a symbol. The symbols for TRUE,

COMPLEMENT, INACTIVE, PRESET, etc., are defined below.

PROGRAMMING AND SOFTWARE SUPPORT

Refer to Section 9 (*Development Software*) and Section 10 (*Third-party Programmer/ Software Support*) of this data handbook for additional information.

"AND" ARRAY – (I), (B), (Qp)

<p>(T, Fc, L, P, R, D)_n</p> <table border="1"> <thead> <tr> <th>STATE</th> <th>CODE</th> </tr> </thead> <tbody> <tr> <td>INACTIVE^{1,2}</td> <td>0</td> </tr> </tbody> </table>	STATE	CODE	INACTIVE ^{1,2}	0	<p>(T, Fc, L, P, R, D)_n</p> <table border="1"> <thead> <tr> <th>STATE</th> <th>CODE</th> </tr> </thead> <tbody> <tr> <td>I, B, Q</td> <td>H</td> </tr> </tbody> </table>	STATE	CODE	I, B, Q	H	<p>(T, Fc, L, P, R, D)_n</p> <table border="1"> <thead> <tr> <th>STATE</th> <th>CODE</th> </tr> </thead> <tbody> <tr> <td>$\bar{I}, \bar{B}, \bar{Q}$</td> <td>L</td> </tr> </tbody> </table>	STATE	CODE	$\bar{I}, \bar{B}, \bar{Q}$	L	<p>(T, Fc, L, P, R, D)_n</p> <table border="1"> <thead> <tr> <th>STATE</th> <th>CODE</th> </tr> </thead> <tbody> <tr> <td>DONT CARE</td> <td>-</td> </tr> </tbody> </table>	STATE	CODE	DONT CARE	-
STATE	CODE																		
INACTIVE ^{1,2}	0																		
STATE	CODE																		
I, B, Q	H																		
STATE	CODE																		
$\bar{I}, \bar{B}, \bar{Q}$	L																		
STATE	CODE																		
DONT CARE	-																		

"COMPLEMENT" ARRAY – (C)

<p>(T_n, Fc)</p> <table border="1"> <thead> <tr> <th>ACTION</th> <th>CODE</th> </tr> </thead> <tbody> <tr> <td>INACTIVE^{1,3,5}</td> <td>0</td> </tr> </tbody> </table>	ACTION	CODE	INACTIVE ^{1,3,5}	0	<p>(T_n, Fc)</p> <table border="1"> <thead> <tr> <th>ACTION</th> <th>CODE</th> </tr> </thead> <tbody> <tr> <td>GENERATE⁵</td> <td>A</td> </tr> </tbody> </table>	ACTION	CODE	GENERATE ⁵	A	<p>(T_n, Fc)</p> <table border="1"> <thead> <tr> <th>ACTION</th> <th>CODE</th> </tr> </thead> <tbody> <tr> <td>PROPAGATE</td> <td>•</td> </tr> </tbody> </table>	ACTION	CODE	PROPAGATE	•	<p>(T_n, Fc)</p> <table border="1"> <thead> <tr> <th>ACTION</th> <th>CODE</th> </tr> </thead> <tbody> <tr> <td>TRANSPARENT</td> <td>-</td> </tr> </tbody> </table>	ACTION	CODE	TRANSPARENT	-
ACTION	CODE																		
INACTIVE ^{1,3,5}	0																		
ACTION	CODE																		
GENERATE ⁵	A																		
ACTION	CODE																		
PROPAGATE	•																		
ACTION	CODE																		
TRANSPARENT	-																		

"OR" ARRAY – (F-F CONTROL MODE)

<table border="1"> <thead> <tr> <th>ACTION</th> <th>CODE</th> </tr> </thead> <tbody> <tr> <td>J-K OR D (CONTROLLED)</td> <td>A</td> </tr> </tbody> </table>	ACTION	CODE	J-K OR D (CONTROLLED)	A	<table border="1"> <thead> <tr> <th>ACTION</th> <th>CODE</th> </tr> </thead> <tbody> <tr> <td>J-K</td> <td>•</td> </tr> </tbody> </table>	ACTION	CODE	J-K	•
ACTION	CODE								
J-K OR D (CONTROLLED)	A								
ACTION	CODE								
J-K	•								

Notes on following page.

Programmable logic sequencer (16 × 45 × 12)

PLS155

“OR” ARRAY – ($Q_n = D$ -Type)

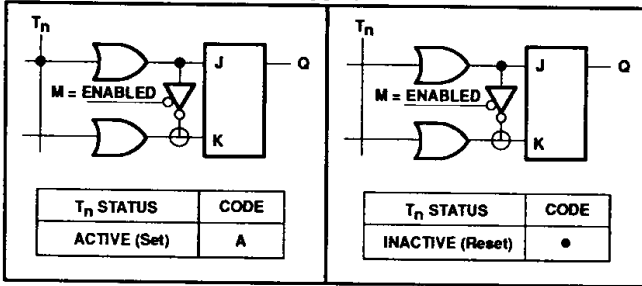

“OR” ARRAY – ($Q_n = J$ -K Type)

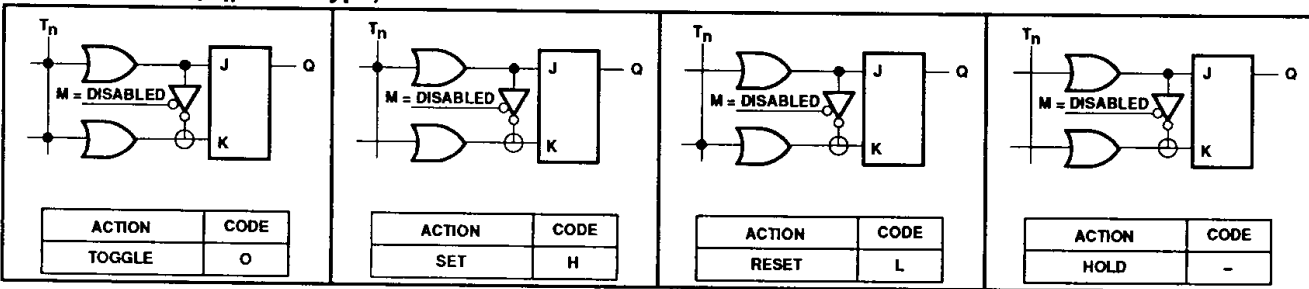

“OR” ARRAY – (S or B), (P), (R)

“EX-OR” ARRAY – (B)

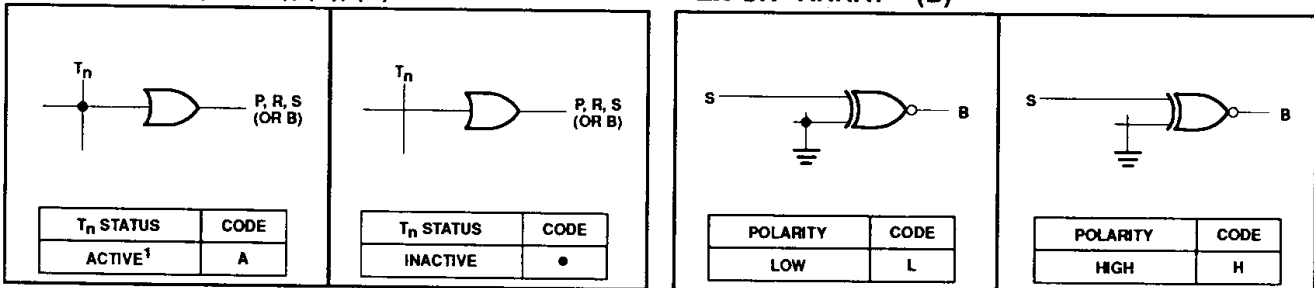

“OE” ARRAY – (E)

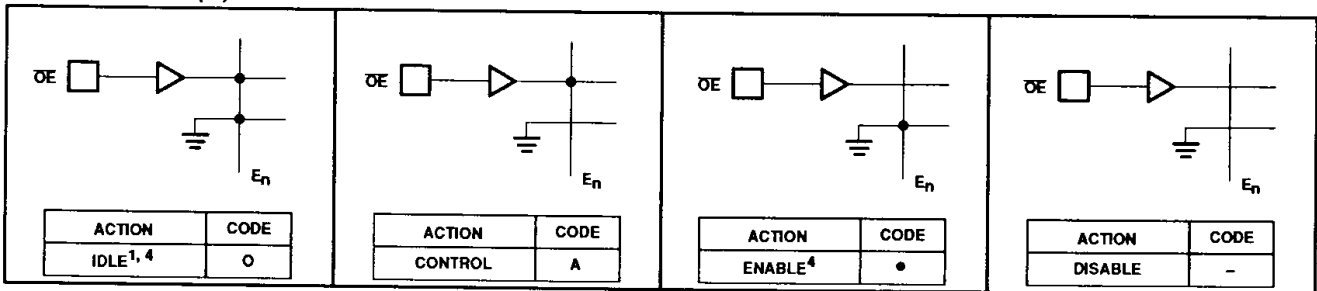

NOTES:

1. This is the initial unprogrammed state of all link pairs. It is normally associated with all unused (inactive) AND gates.
2. Any gate (T, F_C, L, P, R, D)_n will be unconditionally inhibited if both of the I, B, or Q links are left intact.
3. To prevent oscillations, this state is not allowed for C link pairs coupled to active gates T_n, F_C .
4. $E_n = O$ and $E_n = \bullet$ are logically equivalent states, since both cause F_n outputs to be unconditionally enabled.
5. These states are not allowed for control gates (L, P, R, D)_n due to their lack of “OR” array links.

Programmable logic sequencer (16 × 45 × 12)

PLS155

PROGRAM TABLE

AND		OR		CONTROL		NOTES																																																
<table border="1" style="width:100%; border-collapse: collapse;"> <tr><td>INACTIVE</td><td>O</td></tr> <tr><td>I, B, Q</td><td>H</td></tr> <tr><td>I, B, Q</td><td>L</td></tr> <tr><td>DON'T CARE</td><td>-</td></tr> </table>	INACTIVE	O	I, B, Q	H	I, B, Q	L	DON'T CARE	-	<table border="1" style="width:100%; border-collapse: collapse;"> <tr><td>ACTIVE</td><td>A</td></tr> <tr><td>INACTIVE</td><td>•</td></tr> </table>	ACTIVE	A	INACTIVE	•	<table border="1" style="width:100%; border-collapse: collapse;"> <tr><td>J/K</td><td>•</td></tr> <tr><td>J/K or D</td><td>A</td></tr> <tr><td>(controlled)</td><td></td></tr> </table>	J/K	•	J/K or D	A	(controlled)		<table border="1" style="width:100%; border-collapse: collapse;"> <tr><td>IDLE</td><td>O</td></tr> <tr><td>CONTROL</td><td>A</td></tr> <tr><td>ENABLE</td><td>•</td></tr> <tr><td>DISABLE</td><td>-</td></tr> </table>	IDLE	O	CONTROL	A	ENABLE	•	DISABLE	-	<table border="1" style="width:100%; border-collapse: collapse;"> <tr><td>TOGGLE</td><td>O</td></tr> <tr><td>SET</td><td>H</td></tr> <tr><td>RESET</td><td>L</td></tr> <tr><td>HOLD</td><td>-</td></tr> </table>		TOGGLE	O	SET	H	RESET	L	HOLD	-	<table border="1" style="width:100%; border-collapse: collapse;"> <tr><td>HIGH</td><td>H</td></tr> <tr><td>LOW</td><td>L</td></tr> </table>		HIGH	H	LOW	L	<table border="1" style="width:100%; border-collapse: collapse;"> <tr><td>F/F MODE</td><td></td></tr> </table>	F/F MODE		<table border="1" style="width:100%; border-collapse: collapse;"> <tr><td>E_B</td><td>E_A</td></tr> </table>	E _B	E _A	<table border="1" style="width:100%; border-collapse: collapse;"> <tr><td colspan="2">POLARITY</td></tr> </table>	POLARITY	
INACTIVE	O																																																					
I, B, Q	H																																																					
I, B, Q	L																																																					
DON'T CARE	-																																																					
ACTIVE	A																																																					
INACTIVE	•																																																					
J/K	•																																																					
J/K or D	A																																																					
(controlled)																																																						
IDLE	O																																																					
CONTROL	A																																																					
ENABLE	•																																																					
DISABLE	-																																																					
TOGGLE	O																																																					
SET	H																																																					
RESET	L																																																					
HOLD	-																																																					
HIGH	H																																																					
LOW	L																																																					
F/F MODE																																																						
E _B	E _A																																																					
POLARITY																																																						
<table border="1" style="width:100%; border-collapse: collapse;"> <tr><td>INACTIVE</td><td>O</td></tr> <tr><td>GENERATE</td><td>A</td></tr> <tr><td>PROPAGATE</td><td>•</td></tr> <tr><td>TRANSPARENT</td><td>-</td></tr> </table>		INACTIVE	O	GENERATE	A	PROPAGATE	•	TRANSPARENT	-	<table border="1" style="width:100%; border-collapse: collapse;"> <tr><td>J/K</td><td>•</td></tr> <tr><td>J/K or D</td><td>A</td></tr> <tr><td>(controlled)</td><td></td></tr> </table>		J/K	•	J/K or D	A	(controlled)		<table border="1" style="width:100%; border-collapse: collapse;"> <tr><td>HIGH</td><td>H</td></tr> <tr><td>LOW</td><td>L</td></tr> </table>		HIGH	H	LOW	L	<table border="1" style="width:100%; border-collapse: collapse;"> <tr><td>F/F MODE</td><td></td></tr> </table>		F/F MODE		<table border="1" style="width:100%; border-collapse: collapse;"> <tr><td>E_B</td><td>E_A</td></tr> </table>		E _B	E _A	<table border="1" style="width:100%; border-collapse: collapse;"> <tr><td colspan="2">POLARITY</td></tr> </table>		POLARITY																				
INACTIVE	O																																																					
GENERATE	A																																																					
PROPAGATE	•																																																					
TRANSPARENT	-																																																					
J/K	•																																																					
J/K or D	A																																																					
(controlled)																																																						
HIGH	H																																																					
LOW	L																																																					
F/F MODE																																																						
E _B	E _A																																																					
POLARITY																																																						
<table border="1" style="width:100%; border-collapse: collapse;"> <tr><td>INACTIVE</td><td>O</td></tr> <tr><td>GENERATE</td><td>A</td></tr> <tr><td>PROPAGATE</td><td>•</td></tr> <tr><td>TRANSPARENT</td><td>-</td></tr> </table>		INACTIVE	O	GENERATE	A	PROPAGATE	•	TRANSPARENT	-	<table border="1" style="width:100%; border-collapse: collapse;"> <tr><td>J/K</td><td>•</td></tr> <tr><td>J/K or D</td><td>A</td></tr> <tr><td>(controlled)</td><td></td></tr> </table>		J/K	•	J/K or D	A	(controlled)		<table border="1" style="width:100%; border-collapse: collapse;"> <tr><td>HIGH</td><td>H</td></tr> <tr><td>LOW</td><td>L</td></tr> </table>		HIGH	H	LOW	L	<table border="1" style="width:100%; border-collapse: collapse;"> <tr><td>F/F MODE</td><td></td></tr> </table>		F/F MODE		<table border="1" style="width:100%; border-collapse: collapse;"> <tr><td>E_B</td><td>E_A</td></tr> </table>		E _B	E _A	<table border="1" style="width:100%; border-collapse: collapse;"> <tr><td colspan="2">POLARITY</td></tr> </table>		POLARITY																				
INACTIVE	O																																																					
GENERATE	A																																																					
PROPAGATE	•																																																					
TRANSPARENT	-																																																					
J/K	•																																																					
J/K or D	A																																																					
(controlled)																																																						
HIGH	H																																																					
LOW	L																																																					
F/F MODE																																																						
E _B	E _A																																																					
POLARITY																																																						
<table border="1" style="width:100%; border-collapse: collapse;"> <tr><td>INACTIVE</td><td>O</td></tr> <tr><td>GENERATE</td><td>A</td></tr> <tr><td>PROPAGATE</td><td>•</td></tr> <tr><td>TRANSPARENT</td><td>-</td></tr> </table>		INACTIVE	O	GENERATE	A	PROPAGATE	•	TRANSPARENT	-	<table border="1" style="width:100%; border-collapse: collapse;"> <tr><td>J/K</td><td>•</td></tr> <tr><td>J/K or D</td><td>A</td></tr> <tr><td>(controlled)</td><td></td></tr> </table>		J/K	•	J/K or D	A	(controlled)		<table border="1" style="width:100%; border-collapse: collapse;"> <tr><td>HIGH</td><td>H</td></tr> <tr><td>LOW</td><td>L</td></tr> </table>		HIGH	H	LOW	L	<table border="1" style="width:100%; border-collapse: collapse;"> <tr><td>F/F MODE</td><td></td></tr> </table>		F/F MODE		<table border="1" style="width:100%; border-collapse: collapse;"> <tr><td>E_B</td><td>E_A</td></tr> </table>		E _B	E _A	<table border="1" style="width:100%; border-collapse: collapse;"> <tr><td colspan="2">POLARITY</td></tr> </table>		POLARITY																				
INACTIVE	O																																																					
GENERATE	A																																																					
PROPAGATE	•																																																					
TRANSPARENT	-																																																					
J/K	•																																																					
J/K or D	A																																																					
(controlled)																																																						
HIGH	H																																																					
LOW	L																																																					
F/F MODE																																																						
E _B	E _A																																																					
POLARITY																																																						
<table border="1" style="width:100%; border-collapse: collapse;"> <tr><td>INACTIVE</td><td>O</td></tr> <tr><td>GENERATE</td><td>A</td></tr> <tr><td>PROPAGATE</td><td>•</td></tr> <tr><td>TRANSPARENT</td><td>-</td></tr> </table>		INACTIVE	O	GENERATE	A	PROPAGATE	•	TRANSPARENT	-	<table border="1" style="width:100%; border-collapse: collapse;"> <tr><td>J/K</td><td>•</td></tr> <tr><td>J/K or D</td><td>A</td></tr> <tr><td>(controlled)</td><td></td></tr> </table>		J/K	•	J/K or D	A	(controlled)		<table border="1" style="width:100%; border-collapse: collapse;"> <tr><td>HIGH</td><td>H</td></tr> <tr><td>LOW</td><td>L</td></tr> </table>		HIGH	H	LOW	L	<table border="1" style="width:100%; border-collapse: collapse;"> <tr><td>F/F MODE</td><td></td></tr> </table>		F/F MODE		<table border="1" style="width:100%; border-collapse: collapse;"> <tr><td>E_B</td><td>E_A</td></tr> </table>		E _B	E _A	<table border="1" style="width:100%; border-collapse: collapse;"> <tr><td colspan="2">POLARITY</td></tr> </table>		POLARITY																				
INACTIVE	O																																																					
GENERATE	A																																																					
PROPAGATE	•																																																					
TRANSPARENT	-																																																					
J/K	•																																																					
J/K or D	A																																																					
(controlled)																																																						
HIGH	H																																																					
LOW	L																																																					
F/F MODE																																																						
E _B	E _A																																																					
POLARITY																																																						
<table border="1" style="width:100%; border-collapse: collapse;"> <tr><td>INACTIVE</td><td>O</td></tr> <tr><td>GENERATE</td><td>A</td></tr> <tr><td>PROPAGATE</td><td>•</td></tr> <tr><td>TRANSPARENT</td><td>-</td></tr> </table>		INACTIVE	O	GENERATE	A	PROPAGATE	•	TRANSPARENT	-	<table border="1" style="width:100%; border-collapse: collapse;"> <tr><td>J/K</td><td>•</td></tr> <tr><td>J/K or D</td><td>A</td></tr> <tr><td>(controlled)</td><td></td></tr> </table>		J/K	•	J/K or D	A	(controlled)		<table border="1" style="width:100%; border-collapse: collapse;"> <tr><td>HIGH</td><td>H</td></tr> <tr><td>LOW</td><td>L</td></tr> </table>		HIGH	H	LOW	L	<table border="1" style="width:100%; border-collapse: collapse;"> <tr><td>F/F MODE</td><td></td></tr> </table>		F/F MODE		<table border="1" style="width:100%; border-collapse: collapse;"> <tr><td>E_B</td><td>E_A</td></tr> </table>		E _B	E _A	<table border="1" style="width:100%; border-collapse: collapse;"> <tr><td colspan="2">POLARITY</td></tr> </table>		POLARITY																				
INACTIVE	O																																																					
GENERATE	A																																																					
PROPAGATE	•																																																					
TRANSPARENT	-																																																					
J/K	•																																																					
J/K or D	A																																																					
(controlled)																																																						
HIGH	H																																																					
LOW	L																																																					
F/F MODE																																																						
E _B	E _A																																																					
POLARITY																																																						
<table border="1" style="width:100%; border-collapse: collapse;"> <tr><td>INACTIVE</td><td>O</td></tr> <tr><td>GENERATE</td><td>A</td></tr> <tr><td>PROPAGATE</td><td>•</td></tr> <tr><td>TRANSPARENT</td><td>-</td></tr> </table>		INACTIVE	O	GENERATE	A	PROPAGATE	•	TRANSPARENT	-	<table border="1" style="width:100%; border-collapse: collapse;"> <tr><td>J/K</td><td>•</td></tr> <tr><td>J/K or D</td><td>A</td></tr> <tr><td>(controlled)</td><td></td></tr> </table>		J/K	•	J/K or D	A	(controlled)		<table border="1" style="width:100%; border-collapse: collapse;"> <tr><td>HIGH</td><td>H</td></tr> <tr><td>LOW</td><td>L</td></tr> </table>		HIGH	H	LOW	L	<table border="1" style="width:100%; border-collapse: collapse;"> <tr><td>F/F MODE</td><td></td></tr> </table>		F/F MODE		<table border="1" style="width:100%; border-collapse: collapse;"> <tr><td>E_B</td><td>E_A</td></tr> </table>		E _B	E _A	<table border="1" style="width:100%; border-collapse: collapse;"> <tr><td colspan="2">POLARITY</td></tr> </table>		POLARITY																				
INACTIVE	O																																																					
GENERATE	A																																																					
PROPAGATE	•																																																					
TRANSPARENT	-																																																					
J/K	•																																																					
J/K or D	A																																																					
(controlled)																																																						
HIGH	H																																																					
LOW	L																																																					
F/F MODE																																																						
E _B	E _A																																																					
POLARITY																																																						
<table border="1" style="width:100%; border-collapse: collapse;"> <tr><td>INACTIVE</td><td>O</td></tr> <tr><td>GENERATE</td><td>A</td></tr> <tr><td>PROPAGATE</td><td>•</td></tr> <tr><td>TRANSPARENT</td><td>-</td></tr> </table>		INACTIVE	O	GENERATE	A	PROPAGATE	•	TRANSPARENT	-	<table border="1" style="width:100%; border-collapse: collapse;"> <tr><td>J/K</td><td>•</td></tr> <tr><td>J/K or D</td><td>A</td></tr> <tr><td>(controlled)</td><td></td></tr> </table>		J/K	•	J/K or D	A	(controlled)		<table border="1" style="width:100%; border-collapse: collapse;"> <tr><td>HIGH</td><td>H</td></tr> <tr><td>LOW</td><td>L</td></tr> </table>		HIGH	H	LOW	L	<table border="1" style="width:100%; border-collapse: collapse;"> <tr><td>F/F MODE</td><td></td></tr> </table>		F/F MODE		<table border="1" style="width:100%; border-collapse: collapse;"> <tr><td>E_B</td><td>E_A</td></tr> </table>		E _B	E _A	<table border="1" style="width:100%; border-collapse: collapse;"> <tr><td colspan="2">POLARITY</td></tr> </table>		POLARITY																				
INACTIVE	O																																																					
GENERATE	A																																																					
PROPAGATE	•																																																					
TRANSPARENT	-																																																					
J/K	•																																																					
J/K or D	A																																																					
(controlled)																																																						
HIGH	H																																																					
LOW	L																																																					
F/F MODE																																																						
E _B	E _A																																																					
POLARITY																																																						
<table border="1" style="width:100%; border-collapse: collapse;"> <tr><td>INACTIVE</td><td>O</td></tr> <tr><td>GENERATE</td><td>A</td></tr> <tr><td>PROPAGATE</td><td>•</td></tr> <tr><td>TRANSPARENT</td><td>-</td></tr> </table>		INACTIVE	O	GENERATE	A	PROPAGATE	•	TRANSPARENT	-	<table border="1" style="width:100%; border-collapse: collapse;"> <tr><td>J/K</td><td>•</td></tr> <tr><td>J/K or D</td><td>A</td></tr> <tr><td>(controlled)</td><td></td></tr> </table>		J/K	•	J/K or D	A	(controlled)		<table border="1" style="width:100%; border-collapse: collapse;"> <tr><td>HIGH</td><td>H</td></tr> <tr><td>LOW</td><td>L</td></tr> </table>		HIGH	H	LOW	L	<table border="1" style="width:100%; border-collapse: collapse;"> <tr><td>F/F MODE</td><td></td></tr> </table>		F/F MODE		<table border="1" style="width:100%; border-collapse: collapse;"> <tr><td>E_B</td><td>E_A</td></tr> </table>		E _B	E _A	<table border="1" style="width:100%; border-collapse: collapse;"> <tr><td colspan="2">POLARITY</td></tr> </table>		POLARITY																				
INACTIVE	O																																																					
GENERATE	A																																																					
PROPAGATE	•																																																					
TRANSPARENT	-																																																					
J/K	•																																																					
J/K or D	A																																																					
(controlled)																																																						
HIGH	H																																																					
LOW	L																																																					
F/F MODE																																																						
E _B	E _A																																																					
POLARITY																																																						
<table border="1" style="width:100%; border-collapse: collapse;"> <tr><td>INACTIVE</td><td>O</td></tr> <tr><td>GENERATE</td><td>A</td></tr> <tr><td>PROPAGATE</td><td>•</td></tr> <tr><td>TRANSPARENT</td><td>-</td></tr> </table>		INACTIVE	O	GENERATE	A	PROPAGATE	•	TRANSPARENT	-	<table border="1" style="width:100%; border-collapse: collapse;"> <tr><td>J/K</td><td>•</td></tr> <tr><td>J/K or D</td><td>A</td></tr> <tr><td>(controlled)</td><td></td></tr> </table>		J/K	•	J/K or D	A	(controlled)		<table border="1" style="width:100%; border-collapse: collapse;"> <tr><td>HIGH</td><td>H</td></tr> <tr><td>LOW</td><td>L</td></tr> </table>		HIGH	H	LOW	L	<table border="1" style="width:100%; border-collapse: collapse;"> <tr><td>F/F MODE</td><td></td></tr> </table>		F/F MODE		<table border="1" style="width:100%; border-collapse: collapse;"> <tr><td>E_B</td><td>E_A</td></tr> </table>		E _B	E _A	<table border="1" style="width:100%; border-collapse: collapse;"> <tr><td colspan="2">POLARITY</td></tr> </table>		POLARITY																				
INACTIVE	O																																																					
GENERATE	A																																																					
PROPAGATE	•																																																					
TRANSPARENT	-																																																					
J/K	•																																																					
J/K or D	A																																																					
(controlled)																																																						
HIGH	H																																																					
LOW	L																																																					
F/F MODE																																																						
E _B	E _A																																																					
POLARITY																																																						
<table border="1" style="width:100%; border-collapse: collapse;"> <tr><td>INACTIVE</td><td>O</td></tr> <tr><td>GENERATE</td><td>A</td></tr> <tr><td>PROPAGATE</td><td>•</td></tr> <tr><td>TRANSPARENT</td><td>-</td></tr> </table>		INACTIVE	O	GENERATE	A	PROPAGATE	•	TRANSPARENT	-	<table border="1" style="width:100%; border-collapse: collapse;"> <tr><td>J/K</td><td>•</td></tr> <tr><td>J/K or D</td><td>A</td></tr> <tr><td>(controlled)</td><td></td></tr> </table>		J/K	•	J/K or D	A	(controlled)		<table border="1" style="width:100%; border-collapse: collapse;"> <tr><td>HIGH</td><td>H</td></tr> <tr><td>LOW</td><td>L</td></tr> </table>		HIGH	H	LOW	L	<table border="1" style="width:100%; border-collapse: collapse;"> <tr><td>F/F MODE</td><td></td></tr> </table>		F/F MODE		<table border="1" style="width:100%; border-collapse: collapse;"> <tr><td>E_B</td><td>E_A</td></tr> </table>		E _B	E _A	<table border="1" style="width:100%; border-collapse: collapse;"> <tr><td colspan="2">POLARITY</td></tr> </table>		POLARITY																				
INACTIVE	O																																																					
GENERATE	A																																																					
PROPAGATE	•																																																					
TRANSPARENT	-																																																					
J/K	•																																																					
J/K or D	A																																																					
(controlled)																																																						
HIGH	H																																																					
LOW	L																																																					
F/F MODE																																																						
E _B	E _A																																																					
POLARITY																																																						
<table border="1" style="width:100%; border-collapse: collapse;"> <tr><td>INACTIVE</td><td>O</td></tr> <tr><td>GENERATE</td><td>A</td></tr> <tr><td>PROPAGATE</td><td>•</td></tr> <tr><td>TRANSPARENT</td><td>-</td></tr> </table>		INACTIVE	O	GENERATE	A	PROPAGATE	•	TRANSPARENT	-	<table border="1" style="width:100%; border-collapse: collapse;"> <tr><td>J/K</td><td>•</td></tr> <tr><td>J/K or D</td><td>A</td></tr> <tr><td>(controlled)</td><td></td></tr> </table>		J/K	•	J/K or D	A	(controlled)		<table border="1" style="width:100%; border-collapse: collapse;"> <tr><td>HIGH</td><td>H</td></tr> <tr><td>LOW</td><td>L</td></tr> </table>		HIGH	H	LOW	L	<table border="1" style="width:100%; border-collapse: collapse;"> <tr><td>F/F MODE</td><td></td></tr> </table>		F/F MODE		<table border="1" style="width:100%; border-collapse: collapse;"> <tr><td>E_B</td><td>E_A</td></tr> </table>		E _B	E _A	<table border="1" style="width:100%; border-collapse: collapse;"> <tr><td colspan="2">POLARITY</td></tr> </table>		POLARITY																				
INACTIVE	O																																																					
GENERATE	A																																																					
PROPAGATE	•																																																					
TRANSPARENT	-																																																					
J/K	•																																																					
J/K or D	A																																																					
(controlled)																																																						
HIGH	H																																																					
LOW	L																																																					
F/F MODE																																																						
E _B	E _A																																																					
POLARITY																																																						
<table border="1" style="width:100%; border-collapse: collapse;"> <tr><td>INACTIVE</td><td>O</td></tr> <tr><td>GENERATE</td><td>A</td></tr> <tr><td>PROPAGATE</td><td>•</td></tr> <tr><td>TRANSPARENT</td><td>-</td></tr> </table>		INACTIVE	O	GENERATE	A	PROPAGATE	•	TRANSPARENT	-	<table border="1" style="width:100%; border-collapse: collapse;"> <tr><td>J/K</td><td>•</td></tr> <tr><td>J/K or D</td><td>A</td></tr> <tr><td>(controlled)</td><td></td></tr> </table>		J/K	•	J/K or D	A	(controlled)		<table border="1" style="width:100%; border-collapse: collapse;"> <tr><td>HIGH</td><td>H</td></tr> <tr><td>LOW</td><td>L</td></tr> </table>		HIGH	H	LOW	L	<table border="1" style="width:100%; border-collapse: collapse;"> <tr><td>F/F MODE</td><td></td></tr> </table>		F/F MODE		<table border="1" style="width:100%; border-collapse: collapse;"> <tr><td>E_B</td><td>E_A</td></tr> </table>		E _B	E _A	<table border="1" style="width:100%; border-collapse: collapse;"> <tr><td colspan="2">POLARITY</td></tr> </table>		POLARITY																				
INACTIVE	O																																																					
GENERATE	A																																																					
PROPAGATE	•																																																					
TRANSPARENT	-																																																					
J/K	•																																																					
J/K or D	A																																																					
(controlled)																																																						
HIGH	H																																																					
LOW	L																																																					
F/F MODE																																																						
E _B	E _A																																																					
POLARITY																																																						
<table border="1" style="width:100%; border-collapse: collapse;"> <tr><td>INACTIVE</td><td>O</td></tr> <tr><td>GENERATE</td><td>A</td></tr> <tr><td>PROPAGATE</td><td>•</td></tr> <tr><td>TRANSPARENT</td><td>-</td></tr> </table>		INACTIVE	O	GENERATE	A	PROPAGATE	•	TRANSPARENT	-	<table border="1" style="width:100%; border-collapse: collapse;"> <tr><td>J/K</td><td>•</td></tr> <tr><td>J/K or D</td><td>A</td></tr> <tr><td>(controlled)</td><td></td></tr> </table>		J/K	•	J/K or D	A	(controlled)		<table border="1" style="width:100%; border-collapse: collapse;"> <tr><td>HIGH</td><td>H</td></tr> <tr><td>LOW</td><td>L</td></tr> </table>		HIGH	H	LOW	L	<table border="1" style="width:100%; border-collapse: collapse;"> <tr><td>F/F MODE</td><td></td></tr> </table>		F/F MODE		<table border="1" style="width:100%; border-collapse: collapse;"> <tr><td>E_B</td><td>E_A</td></tr> </table>		E _B	E _A	<table border="1" style="width:100%; border-collapse: collapse;"> <tr><td colspan="2">POLARITY</td></tr> </table>		POLARITY																				
INACTIVE	O																																																					
GENERATE	A																																																					
PROPAGATE	•																																																					
TRANSPARENT	-																																																					
J/K	•																																																					
J/K or D	A																																																					
(controlled)																																																						
HIGH	H																																																					
LOW	L																																																					
F/F MODE																																																						
E _B	E _A																																																					
POLARITY																																																						
<table border="1" style="width:100%; border-collapse: collapse;"> <tr><td>INACTIVE</td><td>O</td></tr> <tr><td>GENERATE</td><td>A</td></tr> <tr><td>PROPAGATE</td><td>•</td></tr> <tr><td>TRANSPARENT</td><td>-</td></tr> </table>		INACTIVE	O	GENERATE	A	PROPAGATE	•	TRANSPARENT	-	<table border="1" style="width:100%; border-collapse: collapse;"> <tr><td>J/K</td><td>•</td></tr> <tr><td>J/K or D</td><td>A</td></tr> <tr><td>(controlled)</td><td></td></tr> </table>		J/K	•	J/K or D	A	(controlled)		<table border="1" style="width:100%; border-collapse: collapse;"> <tr><td>HIGH</td><td>H</td></tr> <tr><td>LOW</td><td>L</td></tr> </table>		HIGH	H	LOW	L	<table border="1" style="width:100%; border-collapse: collapse;"> <tr><td>F/F MODE</td><td></td></tr> </table>		F/F MODE		<table border="1" style="width:100%; border-collapse: collapse;"> <tr><td>E_B</td><td>E_A</td></tr> </table>		E _B	E _A	<table border="1" style="width:100%; border-collapse: collapse;"> <tr><td colspan="2">POLARITY</td></tr> </table>		POLARITY																				
INACTIVE	O																																																					
GENERATE	A																																																					
PROPAGATE	•																																																					
TRANSPARENT	-																																																					
J/K	•																																																					
J/K or D	A																																																					
(controlled)																																																						
HIGH	H																																																					
LOW	L																																																					
F/F MODE																																																						
E _B	E _A																																																					
POLARITY																																																						
<table border="1" style="width:100%; border-collapse: collapse;"> <tr><td>INACTIVE</td><td>O</td></tr> <tr><td>GENERATE</td><td>A</td></tr> <tr><td>PROPAGATE</td><td>•</td></tr> <tr><td>TRANSPARENT</td><td>-</td></tr> </table>		INACTIVE	O	GENERATE	A	PROPAGATE	•	TRANSPARENT	-	<table border="1" style="width:100%; border-collapse: collapse;"> <tr><td>J/K</td><td>•</td></tr> <tr><td>J/K or D</td><td>A</td></tr> <tr><td>(controlled)</td><td></td></tr> </table>		J/K	•	J/K or D	A	(controlled)		<table border="1" style="width:100%; border-collapse: collapse;"> <tr><td>HIGH</td><td>H</td></tr> <tr><td>LOW</td><td>L</td></tr> </table>		HIGH	H	LOW	L	<table border="1" style="width:100%; border-collapse: collapse;"> <tr><td>F/F MODE</td><td></td></tr> </table>		F/F MODE		<table border="1" style="width:100%; border-collapse: collapse;"> <tr><td>E_B</td><td>E_A</td></tr> </table>		E _B	E _A	<table border="1" style="width:100%; border-collapse: collapse;"> <tr><td colspan="2">POLARITY</td></tr> </table>		POLARITY																				
INACTIVE	O																																																					
GENERATE	A																																																					
PROPAGATE	•																																																					
TRANSPARENT	-																																																					
J/K	•																																																					
J/K or D	A																																																					
(controlled)																																																						
HIGH	H																																																					
LOW	L																																																					
F/F MODE																																																						
E _B	E _A																																																					
POLARITY																																																						
<table border="1" style="width:100%; border-collapse: collapse;"> <tr><td>INACTIVE</td><td>O</td></tr> <tr><td>GENERATE</td><td>A</td></tr> <tr><td>PROPAGATE</td><td>•</td></tr> <tr><td>TRANSPARENT</td><td>-</td></tr> </table>		INACTIVE	O	GENERATE	A	PROPAGATE	•	TRANSPARENT	-	<table border="1" style="width:100%; border-collapse: collapse;"> <tr><td>J/K</td><td>•</td></tr> <tr><td>J/K or D</td><td>A</td></tr> <tr><td>(controlled)</td><td></td></tr> </table>		J/K	•	J/K or D	A	(controlled)		<table border="1" style="width:100%; border-collapse: collapse;"> <tr><td>HIGH</td><td>H</td></tr> <tr><td>LOW</td><td>L</td></tr> </table>		HIGH	H	LOW	L	<table border="1" style="width:100%; border-collapse: collapse;"> <tr><td>F/F MODE</td><td></td></tr> </table>		F/F MODE		<table border="1" style="width:100%; border-collapse: collapse;"> <tr><td>E_B</td><td>E_A</td></tr> </table>		E _B	E _A	<table border="1" style="width:100%; border-collapse: collapse;"> <tr><td colspan="2">POLARITY</td></tr> </table>		POLARITY																				
INACTIVE	O																																																					
GENERATE	A																																																					
PROPAGATE	•																																																					
TRANSPARENT	-																																																					
J/K	•																																																					
J/K or D	A																																																					
(controlled)																																																						
HIGH	H																																																					
LOW	L																																																					
F/F MODE																																																						
E _B	E _A																																																					
POLARITY																																																						
<table border="1" style="width:100%; border-collapse: collapse;"> <tr><td>INACTIVE</td><td>O</td></tr> <tr><td>GENERATE</td><td>A</td></tr> <tr><td>PROPAGATE</td><td>•</td></tr> <tr><td>TRANSPARENT</td><td>-</td></tr> </table>		INACTIVE	O	GENERATE	A	PROPAGATE	•	TRANSPARENT	-	<table border="1" style="width:100%; border-collapse: collapse;"> <tr><td>J/K</td><td>•</td></tr> <tr><td>J/K or D</td><td>A</td></tr> <tr><td>(controlled)</td><td></td></tr> </table>		J/K	•	J/K or D	A	(controlled)		<table border="1" style="width:100%; border-collapse: collapse;"> <tr><td>HIGH</td><td>H</td></tr> <tr><td>LOW</td><td>L</td></tr> </table>		HIGH	H	LOW	L	<table border="1" style="width:100%; border-collapse: collapse;"> <tr><td>F/F MODE</td><td></td></tr> </table>		F/F MODE		<table border="1" style="width:100%; border-collapse: collapse;"> <tr><td>E_B</td><td>E_A</td></tr> </table>		E _B	E _A	<table border="1" style="width:100%; border-collapse: collapse;"> <tr><td colspan="2">POLARITY</td></tr> </table>		POLARITY																				
INACTIVE	O																																																					
GENERATE	A																																																					
PROPAGATE	•																																																					
TRANSPARENT	-																																																					
J/K	•																																																					
J/K or D	A																																																					
(controlled)																																																						
HIGH	H																																																					
LOW	L																																																					
F/F MODE																																																						
E _B	E _A																																																					
POLARITY																																																						
<table border="1" style="width:100%; border-collapse: collapse;"> <tr><td>INACTIVE</td><td>O</td></tr> <tr><td>GENERATE</td><td>A</td></tr> <tr><td>PROPAGATE</td><td>•</td></tr> <tr><td>TRANSPARENT</td><td>-</td></tr> </table>		INACTIVE	O	GENERATE	A	PROPAGATE	•	TRANSPARENT	-	<table border="1" style="width:100%; border-collapse: collapse;"> <tr><td>J/K</td><td>•</td></tr> <tr><td>J/K or D</td><td>A</td></tr> <tr><td>(controlled)</td><td></td></tr> </table>		J/K	•	J/K or D	A	(controlled)		<table border="1" style="width:100%; border-collapse: collapse;"> <tr><td>HIGH</td><td>H</td></tr> <tr><td>LOW</td><td>L</td></tr> </table>		HIGH	H	LOW	L	<table border="1" style="width:100%; border-collapse: collapse;"> <tr><td>F/F MODE</td><td></td></tr> </table>		F/F MODE		<table border="1" style="width:100%; border-collapse: collapse;"> <tr><td>E_B</td><td>E_A</td></tr> </table>		E _B	E _A	<table border="1" style="width:100%; border-collapse: collapse;"> <tr><td colspan="2">POLARITY</td></tr> </table>		POLARITY																				
INACTIVE	O																																																					
GENERATE	A																																																					
PROPAGATE	•																																																					
TRANSPARENT	-																																																					
J/K	•																																																					
J/K or D	A																																																					
(controlled)																																																						
HIGH	H																																																					
LOW	L																																																					
F/F MODE																																																						
E _B	E _A																																																					
POLARITY																																																						
<table border="1" style="width:100%; border-collapse: collapse;"> <tr><td>INACTIVE</td><td>O</td></tr> <tr><td>GENERATE</td><td>A</td></tr> <tr><td>PROPAGATE</td><td>•</td></tr> <tr><td>TRANSPARENT</td><td>-</td></tr> </table>		INACTIVE	O	GENERATE	A	PROPAGATE	•	TRANSPARENT	-	<table border="1" style="width:100%; border-collapse: collapse;"> <tr><td>J/K</td><td>•</td></tr> <tr><td>J/K or D</td><td>A</td></tr> <tr><td>(controlled)</td><td></td></tr> </table>		J/K	•	J/K or D	A	(controlled)		<table border="1" style="width:100%; border-collapse: collapse;"> <tr><td>HIGH</td><td>H</td></tr> <tr><td>LOW</td><td>L</td></tr> </table>		HIGH	H	LOW	L	<table border="1" style="width:100%; border-collapse: collapse;"> <tr><td>F/F MODE</td><td></td></tr> </table>		F/F MODE		<table border="1" style="width:100%; border-collapse: collapse;"> <tr><td>E_B</td><td>E_A</td></tr> </table>		E _B	E _A	<table border="1" style="width:100%; border-collapse: collapse;"> <tr><td colspan="2">POLARITY</td></tr> </table>		POLARITY																				
INACTIVE	O																																																					
GENERATE	A																																																					
PROPAGATE	•																																																					
TRANSPARENT	-																																																					
J/K	•																																																					
J/K or D	A																																																					
(controlled)																																																						
HIGH	H																																																					
LOW	L																																																					
F/F MODE																																																						
E _B	E _A																																																					
POLARITY																																																						
<table border="1" style="width:100%; border-collapse: collapse;"> <tr><td>INACTIVE</td><td>O</td></tr> <tr><td>GENERATE</td><td>A</td></tr> <tr><td>PROPAGATE</td><td>•</td></tr> <tr><td>TRANSPARENT</td><td>-</td></tr> </table>		INACTIVE	O	GENERATE	A	PROPAGATE	•	TRANSPARENT	-	<table border="1" style="width:100%; border-collapse: collapse;"> <tr><td>J/K</td><td>•</td></tr> <tr><td>J/K or D</td><td>A</td></tr> <tr><td>(controlled)</td><td></td></tr> </table>		J/K	•	J/K or D	A	(controlled)		<table border="1" style="width:100%; border-collapse: collapse;"> <tr><td>HIGH</td><td>H</td></tr> <tr><td>LOW</td><td>L</td></tr> </table>		HIGH	H	LOW	L	<table border="1" style="width:100%; border-collapse: collapse;"> <tr><td>F/F MODE</td><td></td></tr> </table>		F/F MODE		<table border="1" style="width:100%; border-collapse: collapse;"> <tr><td>E_B</td><td>E_A</td></tr> </table>		E _B	E _A	<table border="1" style="width:100%; border-collapse: collapse;"> <tr><td colspan="2">POLARITY</td></tr> </table>		POLARITY																				
INACTIVE	O																																																					
GENERATE	A																																																					
PROPAGATE	•																																																					
TRANSPARENT	-																																																					
J/K	•																																																					
J/K or D	A																																																					
(controlled)																																																						
HIGH	H																																																					
LOW	L																																																					
F/F MODE																																																						
E _B	E _A																																																					
POLARITY																																																						
<table border="1" style="width:100%; border-collapse: collapse;"> <tr><td>INACTIVE</td><td>O</td></tr> <tr><td>GENERATE</td><td>A</td></tr> <tr><td>PROPAGATE</td><td>•</td></tr> <tr><td>TRANSPARENT</td><td>-</td></tr> </table>		INACTIVE	O	GENERATE	A	PROPAGATE	•	TRANSPARENT	-	<table border="1" style="width:100%; border-collapse: collapse;"> <tr><td>J/K</td><td>•</td></tr> <tr><td>J/K or D</td><td>A</td></tr> <tr><td>(controlled)</td><td></td></tr> </table>		J/K	•	J/K or D	A	(controlled)		<table border="1" style="width:100%; border-collapse: collapse;"> <tr><td>HIGH</td><td>H</td></tr> <tr><td>LOW</td><td>L</td></tr> </table>		HIGH	H	LOW	L	<table border="1" style="width:100%; border-collapse: collapse;"> <tr><td>F/F MODE</td><td></td></tr> </table>		F/F MODE		<table border="1" style="width:100%; border-collapse: collapse;"> <tr><td>E_B</td><td>E_A</td></tr> </table>		E _B	E _A	<table border="1" style="width:100%; border-collapse: collapse;"> <tr><td colspan="2">POLARITY</td></tr> </table>		POLARITY																				
INACTIVE	O																																																					
GENERATE	A																																																					
PROPAGATE	•																																																					
TRANSPARENT	-																																																					
J/K	•																																																					
J/K or D	A																																																					
(controlled)																																																						
HIGH	H																																																					
LOW	L																																																					
F/F MODE																																																						
E _B	E _A																																																					
POLARITY																																																						
<table border="1" style="width:100%; border-collapse: collapse;"> <tr><td>INACTIVE</td><td>O</td></tr> <tr><td>GENERATE</td><td>A</td></tr> <tr><td>PROPAGATE</td><td>•</td></tr> <tr><td>TRANSPARENT</td><td>-</td></tr> </table>		INACTIVE	O	GENERATE	A	PROPAGATE	•	TRANSPARENT	-	<table border="1" style="width:100%; border-collapse: collapse;"> <tr><td>J/K</td><td>•</td></tr> <tr><td>J/K or D</td><td>A</td></tr> <tr><td>(controlled)</td><td></td></tr> </table>		J/K	•	J/K or D	A	(controlled)		<table border="1" style="width:100%; border-collapse: collapse;"> <tr><td>HIGH</td><td>H</td></tr> <tr><td>LOW</td><td>L</td></tr> </table>		HIGH	H	LOW	L	<table border="1" style="width:100%; border-collapse: collapse;"> <tr><td>F/F MODE</td><td></td></tr> </table>		F/F MODE		<table border="1" style="width:100%; border-collapse: collapse;"> <tr><td>E_B</td><td>E_A</td></tr> </table>		E _B	E _A	<table border="1" style="width:100%; border-collapse: collapse;"> <tr><td colspan="2">POLARITY</td></tr> </table>		POLARITY																				
INACTIVE	O																																																					
GENERATE	A																																																					
PROPAGATE	•																																																					
TRANSPARENT	-																																																					
J/K	•																																																					
J/K or D	A																																																					
(controlled)																																																						
HIGH	H																																																					
LOW	L																																																					
F/F MODE																																																						
E _B	E _A																																																					
POLARITY																																																						

Programmable logic sequencer (16 × 45 × 12)

PLS155

SNAP RESOURCE SUMMARY DESIGNATIONS

