



SC18IM700

Master I²C-bus controller with UART interface

Rev. 01 — 28 February 2006

Product data sheet

1. General description

The SC18IM700 is designed to serve as an interface between the standard UART port of a microcontroller or microprocessor and the serial I²C-bus; this allows the microcontroller or microprocessor to communicate directly with other I²C-bus devices. The SC18IM700 can operate as an I²C-bus master. The SC18IM700 controls all the I²C-bus specific sequences, protocol, arbitration and timing. The host communicates with SC18IM700 with ASCII messages protocol; this makes the control sequences from the host to the SC18IM700 become very simple.

2. Features

- UART host interface
- I²C-bus controller
- Eight programmable I/O pins
- High-speed UART: baud rate up to 460.8 kbit/s
- High-speed I²C-bus: 400 kbit/s
- 16-byte TXFIFO
- 16-byte RXFIFO
- Programmable baud rate generator
- 2.3 V and 3.6 V operation
- Sleep mode (power-down)
- UART message format resembles I²C-bus transaction format
- I²C-bus master functions
- Multi-master capability
- 5 V tolerance on the input pins
- 8 N 1 UART format (8 data bits, no parity bit, 1 stop bit)
- Available in very small TSSOP16 package

3. Applications

- Enable I²C-bus master support in a system
- I²C-bus instrumentation and control
- Industrial control
- Medical equipment
- Cellular telephones
- Handheld computers

PHILIPS

4. Ordering information

Table 1: Ordering information

Type number	Package		Version
	Name	Description	
SC18IM700IPW	TSSOP16	plastic thin shrink small outline package; 16 leads; body width 4.4 mm	SOT403-1

5. Block diagram

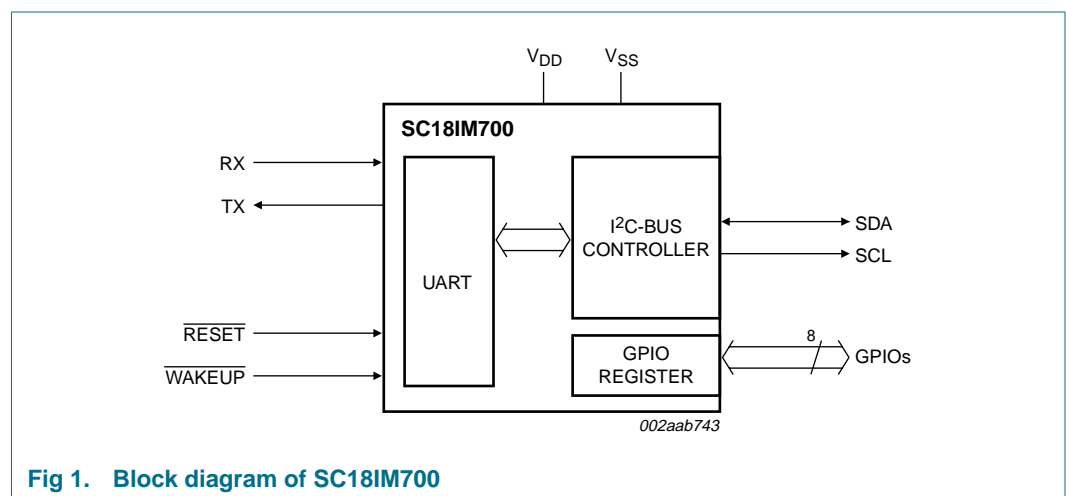
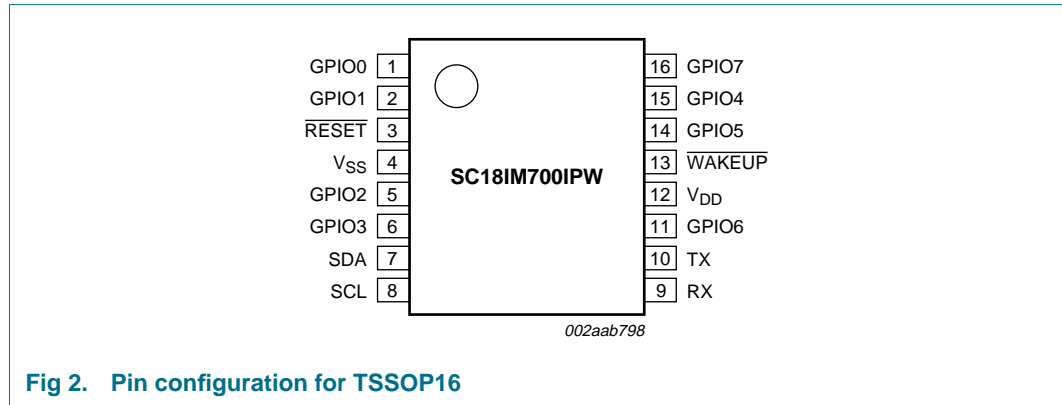

Fig 1. Block diagram of SC18IM700

6. Pinning information

6.1 Pinning



6.2 Pin description

Table 2: Pin description

Symbol	Pin	Type	Description
GPIO0	1	I/O	programmable I/O pin
GPIO1	2	I/O	programmable I/O pin
RESET	3	I	hardware reset input
V _{SS}	4	-	ground
GPIO2	5	I/O	programmable I/O pin
GPIO3	6	I/O	programmable I/O pin
SDA	7	I/O	I ² C-bus data pin
SCL	8	O	I ² C-bus clock output
RX	9	I	RS-232 receive input
TX	10	O	RS-232 transmit input
GPIO6	11	I/O	programmable I/O pin
V _{DD}	12	-	power supply
WAKEUP	13	I	Wake up SC18IM700 from Power-down mode. Pulling LOW by the host to wake up the device. A 1 kΩ resistor must be connected between V _{DD} and this pin.
GPIO5	14	I/O	programmable I/O pin
GPIO4	15	O	programmable I/O pin
GPIO7	16	O	programmable I/O pin

7. Functional description

The SC18IM700 is a bridge between a UART port and I²C-bus. The UART interface consists of a full-functional advanced UART. The UART communicates with the host through the TX and RX pins. The serial data format is fixed: one start bit, 8 data bits, and one stop bit. After reset the baud rate defaults to 9600 bit/s, and can be changed through the Baud Rate Generator (BRG) registers.

After a power-up sequence or a hardware reset, the SC18IM700 will send two continuous bytes to the host to indicate a start-up condition. These two bytes are 0x4F and 0x4B; 'OK' in ASCII.

7.1 UART message format

The host initiates an I²C-bus data transfer, reads from and writes to SC18IM700 internal registers through a series of ASCII commands. [Table 3](#) lists the ASCII commands supported by SC18IM700, and also their hexadecimal value representation. Unrecognized commands are ignored by the device.

To prevent the host from hanging the SC18IM700 due to an unfinished command sequence, the SC18IM700 has a time-out feature. The delay between any two bytes of data coming from the host should be less than 655 ms. If this condition is not met, the SC18IM700 will time-out and clear the receive buffer. The SC18IM700 then starts to wait for the next command from the host.

Table 3: ASCII commands supported by SC18IM700

ASCII command	Hex value	Command function
S	0x53	I ² C-bus START
P	0x50	I ² C-bus STOP
R	0x52	read SC18IM700 internal register
W	0x57	write to SC18IM700 internal register
I	0x49	read GPIO port
O	0x4F	write to GPIO port
Z	0x5A	power down

7.1.1 Write N bytes to slave device

The host issues the write command by sending an S character followed by an I²C-bus slave device address, the total number of bytes to be sent, and I²C-bus data which begins with the first byte (DATA 0) and ends with the last byte (DATA N). The frame is then terminated with a P character. Once the host issues this command, the SC18IM700 will access the I²C-bus slave device and start sending the I²C-bus data bytes.

Note that the second byte sent is the I²C-bus device slave address. The least significant bit (W) of this byte must be set to 0 to indicate this is an I²C-bus write command.

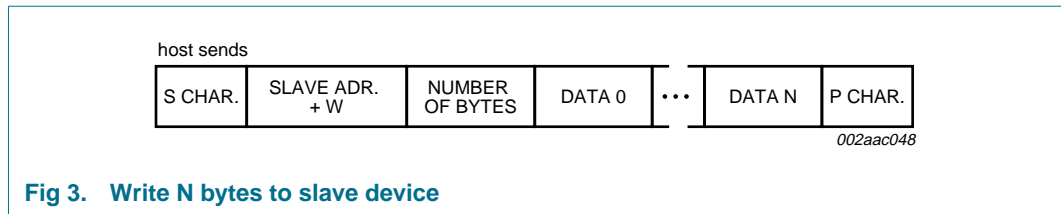

Fig 3. Write N bytes to slave device

7.1.2 Read N byte from slave device

The host issues the read command by sending an S character followed by an I²C-bus slave device address, and the total number of bytes to be read from the addressed I²C-bus slave. The frame is then terminated with a P character. Once the host issues this command, the SC18IM700 will access the I²C-bus slave device, get the correct number of bytes from the addressed I²C-bus slave, and then return the data to the host.

Note that the second byte sent is the I²C-bus device slave address. The least significant bit (R) of this byte must be set to 1 to indicate this is an I²C-bus write command.

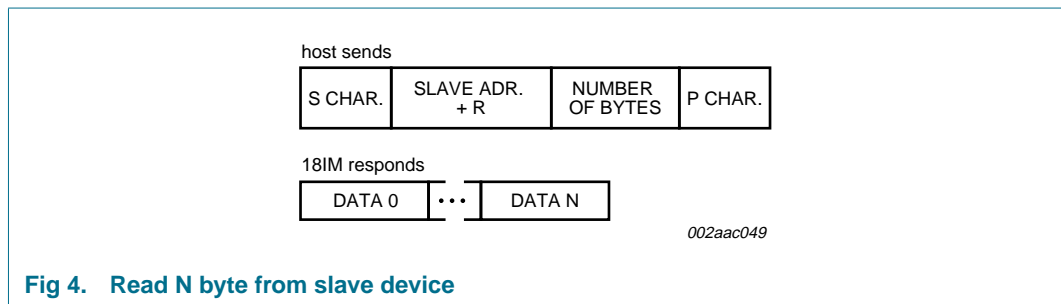

Fig 4. Read N byte from slave device

7.1.3 Write to 18IM internal register

The host issues the internal register write command by sending a W character followed by the register and data pair. Each register to be written must be followed by the data byte. The frame is then terminated with a P character.

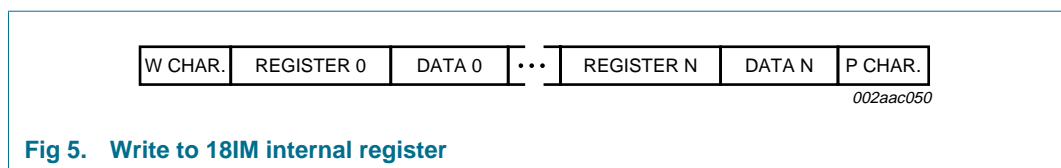

Fig 5. Write to 18IM internal register

Remark: Write and read from the internal 18IM register is processed immediately as soon as the intended register is determined by 18IM.

7.1.4 Read from 18IM internal register

The host issues the internal register read command by sending an R character followed by the registers to be read. The frame is then terminated with a P character.

Once the command is issued, SC18IM700 will access its internal registers and returns the contents of these registers to the host.

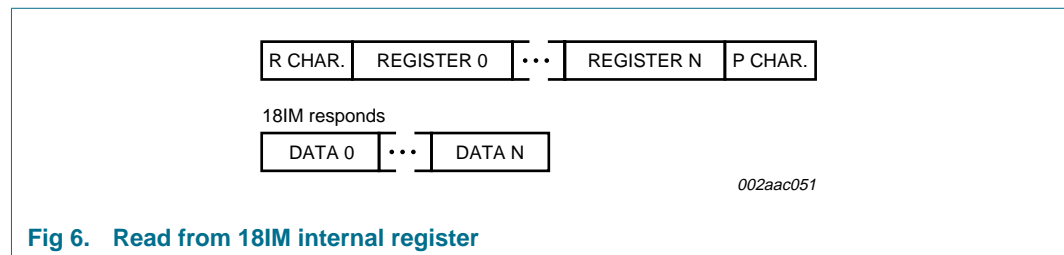

Fig 6. Read from 18IM internal register

7.1.5 Write to GPIO port

The host issues the output port write command by sending an O character followed by the data to be written to the output port. This command enables the host to quickly set any GPIO pins programmed as output without having to write to the SC18IM700 internal IOState register.

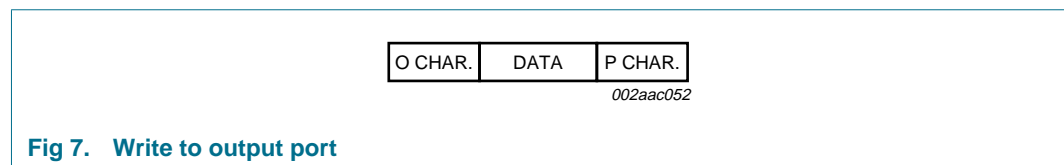

Fig 7. Write to output port

7.1.6 Read from GPIO port

The host issues the input port read command by sending an I character. This command enables the host to quickly read any GPIO pins programmed as input without having to read the SC18IM700 internal IOState register.

Once the command is issued, SC18IM700 will read its internal IOState register and returns its content to the host.

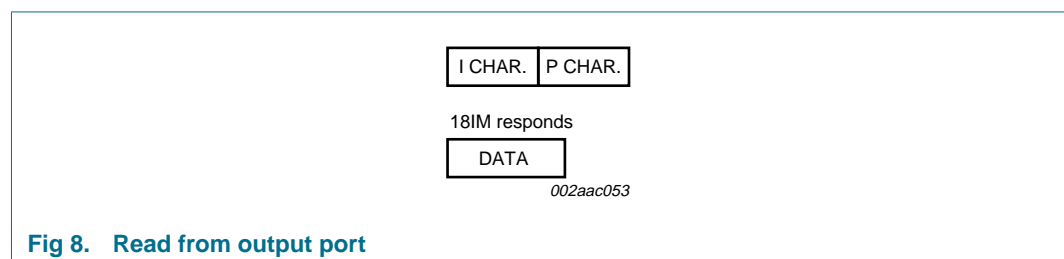

Fig 8. Read from output port

7.1.7 Repeated START: read after write

The SC18IM700 also supports 'read after write' command as specified in the Philips' I²C-bus specification. This allows a read command to be sent after a write command without having to issue a STOP condition between the two commands.

The host issues a write command as normal, then immediately issues a read command without sending a STOP (P) character after the write command.

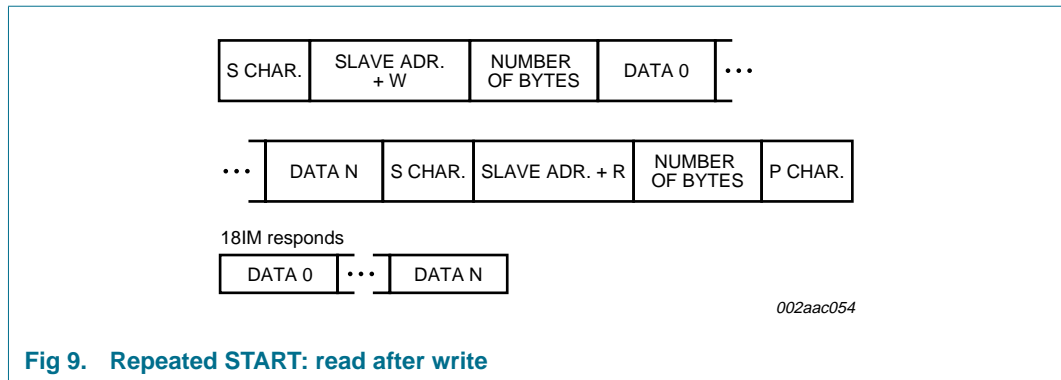

Fig 9. Repeated START: read after write

7.1.8 Repeated START: write after write

The SC18IM700 also supports ‘write after write’ command as specified in the Philips’ I²C-bus specification. This allows a write command to be sent after a write command without having to issue a STOP condition between the two commands.

The host issues a write command as normal, then immediately issues a second write command without sending a STOP (P) character after the first write command.

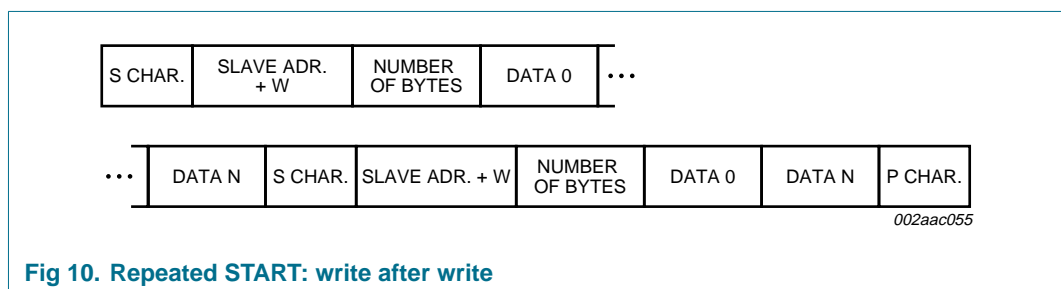

Fig 10. Repeated START: write after write

7.1.9 Power-down mode

The SC18IM700 can be placed in a low-power mode. In this mode the internal oscillator is stopped and SC18IM700 will no longer respond to the host messages. Enter the Power-down mode by sending the power-down character Z (0x5A) followed by the two defined bytes, which are 0x5A and followed by 0xA5. If the exact message is not received, the device will not enter the power-down state.

Upon entering the power-down state, SC18IM700 places the $\overline{\text{WAKEUP}}$ pin in a HIGH state. To have the device leave the power-down state, the $\overline{\text{WAKEUP}}$ pin should be brought LOW. A 1 k Ω resistor must be connected between the $\overline{\text{WAKEUP}}$ pin and V_{DD}.

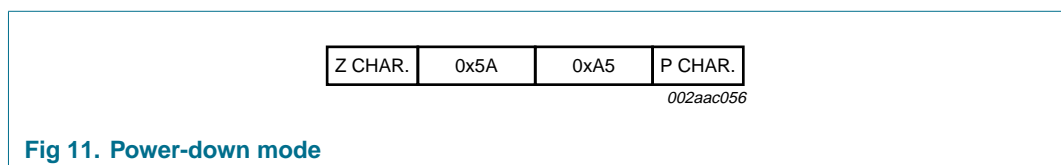

Fig 11. Power-down mode

8. I²C-bus serial interface

The I²C-bus uses two wires (SDA and SCL) to transfer information between devices connected to the bus, and it has the following features:

- Bidirectional data transfer between masters and slaves
- Multi-master bus (no central master)
- Arbitration between simultaneously transmitting masters without corruption of serial data on the bus
- Serial clock synchronization allows devices with different bit rates to communicate via one serial bus
- Serial clock synchronization can be used as a handshake mechanism to suspend and resume serial transfer.

A typical I²C-bus configuration is shown in [Figure 12](#). The SC18IM700 device provides a byte-oriented I²C-bus interface that supports data transfers up to 400 kHz.

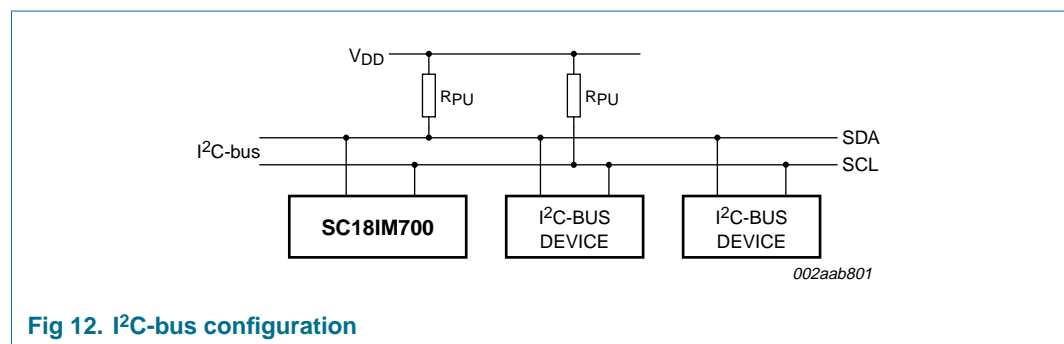

Fig 12. I²C-bus configuration

9. Internal registers available

9.1 Register summary

Table 4: Internal registers summary

Register address	Register	Bit 7	Bit 6	Bit 5	Bit 4	Bit 3	Bit 2	Bit 1	Bit 0	R/W
General register set										
0x00	BRG0	bit 7	bit 6	bit 5	bit 4	bit 3	bit 2	bit 1	bit 0	R/W
0x01	BRG1	bit 7	bit 6	bit 5	bit 4	bit 3	bit 2	bit 1	bit 0	R/W
0x02	PortConf1	GPIO3.1	GPIO3.0	GPIO2.1	GPIO2.0	GPIO1.1	GPIO1.0	GPIO0.1	GPIO0.0	R/W
0x03	PortConf2	GPIO7.1	GPIO7.0	GPIO6.1	GPIO6.0	GPIO5.1	GPIO5.0	GPIO4.1	GPIO4.0	R/W
0x04	IOState	GPIO7	GPIO6	GPIO5	GPIO4	GPIO3	GPIO2	GPIO1	GPIO0	R/W
0x05	reserved	bit 7	bit 6	bit 5	bit 4	bit 3	bit 2	bit 1	bit 0	-
0x06	I2CAdr	bit 7	bit 6	bit 5	bit 4	bit 3	bit 2	bit 1	bit 0	R/W
0x07	I2CCiKL	bit 7	bit 6	bit 5	bit 4	bit 3	bit 2	bit 1	bit 0	R/W
0x08	I2CCiKH	bit 7	bit 6	bit 5	bit 4	bit 3	bit 2	bit 1	bit 0	R/W
0x09	I2CTO	TO7	TO6	TO5	TO4	TO3	TO2	TO1	TE	R/W
0x0A	I2CStat	1	1	1	1	I2CStat[3]	I2CStat[2]	I2CStat[1]	I2CStat[0]	R

9.2 Register descriptions

9.2.1 Baud Rate Generator (BRG)

The baud rate generator is an 8-bit counter that generates the data rate for the transmitter and the receiver. The rate is programmed through the BRG register and the baud rate can be calculated as follows:

$$\text{Baud rate} = \frac{7.3728 \times 10^6}{16 + (\text{BRG1}, \text{BRG0})}$$

Remark: To calculate the baud rate the values in the BRG registers must first be converted from hex to decimal.

Remark: For the new baud rate to take effect, both BRG0 and BRG1 must be written in sequence (BRG0, BRG1) with new values. The new baud rate will be in effect once BRG1 is written.

9.2.2 Programmable port configuration (PortConf1 and PortConf2)

GPIO port 0 to port 7 may be configured by software to one of four types. These are: quasi-bidirectional, push-pull, open-drain, and input-only. Two bits are used to select the desired configuration for each port pin. PortConf1 is used to select the configuration for GPIO3 to GPIO0, and PortConf2 is used to select the configuration for GPIO7 to GPIO4. A port pin has Schmitt triggered input that also has a glitch suppression circuit.

Table 5: Port configurations

GPIOx.1	GPIOx.0	Port configuration
0	0	quasi-bidirectional output configuration
0	1	input-only configuration
1	0	push-pull output configuration
1	1	open-drain output configuration

9.2.2.1 Quasi-bidirectional output configuration

Quasi-bidirectional output type can be used as both an input and output without the need to reconfigure the port. This is possible because when the port outputs a logic HIGH, it is weakly driven, allowing an external device to pull the pin LOW. When the pin is driven LOW, it is driven strongly and able to sink a fairly large current. These features are somewhat similar to an open-drain output except that there are three pull-up transistors in the quasi-bidirectional output that serve different purposes.

The SC18IM700 is a 3 V device, but the pins are 5 V tolerant. In quasi-bidirectional mode, if a user applies 5 V on the pin, there will be a current flowing from the pin to V_{DD}, causing extra power consumption. Therefore, applying 5 V in quasi-bidirectional mode is discouraged.

A quasi-bidirectional port pin has a Schmitt triggered input that also has a glitch suppression circuit.

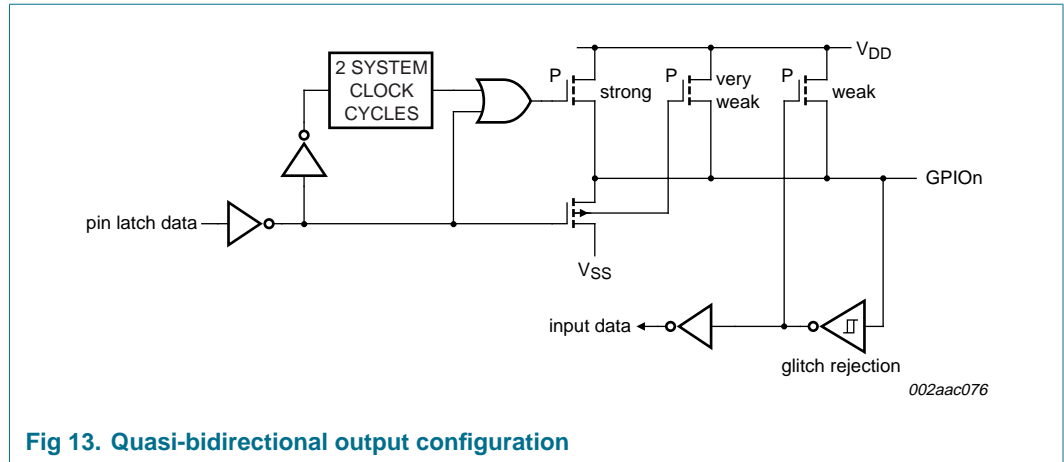

Fig 13. Quasi-bidirectional output configuration

9.2.2.2 Input-only configuration

The input-only port configuration has no output drivers. It is a Schmitt triggered input that also has a glitch suppression circuit.

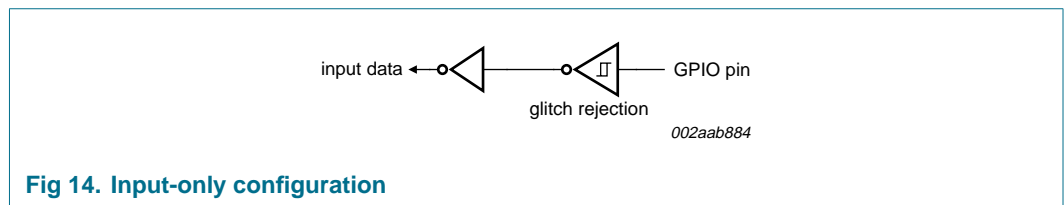

Fig 14. Input-only configuration

9.2.2.3 Push-pull output configuration

The push-pull output configuration has the same pull-down structure as both the open-drain and the quasi-bidirectional output modes, but provides a continuous strong pull-up when the port latch contains a logic 1. The push-pull mode may be used when more source current is needed from a port output. A push-pull port pin has a Schmitt triggered input that also has a glitch suppression circuit.

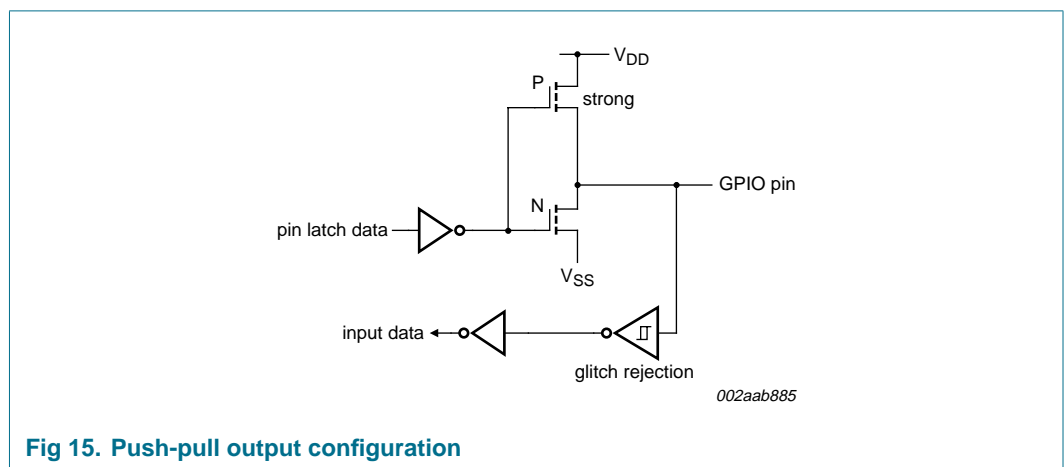

Fig 15. Push-pull output configuration

9.2.2.4 Open-drain output configuration

The open-drain output configuration turns off all pull-ups and only drives the pull-down transistor of the port driver when the port latch contains a logic 0. To be used as a logic output, a port configured in this manner must have an external pull-up, typically a resistor tied to V_{DD}.

An open-drain port pin has a Schmitt triggered input that also has a glitch suppression circuit.

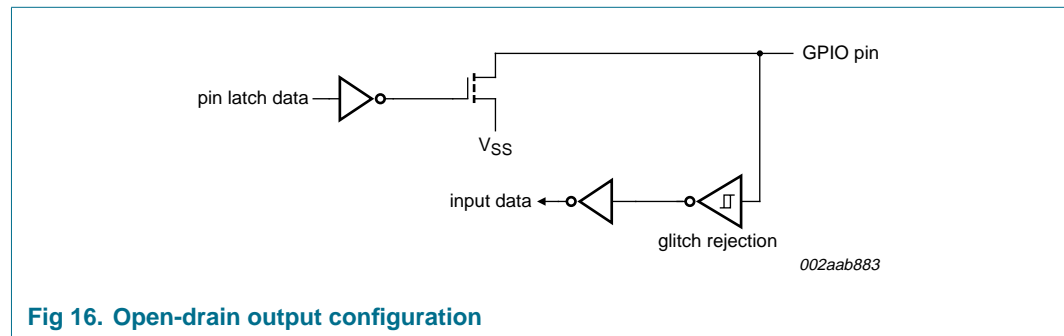

Fig 16. Open-drain output configuration

9.2.3 Programmable I/O pins state register (IOState)

When read, this register returns the actual state of all I/O pins. When written, each register bit will be transferred to the corresponding I/O pin programmed as output.

Table 6: IOState - Programmable I/O pins state register (address 0x04h) bit description

Bit	Symbol	Description
7:0	IOLevel	Set the logic level on the output pins. Write to this register: logic 0 = set output pin to zero logic 1 = set output pin to one Read this register returns states of all pins.

9.2.4 I²C-bus address register (I2CAdr)

The contents of the register represents the device’s own I²C-bus address. The most significant bit corresponds to the first bit received from the I²C-bus after a START condition. A logic 1 in I2CAdr corresponds to a HIGH level on the I²C-bus, and a logic 0 corresponds to a LOW level on the I²C-bus. The least significant bit is not used, but should be programmed with a ‘0’.

I2CAdr is not needed for device operation, but should be configured so that its address does not conflict with an I²C-bus device address used by the bus master.

9.2.5 I²C-bus clock rates (I2CClk)

This register determines the serial clock frequency. The various serial rates are shown in Table 7. The frequency can be determined using the following formula:

$$\text{bit frequency} = \frac{7.3728 \times 10^6}{2 \times (\text{I2CClkH} + \text{I2CCIkL})}$$

I2CCIkH determines the SCL HIGH period, and I2CCIkL determines the SCL LOW period.

Table 7: I²C-bus clock frequency

I2CClk (I2CCIkH + I2CCIkL)	I ² C-bus clock frequency
10 (minimum)	369 kHz
15	246 kHz
25	147 kHz
30	123 kHz
50	74 kHz
60	61 kHz
100	37 kHz

Remark: The numbers used in the formulas are in decimal, but the numbers to program I2CCIkH and I2CCIkL are in hex.

9.2.6 I²C-bus time-out (I2CTO)

The time-out register is used to determine the maximum time that SCL is allowed to be LOW before the I²C-bus state machine is reset.

When the I²C-bus interface is running, I2CTO is loaded after each I²C-bus state transition.

Table 8: I2CTO - I²C-bus time-out register (address 0x09h) bit description

Bit	Symbol	Description
7:1	TO[7:1]	time-out value
0	TE	enable/disable time-out function logic 0 = disable logic 1 = enable

The least significant bit of I2CTO (TE bit) is used as a time-out enable/disable. A logic 1 will enable the time-out function. The time-out period can be calculated as follows:

$$\text{time-out period} = \frac{\text{I2CTO}[7:1] \times 256}{57600} \text{ seconds}$$

The time-out value may vary, and it is an approximate value.

9.2.7 I²C-bus status register (I2CStat)

This register reports the I²C-bus transmit and receive frame status, whether the frame transmits correctly or not.

Table 9: I²C-bus status

Bit 7	Bit 6	Bit 5	Bit 4	Bit 3	Bit 2	Bit 1	Bit 0	I ² C-bus status description
1	1	1	1	0	0	0	0	I2C_OK
1	1	1	1	0	0	0	1	I2C_NACK_ON_ADDRESS
1	1	1	1	0	0	1	0	I2C_NACK_ON_DATA
1	1	1	1	1	0	0	0	I2C_TIME_OUT

10. Limiting values

Table 10: Limiting values

In accordance with the Absolute Maximum Rating System (IEC 60134). [\[1\]](#) [\[2\]](#)

Symbol	Parameter	Conditions	Min	Max	Unit
T _{amb(bias)}	bias ambient temperature		-55	+125	°C
T _{stg}	storage temperature		-65	+150	°C
V _I	input voltage	referenced to V _{SS}	-0.5	+5.5	V
I _{OH(I/O)}	HIGH-level output current per input/output pin				
	GPIO3 to GPIO7		-	20	mA
	all other pins		-	8	mA
I _{OL(I/O)}	LOW-level output current per input/output pin		-	20	mA
I _{I/O(tot)(max)}	maximum total I/O current		-	120	mA
P _{tot/pack}	total power dissipation per package		[3] -	1.5	W

[1] This product includes circuitry specifically designed for the protection of its internal devices from the damaging effects of excessive static charge. Nonetheless, it is suggested that conventional precautions be taken to avoid applying greater than the rated maximum.

[2] Parameters are valid over operating temperature range unless otherwise specified. All voltages are with respect to V_{SS} unless otherwise noted.

[3] Based on package heat transfer, not device power consumption.

11. Static characteristics

Table 11: Static characteristics
 $V_{DD} = 2.4 \text{ V to } 3.6 \text{ V}$; $T_{amb} = -40 \text{ }^\circ\text{C to } +85 \text{ }^\circ\text{C}$; unless otherwise specified.

Symbol	Parameter	Conditions	Min	Typ ^[1]	Max	Unit
I_{DD}	supply current	$V_{DD} = 3.6 \text{ V}$				
		Operating mode; $f = 7.3728 \text{ MHz}$	-	9	15	mA
		Idle mode; $f = 7.3728 \text{ MHz}$	-	3.25	5	mA
		Power-down mode (sleep); GPIO0 to GPIO7 as inputs; inputs at V_{DD}	-	50	70	μA
V_{POR}	power-on reset voltage		-	-	0.2	V
$V_{th(HL)}$	negative-going threshold voltage	except SCL, SDA	$0.22V_{DD}$	$0.4V_{DD}$	-	V
V_{IL}	LOW-level input voltage	SCL, SDA only	-0.5	-	$0.3V_{DD}$	V
$V_{th(LH)}$	positive-going threshold voltage	except SCL, SDA	-	$0.6V_{DD}$	$0.7V_{DD}$	V
V_{IH}	HIGH-level input voltage	SCL, SDA only	$0.7V_{DD}$	-	5.5	V
V_{OL}	LOW-level output voltage	$I_{OL} = 20 \text{ mA}$	^[2] -	0.6	1.0	V
		$I_{OL} = 3.2 \text{ mA}$	^[2] -	0.2	0.3	V
V_{OH}	HIGH-level output voltage	$I_{OH} = -20 \text{ mA}$; Push-pull mode; GPIO3 to GPIO7	$0.8V_{DD}$	-	-	V
		$I_{OH} = -3.2 \text{ mA}$; Push-pull mode; GPIO0 to GPIO2	$V_{DD} - 0.7$	$V_{DD} - 0.4$	-	V
		$I_{OH} = -20 \text{ mA}$; quasi-bidirectional mode; all GPIOs	$V_{DD} - 0.3$	$V_{DD} - 0.2$	-	V
C_{io}	input/output capacitance		^[3] -	-	15	pF
I_{IL}	LOW-level input current	logical 0; all ports; $V_I = 0.4 \text{ V}$	^[4] -	-	-80	μA
I_{LI}	input leakage current	all ports; $V_I = V_{IL}$ or V_{IH}	^[5] -	-	-10	μA
$I_{T(HL)}$	negative-going transition current	logical 1-to-0; all ports; $V_I = 2.0 \text{ V}$ at $V_{DD} = 3.6 \text{ V}$	^[6] ^[7] -30	-	-450	μA
$R_{RESET_N(int)}$	internal pull-up resistance on pin RESET		10	-	30	k Ω

- [1] Typical ratings are not guaranteed. The values listed are at room temperature, 3 V.
- [2] See [Table 10 "Limiting values"](#) for steady state (non-transient) limits on I_{OL} or I_{OH} . If I_{OL}/I_{OH} exceeds the test condition, V_{OL}/V_{OH} may exceed the related specification.
- [3] Pin capacitance is characterized but not tested.
- [4] Measured with GPIO in quasi-bidirectional mode.
- [5] Measured with GPIO in high-impedance mode.
- [6] GPIO in quasi-bidirectional mode with weak pull-up (applies to all GPIO pins with pull-ups). Does not apply to open-drain pins.
- [7] GPIO pins source a transition current when used in quasi-bidirectional mode and externally driven from logic 1 to logic 0. This current is highest when V_I is approximately 2 V.

12. Dynamic characteristics

Table 12: I²C-bus timing characteristics

All the timing limits are valid within the operating supply voltage and ambient temperature range; $V_{DD} = 2.4\text{ V to }3.6\text{ V}$; $T_{amb} = -40\text{ }^{\circ}\text{C to }+85\text{ }^{\circ}\text{C}$; and refer to V_{IL} and V_{IH} with an input voltage of V_{SS} to V_{DD} .

Symbol	Parameter	Conditions	Standard mode I ² C-bus		Fast mode I ² C-bus		Unit
			Min	Max	Min	Max	
f_{SCL}	SCL clock frequency		0	100	0	400	kHz
t_{BUF}	bus free time between a STOP and START condition		4.7	-	1.3	-	μs
$t_{HD;STA}$	hold time (repeated) START condition		4.0	-	0.6	-	μs
$t_{SU;STA}$	set-up time for a repeated START condition		4.7	-	0.6	-	μs
$t_{SU;STO}$	set-up time for STOP condition		4.0	-	0.6	-	μs
$t_{HD;DAT}$	data hold time		0	-	0	-	ns
$t_{VD;ACK}$	data valid acknowledge time		-	0.6	-	0.6	μs
$t_{VD;DAT}$	data valid time	LOW-level	-	0.6	-	0.6	μs
		HIGH-level	-	0.6	-	0.6	μs
$t_{SU;DAT}$	data set-up time		250	-	100	-	ns
t_{LOW}	LOW period of the SCL clock		4.7	-	1.3	-	μs
t_{HIGH}	HIGH period of the SCL clock		4.0	-	0.6	-	μs
t_f	fall time of both SDA and SCL signals		-	0.3	-	0.3	μs
t_r	rise time of both SDA and SCL signals		-	1	-	0.3	μs
t_{SP}	pulse width of spikes that must be suppressed by the input filter		-	50	-	50	ns

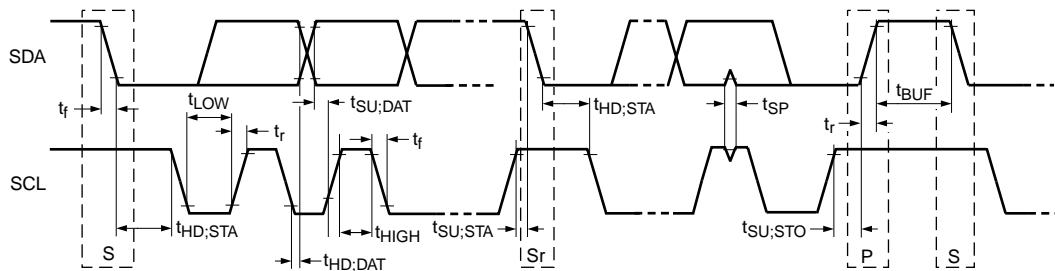

Fig 17. I²C-bus timing

13. Package outline

TSSOP16: plastic thin shrink small outline package; 16 leads; body width 4.4 mm

SOT403-1

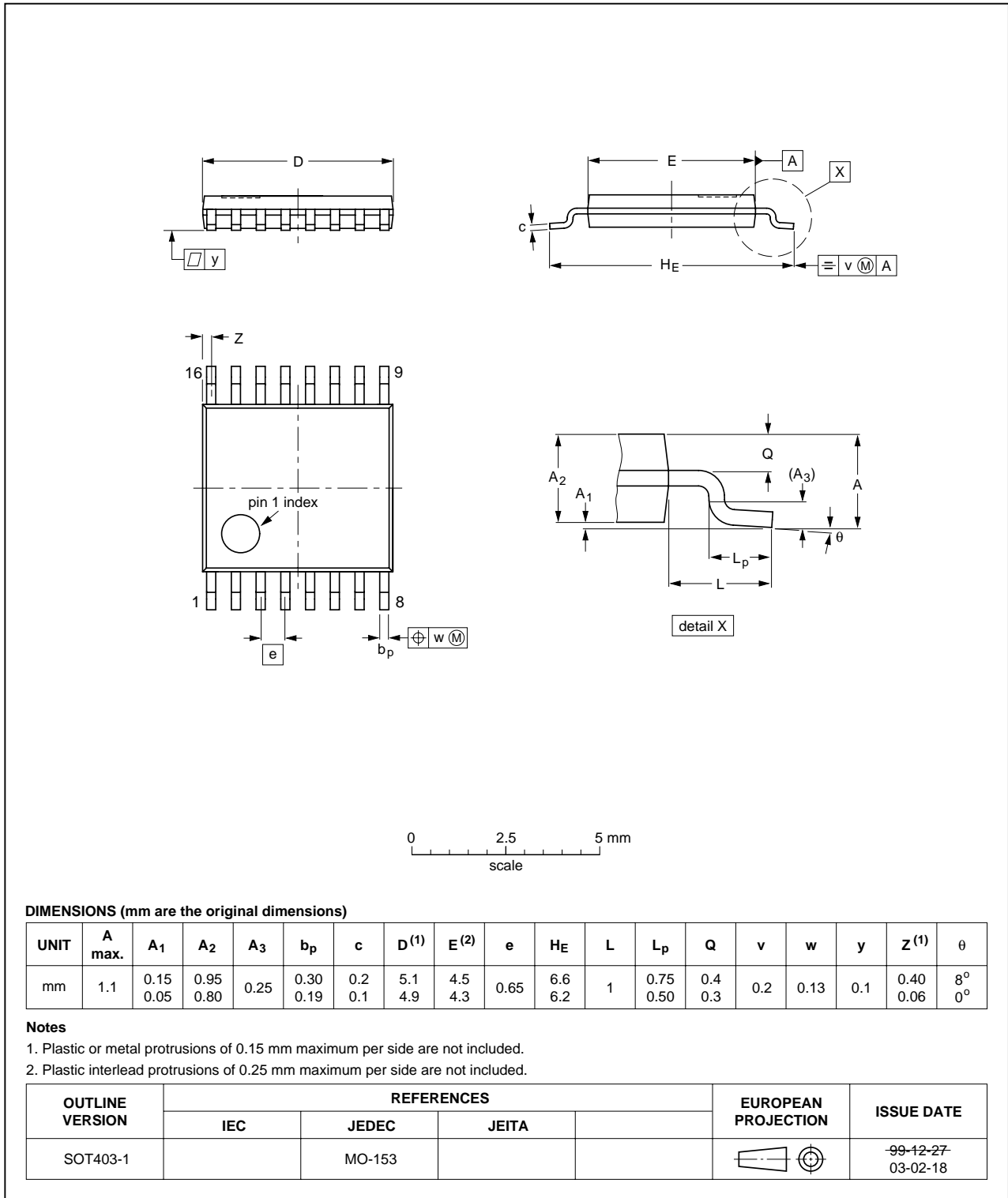

Fig 18. Package outline SOT403-1 (TSSOP16)

14. Soldering

14.1 Introduction to soldering surface mount packages

This text gives a very brief insight to a complex technology. A more in-depth account of soldering ICs can be found in our *Data Handbook IC26; Integrated Circuit Packages* (document order number 9398 652 90011).

There is no soldering method that is ideal for all surface mount IC packages. Wave soldering can still be used for certain surface mount ICs, but it is not suitable for fine pitch SMDs. In these situations reflow soldering is recommended.

14.2 Reflow soldering

Reflow soldering requires solder paste (a suspension of fine solder particles, flux and binding agent) to be applied to the printed-circuit board by screen printing, stencilling or pressure-syringe dispensing before package placement. Driven by legislation and environmental forces the worldwide use of lead-free solder pastes is increasing.

Several methods exist for reflowing; for example, convection or convection/infrared heating in a conveyor type oven. Throughput times (preheating, soldering and cooling) vary between 100 seconds and 200 seconds depending on heating method.

Typical reflow peak temperatures range from 215 °C to 270 °C depending on solder paste material. The top-surface temperature of the packages should preferably be kept:

- below 225 °C (SnPb process) or below 245 °C (Pb-free process)
 - for all BGA, HTSSON..T and SSOP..T packages
 - for packages with a thickness ≥ 2.5 mm
 - for packages with a thickness < 2.5 mm and a volume ≥ 350 mm³ so called thick/large packages.
- below 240 °C (SnPb process) or below 260 °C (Pb-free process) for packages with a thickness < 2.5 mm and a volume < 350 mm³ so called small/thin packages.

Moisture sensitivity precautions, as indicated on packing, must be respected at all times.

14.3 Wave soldering

Conventional single wave soldering is not recommended for surface mount devices (SMDs) or printed-circuit boards with a high component density, as solder bridging and non-wetting can present major problems.

To overcome these problems the double-wave soldering method was specifically developed.

If wave soldering is used the following conditions must be observed for optimal results:

- Use a double-wave soldering method comprising a turbulent wave with high upward pressure followed by a smooth laminar wave.
- For packages with leads on two sides and a pitch (e):
 - larger than or equal to 1.27 mm, the footprint longitudinal axis is **preferred** to be parallel to the transport direction of the printed-circuit board;

- smaller than 1.27 mm, the footprint longitudinal axis **must** be parallel to the transport direction of the printed-circuit board.

The footprint must incorporate solder thieves at the downstream end.

- For packages with leads on four sides, the footprint must be placed at a 45° angle to the transport direction of the printed-circuit board. The footprint must incorporate solder thieves downstream and at the side corners.

During placement and before soldering, the package must be fixed with a droplet of adhesive. The adhesive can be applied by screen printing, pin transfer or syringe dispensing. The package can be soldered after the adhesive is cured.

Typical dwell time of the leads in the wave ranges from 3 seconds to 4 seconds at 250 °C or 265 °C, depending on solder material applied, SnPb or Pb-free respectively.

A mildly-activated flux will eliminate the need for removal of corrosive residues in most applications.

14.4 Manual soldering

Fix the component by first soldering two diagonally-opposite end leads. Use a low voltage (24 V or less) soldering iron applied to the flat part of the lead. Contact time must be limited to 10 seconds at up to 300 °C.

When using a dedicated tool, all other leads can be soldered in one operation within 2 seconds to 5 seconds between 270 °C and 320 °C.

14.5 Package related soldering information

Table 13: Suitability of surface mount IC packages for wave and reflow soldering methods

Package [1]	Soldering method	
	Wave	Reflow [2]
BGA, HTSSON..T [3], LBGA, LFBGA, SQFP, SSOP..T [3], TFBGA, VFBGA, XSON	not suitable	suitable
DHVQFN, HBCC, HBGA, HLQFP, HSO, HSOP, HSQFP, HSSON, HTQFP, HTSSOP, HVQFN, HVSON, SMS	not suitable [4]	suitable
PLCC [5], SO, SOJ	suitable	suitable
LQFP, QFP, TQFP	not recommended [5] [6]	suitable
SSOP, TSSOP, VSO, VSSOP	not recommended [7]	suitable
CWQCCN..L [8], PMFP [9], WQCCN..L [8]	not suitable	not suitable

[1] For more detailed information on the BGA packages refer to the *(LF)BGA Application Note (AN01026)*; order a copy from your Philips Semiconductors sales office.

[2] All surface mount (SMD) packages are moisture sensitive. Depending upon the moisture content, the maximum temperature (with respect to time) and body size of the package, there is a risk that internal or external package cracks may occur due to vaporization of the moisture in them (the so called popcorn effect). For details, refer to the Drypack information in the *Data Handbook IC26; Integrated Circuit Packages; Section: Packing Methods*.

[3] These transparent plastic packages are extremely sensitive to reflow soldering conditions and must on no account be processed through more than one soldering cycle or subjected to infrared reflow soldering with peak temperature exceeding 217 °C ± 10 °C measured in the atmosphere of the reflow oven. The package body peak temperature must be kept as low as possible.

- [4] These packages are not suitable for wave soldering. On versions with the heatsink on the bottom side, the solder cannot penetrate between the printed-circuit board and the heatsink. On versions with the heatsink on the top side, the solder might be deposited on the heatsink surface.
- [5] If wave soldering is considered, then the package must be placed at a 45° angle to the solder wave direction. The package footprint must incorporate solder thieves downstream and at the side corners.
- [6] Wave soldering is suitable for LQFP, QFP and TQFP packages with a pitch (e) larger than 0.8 mm; it is definitely not suitable for packages with a pitch (e) equal to or smaller than 0.65 mm.
- [7] Wave soldering is suitable for SSOP, TSSOP, VSO and VSSOP packages with a pitch (e) equal to or larger than 0.65 mm; it is definitely not suitable for packages with a pitch (e) equal to or smaller than 0.5 mm.
- [8] Image sensor packages in principle should not be soldered. They are mounted in sockets or delivered pre-mounted on flex foil. However, the image sensor package can be mounted by the client on a flex foil by using a hot bar soldering process. The appropriate soldering profile can be provided on request.
- [9] Hot bar soldering or manual soldering is suitable for PMFP packages.

15. Abbreviations

Table 14: Abbreviations

Acronym	Description
ASCII	American Standard Code for Information Interchange
FIFO	First In, First Out
GPIO	General Purpose Input/Output
I ² C-bus	Inter Integrated Circuit bus
RXFIFO	Receive FIFO
TXFIFO	Transmit FIFO
UART	Universal Asynchronous Receiver/Transmitter

16. Revision history

Table 15: Revision history

Document ID	Release date	Data sheet status	Change notice	Doc. number	Supersedes
SC18IM700_1	20060228	Product data sheet	-	-	-

17. Data sheet status

Level	Data sheet status ^[1]	Product status ^{[2] [3]}	Definition
I	Objective data	Development	This data sheet contains data from the objective specification for product development. Philips Semiconductors reserves the right to change the specification in any manner without notice.
II	Preliminary data	Qualification	This data sheet contains data from the preliminary specification. Supplementary data will be published at a later date. Philips Semiconductors reserves the right to change the specification without notice, in order to improve the design and supply the best possible product.
III	Product data	Production	This data sheet contains data from the product specification. Philips Semiconductors reserves the right to make changes at any time in order to improve the design, manufacturing and supply. Relevant changes will be communicated via a Customer Product/Process Change Notification (CPCN).

[1] Please consult the most recently issued data sheet before initiating or completing a design.

[2] The product status of the device(s) described in this data sheet may have changed since this data sheet was published. The latest information is available on the Internet at URL <http://www.semiconductors.philips.com>.

[3] For data sheets describing multiple type numbers, the highest-level product status determines the data sheet status.

18. Definitions

Short-form specification — The data in a short-form specification is extracted from a full data sheet with the same type number and title. For detailed information see the relevant data sheet or data handbook.

Limiting values definition — Limiting values given are in accordance with the Absolute Maximum Rating System (IEC 60134). Stress above one or more of the limiting values may cause permanent damage to the device. These are stress ratings only and operation of the device at these or at any other conditions above those given in the Characteristics sections of the specification is not implied. Exposure to limiting values for extended periods may affect device reliability.

Application information — Applications that are described herein for any of these products are for illustrative purposes only. Philips Semiconductors makes no representation or warranty that such applications will be suitable for the specified use without further testing or modification.

19. Disclaimers

Life support — These products are not designed for use in life support appliances, devices, or systems where malfunction of these products can reasonably be expected to result in personal injury. Philips Semiconductors

21. Contact information

For additional information, please visit: <http://www.semiconductors.philips.com>

For sales office addresses, send an email to: sales.addresses@www.semiconductors.philips.com

customers using or selling these products for use in such applications do so at their own risk and agree to fully indemnify Philips Semiconductors for any damages resulting from such application.

Right to make changes — Philips Semiconductors reserves the right to make changes in the products - including circuits, standard cells, and/or software - described or contained herein in order to improve design and/or performance. When the product is in full production (status 'Production'), relevant changes will be communicated via a Customer Product/Process Change Notification (CPCN). Philips Semiconductors assumes no responsibility or liability for the use of any of these products, conveys no license or title under any patent, copyright, or mask work right to these products, and makes no representations or warranties that these products are free from patent, copyright, or mask work right infringement, unless otherwise specified.

20. Trademarks

Notice — All referenced brands, product names, service names and trademarks are the property of their respective owners.

I²C-bus — logo is a trademark of Koninklijke Philips Electronics N.V.

22. Contents

1	General description	1	14.4	Manual soldering	18
2	Features	1	14.5	Package related soldering information	18
3	Applications	1	15	Abbreviations	19
4	Ordering information	2	16	Revision history	19
5	Block diagram	2	17	Data sheet status	20
6	Pinning information	3	18	Definitions	20
6.1	Pinning	3	19	Disclaimers	20
6.2	Pin description	3	20	Trademarks	20
7	Functional description	4	21	Contact information	20
7.1	UART message format	4			
7.1.1	Write N bytes to slave device	4			
7.1.2	Read N byte from slave device	5			
7.1.3	Write to 18IM internal register	5			
7.1.4	Read from 18IM internal register	6			
7.1.5	Write to GPIO port	6			
7.1.6	Read from GPIO port	6			
7.1.7	Repeated START: read after write	6			
7.1.8	Repeated START: write after write	7			
7.1.9	Power-down mode	7			
8	I²C-bus serial interface	8			
9	Internal registers available	8			
9.1	Register summary	8			
9.2	Register descriptions	9			
9.2.1	Baud Rate Generator (BRG)	9			
9.2.2	Programmable port configuration (PortConf1 and PortConf2)	9			
9.2.2.1	Quasi-bidirectional output configuration	9			
9.2.2.2	Input-only configuration	10			
9.2.2.3	Push-pull output configuration	10			
9.2.2.4	Open-drain output configuration	11			
9.2.3	Programmable I/O pins state register (IOState)	11			
9.2.4	I ² C-bus address register (I2CAdr)	11			
9.2.5	I ² C-bus clock rates (I2CCLK)	11			
9.2.6	I ² C-bus time-out (I2CTO)	12			
9.2.7	I ² C-bus status register (I2CStat)	12			
10	Limiting values	13			
11	Static characteristics	14			
12	Dynamic characteristics	15			
13	Package outline	16			
14	Soldering	17			
14.1	Introduction to soldering surface mount packages	17			
14.2	Reflow soldering	17			
14.3	Wave soldering	17			



© Koninklijke Philips Electronics N.V. 2006

All rights are reserved. Reproduction in whole or in part is prohibited without the prior written consent of the copyright owner. The information presented in this document does not form part of any quotation or contract, is believed to be accurate and reliable and may be changed without notice. No liability will be accepted by the publisher for any consequence of its use. Publication thereof does not convey nor imply any license under patent- or other industrial or intellectual property rights.

Date of release: 28 February 2006
Document number: SC18IM700_1

Published in The Netherlands