

## GaAs MMIC SUB-HARMONICALLY PUMPED MIXER, 28 - 40 GHz

### Typical Applications

The HMC259 is ideal for:

- Point to Point Radios
- LMDS
- SATCOM

### Functional Diagram

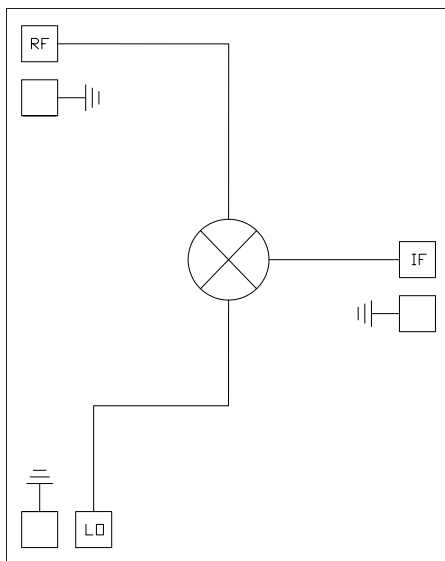

### Features

- Sub-Harmonically Pumped (x2) LO
- High 2LO/RF Isolation: >35 dB
- Small Size: 1.24mm x 1.55mm

### General Description

The HMC259 chip is a broadband sub-harmonically pumped (x2) balanced MMIC passive mixer which can be used as an upconverter or downconverter. The chip utilizes a GaAs MESFET process resulting in a small overall chip area of 1.9mm<sup>2</sup>. This chip has a very wide IF bandwidth of DC-13 GHz. The 2LO to RF isolation is excellent eliminating the need for additional filtering. All data is with the chip in a 50 ohm test fixture connected via 0.025mm (1 mil) diameter wire bonds of minimal length <0.31mm (<12 mils). This device is a much smaller and more reliable replacement to hybrid diode mixer designs.

### Electrical Specifications, $T_A = +25^\circ C$ , LO Drive = +15 dBm

Parameter	IF = 1 GHz			IF = 1 GHz			Units
	Min.	Typ.	Max.	Min.	Typ.	Max.	
Frequency Range, RF	28 - 40			36 - 40			GHz
Frequency Range, LO	14 - 20			18 - 20			GHz
Frequency Range, IF	DC - 12			DC - 4			GHz
Conversion Loss		14	17		12	15	dB
Noise Figure (SSB)		14	17		12	15	dB
2LO to RF Isolation	28	35		40	50		dB
2LO to IF Isolation	58	65		63	68		dB
RF to IF Isolation	25	30		25	32		dB
LO to IF Isolation	10	15		12	17		dB
IP3 (Input)	2	5		2	6		dBm
1 dB Compression (Input)	-7	-4		-7	-1		dBm

\*Unless otherwise noted, all measurements performed as downconverter, IF= 1 GHz.

## GaAs MMIC SUB-HARMONICALLY PUMPED MIXER, 28 - 40 GHz

**Conversion Gain vs. Temperature @ LO = +15 dBm**

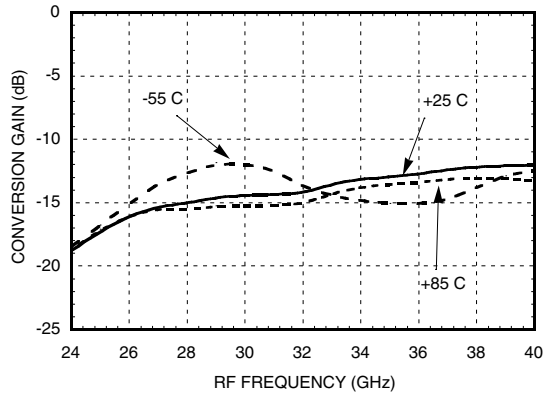

**Isolation @ LO = +15 dBm**

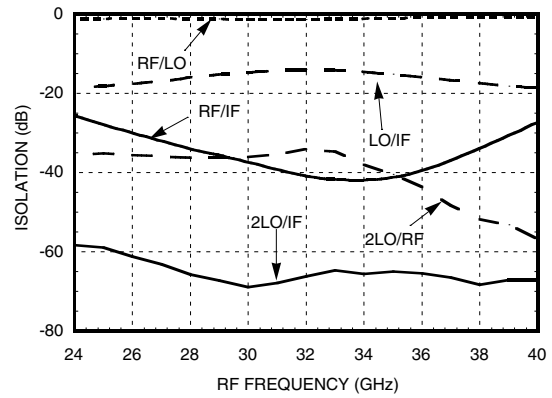

**Conversion Gain vs. LO Drive**

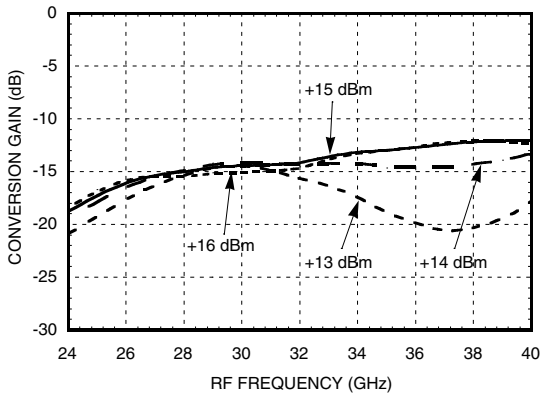

**Return Loss @ LO = +15 dBm**

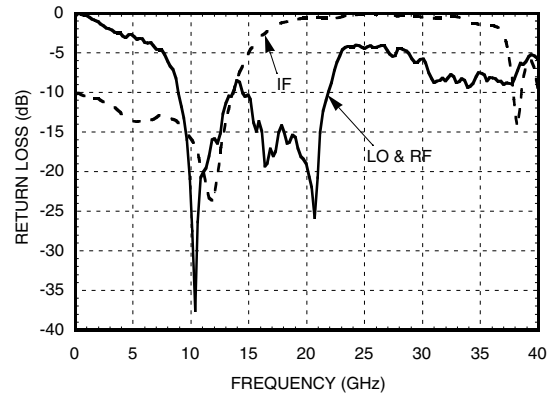

**IF Bandwidth @ LO = +15 dBm**

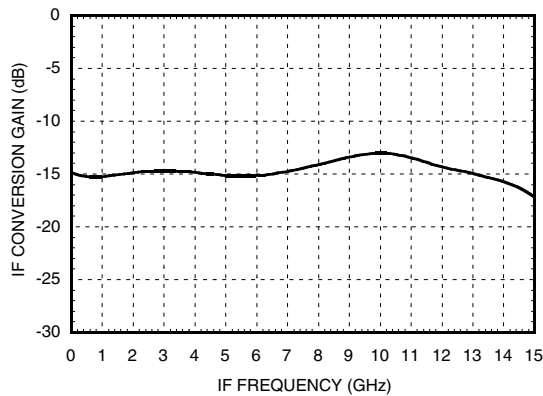

**Upconverter Performance Conversion Gain @ LO = +15 dBm**

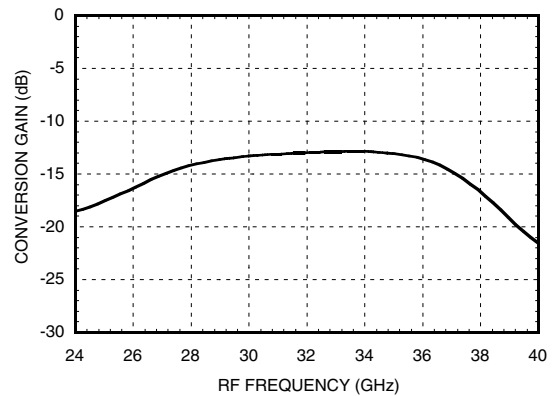

## GaAs MMIC SUB-HARMONICALLY PUMPED MIXER, 28 - 40 GHz

**Input IP3 vs. LO Drive**

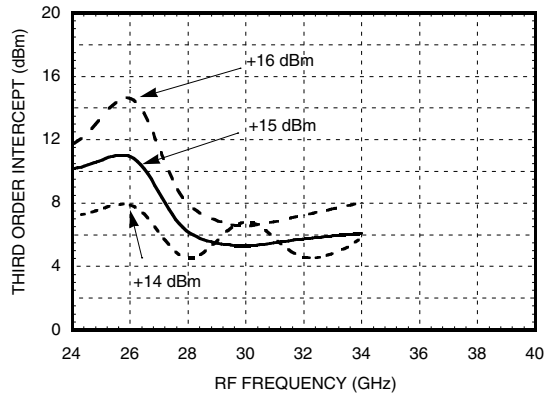

**Input IP3 vs. Temperature @ LO = +15 dBm**

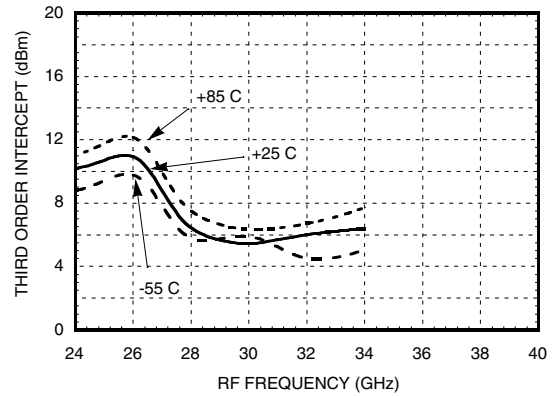

**Input IP2 vs. LO Drive**

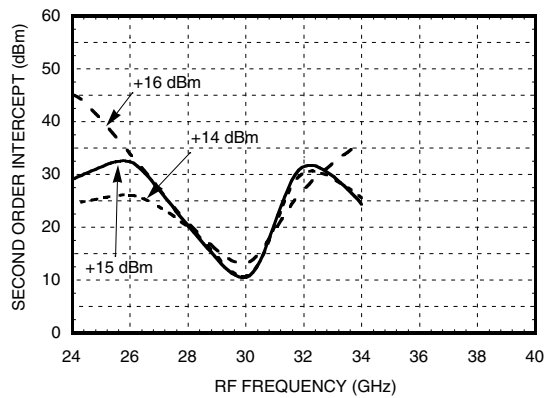

**Input IP2 vs. Temperature @ LO = +15 dBm**

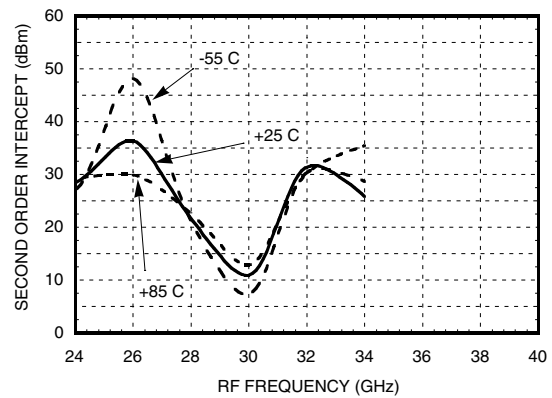

**MxN Spurious Outputs**

mRF	nLO					
	±5	±4	±3	±2	±1	0
-3						
-2	-37					
-1	-46	-48	-22			
0				-28	+29	
1				x	-24	-29
2		-40	-44	-81		
3	-76					

RF = 30 GHz @ -15 dBm  
 LO = 14 GHz @ +15 dBm  
 All values in dBc below the IF power level

**P1dB vs. Temperature @ LO = +15 dBm**

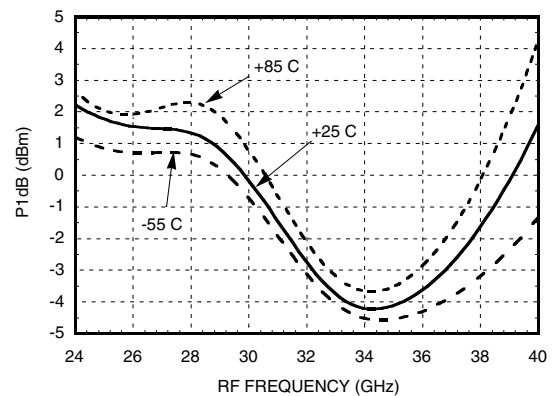

## GaAs MMIC SUB-HARMONICALLY PUMPED MIXER, 28 - 40 GHz

### Absolute Maximum Ratings

RF / IF Input	+13 dBm
LO Drive	+23 dBm
Storage Temperature	-65 to +150 deg C
Operating Temperature	-55 to +85 deg C

### Outline Drawing

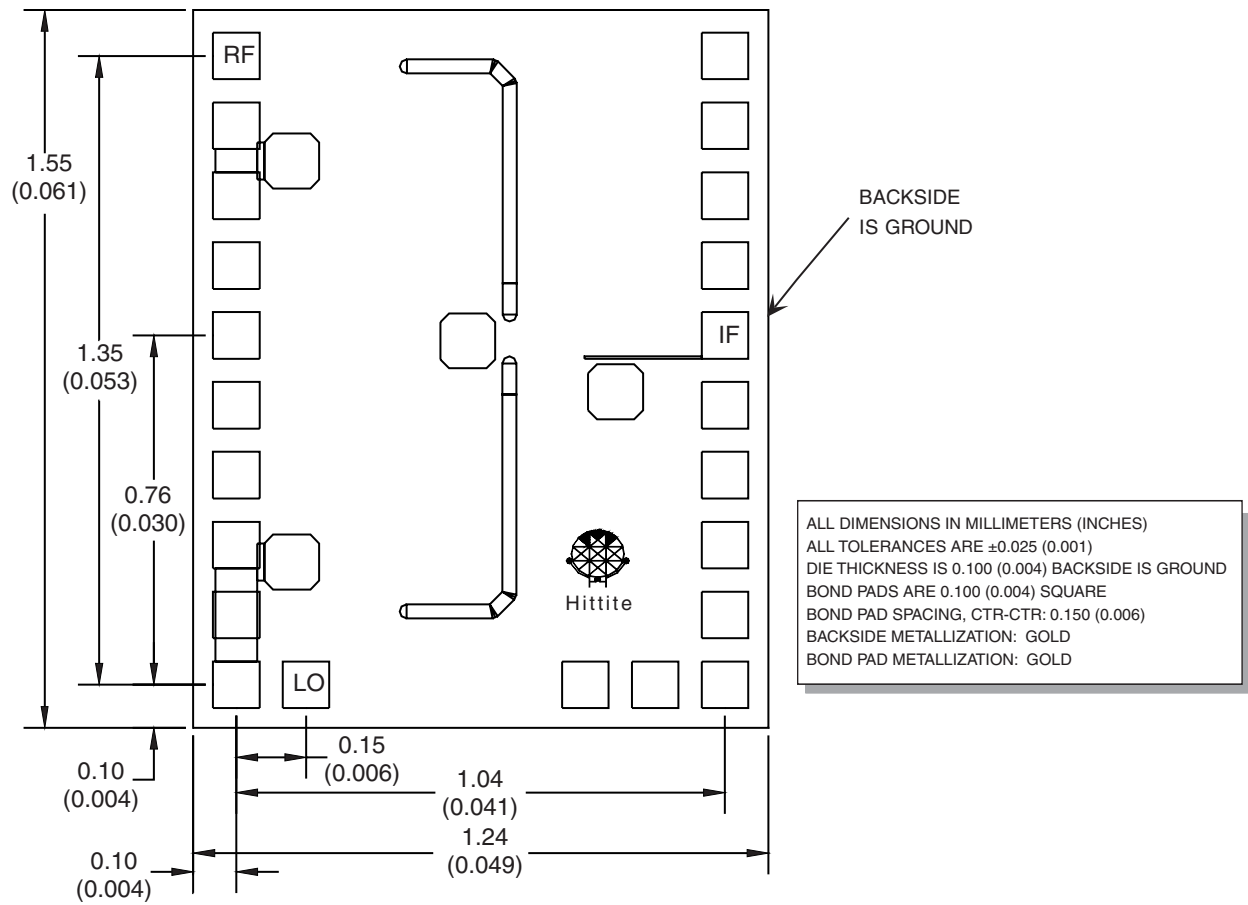

## GaAs MMIC SUB-HARMONICALLY PUMPED MIXER, 28 - 40 GHz

### MMIC Assembly Techniques for HMC259

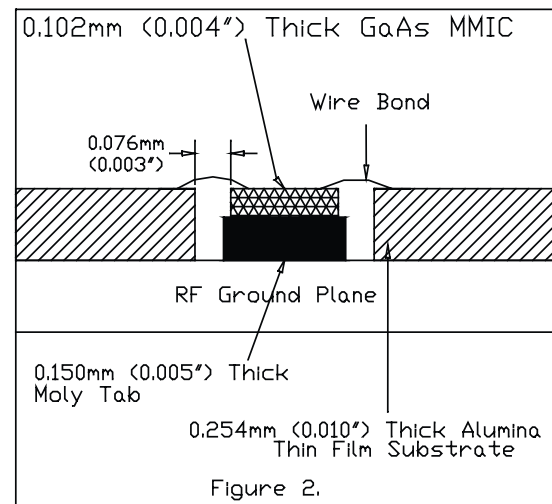
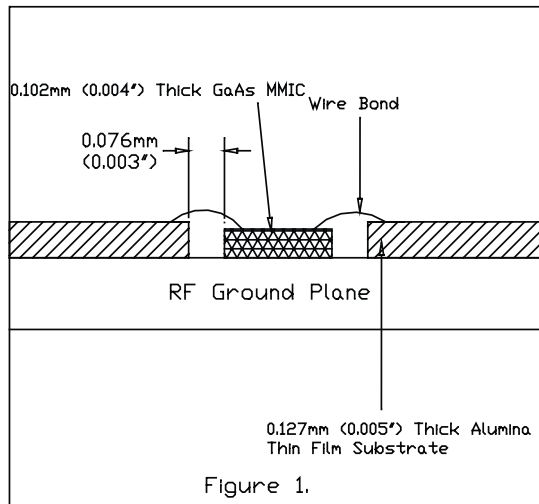

### Mounting & Bonding Techniques for Millimeterwave GaAs MMICs

The die should be attached directly to the ground plane eutectically or with conductive epoxy (see HMC general Handling, Mounting, Bonding Note).

50 Ohm Microstrip transmission lines on 0.127mm (5 mil) thick alumina thin film substrates are recommended for bringing RF to and from the chip (Figure 1). If 0.254mm (10 mil) thick alumina thin film substrates must be used, the die should be raised 0.150mm (6 mils) so that the surface of the die is coplanar with the surface of the substrate. One way to accomplish this is to attach the 0.102mm (4 mil) thick die to a 0.150mm (6 mil) thick molybdenum heat spreader (moly-tab) which is then attached to the ground plane (Figure 2).

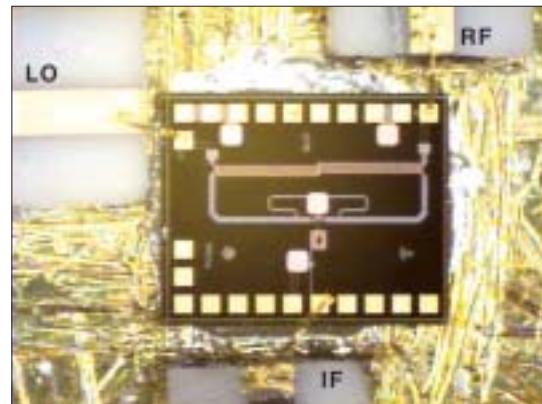

Figure 3: Typical HMC259 Assembly

Microstrip substrates should be brought as close to the die as possible in order to minimize bond wire length. Typical die-to-substrate spacing is 0.076mm (3 mils).

**GaAs MMIC SUB-HARMONICALLY  
PUMPED MIXER, 28 - 40 GHz****Handling Precautions**

Follow these precautions to avoid permanent damage.

**Cleanliness:**

Handle the chips in a clean environment.  
DO NOT attempt to clean the chip using liquid cleaning systems.

**Static Sensitivity:**

Follow ESD precautions to protect against  $> \pm 250V$  ESD strikes.

**Transients:**

Suppress instrument and bias supply transients while bias is applied.  
Use shielded signal and bias cables to minimize inductive pick-up.

**General Handling:**

Handle the chip along the edges with a vacuum collet or with a sharp pair of bent tweezers.  
The surface of the chip has fragile air bridges and should not be touched with vacuum collet, tweezers, or fingers.

**Mounting**

The chip is back-metallized and can be die mounted with AuSn eutectic preforms or with electrically conductive epoxy. The mounting surface should be clean and flat.

**Eutectic Die Attach:**

A 80/20 gold tin preform is recommended with a work surface temperature of 255 deg. C and a tool temperature of 265 deg. C. When hot 90/10 nitrogen/hydrogen gas is applied, tool tip temperature should be 290 deg. C.

DO NOT expose the chip to a temperature greater than 320 deg. C for more than 20 seconds. No more than 3 seconds of scrubbing should be required for attachment.

**Epoxy Die Attach:**

Apply a minimum amount of epoxy to the mounting surface so that a thin epoxy fillet is observed around the perimeter of the chip once it is placed into position.

Cure epoxy per the manufacturer's schedule.

**Wire Bonding**

Ball or wedge bond with 1.0 diameter pure gold wire. Thermosonic wirebonding with a nominal stage temperature of 150 deg. C and a ball bonding force of 40 to 50 grams or wedge bonding force of 18 to 22 grams is recommended. Use the minimum level of ultrasonic energy to achieve reliable wirebonds. Wirebonds should be started on the chip and terminated on the package or substrate. All bonds should be as short as possible  $< 0.31\text{mm}$  (12 mils).