

# QUAD DIFFERENTIAL LINE DRIVER

WITH SEPARATE LOGIC BIAS AND DRIVER BIAS SUPPLIES, AND ENABLE FUNCTION

# ET7272

## FEATURES

- Supply Voltage Range 3.5V to 30V
- Operation to 800KHz
- CMOS and TTL Compatible Inputs
- Separate logic bias and driver supply pins
- Optional single supply operation for moderate power applications
- High Impedance Buffered Inputs with Hysteresis may be driven directly by phototransistors
- Tri-State outputs
- 80mA peak SINK/SOURCE current
- Outputs Protected by Thermal Shut-Down

## APPLICATIONS

- Optical Encoders
- Industrial Controls

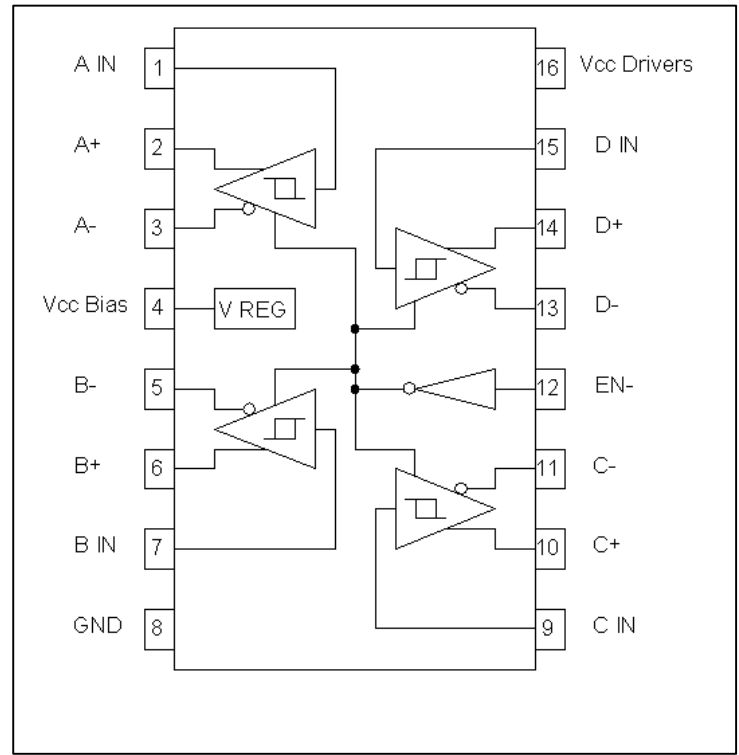

## DESCRIPTION

These line drivers are pin compatible with 26LS31 in applications where pin 4 = 5V and pin 12 = GND. Internal clamp diodes allow trouble-free operation when driving cable lengths exceeding 100m. Split supplies are provided to minimize standby power dissipation in high voltage applications. The logic should be powered from a regulated 5V supply at the VccBias pin. The output stages may then be powered by a separate supply at VccDrivers, up to 30V. Output voltage swings of 0.3V to VCC-1.9V are typical. The outputs are protected against shorts to ground, shorts to Vcc and to other outputs, by a two-fold scheme of current limiting and thermal shutdown. This assures highly reliable operation in harsh environments. Heat-sinking may be accomplished at pin 8 which is directly connected to the ASIC substrate.

## ABSOLUTE MAXIMUM RATINGS

Parameter	Symbol	Min.	Max.	Units	Ref.
Operating Temperature Range	$T_A$	-55	115	°C	
Supply Voltage Range(both)	$V_{CC}$	4.5	30	V	

ETIC RESERVES THE RIGHT TO MAKE CHANGES AT ANY TIME TO IMPROVE THE DESIGN AND TO SUPPLY THE BEST PRODUCT.

©2000, Rev A1

iC-Haus GmbH

Integrated Circuits

Am Kuemmerling 18, D-55294 Bodenheim

Tel +49-6135-9292-0

Fax +49-6135-9292-192

<http://www.ichaus.com>

## ELECTRICAL CHARACTERISTICS

Unless otherwise specified,  $T_A = 25^\circ\text{C}$  and  $EN < 0.8\text{V}$ .

Parameters	Symbol	Min.	Typ.	Max.	Units	Test Conditions
Overtemp Operate Point (junction) <sup>1</sup>	$T_{JOP}$		172		$^\circ\text{C}$	
Overtemp Release Point (junction) <sup>1</sup>	$T_{JRP}$		136		$^\circ\text{C}$	
Vcc Bias Voltage Range	$V_{CCB}$	3.5	5	30	V	
Vcc Drivers Voltage Range	$V_{CCD}$	4.5	5	30	V	
Supply Current $V_{CCB1}$ (BIAS)	$I_{CCB1}$		11.9	16.0	mA	$V_{CCB}$ and $V_{CCD} = 5\text{V}$
Supply Current $V_{CCD1}$ (DRIVERS)	$I_{CCD1}$		2.4	3.3	mA	$V_{CCB}$ and $V_{CCD} = 5\text{V}$
Supply Current $V_{CCB2}$	$I_{CCB2}$		2.5	3.4	mA	$V_{CCB}$ and $V_{CCD} = 5\text{V}$ , $EN > 2\text{V}$
Supply Current $V_{CCD2}$	$I_{CCD2}$		0.0	0.1	mA	$V_{CCB}$ and $V_{CCD} = 5\text{V}$ , $EN > 2\text{V}$
Supply Current $V_{CCB3}$	$I_{CCB3}$		12.1	18.5	mA	$V_{CCB}$ and $V_{CCD} = 30\text{V}$
Supply Current $V_{CCD3}$	$I_{CCD3}$		2.4	3.3	mA	$V_{CCB}$ and $V_{CCD} = 30\text{V}$
Supply Current $V_{CCB4}$	$I_{CCB4}$		2.6	3.5	mA	$V_{CCB}$ and $V_{CCD} = 5\text{V}$ , $EN > 2\text{V}$
Supply Current $V_{CCD4}$	$I_{CCD4}$		0.0	0.1	mA	$V_{CCB}$ and $V_{CCD} = 5\text{V}$ , $EN > 2\text{V}$
Enable Input Threshold	$V_{THE}$	0.8	1.5	2	V	
Enable Low Level Input Current	$I_{ILE}$	-10	0	10	$\mu\text{A}$	$V_{IN} = 0\text{V}$ , $V_{CCB} = 5\text{V}$
Enable High Level Input Current	$I_{IHE}$	-	108	150	$\mu\text{A}$	$V_{IN} = 5\text{V}$ , $V_{CCB} = 5\text{V}$
High Impedance Output Leakage	$I_{OZ}$	-4.0	0.0	4.0	$\mu\text{A}$	$V_{CCD} = 30\text{V}$ , $EN > 2\text{V}$ , Output at 15V
Input Positive-Going Threshold	$V_{T+}$	1.05	1.25	1.45	V	$V_{CCB} = 5\text{V}$
Input Negative-Going Threshold	$V_{T-}$	0.75	0.95	1.15	V	$V_{CCB} = 5\text{V}$
Input Hysteresis	$V_H$	-	0.3	-	V	$V_{CCB} = 5\text{V}$
Low Level Input Current	$I_{IL}$		-0.1	-4.0	$\mu\text{A}$	$V_{IN} = 0\text{V}$ , $V_{CCB} = 5\text{V}$
High Level Input Current	$I_{IH}$		0	4.0	$\mu\text{A}$	$V_{IN} = 5\text{V}$ , $V_{CCB} = 5\text{V}$
Low Level Output1	$V_{OL1}$		375	500	mV	$I_{OL} = 20\text{mA}$ , $V_{CCD} = 5\text{V}$
Low Level Output2	$V_{OL2}$		370	500	mV	$I_{OL} = 20\text{mA}$ , $V_{CCD} = 30\text{V}$
High Level Output1	$V_{OH1}$	2.4	2.8		V	$I_{OH} = -20\text{mA}$ , $V_{CCD} = 5\text{V}$
High Level Output2	$V_{OH2}$	27.7	28.1		V	$I_{OH} = -20\text{mA}$ , $V_{CCD} = 30\text{V}$

ETIC RESERVES THE RIGHT TO MAKE CHANGES AT ANY TIME TO IMPROVE THE DESIGN AND TO SUPPLY THE BEST PRODUCT.

©2000, Rev A1

iC-Haus GmbH

Integrated Circuits

Am Kuemmerling 18, D-55294 Bodenheim

Tel +49-6135-9292-0

Fax +49-6135-9292-192

<http://www.ichaus.com>

## AC SWITCHING CHARACTERISTICS

Values given at  $V_{CCB} = 5V$ ,  $V_{CCD} = 24V$ ,  $T_A = 25^\circ C$ ,  $C_L = 1000pF$  on all outputs, and  $EN < 0.8V$ .

Parameters	Symbol	Min.	Typ.	Max	Units	Test Conditions
Propagation delay, rising input 50% point to zero crossing of differential outputs	$T_{PLH}$		450	630	ns	
Propagation delay, falling input 50% point to zero crossing of differential outputs	$T_{PHL}$		450	630	ns	
Output Rise Time	$T_R$		700	980	ns	
Output Fall Time	$T_F$		700	980	ns	

### NOTES:

1. This is not a test parameter, but for information only.
2. It may be necessary to clamp the outputs with Schottky diodes when driving extremely long cables with high capacitance between outputs. These diodes should have a forward voltage of less than 0.4V, and be connected with cathode to the output and anode to ground.

### PACKAGE

Chip Only  
16 Lead SOIC

### SUFFIX

-C  
-SOP

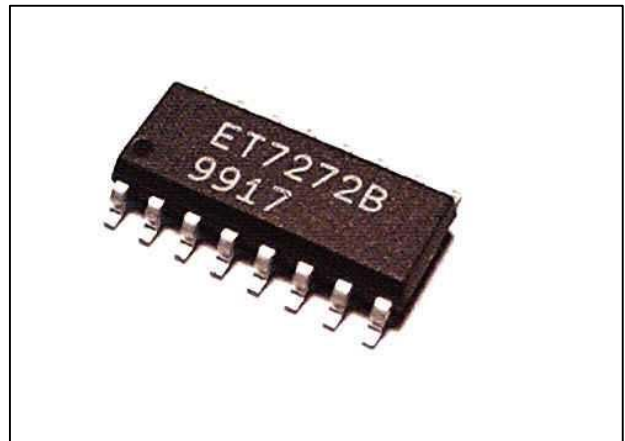

ETIC RESERVES THE RIGHT TO MAKE CHANGES AT ANY TIME TO IMPROVE THE DESIGN AND TO SUPPLY THE BEST PRODUCT.

©2000, Rev A1

iC-Haus GmbH  
Integrated Circuits

Am Kuemmerling 18, D-55294 Bodenheim

Tel +49-6135-9292-0  
Fax +49-6135-9292-192  
<http://www.ichaus.com>