

**D**

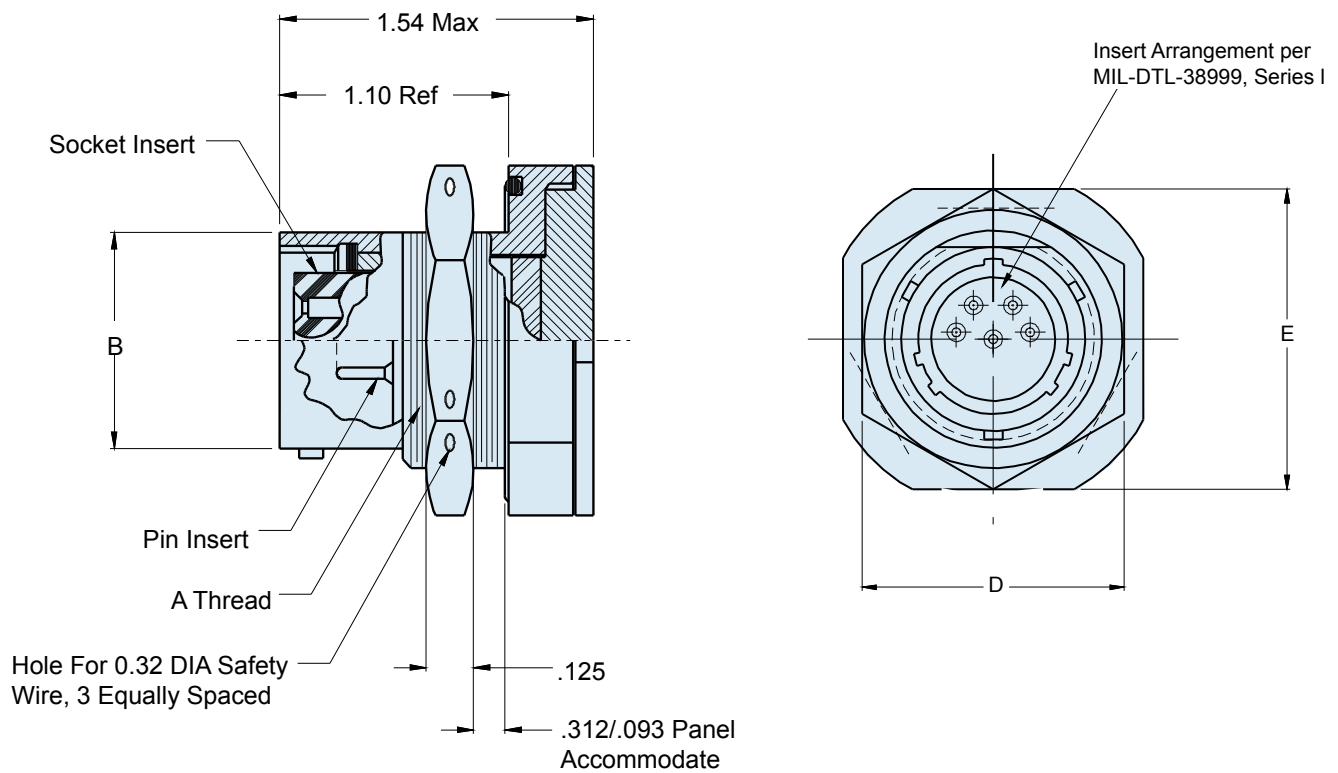

947-050  
Jam Nut Mount Shorting Receptacle  
MIL-DTL-38999 Series I Type



TABLE I: CONNECTOR DIMENSIONS

SHELL SIZE	A THREAD CLASS 2A	B DIA MAX	D HEX	E FLATS	F DIA ±.005(0.1)	G +.000-.005 (0-0.1)
09	11/16-24 UNEF	.573(14.6)	.875(22.2)	1.062(27.0)	.703(17.9)	.699(17.8)
11	13/16-20 UNEF	.701(17.8)	1.000(25.4)	1.250(31.8)	.827(21.0)	.769(19.5)
13	1 -20 UNEF	.851(21.6)	1.188(30.2)	1.375(34.9)	1.015(25.8)	.955(24.3)
15	1 1/8-18 UNEF	.976(24.8)	1.312(33.3)	1.500(38.1)	1.140(29.0)	1.084(27.5)
17	1 1/4-18 UNEF	1.101(28.0)	1.438(36.5)	1.625(41.3)	1.265(32.1)	1.208(30.7)
19	1 3/8-18 UNEF	1.208(30.7)	1.562(39.7)	1.812(46.0)	1.390(35.3)	1.333(33.9)
21	1 1/2-18 UNEF	1.333(33.9)	1.688(42.9)	1.938(49.2)	1.515(38.5)	1.459(37.1)
23	1 5/8-18 UNEF	1.458(37.0)	1.812(46.0)	2.062(52.4)	1.640(41.7)	1.580(40.1)
25	1 3/4-18 UNS	1.583(40.2)	2.000(50.8)	2.188(55.6)	1.765(44.8)	1.709(43.4)

TABLE II: FINISH

SYM	MATERIAL	FINISH
A	Aluminum	Cadmium Plate/Bright Dip
B		Cadmium Plate/Olive Drab
E		Gold Iridite
J		Gold Iridite over Cadmium Plate over Nickel Plate
L		Cadmium Plate/Olive Drab over Nickel Plate (500-Hour Salt Spray)
M		Electroless Nickel
N		Cadmium Plate/Olive Drab over Nickel Plate
NF		Cadmium Plate/Olive Drab over Nickel Plate (500 Hour Salt Spray)
P		Nickel Plate
T		Cadmium Plate over Nickel Plate
W		Leached Iridite
Y		Gold Iridite over Cadmium Plate
Z		Special per Purchase Order

\*Consult Factory for Additional Plating Options

APPLICATION NOTES

- Assembly identified with manufacturer's name and part number, space permitting.
- Material/finish:  
Shell assembly, jam nut, locking coupling nut—aluminum alloy/  
see Table II  
Contacts—copper alloy/gold plate
- Insulators—high grade dielectric/N.A.  
Bayonet pins—CRES/passivate  
Ground wafer—copper/tin plate  
Conductive seal—Consil II/N.A.  
Metric Dimensions (mm) are indicated in parentheses.

