

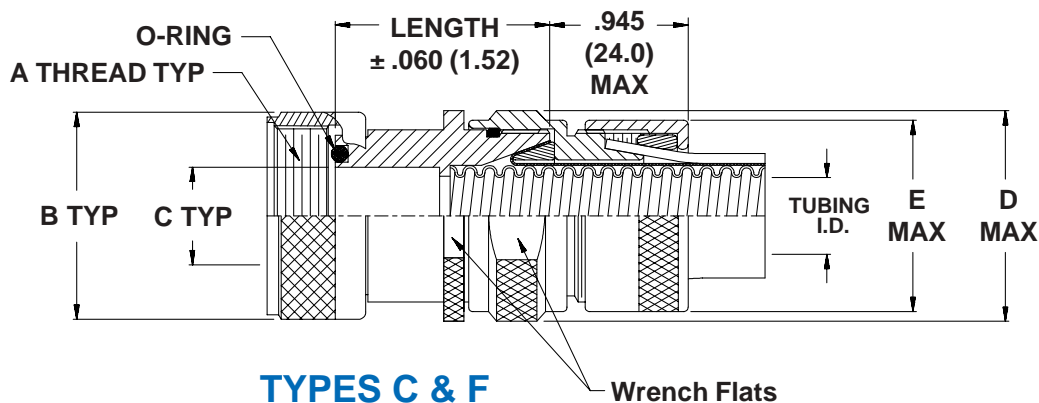

712-380 - Types B, C, D, E, F & G User-Installable Bulkhead Fitting for Series 74 Helical Convuluted Tubing

TYPES B, C, D, E, F, & G BULKHEAD

TO BE USED
WITH
ADAPTERS AND
TRANSITIONS
SHOWN ON
PAGES G-1
THROUGH G-19

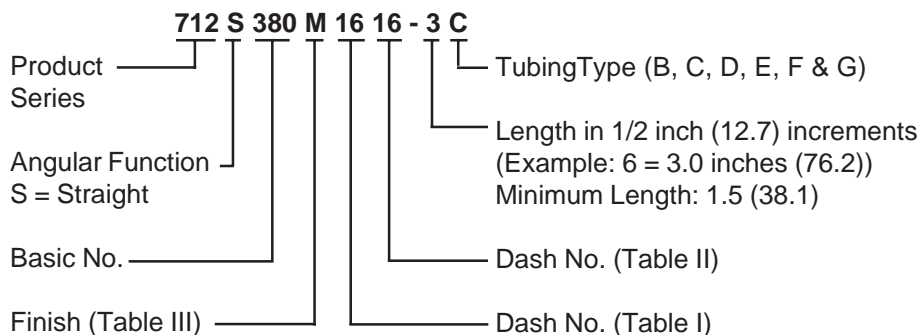

**TYPES C & F
ENVIRONMENTAL**

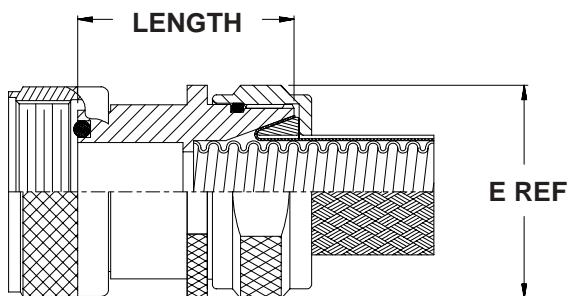

**TYPES B, D, & E
NON-ENVIRONMENTAL**

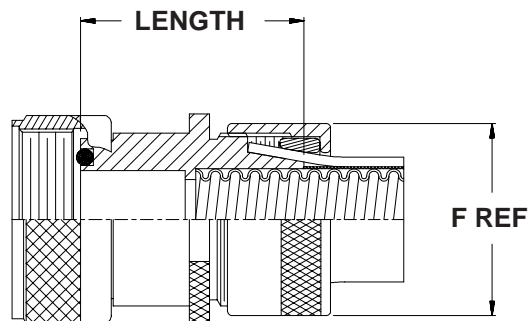

**TYPE G
ENVIRONMENTAL**

712-380 - Types B, C, D, E, F & G User-Installable Bulkhead Fitting for Series 74 Helical Convolute Tubing



DASH NO.	A THREAD CLASS 2B	B MAX	C DIA	MAX DASH NO. TABLE II
06	7/16 - 28 UNEF	.640 (16.3)	.188 (4.8)	06
09	9/16 - 24 UNEF	.690 (17.5)	.281 (7.1)	09
10	9/16 - 24 UNEF	.690 (17.5)	.312 (7.9)	10
12	5/8 - 24 UNEF	.760 (19.3)	.375 (9.5)	12
14	11/16 - 24 UNEF	.890 (22.6)	.438 (11.1)	14
16	3/4 - 20 UNEF	.890 (22.6)	.500 (12.7)	16
20	7/8 - 20 UNEF	1.024 (26.0)	.625 (15.9)	20
24	1 - 20 UNEF	1.152 (29.3)	.750 (19.1)	24
28	1 3/16 - 18 UNEF	1.363 (34.6)	.875 (22.2)	28
32	1 5/16 - 18 UNEF	1.488 (37.8)	1.000 (25.4)	32
40	1 1/2 - 18 UNEF	1.676 (42.6)	1.250 (31.8)	40
48	1 3/4 - 18 UNS	1.960 (49.8)	1.500 (38.1)	48
56	2 - 18 UNS	2.210 (56.1)	1.750 (44.5)	56
64	2 1/4 - 16 UN	2.460 (62.5)	2.000 (50.8)	64

DASH NO.	TUBING I.D.		D MAX	E MAX
	MIN	MAX		
06	.181 (4.6)	.188 (4.8)	1.09 (27.7)	.78 (19.8)
09	.273 (6.9)	.281 (7.1)	1.16 (29.5)	1.03 (26.2)
10	.306 (7.8)	.312 (7.9)	1.22 (31.0)	1.03 (26.2)
12	.359 (9.1)	.375 (9.5)	1.28 (32.5)	1.03 (26.2)
14	.427 (10.8)	.437 (11.1)	1.34 (34.0)	1.22 (31.0)
16	.480 (12.2)	.500 (12.7)	1.41 (35.8)	1.28 (32.5)
20	.603 (15.3)	.625 (15.9)	1.53 (38.9)	1.41 (35.8)
24	.725 (18.4)	.750 (19.1)	1.66 (42.2)	1.53 (38.9)
28	.860 (21.8)	.875 (22.2)	1.78 (45.2)	1.71 (43.4)
32	.970 (24.6)	1.000 (25.4)	1.91 (48.5)	1.84 (46.7)
40	1.205 (30.6)	1.250 (31.8)	2.28 (57.9)	2.16 (54.9)
48	1.437 (36.5)	1.500 (38.1)	2.59 (65.8)	2.46 (62.5)
56	1.688 (42.9)	1.750 (44.5)	2.91 (73.9)	2.78 (70.6)
64	1.937 (49.2)	2.000 (50.8)	3.03 (77.0)	3.03 (77.0)

SYMBOL	FINISH
B	Olive Drab over Cadmium Plate
J	Gold Iridite over Cadmium Plate over Nickel
M	Electroless Nickel
N	Olive Drab over Cadmium Plate over Nickel
NC	Zinc-Cobalt, Olive Drab
NF	Olive Drab over Cadmium Plate over Electroless Nickel (500 Hour Salt Spray)
T	Bright Dip Cadmium Plate over Nickel

NOTES:

1. Metric dimensions (mm) are in parentheses.
2. Tubing shown for reference only.