

Features

- Low Voltage Operation: 2.5V
- Low Harmonics: -70 dBc at +34 dBm & 1 GHz
- Low Insertion Loss: 0.5 dB at 1 GHz
- High Isolation: 20 dB at 2 GHz
- 0.5 micron GaAs PHEMT Process
- Supplied as Known Good Die

Description

M/A-COM's MASWSS0100 is a GaAs PHEMT MMIC single pole three throw (SP3T) high power switch die. The MASWSS0100 is ideally suited for applications where high power, low control voltage, low insertion loss, high isolation, small size and low cost are required.

Typical applications are for GSM, DCS and PCS handset systems that connect separate transmit and receive functions to a common antenna, as well as other handset and related applications. This part can be used in all systems operating up to 2.5 GHz requiring high power at low control voltage.

The MASWSS0100 is fabricated using a 0.5 micron gate length GaAs PHEMT process. The process features full passivation for performance and reliability.

Ordering Information¹

Part Number	Product Description
MASWSS0100-DIE	Separated Die on Grip Ring ¹

1. Die quantity varies.

Absolute Maximum Ratings^{2,3}

Parameter	Absolute Maximum
Input Power	+38 dBm
Voltage	± 8.5 volts
Operating Temperature	-40°C to +85°C
Storage Temperature	-65°C to +150°C

2. Exceeding any one or combination of these limits may cause permanent damage to this device.
3. M/A-COM does not recommend sustained operation near these survivability limits.

Die Bond Pad Layout

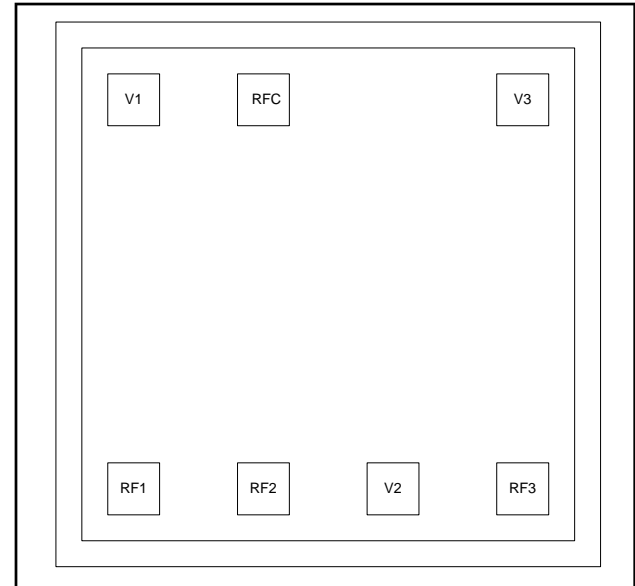

Pad Configuration

Pad Name	Description
V1	Control 1
RF1	RF Port 1
RF2	RF Port 2
V2	Control 2
RF3	RF Port 3
V3	Control 3
RFC	Antenna/Common Port

GaAs SP3T 2.5 V High Power Switch 0.1 - 3.0 GHz

Rev. V2

Electrical Specifications: $T_A = 25^\circ\text{C}$, $V_C = 0\text{ V} / 2.5\text{ V}$, $Z_0 = 50\ \Omega$ ⁴

Parameter	Test Conditions	Units	Min.	Typ.	Max.
Insertion Loss ⁵	0.5 - 1.0 GHz	dB	—	0.5	0.65
	1.0 - 2.0 GHz	dB	—	0.6	—
Isolation	0.5 - 1.0 GHz	dB	23	25	—
	1.0 - 2.0 GHz	dB	—	20	—
Return Loss	0.5 - 2.5 GHz	dB	—	20	—
P.1dB	—	dBm	—	38	—
2 nd Harmonic	1.0 GHz, $P_{IN} = +34\text{ dBm}$	dBc	—	-80	—
3 rd Harmonic	1.0 GHz, $P_{IN} = +34\text{ dBm}$	dBc	—	-70	-65
Trise, Tfall	10% to 90% RF, 90% to 10% RF	nS	—	83	—
Ton, Toff	50% control to 90% RF 50% control to 10% RF	nS	—	94	—
Transients	In Band	mV	—	58	—
Control Current	2.5 V	μA	—	50	80

4. External DC blocking capacitors are required on all RF ports.

5. Insertion loss can be optimized by varying the DC blocking capacitor value, e.g. 1000 pF for 100 MHz - 1 GHz, 39 pF for 0.5 - 3 GHz.

Functional Diagram

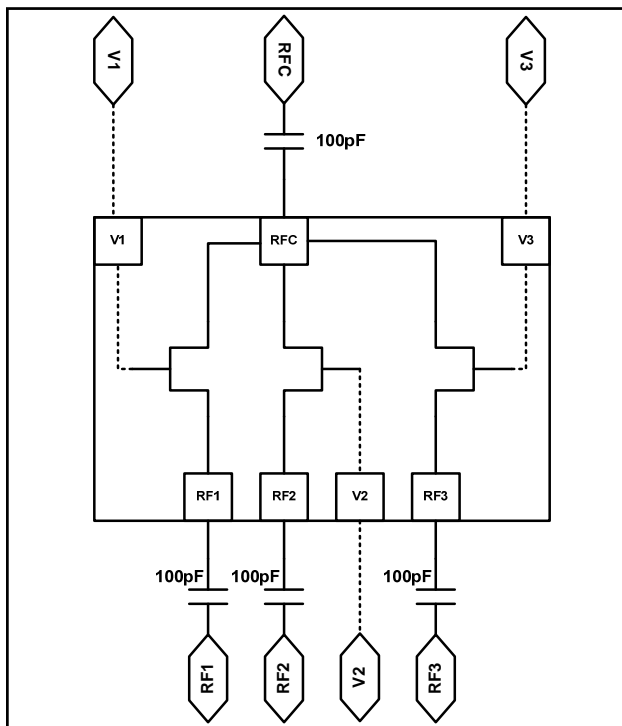

Truth Table^{6,7}

V1	V2	V3	RFC- RF1	RFC- RF2	RFC - RF3
1	0	0	On	Off	Off
0	1	0	Off	On	Off
0	0	1	Off	Off	On

6. State 0 = -5 V to +2.5 V, State 1 = -2.5 V to +5 V.

7. Differential voltage, V (state 1) - V (state 0), must be 2.5 V minimum.

Qualification

Qualified to M/A-COM specification REL-201, Process Flow -2.

Handling Procedures

Please observe the following precautions to avoid damage:

Static Sensitivity

Gallium Arsenide Integrated Circuits are sensitive to electrostatic discharge (ESD) and can be damaged by static electricity. Proper ESD control techniques should be used when handling these devices.

Typical Performance Curves

Insertion Loss vs. Frequency

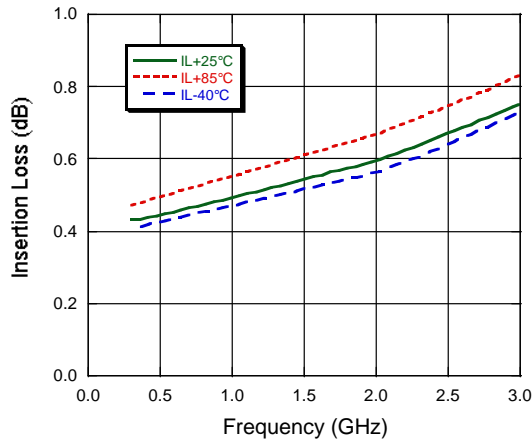

Isolation vs. Frequency

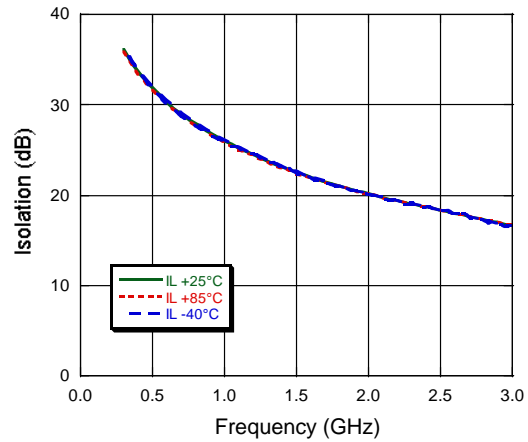

2nd Harmonic vs. V_C

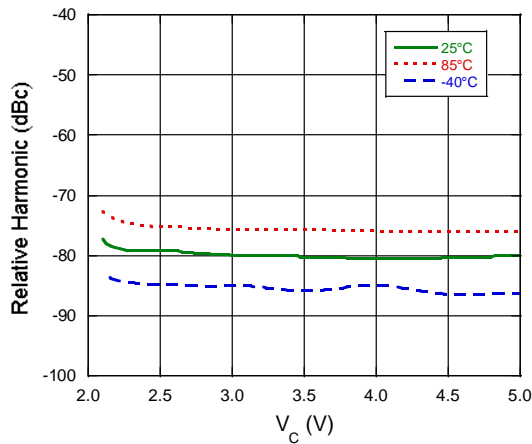

3rd Harmonic vs. V_C

