

---

## Features

---

- Power-on reset generator with fixed delay time of 200ms Typ
- Manual reset input (APX823/APX825A)
- Reset output available in active-Low (APX823/APX824/APX825A), active-high (APX824/APX825A)
- Supply voltage supervision range 2.5V, 3V, 3.3V, 5V
- Watchdog timer
- Supply current of 30 $\mu$ A (Typ.)
- Temperature range: -40°C to 85°C
- SOT25 and SOT26: Available in "Green" Molding Compound (No Br, Sb)
- Lead Free Finish/RoHS Compliant (Note 1)

---

## General Description

---

The APX823/APX824/APX825A family of supervisors provides circuit initialization and timing supervision, primarily for DSP and processor-based systems.

During power-on, **RESET** is asserted when supply voltage  $V_{CC}$  becomes higher than 1.1V. Thereafter, the supply voltage supervisor monitors  $V_{CC}$  and keeps **RESET** active as long as  $V_{CC}$  remains below the threshold voltage  $V_{TH}$ . An internal timer delays the return of the output to the inactive state (high) to ensure proper system reset. The delay time  $t_d$ , starts after  $V_{CC}$  has risen above the threshold voltage  $V_{TH}$ . When the supply voltage drops below the threshold voltage  $V_{TH}$ , the output becomes active (low) again. No external components are required. All the devices of this family have a fixed-sense threshold voltage  $V_{TH}$  set by an internal voltage divider.

The APX823/APX825A devices incorporate a manual reset input, **MR**. A low level at **MR** causes **RESET** to become active. The APX824/APX825A devices include a high-level output **RESET**. APX823/APX824/APX825A have a watchdog timer that is periodically triggered by a positive or negative transition at **WDI**. When the supervising system fails to retrigger the watchdog circuit within the time-out interval,  $t_{out}$ , **RESET** becomes active for the time period  $t_d$ . This event also reinitializes the watchdog timer. Leaving **WDI** unconnected disables the watchdog.

In applications where the input to the **WDI** pin may be active (transitioning high and low) when the APX823/APX824/APX825A asserting **RESET**, the APX823/APX824/APX825A does not return to a non-reset state when the input voltage is above  $V_t$ .

The product spectrum is designed for supply voltage of 2.5V, 3V, 3.3V and 5V. The circuits are available in a SOT25 and SOT26 packages. The APX823/APX824/APX825A devices are characterized for operation over a temperature range of -40°C to 105°C.

---

## Applications

---

- Applications Using DSPs, Microcontrollers, or Microprocessors
- Industrial Equipment
- Programmable Controls
- Automotive Systems
- Portable/Battery-Powered Equipment
- Intelligent Instruments
- Wireless Communications Systems
- Notebook/Desktop Computers

### Ordering Information

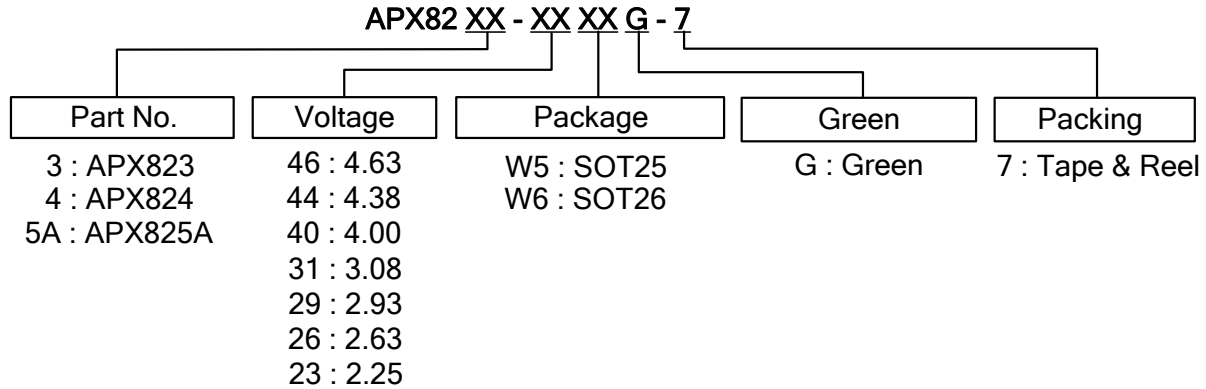

Device	Package Code	Packaging (Note 2)	7" Tape and Reel	
			Quantity	Part Number Suffix
APX823-XXW5G-7	W5	SOT25	3000/Tape & Reel	-7
APX824-XXW5G-7	W5	SOT25	3000/Tape & Reel	-7
APX825A-XXW6G-7	W6	SOT26	3000/Tape & Reel	-7

Notes: 1. EU Directive 2002/95/EC (RoHS). All applicable RoHS exemptions applied. Please visit our website at [http://www.diodes.com/products/lead\\_free.html](http://www.diodes.com/products/lead_free.html).  
 2. Pad layout as shown on Diodes Inc. suggested pad layout document AP02001, which can be found on our website at <http://www.diodes.com/datasheets/ap02001.pdf>.

### Pin Assignments

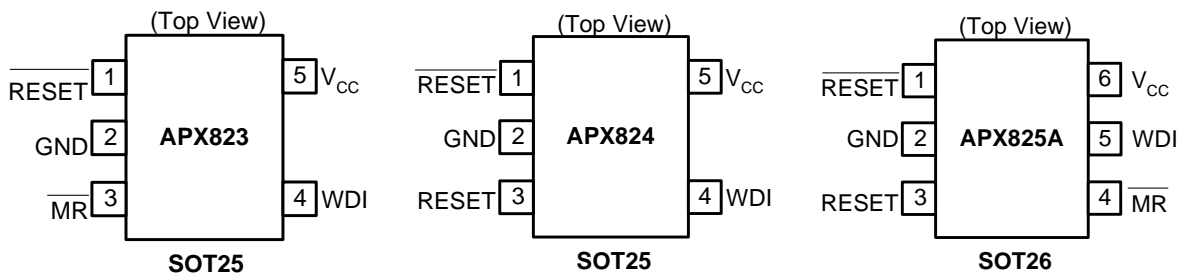

### Pin Descriptions

Pin Name	Description
GND	Ground
RESET (RESET)	Reset output pin
V <sub>CC</sub>	Operating voltage input
WDI	Watchdog input
MR	Manual reset

### Absolute Maximum Ratings

(Over operating ambient temperature range, unless otherwise noted)\*

Symbol	Parameter	Rating	Unit		
ESD HBM	Human Body Model ESD Protection	5	KV		
ESD MM	Machine Model ESD Protection	200	V		
V <sub>CC</sub>	Supply Voltage	6.0	V		
V <sub>RESET</sub>	RESET, RESET, MR, WDI	-0.3 to (V <sub>CC</sub> +0.3)	V		
I <sub>CC</sub>	Input Current V <sub>CC</sub>	20	mA		
I <sub>O</sub>	Maximum High Output Current	20	mA		
P <sub>D</sub>	Continuous Total Power Dissipation	Derating Factor Above T <sub>A</sub> = 25°C	SOT25	6.2	mW/°C
			SOT26	5.8	
		T <sub>A</sub> = 25°C Power Rating	SOT25	500	mW
			SOT26	470	
		T <sub>A</sub> = 70°C Power Rating	SOT25	220	mW
			SOT26	210	
T <sub>A</sub> = 85°C Power Rating	SOT25	125	mW		
	SOT26	120			
T <sub>OP</sub>	Operating Junction Temperature Range	-40 to 105	°C		
T <sub>ST</sub>	Storage Temperature Range	-65 to 150	°C		

\* Stresses beyond those listed under "absolute maximum ratings" may cause permanent damage to the device. These are stress ratings only, and functional operation of the device at these or any other conditions beyond those indicated under "recommended operating conditions" is not implied. Exposure to absolute-maximum-rated conditions for extended periods may affect device reliability.

### Recommended Operating Conditions

Symbol	Parameter	Min	Max	Unit
$V_{CC}$	Supply Voltage	1.1	5.5	V
$V_{IN}$	Input Voltage	0	$(V_{CC}+0.3)$	V
$V_{IH}$	High-level Input Voltage at $\overline{MR}$ and WDI	$0.7 \times V_{CC}$	-	V
$V_{IL}$	Low-level Input Voltage	-	$0.3 \times V_{CC}$	V
$\Delta t/\Delta V$	Input Transition Rise and Fall Rate at $\overline{MR}$ or WDI	-	100	ns/V
$T_A$	Operating Ambient Temperature Range	-40	85	°C
$T_R$	$V_{CC}$ Rising Time ( $V_{CC} = 0 \sim V_T$ )	-	100	V/ $\mu$ S

### Electrical Characteristics

(Over recommended operating ambient temperature range, unless otherwise noted)

Symbol	Parameter		Test Conditions	Min	Typ.	Max	Unit	
$V_{OH}$	High-level Output Voltage	$\overline{RESET}$	APX823/APX824/APX825A -29/26/23	$V_{CC} = \underline{V_{TH}} + 0.2V$ $I_{OH} = -20\mu A$	$0.8 \times V_{CC}$	-	-	V
			APX823/APX824/APX825A -40/31	$V_{CC} = \underline{V_{TH}} + 0.2V$ $I_{OH} = -30\mu A$				
			APX823/APX824/APX825A -46/44	$V_{CC} = \underline{V_{TH}} + 0.2V$ $I_{OH} = -120\mu A$				
		$\overline{RESET}$	APX824/APX825A -29/26/23	$V_{CC} \geq 1.8V$ , $I_{OH} = -100\mu A$	$0.8 \times V_{CC}$	-	-	V
			APX824/APX825A -46/44/40/31	$V_{CC} \geq 1.8V$ , $I_{OH} = -150\mu A$				
$V_{OL}$	Low-level Output Voltage	$\overline{RESET}$	APX824/APX825A -29/26/23	$V_{CC} = \underline{V_{TH}} + 0.2V$ $I_{OL} = 1mA$	-	-	0.4	V
			APX824/APX825A -40/31	$V_{CC} = \underline{V_{TH}} + 0.2V$ $I_{OL} = 1.2mA$				
			APX824/APX825A -46/44	$V_{CC} = \underline{V_{TH}} + 0.2V$ $I_{OL} = 3mA$				
		$\overline{RESET}$	APX823/APX824/APX825A -29/26/23	$V_{CC} = \underline{V_{TH}} - 0.2V$ $I_{OL} = 1mA$	-	-	0.4	V
			APX823/APX824/APX825A -40/31	$V_{CC} = \underline{V_{TH}} - 0.2V$ $I_{OL} = 1.2mA$				
			APX823/APX824/APX825A -46/44	$V_{CC} = \underline{V_{TH}} - 0.2V$ $I_{OL} = 3mA$				
$V_{RESET}$	Power-up Reset Voltage (see Note 3)		$V_{CC} \geq 1.1V$ , $I_{OL} = 20\mu A$	-	-	0.4	V	

Notes: 3. The lowest supply voltage at which  $\overline{RESET}$  becomes active.  $T_R$ ,  $V_{CC} \geq 15\mu s/V$ .

### Electrical Characteristics (Continued)

(Over recommended operating ambient temperature range, unless otherwise noted)

Symbol	Parameter		Test Conditions	Min	Typ.	Max	Unit
$V_{TH}$	Negative-going Input Threshold Voltage (see Note 4)	APX823/APX824/APX825A -23	$T_A = 0^\circ\text{C} - 85^\circ\text{C}$	2.21	2.25	2.30	V
		APX823/APX824/APX825A -26		2.59	2.63	2.69	
		APX823/APX824/APX825A -29		2.88	2.93	3.00	
		APX823/APX824/APX825A -31		3.02	3.08	3.15	
		APX823/APX824/APX825A -40		3.93	4.00	4.08	
		APX823/APX824/APX825A -44		4.31	4.38	4.47	
		APX823/APX824/APX825A -46		4.56	4.63	4.72	
		APX823/APX824/APX825A -23		$T_A = -40^\circ\text{C} - 85^\circ\text{C}$	2.20	2.25	
		APX823/APX824/APX825A -26	2.57		2.63	2.69	
		APX823/APX824/APX825A -29	2.86		2.93	3.00	
		APX823/APX824/APX825A -31	3.00		3.08	3.15	
		APX823/APX824/APX825A -40	3.92		4.00	4.08	
		APX823/APX824/APX825A -44	4.29		4.38	4.47	
		$V_{hys}$	Hysteresis at $V_{CC}$ Input	APX823/APX824/APX825A -23		-	50
APX823/APX824/APX825A -26	-			50		-	
APX823/APX824/APX825A -29	-			50		-	
APX823/APX824/APX825A -31	-			50		-	
APX823/APX824/APX825A -40	-			50		-	
APX823/APX824/APX825A -44	-			50		-	
$T_S$	Set-up Time	$V_{CC} = V_{TH}$ to $(V_{TH} - 100\text{mV})$		20		$\mu\text{s}$	
$I_{IH(AV)}$	Average High-level Input Current		WDI= $V_{CC}$ , Time average (dc=88%)	-	120	-	$\mu\text{A}$
$I_{IL(AV)}$	Average Low-level Input Current	WDI	WDI=0.3V, $V_{CC}=5.5\text{V}$ time average (dc=12%)	-	-15	-	$\mu\text{A}$
$I_{IH}$	High-level Input Current	WDI	WDI= $V_{CC}$	-	120	160	$\mu\text{A}$
$I_{IL}$	Low-level Input Current	WDI	WDI=0.3V, $V_{CC}=5.5\text{V}$	-	120	160	$\mu\text{A}$
$I_{CC}$	Supply Current	WDI and MR Unconnected, Outputs unconnected	$V_{CC} = \underline{V_{TH}} + 0.2\text{V}$	-	30	40	$\mu\text{A}$
	Internal Pull-up Resistor at MR			-	60	-	k $\Omega$
TC	$V_{OUT}$ Temperature Coefficient				50	-	ppm/ $^\circ\text{C}$
$C_i$	Input Capacitance at MR, WDI		$V_I = 0\text{V}$ to 5.5V	-	5	-	pF
$\theta_{JA}$	Thermal Resistance Junction-to-Ambient	SOT25 (Note 6)			161		$^\circ\text{C/W}$
		SOT26 (Note 6)			169		
$\theta_{JC}$	Thermal Resistance Junction-to-Case	SOT25 (Note 6)			27		$^\circ\text{C/W}$
		SOT26 (Note 6)			28		

Notes: 4. To ensure best stability of the threshold voltage, a bypass capacitor (ceramic, 0.1 $\mu\text{F}$ ) should be placed near the supply terminals.

5. The RESET short-circuit current is the maximum pull-up current when RESET is driven low by a P bidirectional reset pin.

6. Test condition for SOT25 and SOT26: Devices mounted on FR-4 substrate PC board, 2oz copper, with minimum recommended pad layout.

### Timing requirements (at $R_L=1m\Omega$ , $C_L=50pF$ , $T_A=25^\circ C$ )

Symbol	Parameter	Test Conditions	Min	Typ.	Max	Unit	
$t_w$	Pulse Width	at $\overline{MR}$	$V_{CC} \geq \underline{V_{TH}} + 0.2V$ , $V_{IL} = 0.3 \times V_{CC}$ , $V_{IH} = 0.7 \times V_{CC}$	<u>100</u>	-	-	ns
		at $\overline{WDI}$	$V_{CC} \geq \underline{V_{TH}} + 0.2V$ , $V_{IL} = 0.3 \times V_{CC}$ , $V_{IH} = 0.7 \times V_{CC}$	<u>50</u>	-	-	ns

### Switching Characteristics (at $R_L=1m\Omega$ , $C_L=50pF$ , $T_A=25^\circ C$ )

Symbol	Parameter	Test Conditions	Min	Typ.	Max	Unit	
$t_{tout}$	Watchdog Time Out	APX823/APX824/APX825A $V_{CC} \geq \underline{V_{TH}} + 0.2V$ , See timing diagram	<u>1.12</u>	1.6	<u>2.4</u>	s	
$t_d$	Delay Time	APX823/APX824/APX825A $V_{CC} \geq \underline{V_{TH}} + 0.2V$ , See timing diagram	140	200	280	ms	
$t_{PHL}$	Propagation (Delay) Time, High-to-low-level Output	$\overline{MR}$ to $\overline{RESET}$ delay (APX823/APX825A)	$V_{CC} > \underline{V_{TH}} + 0.2V$ , $V_{IL} = 0.3 \times V_{CC}$ , $V_{IH} = 0.7 \times V_{CC}$	-	-	0.1	$\mu s$
		$V_{CC}$ to $\overline{RESET}$ delay	$V_{IL} = \underline{V_{TH}} - 0.2V$ , $V_{IH} = \underline{V_{TH}} + 0.2V$	-	-	25	$\mu s$
$t_{PLH}$	Propagation (Delay) Time, Low-to-high-level Output	$\overline{MR}$ to $\overline{RESET}$ delay (APX824/APX825A)	$V_{CC} > \underline{V_{TH}} + 0.2V$ , $V_{IL} = 0.3 \times V_{CC}$ , $V_{IH} = 0.7 \times V_{CC}$	-	-	0.1	$\mu s$
		$V_{CC}$ to $\overline{RESET}$ delay (APX824/APX825A)	$V_{IL} = \underline{V_{TH}} - 0.2V$ , $V_{IH} = \underline{V_{TH}} + 0.2V$	-	-	25	$\mu s$

**Application Circuit**

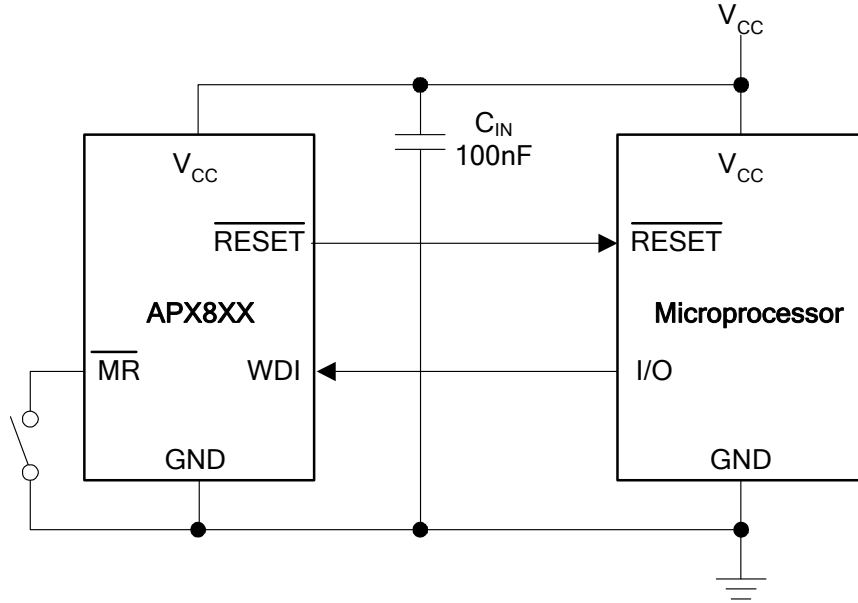

**Functional Block Diagram**

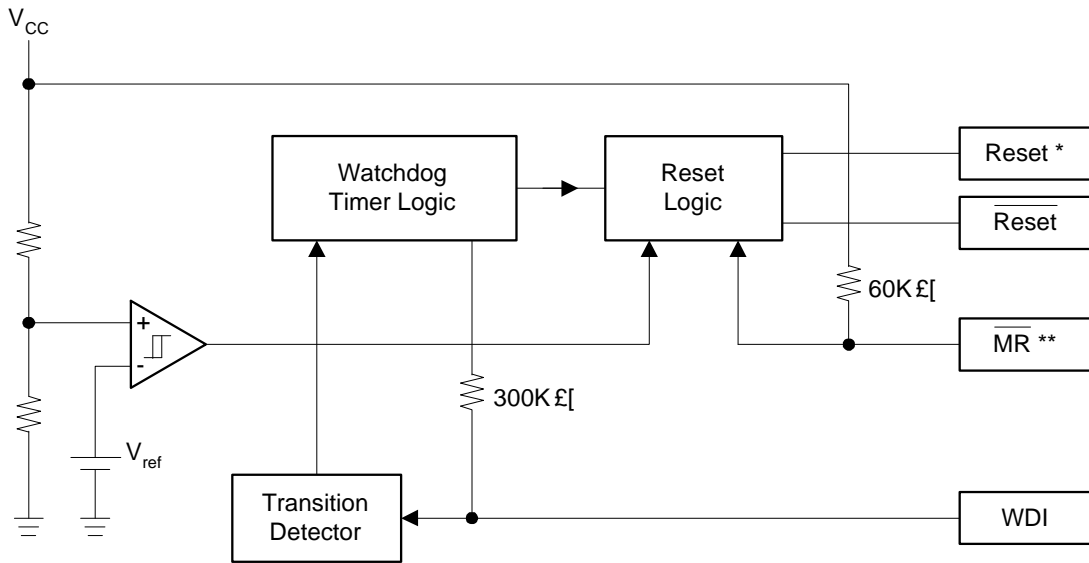

\* APX824/APX825A  
\*\* APX823/APX825A

**Timing Diagram**

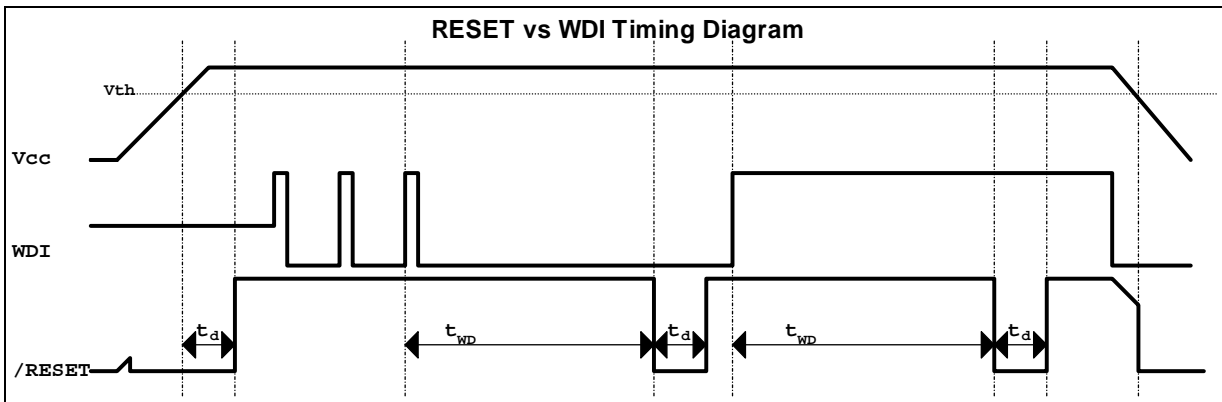
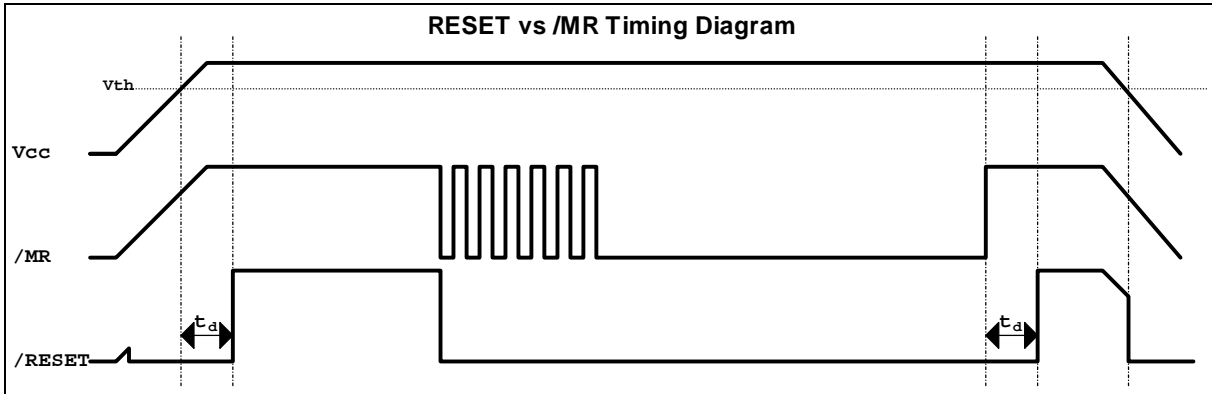
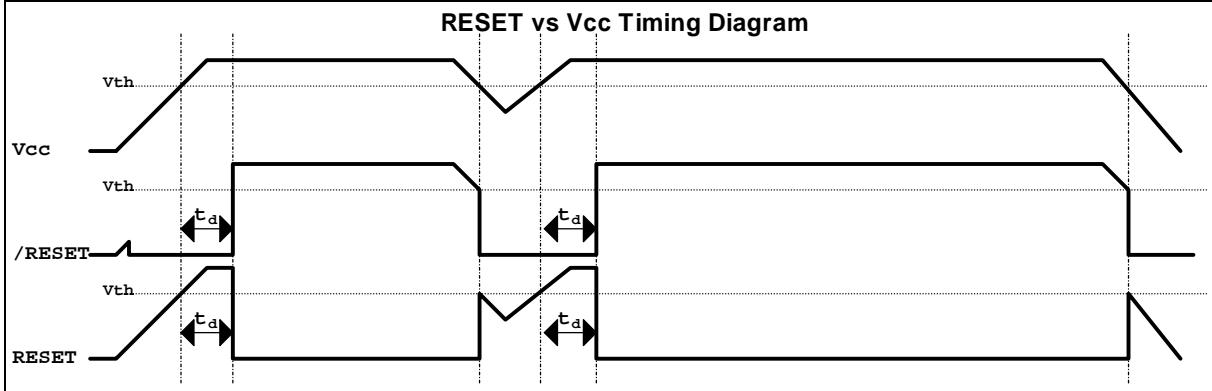



**Typical Characteristics**

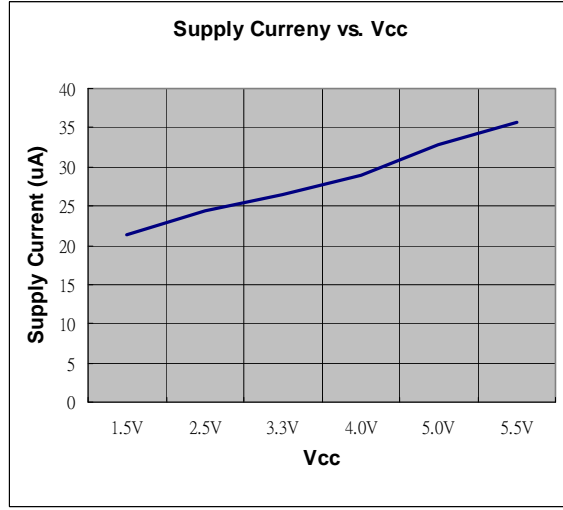
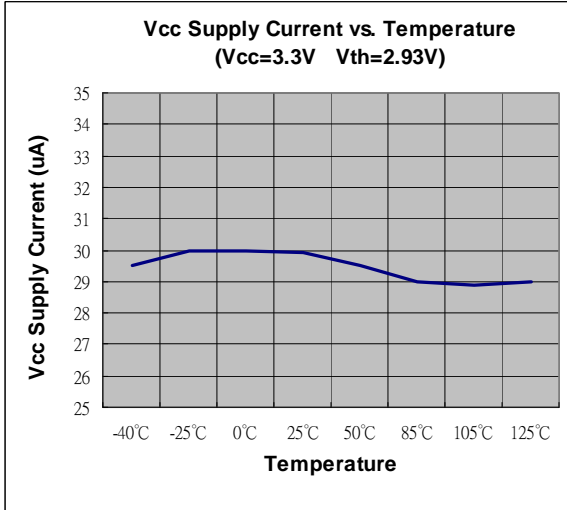
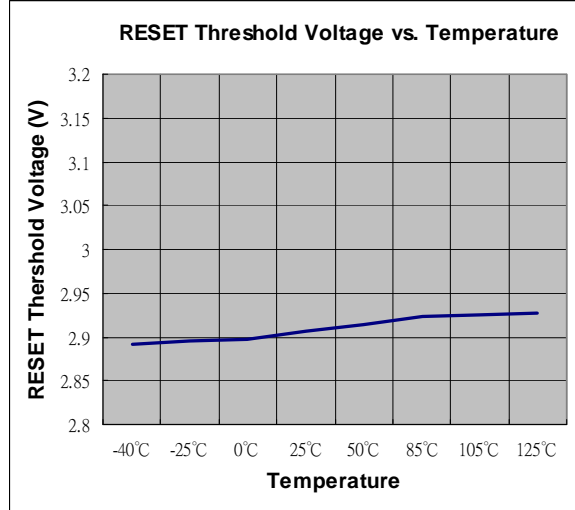
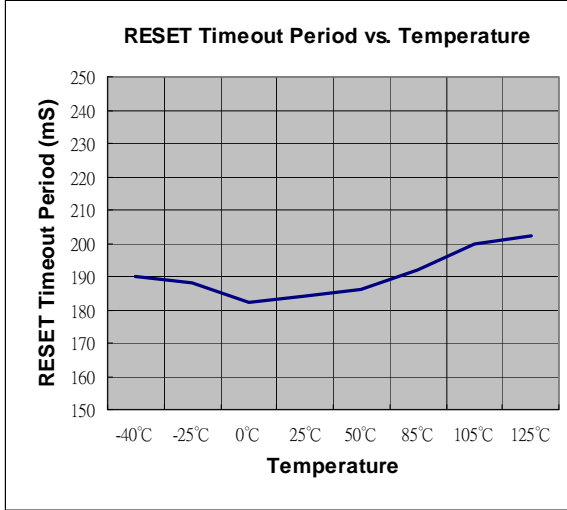

### Marking Information

(1) SOT25

( Top View )

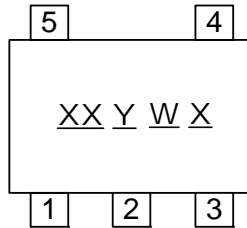

XX : Identification code  
Y : Year 0~9  
W : Week : A~Z : 1~26 week;  
a~z : 27~52 week; z represents  
52 and 53 week  
X : A~Z : Green

(2) SOT26

( Top View )

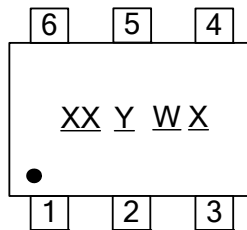

XX : Identification code  
Y : Year 0~9  
W : Week : A~Z : 1~26 week;  
a~z : 27~52 week; z represents  
52 and 53 week  
X : A~Z : Green

Marking Table

Device	Package Type	Identification Code
APX823-46W5	SOT25	W1
APX823-44W5	SOT25	W2
APX823-40W5	SOT25	W3
APX823-31W5	SOT25	W4
APX823-29W5	SOT25	W5
APX823-26W5	SOT25	W6
APX823-23W5	SOT25	W7
APX824-46W5	SOT25	T2
APX824-44W5	SOT25	T3
APX824-40W5	SOT25	T4
APX824-31W5	SOT25	T5
APX824-29W5	SOT25	T6
APX824-26W5	SOT25	T7
APX824-23W5	SOT25	T8
APX825A-46W6	SOT26	T9
APX825A-44W6	SOT26	TA
APX825A-40W6	SOT26	TB
APX825A-31W6	SOT26	TC
APX825A-29W6	SOT26	TD
APX825A-26W6	SOT26	TE
APX825A-23W6	SOT26	TF

**Package Information (All Dimensions in mm)**

**(1) Package Type: SOT25**

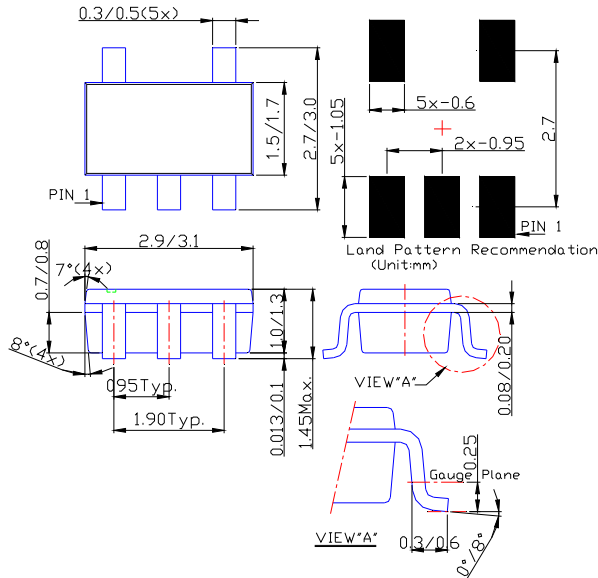

**(2) Package Type: SOT26**

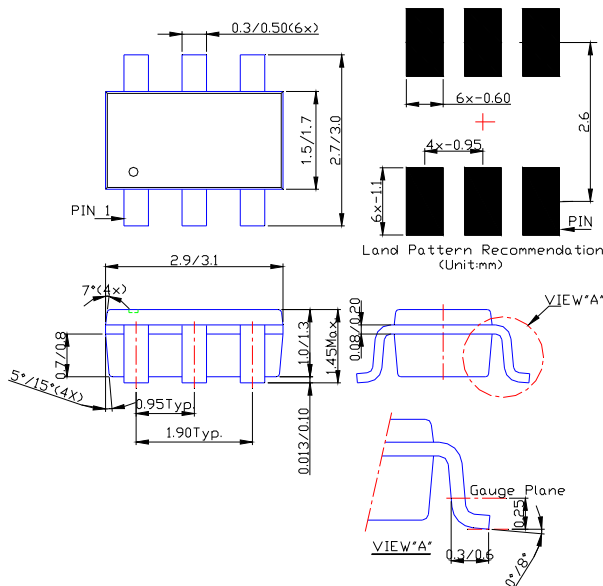

Notes: 7. Package outline dimensions as shown on Diodes Inc. package outline dimensions document AP02002, which can be found on our website at <http://www.diodes.com/datasheets/ap02002.pdf>

### IMPORTANT NOTICE

Diodes Incorporated and its subsidiaries reserve the right to make modifications, enhancements, improvements, corrections or other changes without further notice to any product herein. Diodes Incorporated does not assume any liability arising out of the application or use of any product described herein; neither does it convey any license under its patent rights, nor the rights of others. The user of products in such applications shall assume all risks of such use and will agree to hold Diodes Incorporated and all the companies whose products are represented on our website, harmless against all damages.

### LIFE SUPPORT

Diodes Incorporated products are not authorized for use as critical components in life support devices or systems without the expressed written approval of the President of Diodes Incorporated.