

10Base-T Interface Module with Enhanced Common Mode Attenuation

EPA1829BG-RC

- General Purpose 10Base-T Filter Module
- Complies with or exceeds IEEE 802.3, 10Base-T Standards
- Add “-RC” after part number for RoHS Compliant
- Available in SMD, DIP and DIL Packages

Electrical Parameters @ 25° C

Cut-Off Frequency (MHz)	Insertion * Loss (dB Max.)	Return Loss (dB Min.)	Attenuation (dB Min.)				Common Mode Rejection (dB Min.)		Crosstalk (dB Min.)
			@ 20 MHz	@ 25 MHz	@ 30 MHz	@ 40 MHz	@ 50 MHz	@ 100 MHz	
± 1.0 MHz	1-10 MHz	5-10 MHz	@ 20 MHz	@ 25 MHz	@ 30 MHz	@ 40 MHz	@ 50 MHz	@ 100 MHz	1-10 MHz
Xmit/Rcv	Xmit/Rcv	Xmit/Rcv	Xmit/Rcv	Xmit/Rcv	Xmit/Rcv	Xmit/Rcv	Xmit/Rcv	Xmit/Rcv	Xmit/Rcv
17/17	-1/-1	-15/-15	-7/-6	-19/-14	-30/-20	-35/-31	-40/-40	-30/-30	-30/-30

- **Isolation** : meets or exceeds 802.3 IEEE Requirements
- **Characteristic Filter Impedance** : 100
- *Referenced to the Output Level Fundamental Frequency @ 5 MHz
- CMC is common to both channels

Package

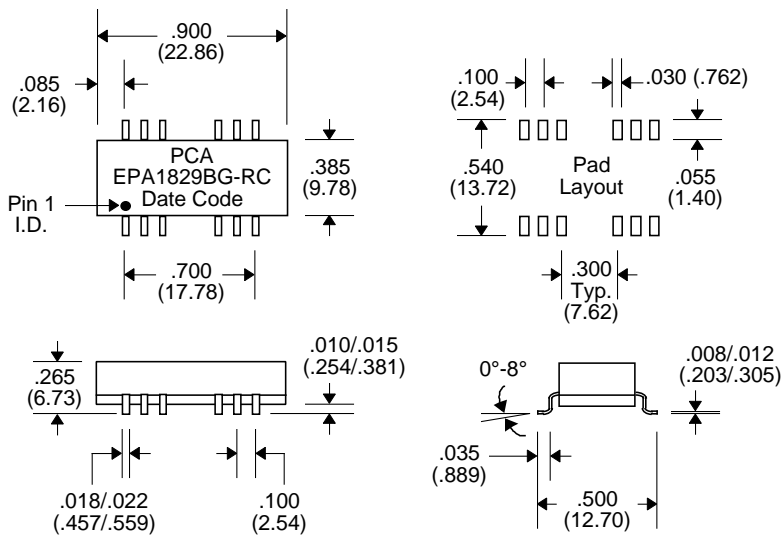

Schematic

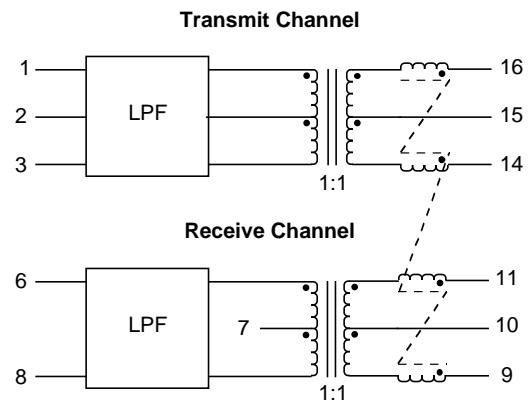

Notes :	EPA1829BG-RC
1. Lead Finish	Hot Tin Dip (Sn) †
2. Peak Temperature Rating	245°C
3. Moisture Sensitive Levels	MSL = 4 (72 Hours, 30°C/60%RH)
4. Weight	1.85 grams
5. Packaging Information	(Tube) 19 pieces/tube (Tape & Reel) 550 pieces/13" reel

† Lead Material : Ni Barrier over Cu

Unless Otherwise Specified Dimensions are in Inches /mm ± .010 / .25