

100 Ω To 150 Ω Adapter With Common Mode Choke For Token Ring

PCA Part Number(s)		EPA2211D			
Electrical Specifications @ 25°C					
Parameter	Frequency	Specification	XMIT	RCV	Unit
Insertion Loss	1-16 MHz	0.5			dB Max.
Return Loss	1 MHz	25.0			dB Min.
	5 MHz	20.0			dB Min.
	10 MHz	20.0			dB Min.
	16 MHz	20.0			dB Min.
	24 MHz	15.0			dB Min.
Common Mode Attenu.	10-40 MHz	25.0			dB Min.
Impedance Ratio	N/A	100 : 150			Ω
Notes :					

Schematic

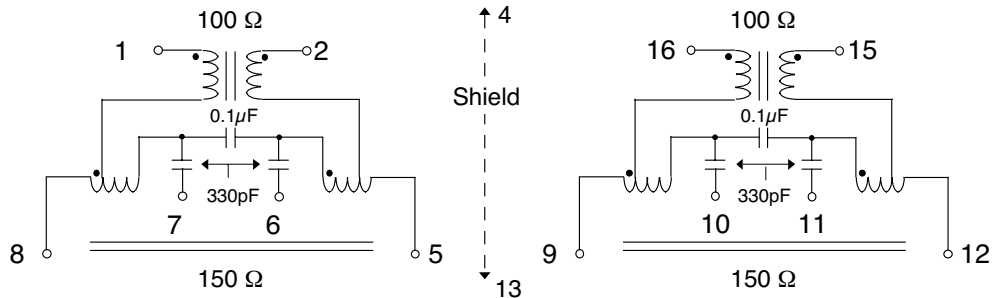

Package

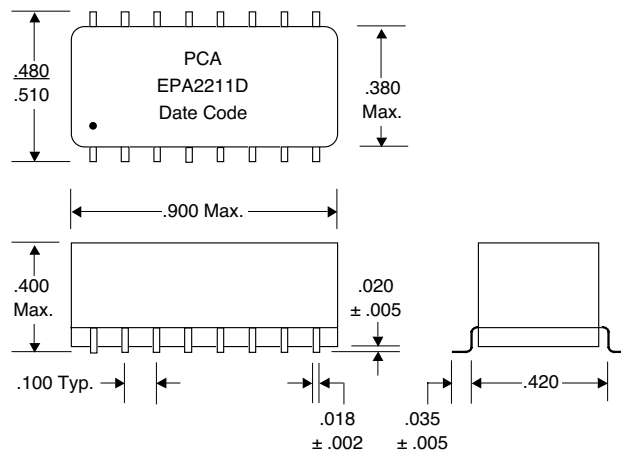

Pad Layout

