

B2000RUI Series



Compact, High Isolation 4:1 Input Range, 20W DC/DC Converters

Key Features:

- 20W Output Power
- 4:1 Input Voltage Range
- Compact 1 x 2 Inch Case
- 2,500 VDC Isolation
- High Efficiency
- Single & Dual Outputs
- Remote ON/OFF
- Industry Standard Pin-Out



Electrical Specifications

Specifications typical @ +25°C, nominal input voltage & rated output current, unless otherwise noted. Specifications subject to change without notice.

Input

Parameter	Conditions	Min.	Typ.	Max.	Units
Input Voltage Range	24 VDC Input	9.0	24.0	36.0	VDC
	48 VDC Input	18.0	48.0	72.0	
Input Filter	π (Pi) Filter				
Reverse Polarity Input Current				2.0	A
Short Circuit Input Power				3,500	mW

Output

Parameter	Conditions	Min.	Typ.	Max.	Units
Output Voltage Accuracy			±1.0		%
Output Voltage Balance	Dual Output , Balanced Loads		±0.5		%
Line Regulation	Vin = Min to Max			±0.5	%
Load Regulation, Single Output	Iout = 0% to 100%			±0.5	%
Load Regulation, Dual Output	Iout = 0% to 100%			±1.0	%
Ripple & Noise (20 MHz) (Note 1)				75	mV P - P
Output Power Protection			120		%
Transient Recovery Time (Note 2)	25% Load Step Change		250		μSec
Transient Response Deviation				±3.0	%
Temperature Coefficient			±0.02		%/°C
Output Short Circuit	Continuous (Autorecovery)				

General

Parameter	Conditions	Min.	Typ.	Max.	Units
Isolation Voltage (Input/Output)	60 Seconds	2,500			VDC
Isolation Voltage (Case/Input/output)		1,600			VDC
Isolation Resistance	500 VDC	1,000			MΩ
Isolation Capacitance	100 kHz, 1V		1,200		pF
Switching Frequency			330		kHz

Environmental

Parameter	Conditions	Min.	Typ.	Max.	Units
Operating Temperature Range	Ambient	-40	+25	+50	°C
Operating Temperature Range	Case			+105	°C
Storage Temperature Range		-40		+125	°C
Cooling	Free Air Convection				
Humidity	RH, Non-condensing			95	%
RFI	Six-Side Shielded Metal Case				

Physical

Case Size	2.0 x 1.0 x 0.40 Inches (50.8 x 25.4 x 10.2 mm)				
Case Material	Metal with Non-Conductive Base (UL94-V0)				
Weight	1.06 Oz (30g)				

Reliability Specifications

Parameter	Conditions	Min.	Typ.	Max.	Units
MTBF	MIL HDBK 217F, 25°C, Gnd Benign	560			kHours

Absolute Maximum Ratings

Parameter	Conditions	Min.	Typ.	Max.	Units
Input Voltage Surge (1 Sec)	24 VDC Input	-0.7		50.0	VDC
	48 VDC Input	-0.7		100.0	
Lead Temperature	1.5 mm From Case For 10 Sec			260.0	°C
Internal Power Dissipation	All Models			4,500	mW

Caution: Exceeding Absolute Maximum Ratings may damage the module. These are not continuous operating ratings.

MicroPower Direct

292 Page Street
Suite D
Stoughton, MA 02072
USA

T: (781) 344-8226

F: (781) 344-8481

E: sales@micropowerdirect.com

W: www.micropowerdirect.com



www.micropowerdirect.com

Model Number	Input				Output			Over Voltage Protection (VDC)	Efficiency (% Typ)	Max Capacitive Load (µF Max)	Fuse Rating Slow-Blow (mA)
	Voltage (VDC)		Current (mA)		Voltage (VDC)	Current (mA, Max)	Current (mA, Min)				
	Nominal	Range	Full-Load	No-Load							
B2001RUI	24	9.0 - 36.0	879	50	3.3	5,500.0	0.0	3.9	89	10,000	2,000
B2002RUI	24	9.0 - 36.0	957	50	5.0	4,000.0	0.0	6.8	90	6,800	2,000
B2003RUI	24	9.0 - 36.0	980	22	12.0	1,670.0	0.0	15.0	88	1,000	2,000
B2004RUI	24	9.0 - 36.0	968	22	15.0	1,330.0	0.0	18.0	89	680	2,000
B2005RUI	24	9.0 - 36.0	968	65	±5.0	±2000.0	0.0	±6.2	89	±2,200	2,000
B2006RUI	24	9.0 - 36.0	980	25	±12.0	±835.0	0.0	±15.0	88	±470	2,000
B2007RUI	24	9.0 - 36.0	980	25	±15.0	±665.0	0.0	±18.0	88	±330	2,000
B2011RUI	48	18.0 - 75.0	440	30	3.3	5,500.0	0.0	3.9	89	10,000	1,500
B2012RUI	48	18.0 - 75.0	457	30	5.0	4,000.0	0.0	6.8	91	6,800	1,500
B2013RUI	48	18.0 - 75.0	484	15	12.0	1,670.0	0.0	15.0	89	1,000	1,500
B2014RUI	48	18.0 - 75.0	484	15	15.0	1,330.0	0.0	18.0	89	680	1,500
B2016RUI	48	18.0 - 75.0	484	45	±5.0	±2000.0	0.0	±6.2	89	±2,200	1,500
B2016RUI	48	18.0 - 75.0	490	15	±12.0	±835.0	0.0	±15.0	88	±470	1,500
B2017RUI	48	18.0 - 75.0	490	15	±15.0	±665.0	0.0	±18.0	88	±330	1,500

Notes:

- When measuring output ripple, it is recommended that an external 1.0 µF ceramic capacitor be placed from the +Vout pin to the -Vout pin for single output units and from each output to common for dual output units.
- Transient recovery is measured to within a 1% error band for a load step change of 75% to 100%.
- Operation at no-load will not damage these units. However, they may not meet all specifications.
- Dual output units may be connected to provide a 10 VDC, 24 VDC or 30 VDC output. To do this, connect the load across the positive (+Vout) and negative (-Vout) outputs and float the output common.
- With the addition of a simple input Pi filter, the unit should meet the conducted emissions requirements of EN55022 class A. Typical component values would be 2.2 µF/100V for the two capacitors and 12 µH for the inductor. The filter components should be mounted as close to the unit as possible.
- It is recommended that a fuse be used on the input of a power supply for protection. See the table above for the correct rating.

Remote ON/OFF (Optional, see below)

Parameter	Min	Max	Units
Supply On	3.0	12 or Open	VDC
Supply Off	0.0	1.2	VDC
Standby Input Current	5 mA Typical		
Control Common	Referenced to Neg. Input (pin 2)		

Output Trim (Single Output Models)

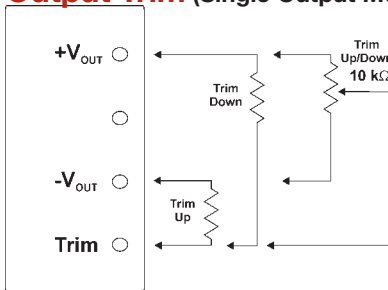

A simple external circuit may be used to adjust the converter output. To adjust the output DOWN, connect a 5%, 3W resistor between the plus output pin and the Vout trim pin. To adjust the output UP, connect a 5%, 3W resistor between the minus output pin and the Vout trim pin.

For UP/Down trimming capability, connect a 10 kW potentiometer between the plus and minus outputs with the wiper arm connected to the Vout trim pin.

Care should be taken that the maximum output power of the unit does not exceed the maximum rating.

Trim Down	-5%	-10%	Units
Vout =	11.400	10.800	VDC
Rtrim - Down =	38.591	5.264	kΩ
Trim Up	+5%	+10%	Units
Vout =	12.600	13.200	VDC
Rtrim - Up =	63.489	22.094	kΩ

Derating Curve

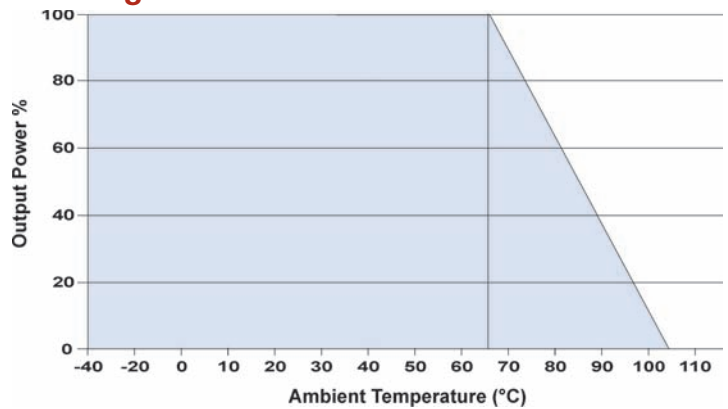

Mechanical Dimensions

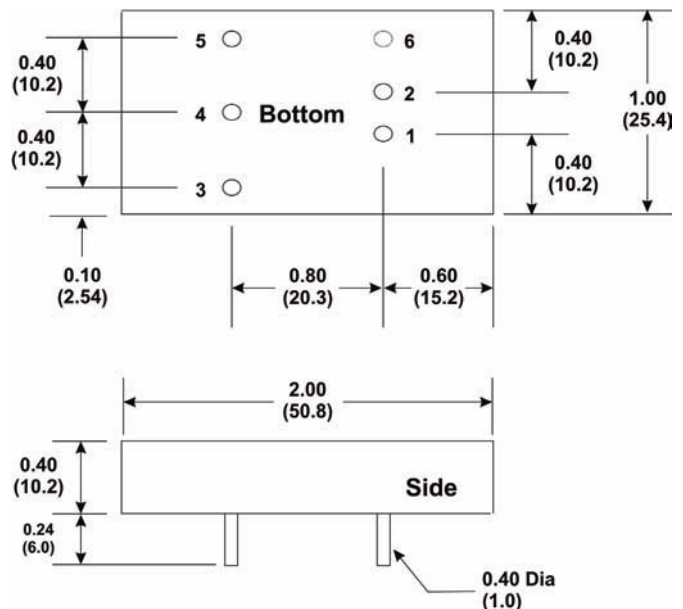

Mechanical Notes:

- All dimensions are typical in inches (mm)
- Tolerance x.xx = ±0.01 (±0.25)

Pin Connections

Pin	Single	Dual	Pin	Single	Dual
1	+Vin	+Vin	4	Trim	Common
2	-Vin	-Vin	5	-Vout	-Vout
3	+Vout	+Vout	6	Remote On/Off	Remote On/Off



MicroPower Direct

We Power Your Success - For Less!