

SINGLE CHANNEL PWM CONTROLLER WITH FEEDFORWARD AND 5V BIAS REGULATOR

ADVANCE DATA SHEET
Pb Free Product

DESCRIPTION

The NX2142/2142A controller IC is a compact synchronous Buck controller IC with 10 lead MSOP package designed for step down DC to DC converter applications with voltage feedforward functionality. Voltage feedforward provides fast response, good line regulation and nearly constant power stage gain under wide voltage input range. The NX2142/2142A controller is optimized to convert single supply up to 24V bus voltage to as low as 0.8V output voltage. NX2142/2142A can function as a single supply controller with its 5V bias regulator. Internal UVLO keeps the regulator off until the supply voltage exceeds 7V where internal digital soft start get initiated to ramp up output. The NX2142/2142A employs fixed current limiting and FB UVLO followed by hiccup feature. Other features includes: 5V gate drive capability, Converter Shutdown by pulling COMP pin to Gnd, Adaptive dead band control.

FEATURES

- Bus voltage operation from 7V to 24V
- 5V bias regulator available
- Excellent dynamic response with input voltage feed-forward and voltage mode control
- Fixed 600kHz, 1MHz switching frequency
- Internal Digital Soft Start Function
- Fixed internal hiccup current limit
- FB UVLO followed by hiccup feature
- Shutdown by pulling COMP pin low
- Pb-free and RoHS compliant

APPLICATIONS

- Graphic Card on board converters
- Vddq Supply in mother board applications
- On board DC to DC such as 12V to 3.3V, 2.5V or 1.8V
- Set Top Box and LCD Display

TYPICAL APPLICATION

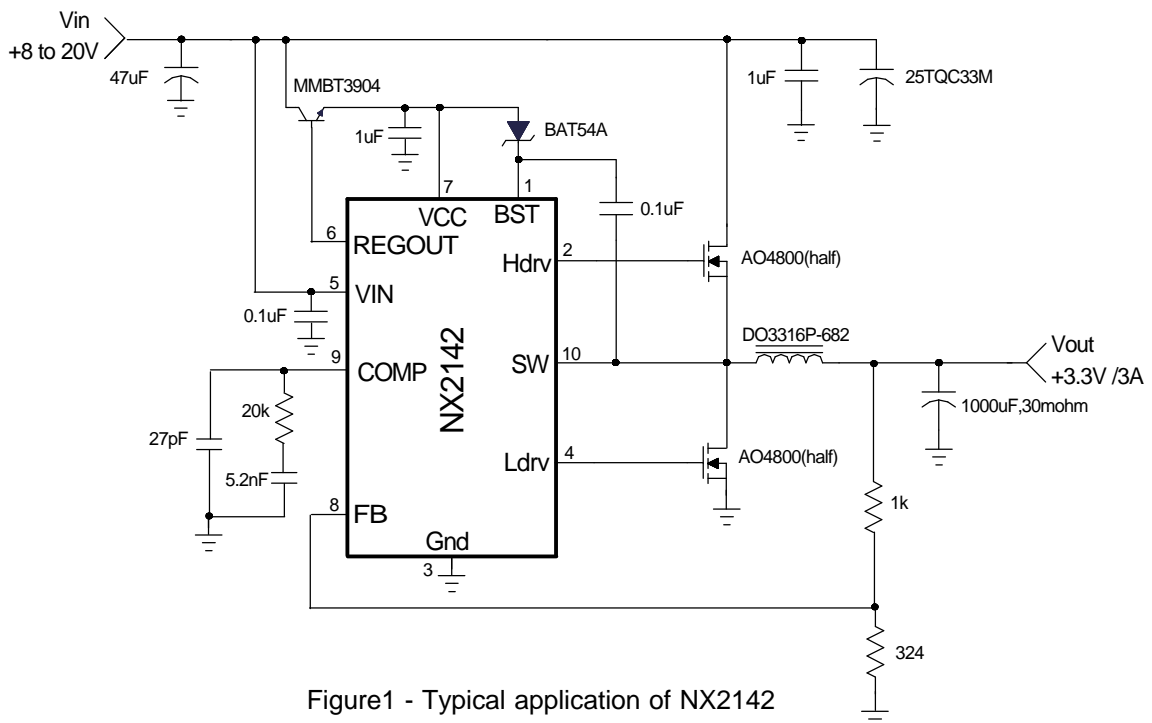

Figure1 - Typical application of NX2142

ORDERING INFORMATION

| Device | Temperature | Package | Frequency | Pb-Free |
|-------------|-------------|----------|-----------|---------|
| NX2142CUTR | 0 to 70° C | MSOP-10L | 600kHz | Yes |
| NX2142ACUTR | 0 to 70° C | MSOP-10L | 1MHz | Yes |

ABSOLUTE MAXIMUM RATINGS

| | |
|--------------------------------------------|----------------|
| VCC to GND & BST to SW voltage | -0.3V to 6.5V |
| VIN to GND | -0.3V to 30V |
| BST to GND Voltage | -0.3V to 35V |
| SW to GND | -2V to 35V |
| REGOUT to GND | 0.2 to 16V |
| All other pins | -0.3V to 6.5V |
| Storage Temperature Range | -65°C to 150°C |
| Operating Junction Temperature Range | -40°C to 125°C |
| ESD Susceptibility | 2kV |

CAUTION: Stresses above those listed in "ABSOLUTE MAXIMUM RATINGS", may cause permanent damage to the device. This is a stress only rating and operation of the device at these or any other conditions above those indicated in the operational sections of this specification is not implied.

PACKAGE INFORMATION

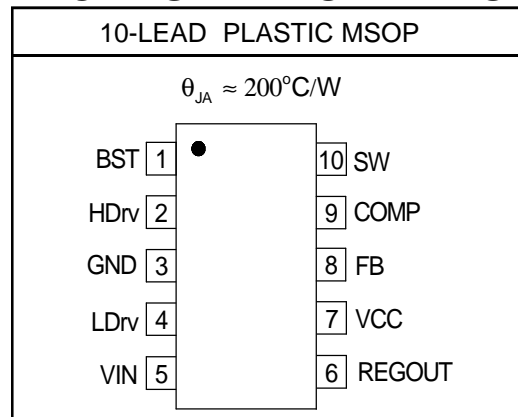

ELECTRICAL SPECIFICATIONS

Unless otherwise specified, these specifications apply over $V_{CC} = 5V$, $V_{IN} = 15V$ and $T_A = 0$ to 70°C . Typical values refer to $T_A = 25^{\circ}\text{C}$.

| PARAMETER | SYM | Test Condition | Min | TYP | MAX | Units |
|-----------------------------|----------------|------------------|-----|-----|-----|-------|
| Reference Voltage | | | | | | |
| Ref Voltage | V_{REF} | | | 0.8 | | V |
| Ref Voltage line regulation | | | | 0.2 | | % |
| Supply Voltage(Vcc) | | | | | | |
| V_{CC} Voltage Range | V_{CC} | | | 5 | | V |
| Operating quiescent current | I_Q | EN=HIGH | | 3 | | mA |
| Vcc UVLO | | | | | | |
| V_{CC} -Threshold | V_{CC_UVLO} | V_{CC} Rising | | 4.4 | | V |
| V_{CC} -Hysteresis | V_{CC_Hyst} | V_{CC} Falling | | 0.2 | | V |
| Supply Voltage(Vin) | | | | | | |
| V_{in} Voltage Range | V_{in} | | 7 | | 25 | V |
| Input Voltage Current | | $V_{in} = 24V$ | | 9 | | mA |
| Vin UVLO | | | | | | |
| V_{in} -Threshold | V_{in_UVLO} | V_{in} Rising | | 6 | | V |

| PARAMETER | SYM | Test Condition | Min | TYP | MAX | Units |
|----------------------------------------|----------------------------|-----------------------------------------------|-----|------|-----|-------|
| V _{in} -Hysteresis | V _{in-Hyst} | V _{in} Falling | | 0.5 | | V |
| Oscillator (Rt) | | | | | | |
| Frequency | F _S | NX2142 | | 600 | | KHz |
| | | NX2142A | | 1000 | | KHz |
| Frequency Over Vin | | | | 1 | | % |
| Ramp Peak to Peak Voltage | V _{RAMP} | V _{in} =20V | | 2 | | V |
| Ramp Valley Voltage | | | | 0.8 | | V |
| Ramp Peak to Peak/V _{in} Gain | | | | 0.1 | | V/V |
| Max Duty Cycle | | F _S =600kHz | | 77 | | % |
| Min Duty Cycle | | | | 0 | | % |
| Min Controllable on time | | | | | 150 | nS |
| Error Amplifiers | | | | | | |
| Transconductance | | | | 2500 | | umho |
| Input Bias Current | I _b | | | | 100 | nA |
| Comp SD threshold | | | | 0.3 | | V |
| Soft Start | | | | | | |
| Soft Start time | T _{ss} | NX2142 | | 3.4 | | mS |
| | | NX2142A | | 2 | | mS |
| High Side Driver (CL=3300pF) | | | | | | |
| Output Impedance , Sourcing Current | R _{source} (Hdrv) | I=200mA | | 1 | | ohm |
| Output Impedance , Sinking Current | R _{sink} (Hdrv) | I=200mA | | 0.8 | | ohm |
| Rise Time | T _{Hdrv} (Rise) | 10% to 90% | | 50 | | ns |
| Fall Time | T _{Hdrv} (Fall) | 90% to 10% | | 50 | | ns |
| Deadband Time | T _{dead} (L to H) | Ldrv going Low to Hdrv going High, 10% to 10% | | 30 | | ns |
| Low Side Driver (CL=3300pF) | | | | | | |
| Output Impedance, Sourcing Current | R _{source} (Ldrv) | I=200mA | | 1 | | ohm |
| Output Impedance, Sinking Current | R _{sink} (Ldrv) | I=200mA | | 0.5 | | ohm |
| Rise Time | T _{Ldrv} (Rise) | 10% to 90% | | 50 | | ns |
| Fall Time | T _{Ldrv} (Fall) | 90% to 10% | | 50 | | ns |
| Deadband Time | T _{dead} (H to L) | SW going Low to Ldrv going High, 10% to 10% | | 30 | | ns |
| Fixed OCP | | | | | | |
| OCP voltage threshold | | | | 320 | | mV |
| FBUVLO | | | | | | |
| Feedback UVLO threshold | | percent of nominal | | 70 | | % |
| Over temperature | | | | | | |
| Threshold | | | | 150 | | °C |
| Hysteresis | | | | 20 | | °C |

PIN DESCRIPTIONS

| PIN SYMBOL | PIN DESCRIPTION |
|------------|-------------------------------------------------------------------------------------------------------------------------------------------------------------------------------------------------------------------------------------------------------------------------------------------------------------------------------------------------------------------------------------|
| VCC | This pin supplies the internal 5V bias circuit. A 1uF high frequency ceramic X5R capacitor must be placed as close as possible to this pin and ground pin to provide high frequency bypass and to make the 5V regulator stable. |
| BST | This pin supplies voltage to high side FET driver. A minimum 0.1uF ceramic high frequency capacitor is placed as close as possible to and connected to this pin and SW pin. |
| GND | Power ground. |
| FB | This pin is the error amplifiers inverting input. It is connected via resistor divider to the output of the switching regulator to set the output DC voltage. |
| COMP | This pin is the output of the error amplifier and together with FB pin is used to compensate the voltage control feedback loop. You can shutdown the switching regulator by pulling this pin below 0.3V. |
| SW | This pin is connected to source of high side FETs and provides return path for the high side driver. This pin also provides input for the OCP comparator by sensing the RDSON of the lower MOSFET. When this pin is below ground by 320mV, both drivers are shutdown and enter hiccup mode. |
| HDRV | High side gate driver output. |
| LDRV | Low side gate driver output. |
| REGOUT | The output of the 5V regulator controller that drives a low current low cost external bipolar transistor or an external MOSFET to regulate the voltage at Vcc pin derived from bus voltage. This eliminates an otherwise external regulator needed in applications where 5V is not available. This regulator request a 1uF ceramic X5R type output capacitor in order to be stable. |
| VIN | This pin provides the input voltage to the 5V regulator controller as well as the oscillator for the PWM feed forward to work. When VIN exceeds 6V, the converter starts to operate. |

BLOCK DIAGRAM

Figure 2 - Simplified block diagram of the NX2142

TYPICAL APPLICATION CIRCUIT

Figure 3- Demo board schematic(VIN=8-20V,VOUT=5V,IOU=3A)

Bill of Materials

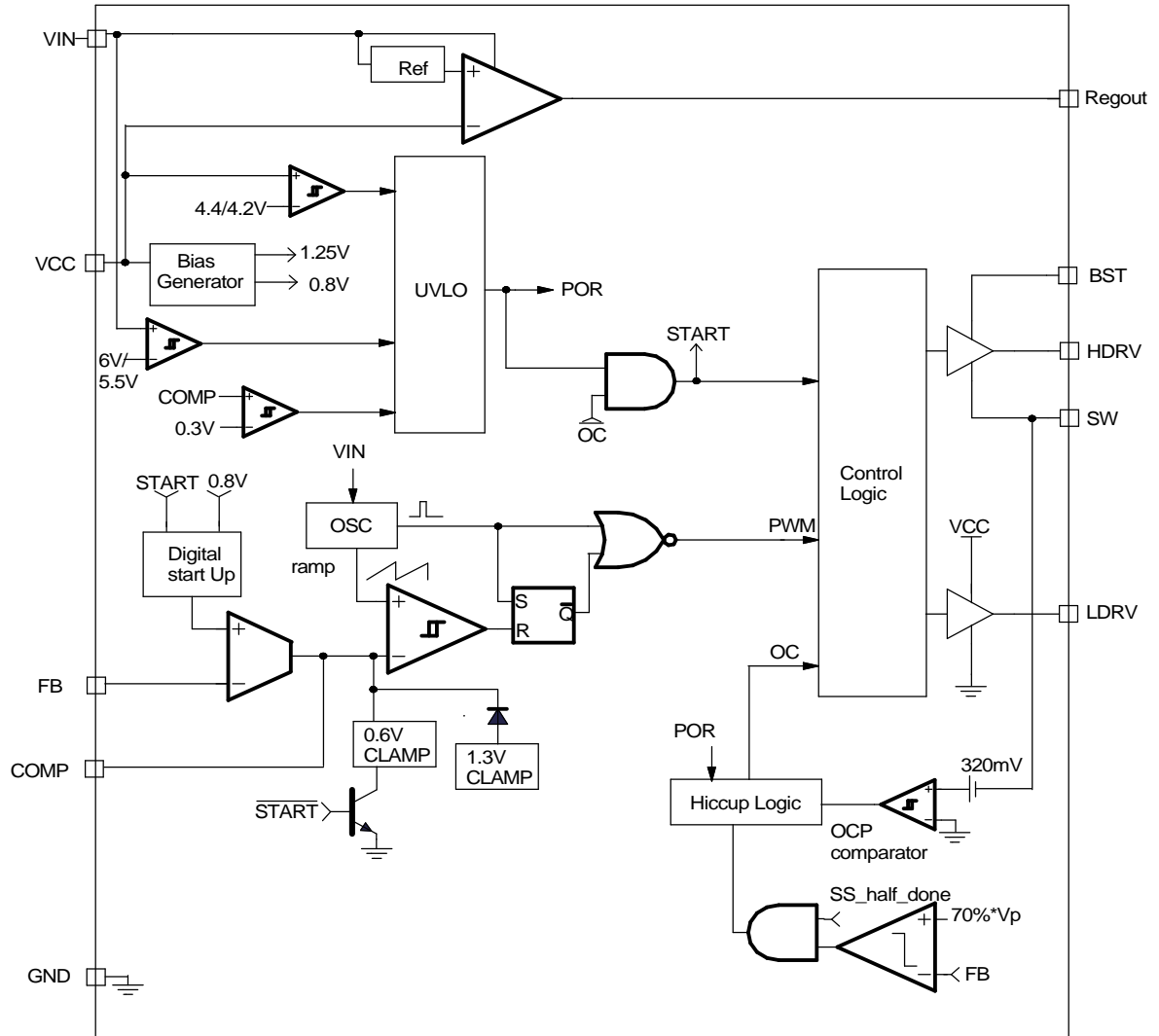
| Item | Quantity | Reference | Value | Manufacture |
|------|----------|-----------|-------------|-------------|
| 1 | 1 | Ci1 | 25TQC33M | SANYO |
| 2 | 1 | Co1 | 6MV1000WG | SANYO |
| 3 | 2 | C1,C6 | 0.1u | |
| 4 | 3 | C2,C14 | 1u | |
| 5 | 1 | C3 | 3.3n | |
| 6 | 1 | C4 | 52p | |
| 7 | 1 | C5 | 25n | |
| 8 | 1 | C9 | 470p | |
| 9 | 1 | C10 | 47u | |
| 10 | 1 | D1 | BAT54A | Fairchild |
| 11 | 1 | Lo | DO3316P-682 | Coilcraft |
| 12 | 2 | M5,M6 | AO4800 | AOS |
| 13 | 1 | Q1 | MMBT3904 | Fairchild |
| 14 | 1 | R7 | 10k | |
| 15 | 1 | R8 | 1.2k | |
| 16 | 1 | R9 | 4.99k 1% | |
| 17 | 1 | R10 | 953 1% | |
| 18 | 1 | R15 | 10 | |
| 19 | 1 | U1 | NX2142CUTR | NEXSEM INC. |

Demoboard waveforms

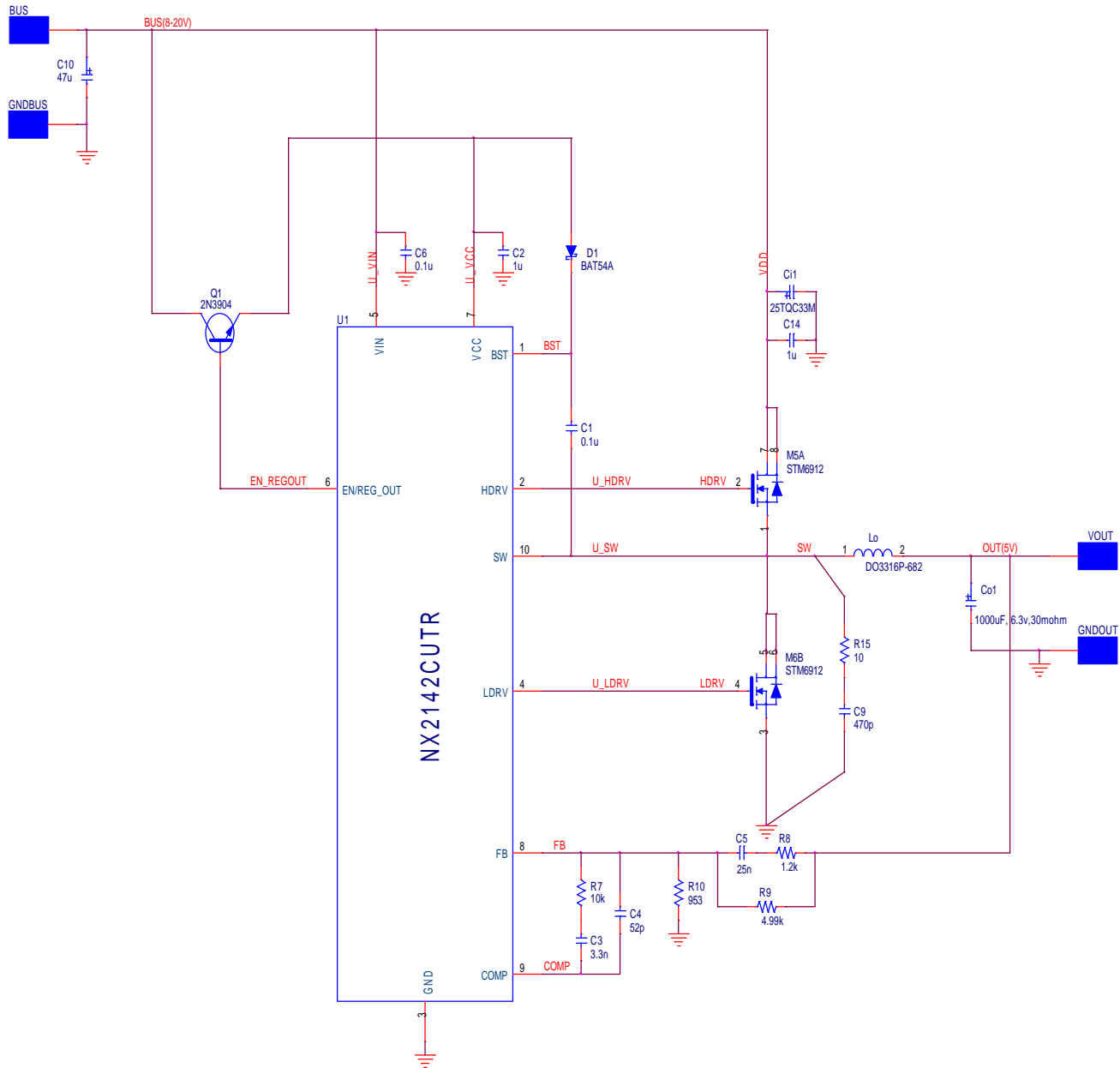
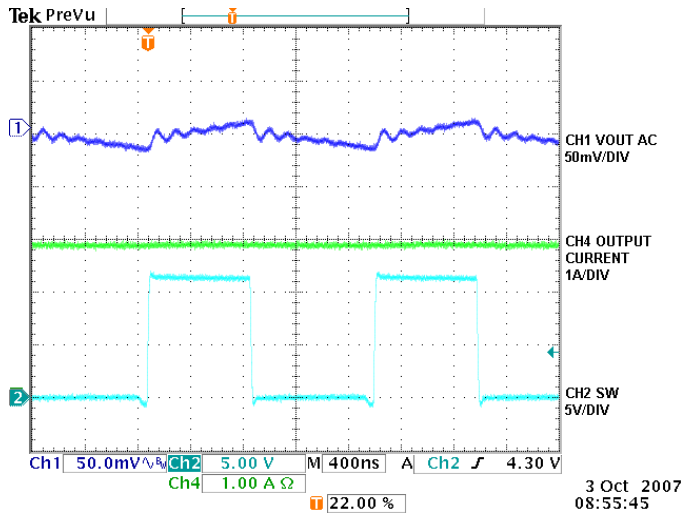
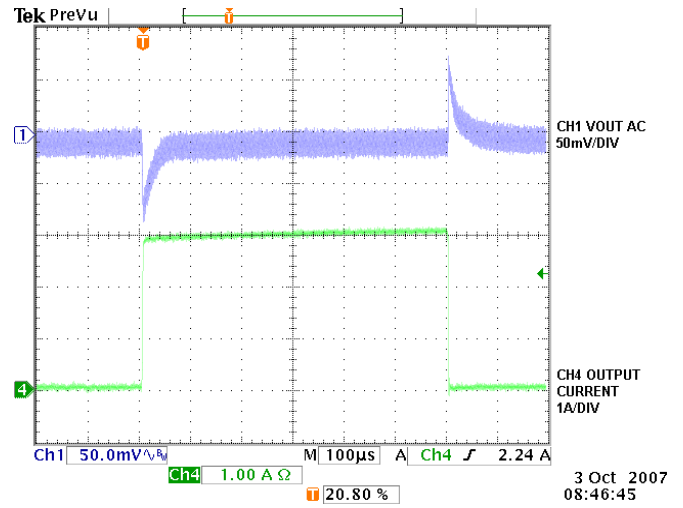
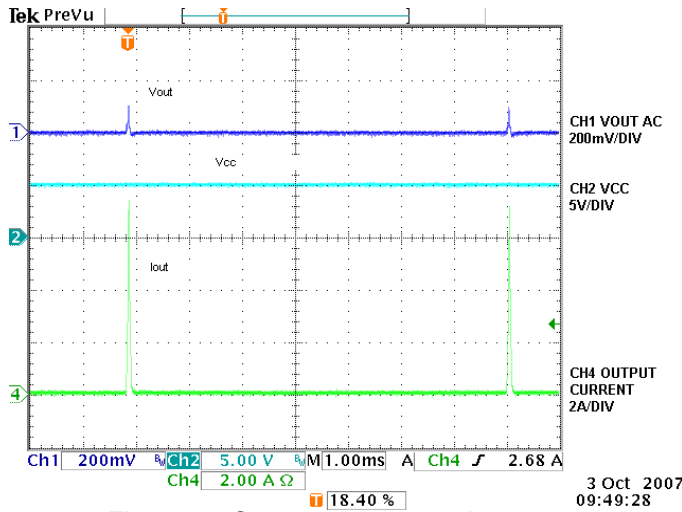
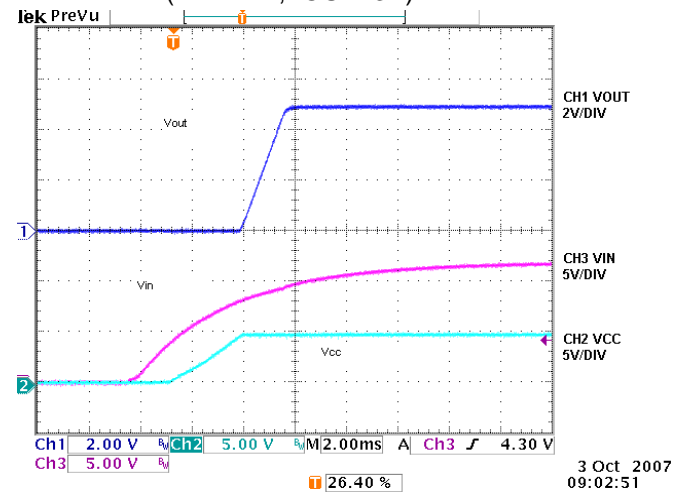
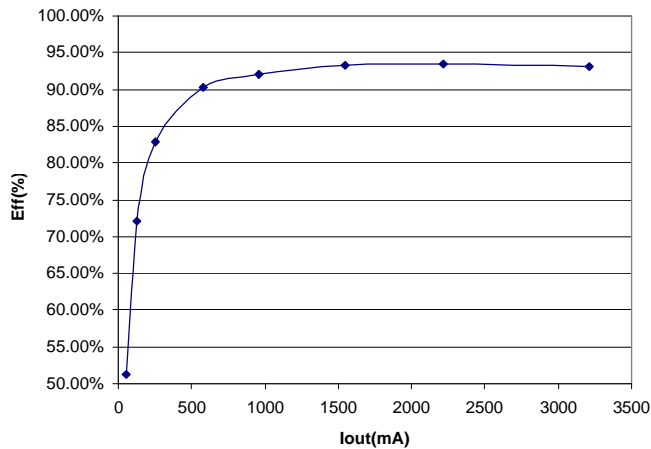
Figure 4 - Output ripple (VIN=12V)

Figure 5 - Output voltage transient response (VIN=12V, IOUT=3A)

Figure 6 - Over current protection

Figure 7 - Startup

Figure 8 - Output Efficiency (VIN=12V, VOUT=5V)

APPLICATION INFORMATION

Symbol Used In Application Information:

| | |
|---------------------|---------------------------|
| V_{IN} | - Input voltage |
| V_{OUT} | - Output voltage |
| I_{OUT} | - Output current |
| ΔV_{RIPPLE} | - Output voltage ripple |
| F_S | - Switching frequency |
| ΔI_{RIPPLE} | - Inductor current ripple |

Design Example

Power stage design requirements:

$$V_{INMIN}=8V$$

$$V_{INMAX}=20V$$

$$V_{OUT}=5V$$

$$I_{OUT}=3A$$

$$\Delta V_{RIPPLE} \leq 50mV$$

$$\Delta V_{TRAN} \leq 150mV \text{ @ } 1.5A \text{ step}$$

$$F_S=600kHz$$

Output Inductor Selection

The selection of inductor value is based on inductor ripple current, power rating, working frequency and efficiency. Larger inductor value normally means smaller ripple current. However if the inductance is chosen too large, it brings slow response and lower efficiency. Usually the ripple current ranges from 20% to 40% of the output current. This is a design freedom which can be decided by design engineer according to various application requirements. The inductor value can be calculated by using the following equations:

$$L_{OUT} = \frac{V_{INMAX} - V_{OUT}}{I_{RIPPLE}} \times \frac{V_{OUT}}{V_{INMAX}} \times \frac{1}{F_S} \quad \dots(1)$$

$$I_{RIPPLE} = k \times I_{OUTPUT}$$

where k is between 0.2 to 0.4.

Select k=0.3, then

$$L_{OUT} = \frac{20V-5V}{0.3 \times 3A} \times \frac{5V}{20V} \times \frac{1}{600kHz}$$

$$L_{OUT} = 6.9\mu H$$

Choose $L_{OUT}=6.8\mu H$, then coilcraft inductor

DO3316P-682HC is a good choice.

Current Ripple is calculated as

$$I_{RIPPLE} = \frac{V_{IN} - V_{OUT}}{L_{OUT}} \times \frac{V_{OUT}}{V_{IN}} \times \frac{1}{F_S} \\ = \frac{20V-5V}{6.8\mu H} \times \frac{5V}{20V} \times \frac{1}{600kHz} = 0.919A \quad \dots(2)$$

Output Capacitor Selection

Output capacitor is basically decided by the amount of the output voltage ripple allowed during steady state(DC) load condition as well as specification for the load transient. The optimum design may require a couple of iterations to satisfy both condition.

Based on DC Load Condition

The amount of voltage ripple during the DC load condition is determined by equation(3).

$$\Delta V_{RIPPLE} = ESR \times \Delta I_{RIPPLE} + \frac{\Delta I_{RIPPLE}}{8 \times F_S \times C_{OUT}} \quad \dots(3)$$

Where ESR is the output capacitors' equivalent series resistance, C_{OUT} is the value of output capacitors.

Typically when large value capacitors are selected such as Aluminum Electrolytic, POSCAP and OSCON types are used, the amount of the output voltage ripple is dominated by the first term in equation(3) and the second term can be neglected.

For this example, Aluminum Electrolytic is chosen as output capacitor, the ESR and inductor current typically determines the output voltage ripple.

$$ESR_{desire} = \frac{\Delta V_{RIPPLE}}{\Delta I_{RIPPLE}} = \frac{50mV}{0.919A} = 54m\Omega \quad \dots(4)$$

If low ESR is required, for most applications, multiple capacitors in parallel are better than a big capacitor. For example, for 50mV output ripple, Electrolytic 6ME1000WG with 30mΩ are chosen.

$$N = \frac{ESR_E \times \Delta I_{RIPPLE}}{\Delta V_{RIPPLE}} \quad \dots(5)$$

Number of Capacitor is calculated as

$$N = \frac{30m\Omega \times 0.919A}{50mV}$$

$$N = 0.55$$

The number of capacitor has to be round up to a integer. Choose $N = 1$.

If ceramic capacitors are chosen as output capacitors, both terms in equation (3) need to be evaluated to determine the overall ripple. Usually when this type of capacitors are selected, the amount of capacitance per single unit is not sufficient to meet the transient specification, which results in parallel configuration of multiple capacitors.

For example, one 100uF, X5R ceramic capacitor with 2mΩ ESR is used. The amount of output ripple is

$$\begin{aligned}\Delta V_{\text{RIPPLE}} &= 2\text{m}\Omega \times 0.919\text{A} + \frac{0.919\text{A}}{8 \times 600\text{kHz} \times 100\mu\text{F}} \\ &= 1.838\text{mV} + 1.9\text{mV} = 3.738\text{mV}\end{aligned}$$

One ceramic capacitors are needed. Although this can meet DC ripple spec, however it needs to be studied for transient requirement.

Based On Transient Requirement

Typically, the output voltage droop during transient is specified as

$$\Delta V_{\text{droop}} < \Delta V_{\text{tran}} @ \text{step load } \Delta I_{\text{STEP}}$$

During the transient, the voltage droop during the transient is composed of two sections. One section is dependent on the ESR of capacitor, the other section is

a function of the inductor, output capacitance as well as input, output voltage. For example, for the overshoot when load from high load to light load with a ΔI_{STEP} transient load, if assuming the bandwidth of system is high enough, the overshoot can be estimated as the following equation.

$$\Delta V_{\text{overshoot}} = \text{ESR} \times \Delta I_{\text{step}} + \frac{V_{\text{OUT}}}{2 \times L \times C_{\text{OUT}}} \times \tau^2 \quad \dots(6)$$

where τ is the a function of capacitor, etc.

$$\tau = \begin{cases} 0 & \text{if } L \leq L_{\text{crit}} \\ \frac{L \times \Delta I_{\text{step}}}{V_{\text{OUT}}} - \text{ESR} \times C_{\text{OUT}} & \text{if } L \geq L_{\text{crit}} \end{cases} \quad \dots(7)$$

where

$$L_{\text{crit}} = \frac{\text{ESR} \times C_{\text{OUT}} \times V_{\text{OUT}}}{\Delta I_{\text{step}}} = \frac{\text{ESR}_E \times C_E \times V_{\text{OUT}}}{\Delta I_{\text{step}}} \quad \dots(8)$$

where ESR_E and C_E represents ESR and capaci-

tance of each capacitor if multiple capacitors are used in parallel.

The above equation shows that if the selected output inductor is smaller than the critical inductance, the voltage droop or overshoot is only dependent on the ESR of output capacitor. For low frequency capacitor such as electrolytic capacitor, the product of ESR and capacitance is high and $L \leq L_{\text{crit}}$ is true. In that case, the transient spec is mostly like to dependent on the ESR of capacitor.

Most case, the output capacitor is multiple capacitor in parallel. The number of capacitor can be calculated by the following

$$N = \frac{\text{ESR}_E \times \Delta I_{\text{step}}}{\Delta V_{\text{tran}}} + \frac{V_{\text{OUT}}}{2 \times L \times C_E \times \Delta V_{\text{tran}}} \times \tau^2 \quad \dots(9)$$

where

$$\tau = \begin{cases} 0 & \text{if } L \leq L_{\text{crit}} \\ \frac{L \times \Delta I_{\text{step}}}{V_{\text{OUT}}} - \text{ESR}_E \times C_E & \text{if } L \geq L_{\text{crit}} \end{cases} \quad \dots(10)$$

For example, assume voltage droop during transient is 150mV for 1.5A load step.

If the Electrolytic 6ME1000WG(1000uF, 30mohm ESR) is used, the critical inductance is given as

$$\begin{aligned}L_{\text{crit}} &= \frac{\text{ESR}_E \times C_E \times V_{\text{OUT}}}{\Delta I_{\text{step}}} \\ &= \frac{30\text{m}\Omega \times 1000\mu\text{F} \times 5\text{V}}{1.5\text{A}} = 100\mu\text{H}\end{aligned}$$

The selected inductor is 6.8uH which is much smaller than critical inductance. In that case, the output voltage transient not only dependent on the ESR, but also capacitance.

number of capacitor is

$$\begin{aligned}N &= \frac{\text{ESR}_E \times \Delta I_{\text{step}}}{\Delta V_{\text{tran}}} \\ &= \frac{30\text{m}\Omega \times 1.5\text{A}}{200\text{mV}} \\ &= 0.225\end{aligned}$$

The number of capacitors has to satisfy both ripple and transient requirement. Overall, we choose $N=1$.

It should be considered that the proposed equation is based on ideal case, in reality, the droop or overshoot is typically more than the calculation. The equation gives a good start. For more margin, more capacitors have to be chosen after the test. Typically, for high frequency capacitor such as high quality POSCAP especially ceramic capacitor, 20% to 100% (for ceramic) more capacitors have to be chosen since the ESR of capacitors is so low that the PCB parasitic can affect the results tremendously. More capacitors have to be selected to compensate these parasitic parameters.

Compensator Design

Due to the double pole generated by LC filter of the power stage, the power system has 180° phase shift, and therefore, is unstable by itself. In order to achieve accurate output voltage and fast transient response, compensator is employed to provide highest possible bandwidth and enough phase margin. Ideally, the Bode plot of the closed loop system has crossover frequency between 1/10 and 1/5 of the switching frequency, phase margin greater than 50° and the gain crossing 0dB with -20dB/decade. Power stage output capacitors usually decide the compensator type. If electrolytic capacitors are chosen as output capacitors, type II compensator can be used to compensate the system, because the zero caused by output capacitor ESR is lower than crossover frequency. Otherwise type III compensator should be chosen.

Voltage feedforward compensation is used in NX2142 to compensate the output voltage variation caused by input voltage changing. The feedforward function is realized by using VIN pin voltage to program the oscillator ramp voltage V_{OSC} at about 1/10 of V_{IN} voltage, which provides nearly constant power stage gain under wide voltage input range.

A. Type III compensator design

For low ESR output capacitors, typically such as Sanyo oscap and poscap, the frequency of ESR zero caused by output capacitors is higher than the crossover frequency. In this case, it is necessary to compensate the system with type III compensator. The

following figures and equations show how to realize the type III compensator by transconductance amplifier.

$$F_{Z1} = \frac{1}{2 \times \pi \times R_4 \times C_2} \quad \dots(11)$$

$$F_{Z2} = \frac{1}{2 \times \pi \times (R_2 + R_3) \times C_3} \quad \dots(12)$$

$$F_{P1} = \frac{1}{2 \times \pi \times R_3 \times C_3} \quad \dots(13)$$

$$F_{P2} = \frac{1}{2 \times \pi \times R_4 \times \frac{C_1 \times C_2}{C_1 + C_2}} \quad \dots(14)$$

where F_{Z1}, F_{Z2}, F_{P1} and F_{P2} are poles and zeros in the compensator.

The transfer function of type III compensator for transconductance amplifier is given by:

$$\frac{V_e}{V_{OUT}} = \frac{1 - g_m \times Z_f}{1 + g_m \times Z_{in} + Z_{in} / R_1}$$

For the voltage amplifier, the transfer function of compensator is

$$\frac{V_e}{V_{OUT}} = \frac{-Z_f}{Z_{in}}$$

To achieve the same effect as voltage amplifier, the compensator of transconductance amplifier must satisfy this condition: $R_4 \gg 2/g_m$. And it would be desirable if $R_1 || R_2 || R_3 \gg 1/g_m$ can be met at the same time,

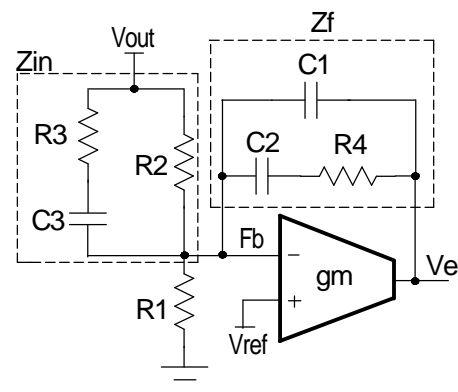

Figure 9 - Type III compensator using transconductance amplifier

Case 1: $F_{LC} < F_O < F_{ESR}$ (for most ceramic or low ESR POSCAP, OSCON)

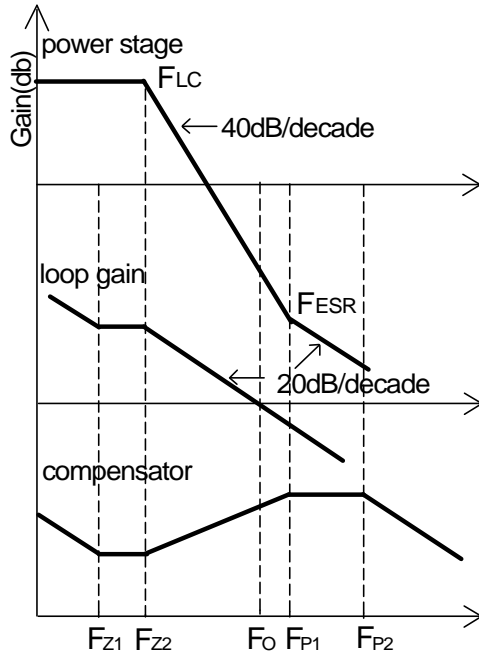

Figure 10 - Bode plot of Type III compensator ($F_{LC} < F_O < F_{ESR}$)

Typical design example of type III compensator in which the crossover frequency is selected as $F_{LC} < F_O < F_{ESR}$ and $F_O \leq 1/10 \sim 1/5 F_s$ is shown as the following steps. Here two X5R 22uF ceramic capacitor with 3mΩ is chosen as output capacitor, output inductor is 6.8uH.

1. Calculate the location of LC double pole F_{LC} and ESR zero F_{ESR} .

$$F_{LC} = \frac{1}{2 \times \pi \times \sqrt{L_{OUT} \times C_{OUT}}} = \frac{1}{2 \times \pi \times \sqrt{6.8\mu H \times 44\mu F}} = 9.2\text{kHz}$$

$$F_{ESR} = \frac{1}{2 \times \pi \times ESR \times C_{OUT}} = \frac{1}{2 \times \pi \times 1.5\text{m}\Omega \times 44\mu F} = 241\text{kHz}$$

2. Set R_4 equal to 10kΩ.

3. Calculate C_2 with zero F_{z1} at 50% of the LC double pole by equation (11).

$$C_2 = \frac{1}{2 \times \pi \times F_{z1} \times R_4} = \frac{1}{2 \times \pi \times 0.5 \times 9.2\text{kHz} \times 10\text{k}\Omega} = 3.5\text{nF}$$

Choose $C_2 = 3.9\text{nF}$.

4. Calculate C_1 by equation (14) with pole F_{p2} at half the switching frequency.

$$C_1 = \frac{1}{2 \times \pi \times R_4 \times F_{p2}} = \frac{1}{2 \times \pi \times 10\text{k}\Omega \times 300\text{kHz}} = 53\text{pF}$$

Choose $C_1 = 52\text{pF}$.

5. Calculate C_3 with the crossover frequency at 1/10~ 1/5 of the switching frequency. Set $F_O = 60\text{kHz}$.

$$C_3 = \frac{V_{OSC}}{V_{in}} \times \frac{2 \times \pi \times F_O \times L}{R_4} \times C_{out} = \frac{1}{10} \times \frac{2 \times \pi \times 60\text{kHz} \times 6.8\mu H}{10\text{k}\Omega} \times 44\mu F = 1.1\text{nF}$$

Choose $C_3 = 1.2\text{nF}$.

6. Set zero $F_{z2} = 0.75 F_{LC}$ and $F_{p1} = 0.5 F_s$, calculate R_2 .

$$R_2 = \frac{1}{2 \times \pi \times C_3} \times \left(\frac{1}{F_{z2}} - \frac{1}{F_{p1}} \right) = \frac{1}{2 \times \pi \times 1.2\text{nF}} \times \left(\frac{1}{0.75 \times 9.2\text{kHz}} - \frac{1}{300\text{kHz}} \right) = 18\text{k}\Omega$$

Choose $R_2 = 20\text{k}\Omega$.

7. Calculate R_3 by equation (13) with $F_{p1} = F_s$.

$$R_3 = \frac{1}{2 \times \pi \times F_{p1} \times C_3} = \frac{1}{2 \times \pi \times 600\text{kHz} \times 1.2\text{nF}} = 221\Omega$$

Choose $R_3 = 300\Omega$.

8. Calculate R_1 .

$$R_1 = \frac{R_2 \times V_{REF}}{V_{OUT} - V_{REF}} = \frac{20k\Omega \times 0.8V}{5V - 0.8V} = 5.7k\Omega$$

Choose $R_1 = 5.7k\Omega$.

Case 2: $F_{LC} < F_{ESR} < F_O$ (for electrolytic capacitors)

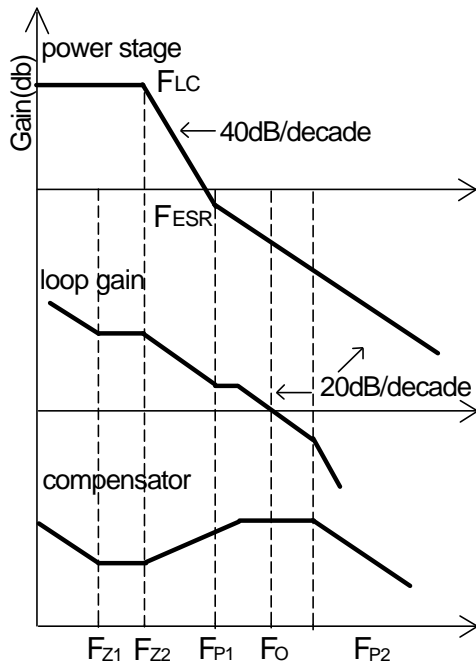

Figure 11 - Bode plot of Type III compensator ($F_{LC} < F_{ESR} < F_O$)

If electrolytic capacitors are used as output capacitors, typical design example of type III compensator in which the crossover frequency is selected as $F_{LC} < F_{ESR} < F_O$ and $F_O \leq 1/10 \sim 1/5 F_s$ is shown as the following steps. Here one SANYO 6ME-WG1000 with 30 m Ω is chosen as output capacitor, output inductor is 6.8 μ H.

1. Calculate the location of LC double pole F_{LC} and ESR zero F_{ESR} .

$$F_{LC} = \frac{1}{2 \times \pi \times \sqrt{L_{OUT} \times C_{OUT}}} = \frac{1}{2 \times \pi \times \sqrt{6.8\mu H \times 1000\mu F}} = 1.93kHz$$

$$F_{ESR} = \frac{1}{2 \times \pi \times ESR \times C_{OUT}} = \frac{1}{2 \times \pi \times 30m\Omega \times 1000\mu F} = 5.3kHz$$

2. Set R_4 equal to 10k Ω .

3. Calculate C_2 with zero F_{z1} at 75% of the LC double pole by equation (11).

$$C_2 = \frac{1}{2 \times \pi \times F_{z1} \times R_4} = \frac{1}{2 \times \pi \times 0.75 \times 1.93kHz \times 10k\Omega} = 10nF$$

Choose $C_2 = 10nF$.

4. Calculate C_1 by equation (14) with pole F_{p2} at half the switching frequency.

$$C_1 = \frac{1}{2 \times \pi \times R_4 \times F_{p2}} = \frac{1}{2 \times \pi \times 10k\Omega \times 300kHz} = 53pF$$

Choose $C_1 = 52pF$.

5. Calculate C_3 with the crossover frequency at 1/10~ 1/5 of the switching frequency. Set $F_O = 60kHz$.

$$C_3 = \frac{V_{OSC}}{V_{in}} \times \frac{F_O \times L}{ESR \times R_4 \times F_{p1}} = \frac{1}{10} \times \frac{60kHz \times 6.8\mu H}{30m\Omega \times 10k\Omega \times 5.3kHz} = 25nF$$

Choose $C_3 = 25nF$.

6. Set zero $F_{z2} = F_{LC}$ and $F_{p1} = F_{ESR}$, calculate R_2 .

$$R_2 = \frac{1}{2 \times \pi \times C_3} \times \left(\frac{1}{F_{z2}} - \frac{1}{F_{p1}} \right) = \frac{1}{2 \times \pi \times 25nF} \times \left(\frac{1}{1.93kHz} - \frac{1}{5.3kHz} \right) = 2k\Omega$$

Choose $R_2 = 20k\Omega$.

7. Calculate R_3 by equation (13) with $F_{p1} = F_{ESR}$.

$$R_3 = \frac{1}{2 \times \pi \times F_{p1} \times C_3}$$

$$= \frac{1}{2 \times \pi \times 5.3\text{kHz} \times 25\text{nF}}$$

$$= 1.2\text{k}\Omega$$

Choose $R_3 = 1.2\text{k}\Omega$.

8. Calculate R_1 .

$$R_1 = \frac{R_2 \times V_{REF}}{V_{OUT} - V_{REF}} = \frac{1.2\text{k}\Omega \times 0.8\text{V}}{5\text{V} - 0.8\text{V}} = 381\Omega$$

Choose $R_1 = 381\Omega$.

B. Type II compensator design

If the electrolytic capacitors are chosen as power stage output capacitors, usually the Type II compensator can be used to compensate the system.

For this type of compensator, F_o has to satisfy $F_{LC} < F_{ESR} \ll F_o \ll 1/10 \sim 1/5 F_s$.

Case 1:

Type II compensator can be realized by simple RC circuit as shown in figure 13. R_3 and C_1 introduce a zero to cancel the double pole effect. C_2 introduces a pole to suppress the switching noise.

To achieve the same effect as voltage amplifier, the compensator of transconductance amplifier must satisfy this condition: $R_3 \gg 1/g_m$ and $R_1 || R_2 \gg 1/g_m$. The following equations show the compensator pole zero location and constant gain.

$$\text{Gain} = \frac{R_3}{R_2} \quad \dots (15)$$

$$F_z = \frac{1}{2 \times \pi \times R_3 \times C_1} \quad \dots (16)$$

$$F_p \approx \frac{1}{2 \times \pi \times R_3 \times C_2} \quad \dots (17)$$

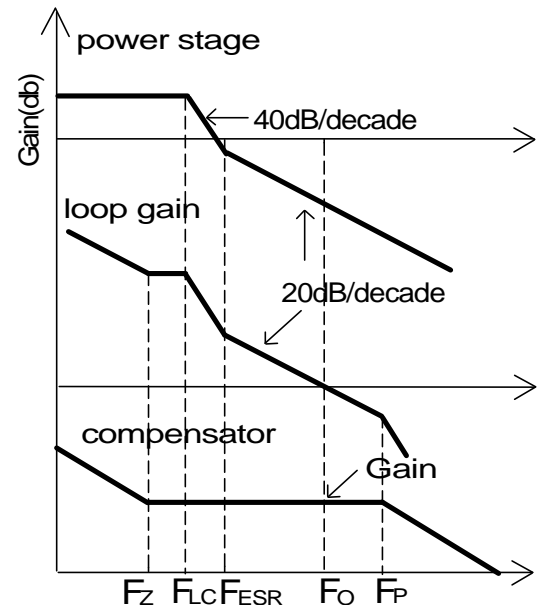

Figure 12 - Bode plot of Type II compensator

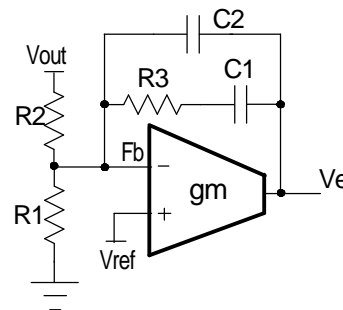

Figure 13 - Type II compensator with transconductance amplifier(case 1)

The following parameters are used as an example for type II compensator design, three 1500uF with 19mohm Sanyo electrolytic CAP 6MV1500WGL are used as output capacitors. Coilcraft DO5010P-152HC 1.5uH is used as output inductor. The power stage information is that: $V_{IN} = 12\text{V}$, $V_{OUT} = 1.2\text{V}$, $I_{OUT} = 12\text{A}$, $F_s = 600\text{kHz}$.

1. Calculate the location of LC double pole F_{LC} and ESR zero F_{ESR} .

$$F_{LC} = \frac{1}{2 \times \pi \times \sqrt{L_{OUT} \times C_{OUT}}}$$

$$= \frac{1}{2 \times \pi \times \sqrt{1.5\mu H \times 4500\mu F}}$$

$$= 1.94\text{kHz}$$

$$F_{ESR} = \frac{1}{2 \times \pi \times ESR \times C_{OUT}}$$

$$= \frac{1}{2 \times \pi \times 6.33\text{m}\Omega \times 4500\mu F}$$

$$= 5.6\text{kHz}$$

2. Set crossover frequency $F_o = 60\text{kHz} \gg F_{ESR}$.

3. Set R_2 equal to $4\text{k}\Omega$. Based on output voltage, using equation 21, the final selection of R_1 is $8\text{k}\Omega$.

4. Calculate R_3 value by the following equation.

$$R_3 = \frac{V_{OSC}}{V_{in}} \times \frac{2 \times \pi \times F_o \times L}{ESR} \times R_2$$

$$= \frac{1}{10} \times \frac{2 \times \pi \times 60\text{kHz} \times 1.5\mu H}{6.33\text{m}\Omega} \times 4\text{k}\Omega$$

$$= 36\text{k}\Omega$$

Choose $R_3 = 37.4\text{k}\Omega$.

5. Calculate C_1 by setting compensator zero F_z at 75% of the LC double pole.

$$C_1 = \frac{1}{2 \times \pi \times R_3 \times F_z}$$

$$= \frac{1}{2 \times \pi \times 37.4\text{k}\Omega \times 0.75 \times 1.94\text{kHz}}$$

$$= 2.7\text{nF}$$

Choose $C_1 = 2.7\text{nF}$.

6. Calculate C_2 by setting compensator pole F_p at half the switching frequency.

$$C_2 = \frac{1}{\pi \times R_3 \times F_s}$$

$$= \frac{1}{\pi \times 37.4\text{k}\Omega \times 600\text{kHz}}$$

$$= 14\text{pF}$$

Choose $C_2 = 15\text{pF}$.

Case 2:

Type II compensator can also be realized by simple RC circuit without feedback as shown in figure 15. R_3 and C_1 introduce a zero to cancel the double pole effect. C_2 introduces a pole to suppress the switching noise. The following equations show the compensator pole zero location and constant gain.

$$\text{Gain} = g_m \times \frac{R_1}{R_1 + R_2} \times R_3 \quad \dots (18)$$

$$F_z = \frac{1}{2 \times \pi \times R_3 \times C_1} \quad \dots (19)$$

$$F_p \approx \frac{1}{2 \times \pi \times R_3 \times C_2} \quad \dots (20)$$

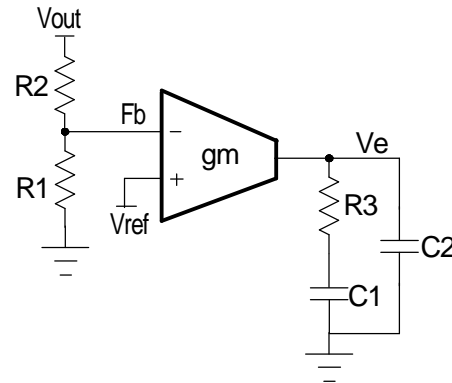

Figure 14 - Type II compensator with transconductance amplifier (case 2)

The following is parameters for type II compensator design. Input voltage is 12V, output voltage is 2.5V, output inductor is 2.2uH, output capacitors are two 680uF with 41mΩ electrolytic capacitors.

1. Calculate the location of LC double pole F_{LC} and ESR zero F_{ESR} .

$$F_{LC} = \frac{1}{2 \times \pi \times \sqrt{L_{OUT} \times C_{OUT}}}$$

$$= \frac{1}{2 \times \pi \times \sqrt{2.2\mu H \times 1360\mu F}}$$

$$= 2.9\text{kHz}$$

$$\begin{aligned}
 F_{ESR} &= \frac{1}{2 \times \pi \times ESR \times C_{OUT}} \\
 &= \frac{1}{2 \times \pi \times 20.5m\Omega \times 1360\mu F} \\
 &= 5.7kHz
 \end{aligned}$$

2. Set R_2 equal to 10k Ω . Using equation 18, the final selection of R_1 is 4.7k Ω .

3. Set crossover frequency at 1/10~ 1/5 of the swithing frequency, here $F_o=60kHz$.

4. Calculate R_3 value by the following equation.

$$\begin{aligned}
 R_3 &= \frac{V_{OSC}}{V_{in}} \times \frac{2 \times \pi \times F_o \times L}{R_{ESR}} \times \frac{1}{g_m} \times \frac{V_{OUT}}{V_{REF}} \\
 &= \frac{1}{10} \times \frac{2 \times \pi \times 60kHz \times 2.2\mu H}{20.5m\Omega} \times \frac{1}{2.5mA/V} \\
 &\quad \times \frac{2.5V}{0.8V} \\
 &= 5k\Omega
 \end{aligned}$$

Choose $R_3=5k\Omega$.

5. Calculate C_1 by setting compensator zero F_z at 75% of the LC double pole.

$$\begin{aligned}
 C_1 &= \frac{1}{2 \times \pi \times R_3 \times F_z} \\
 &= \frac{1}{2 \times \pi \times 5k\Omega \times 0.75 \times 2.9kHz} \\
 &= 14nF
 \end{aligned}$$

Choose $C_1=15nF$.

6. Calculate C_2 by setting compensator pole F_p at half the swithing frequency.

$$\begin{aligned}
 C_2 &= \frac{1}{\pi \times R_3 \times F_s} \\
 &= \frac{1}{\pi \times 5k\Omega \times 600kHz} \\
 &= 54pF
 \end{aligned}$$

Choose $C_2=52pF$.

Output Voltage Calculation

Output voltage is set by reference voltage and external voltage divider. The reference voltage is fixed at 0.8V. The divider consists of two ratioed resistors so that the output voltage applied at the Fb pin is 0.8V when the output voltage is at the desired value. The following equation applies to figure 15, which shows the relationship between V_{OUT} , V_{REF} and voltage divider.

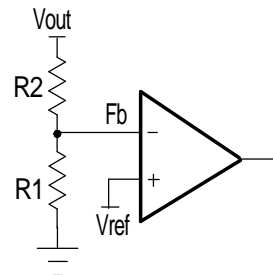

Figure 15 - Voltage divider

$$R_1 = \frac{R_2 \times V_{REF}}{V_{OUT} - V_{REF}} \quad \dots(21)$$

where R_2 is part of the compensator, and the value of R_1 value can be set by voltage divider.

Input Capacitor Selection

Input capacitors are usually a mix of high frequency ceramic capacitors and bulk capacitors. Ceramic capacitors bypass the high frequency noise, and bulk capacitors supply switching current to the MOSFETs. Usually 1 μF ceramic capacitor is chosen to decouple the high frequency noise. The bulk input capacitors are decided by voltage rating and RMS current rating. The RMS current in the input capacitors can be calculated as:

$$\begin{aligned}
 I_{RMS} &= I_{OUT} \times \sqrt{D} \times \sqrt{1-D} \\
 D &= \frac{V_{OUT}}{V_{INMIN}} \quad \dots(22)
 \end{aligned}$$

$V_{INMIN} = 8V$, $V_{OUT}=1.05V$, $I_{OUT}=10A$, the result of input RMS current is 3.4A.

For higher efficiency, low ESR capacitors are recommended. One Sanyo OSCON CAP 25SVP56M

25V 56uF 28mΩ with 3.8A RMS rating are chosen as input bulk capacitors.

Power MOSFETs Selection

The NX2142 requires two N-Channel power MOSFETs. The selection of MOSFETs is based on maximum drain source voltage, gate source voltage, maximum current rating, MOSFET on resistance and power dissipation. The main consideration is the power loss contribution of MOSFETs to the overall converter efficiency. In this design example, two STM6912 are used. They have the following parameters: $V_{DS}=30V$, $I_D=6A$, $R_{DS(ON)}=57m\Omega$, $Q_{GATE}=6.3nC$.

There are two factors causing the MOSFET power loss: conduction loss, switching loss.

Conduction loss is simply defined as:

$$\begin{aligned} P_{HCON} &= I_{OUT}^2 \times D \times R_{DS(ON)} \times K \\ P_{LCON} &= I_{OUT}^2 \times (1-D) \times R_{DS(ON)} \times K \\ P_{TOTAL} &= P_{HCON} + P_{LCON} \end{aligned} \quad \dots(23)$$

where the $R_{DS(ON)}$ will increase as MOSFET junction temperature increases, K is $R_{DS(ON)}$ temperature dependency. As a result, $R_{DS(ON)}$ should be selected for the worst case, in which K approximately equals to 1.4 at 125°C according to datasheet. Conduction loss should not exceed package rating or overall system thermal budget.

Switching loss is mainly caused by crossover conduction at the switching transition. The total switching loss can be approximated.

$$P_{SW} = \frac{1}{2} \times V_{IN} \times I_{OUT} \times T_{SW} \times F_s \quad \dots(24)$$

where I_{OUT} is output current, T_{SW} is the sum of T_R and T_F which can be found in mosfet datasheet, and F_s is switching frequency. Switching loss P_{SW} is frequency dependent.

Also MOSFET gate driver loss should be considered when choosing the proper power MOSFET. MOSFET gate driver loss is the loss generated by discharging the gate capacitor and is dissipated in driver circuits. It is proportional to frequency and is defined as:

$$P_{gate} = (Q_{HGATE} \times V_{HGS} + Q_{LGATE} \times V_{LGS}) \times F_s \quad \dots(25)$$

where Q_{HGATE} is the high side MOSFETs gate charge, Q_{LGATE} is the low side MOSFETs gate charge, V_{HGS}

is the high side gate source voltage, and V_{LGS} is the low side gate source voltage.

This power dissipation should not exceed maximum power dissipation of the driver device.

Over Current Limit Protection

Over current Limit for step down converter is achieved by sensing current through the low side MOSFET. For NX2142, the current limit is decided by the $R_{DS(ON)}$ of the low side mosfet. When synchronous FET is on, and the voltage on SW pin is below 320mV, the over current occurs. The over current limit can be calculated by the following equation.

$$I_{SET} = 320mV / R_{DS(ON)}$$

The MOSFET $R_{DS(ON)}$ is calculated in the worst case situation, then the current limit for MOSFET STM6912 is

$$I_{SET} = \frac{320mV}{R_{DS(ON)}} = \frac{320mV}{1.2 \times 57m\Omega} = 4.6A$$

Layout Considerations

The layout is very important when designing high frequency switching converters. Layout will affect noise pickup and can cause a good design to perform with less than expected results.

There are two sets of components considered in the layout which are power components and small signal components. Power components usually consist of input capacitors, high-side MOSFET, low-side MOSFET, inductor and output capacitors. A noisy environment is generated by the power components due to the switching power. Small signal components are connected to sensitive pins or nodes. A multilayer layout which includes power plane, ground plane and signal plane is recommended.

Layout guidelines:

1. First put all the power components in the top layer connected by wide, copper filled areas. The input capacitor, inductor, output capacitor and the MOSFETs should be close to each other as possible. This helps

to reduce the EMI radiated by the power loop due to the high switching currents through them.

2. Low ESR capacitor which can handle input RMS ripple current and a high frequency decoupling ceramic cap which usually is 1uF need to be practically touching the drain pin of the upper MOSFET, a plane connection is a must.

3. The output capacitors should be placed as close as to the load as possible and plane connection is required.

4. Drain of the low-side MOSFET and source of the high-side MOSFET need to be connected thru a plane and as close as possible. A snubber needs to be placed as close to this junction as possible.

5. Source of the lower MOSFET needs to be connected to the GND plane with multiple vias. One is not enough. This is very important. The same applies to the output capacitors and input capacitors.

6. Hdrv and Ldrv pins should be as close to MOSFET gate as possible. The gate traces should be wide and short. A place for gate drv resistors is needed to fine tune noise if needed.

7. Vcc capacitor, BST capacitor or any other bypassing capacitor needs to be placed first around the IC and as close as possible. The capacitor on comp to GND or comp back to FB needs to be placed as close to the pin as well as resistor divider.

8. The output sense line which is sensing output back to the resistor divider should not go through high frequency signals.

9. All GNDs need to go directly thru via to GND plane.

10. The feedback part of the system should be kept away from the inductor and other noise sources, and be placed close to the IC.

11. In multilayer PCB, separate power ground and analog ground. These two grounds must be connected together on the PC board layout at a single point. The goal is to localize the high current path to a separate loop that does not interfere with the more sensitive analog control function.